

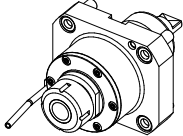
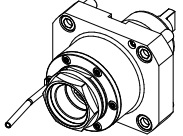
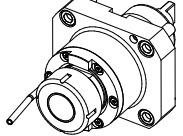
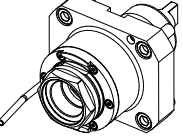
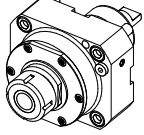
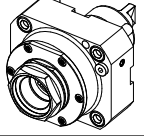
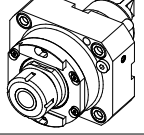
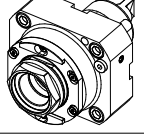
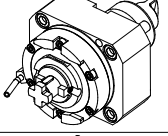
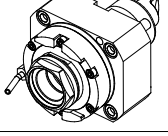
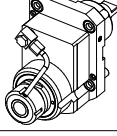
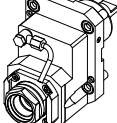
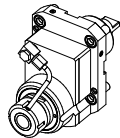
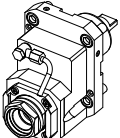
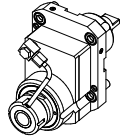
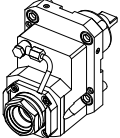
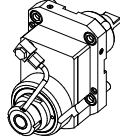
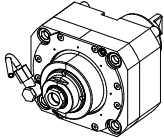
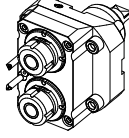
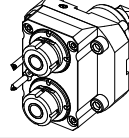
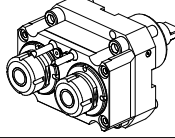
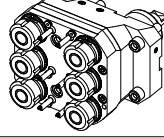
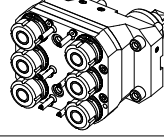
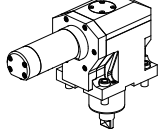
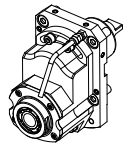
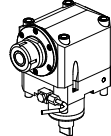
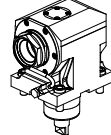
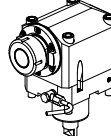
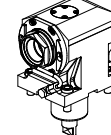
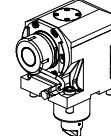
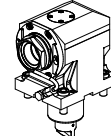
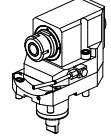
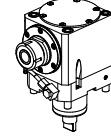
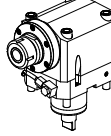
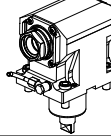
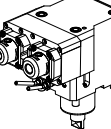
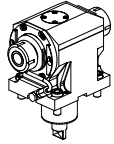
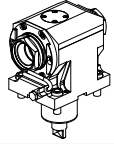
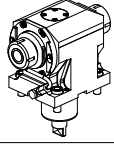
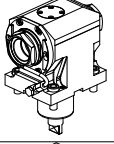
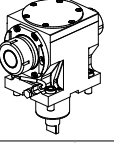
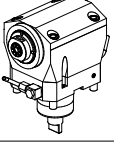
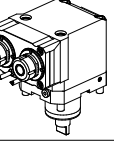
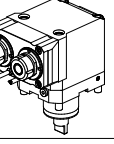
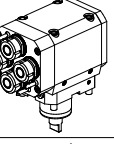
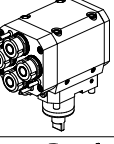
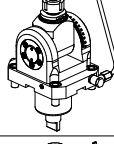
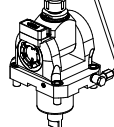
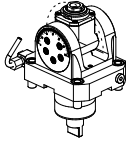
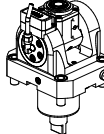
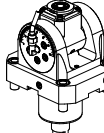
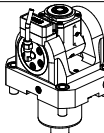

		PAGINA Page Seite
<p>MODULO MOTORIZZATO RADIALE Radial driven tool Radial angetriebenes Werkzeug</p>		MNL010.1.00
<p>MODULO MOTORIZZATO RADIALE MTSK Radial MTSK driven tool Radial MTSK angetriebenes Werkzeug</p>		MNL010.1.00.K
<p>MODULO MOTORIZZATO RADIALE 10000 RPM Radial driven tool 10000 rpm Radial angetriebenes Werkzeug 10000 rpm</p>		MNL010.1.01
<p>MODULO MOTORIZZATO RADIALE MTSK 10000 RPM Radial MTSK driven tool 10000 rpm Radial MTSK angetriebenes Werkzeug 10000 rpm</p>		MNL010.1.01.K
<p>MODULO MOTORIZZATO RADIALE ALTA PRESSIONE Radial driven tool high pressure Radial angetriebenes Werkzeug hochdruck</p>		MNL010.1.20
<p>MODULO MOTORIZZATO RADIALE MTSK ALTA PRESSIONE Radial MTSK driven tool high pressure Radial MTSK angetriebenes Werkzeug hochdruck</p>		MNL010.1.20.K
<p>MODULO MOTORIZZATO RADIALE 10000 RPM Radial driven tool 10000 rpm Radial angetriebenes Werkzeug 10000 rpm</p>		MNL010.1.21
<p>MODULO MOTORIZZATO RADIALE MTSK 10000 RPM Radial MTSK driven tool 10000 rpm Radial MTSK angetriebenes Werkzeug 10000 rpm</p>		MNL010.1.21.K
<p>MODULO MOTORIZZATO RADIALE MAGGIORATO Radial reinforced driven tool Radial angetriebenes Werkzeug vergrößert</p>		MNL020.1.00
<p>MODULO MOTORIZZATO RADIALE MAGGIORATO MTSK Radial MTSK reinforced driven tool Radial MTSK angetriebenes Werkzeug vergrößert</p>		MNL020.1.00.K
<p>MODULO MOTORIZZATO RADIALE RIDOTTO I=2:1 DISASSATO IN Z 45mm Radial geared-down I=2:1 driven tool re-directed in Z by 45mm Radial angetriebenes Werkzeug untersetzt I=2:1 achsversetzt in Z um 45mm</p>		MNL030.1.20
<p>MODULO MOTORIZZATO RADIALE MTSK RIDOTTO I=2:1 DISASSATO IN Z 45mm Radial MTSK geared-down I=2:1 driven tool re-directed in Z by 45mm Radial MTSK angetriebenes Werkzeug untersetzt I=2:1 achsversetzt in Z um 45mm</p>		MNL030.1.20.K

		PAGINA Page Seite
<p>MODULO MOTORIZZATO RADIALE DISASSATO IN Z 45mm Radial driven tool re-directed in Z by 45mm Radial angetriebenes Werkzeug achsversetzt in Z um 45mm</p>		MNL033.1.10
<p>MODULO MOTORIZZATO RADIALE MTSK DISASSATO IN Z 45mm Radial MTSK driven tool re-directed in Z by 45mm Radial MTSK angetriebenes Werkzeug achsversetzt in Z um 45mm</p>		MNL033.1.10.K
<p>MODULO MOTORIZZATO RADIALE DISASSATO IN Z 45mm 10000 RPM Radial driven tool re-directed in Z by 45mm 10000 rpm Radial angetriebenes Werkzeug achsversetzt in Z um 45mm 10000 rpm</p>		MNL033.1.11
<p>MODULO MOTORIZZATO RADIALE MTSK DISASSATO IN Z 45mm 10000 RPM Radial MTSK driven tool re-directed in Z by 45mm 10000 rpm Radial MTSK angetriebenes Werkzeug achsversetzt in Z um 45mm 10000 rpm</p>		MNL033.1.11.K
<p>MODULO MOTOR. RADIALE MOLTIPLICATO I=1:2 DISASSATO IN Z 45mm Radial geared-up I=1:2 driven tool re-directed in Z by 45mm Radial angetriebenes Werkzeug uebersetzt I=1:2 achsversetzt in Z um 45mm</p>		MNL033.1.30
<p>MODULO MOTORIZZATO RADIALE MOLTIPLICATO I=1:5 Radial geared-up I=1:5 driven tool Radial angetriebenes Werkzeug uebersetzt I=1:5</p>		MNL059.1.00
<p>MODULO MOTORIZZATO RADIALE 2 USCITE IN Y Radial single side twin head driven tool in Y Radial angetriebenes Werkzeug 2 Ausgaenge in Y</p>		MNL080.1.00
<p>MODULO MOTORIZZATO RADIALE 2 USCITE IN Y 10000 RPM Radial single side twin head driven tool in Y 10000 rpm Radial angetriebenes Werkzeug 2 Ausgaenge in Y 10000 rpm</p>		MNL080.1.01
<p>MODULO MOTORIZZATO RADIALE 2 USCITE IN Z Radial single side twin head driven tool in Z Radial angetriebenes Werkzeug 2 Ausgaenge in Z</p>		MNL090.1.00
<p>MODULO MOTORIZZATO RADIALE 6 USCITE Radial 6 head driven tool Radial angetriebenes Werkzeug 6 Ausgaenge</p>		MNL110.1.00
<p>MODULO MOTORIZZATO RADIALE 6 USCITE 10000 RPM Radial 6 head driven tool 10000 rpm Radial angetriebenes Werkzeug 6 Ausgaenge 10000 rpm</p>		MNL110.1.01
<p>MODULO MOTORIZZATO RADIALE ROVESCiato DISASSATO IN Z Radial inverted driven tool re-directed in Z Radial angetriebenes Werkzeug ungekehrt achsversetzt in Z</p>		MNL120.1.30

		PAGINA Page Seite
<p>MODULO MOTORIZZATO RADIALE DISASSATO 50mm ORIENTABILE $\pm 25^\circ$ Radial $\pm 25^\circ$ adjustable angle driven tool re-directed by 50mm Radial angetriebenes Werkzeug schwenkbar $\pm 25^\circ$ achsversetzt um 50mm</p>		MNL135.1.00
<p>MODULO MOTORIZZATO ASSIALE Axial driven tool Axial angetriebenes Werkzeug</p>		MNL150.1.10
<p>MODULO MOTORIZZATO ASSIALE MTSK Axial MTSK driven tool Axial MTSK angetriebenes Werkzeug</p>		MNL150.1.10.K
<p>MODULO MOTORIZZATO ASSIALE 10000 RPM Axial driven tool 10000 rpm Axial angetriebenes Werkzeug 10000 rpm</p>		MNL150.1.11
<p>MODULO MOTORIZZATO ASSIALE MTSK 10000 RPM Axial MTSK driven tool 10000 rpm Axial MTSK angetriebenes Werkzeug 10000 rpm</p>		MNL150.1.11.K
<p>MODULO MOTORIZZATO ASSIALE Axial driven tool Axial angetriebenes Werkzeug</p>		MNL170.1.10
<p>MODULO MOTORIZZATO ASSIALE MTSK Axial MTSK driven tool Axial MTSK angetriebenes Werkzeug</p>		MNL170.1.10.K
<p>MODULO MOTORIZZATO ASSIALE ARRETRATO Axial rear-set driven tool Axial angetriebenes Werkzeug zurueckversetzt</p>		MNL180.1.10
<p>MODULO MOTORIZZATO ASSIALE RIDOTTO I=2:1 Axial geared-down I=2:1 driven tool Axial angetriebenes Werkzeug untersetzt I=2:1</p>		MNL190.1.10
<p>MODULO MOTORIZZATO ASSIALE MOLTIPLICATO I=1:2 Axial geared-up I=1:2 driven tool Axial angetriebenes Werkzeug uebersetzt I=1:2</p>		MNL200.1.10
<p>MODULO MOTORIZZATO ASSIALE MTSK PER POLIGONATURA INTERNA H=90mm Axial MTSK driven tool for internal polygon-making H=90mm Axial MTSK angetriebenes Werkzeug fuer interne Facettierung H=90mm</p>		MNL231.1.10.K
<p>MODULO MOTOR. ASSIALE 2 USCITE IN Y PER POLIGON. INTERNA H=90mm Axial Single side twin head driven tool in Y for internal polygon-making H=90mm Axial angetriebenes Werkzeug 2 Ausgaenge in Y fuer interne Facettierung H=90mm</p>		MNL233.1.10

		PAGINA Page Seite
<p>MODULO MOTORIZZATO ASSIALE BISPORGENTE</p> <p>Axial opposite face twin driven tool</p> <p>Axial angetriebenes Werkzeug halb vorspringend</p>		MNL240.1.10
<p>MODULO MOTORIZZATO ASSIALE BISPORGENTE MTSK</p> <p>Axial MTSK opposite face twin driven tool</p> <p>Axial MTSK angetriebenes Werkzeug halb vorspringend</p>		MNL240.1.10.K
<p>MODULO MOTORIZZATO ASSIALE BISPORGENTE 10000 RPM</p> <p>Axial opposite face twin driven tool 10000 rpm</p> <p>Axial angetriebenes Werkzeug halb vorspringend 10000 rpm</p>		MNL240.1.11
<p>MODULO MOTORIZZATO ASSIALE BISPORGENTE MTSK 10000 RPM</p> <p>Axial MTSK opposite face twin driven tool 10000 rpm</p> <p>Axial MTSK angetriebenes Werkzeug halb vorspringend 10000 rpm</p>		MNL240.1.11.K
<p>MODULO MOTORIZZATO ASSIALE BISPORGENTE RIDOTTO I=2:1</p> <p>Axial geared-down I=2:1 opposite face twin driven tool</p> <p>Axial angetriebenes Werkzeug halb vorspringend untersetzt I=2:1</p>		MNL247.1.10
<p>MODULO MOTORIZZATO ASSIALE BISPORGENTE MOLTIPLICATO I=1:2</p> <p>Axial geared-up I=1:2 opposite face twin driven tool</p> <p>Axial angetriebenes Werkzeug halb vorspringend uebersetzt I=1:2</p>		MNL250.1.10
<p>MODULO MOTORIZZATO ASSIALE 2 USCITE IN Y</p> <p>Axial single side twin head driven tool in Y</p> <p>Axial angetriebenes Werkzeug 2 Ausgaenge in Y</p>		MNL260.1.10
<p>MODULO MOTORIZZATO ASSIALE 2 USCITE IN Y 10000 RPM</p> <p>Axial Single side twin head driven tool in Y 10000 rpm</p> <p>Axial angetriebenes Werkzeug 2 Ausgaenge in Y 10000 rpm</p>		MNL260.1.11
<p>MODULO MOTORIZZATO ASSIALE 4/8 USCITE</p> <p>Axial multiple 4/8 outlet driven tool</p> <p>Axial angetriebenes Mehrspindel-Werkzeug 4/8 Ausgaenge</p>		MNL270.1.00
<p>MODULO MOTORIZZATO ASSIALE 4/8 USCITE 10000 RPM</p> <p>Axial multiple 4/8 outlet driven tool 10000 rpm</p> <p>Axial angetriebenes Mehrspindel-Werkzeug 4/8 Ausgaenge 10000 rpm</p>		MNL270.1.01
<p>MODULO MOTORIZZATO ORIENTABILE $\pm 90^\circ$</p> <p>$\pm 90^\circ$ adjustable angle driven tool</p> <p>Angetriebenes Werkzeug schwenkbar $\pm 90^\circ$</p>		MNL333.1.00
<p>MODULO MOTORIZZATO ORIENTABILE $\pm 90^\circ$ CON NONIO DIGITALE</p> <p>$\pm 90^\circ$ adjustable angle driven tool with digital display</p> <p>Angetriebenes Werkzeug schwenkbar $\pm 90^\circ$ mit digital display</p>		MNL333.1.01

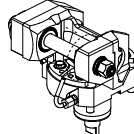
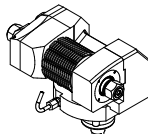
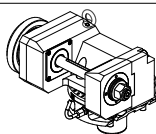
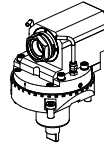
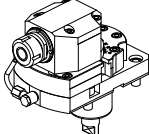
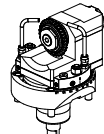
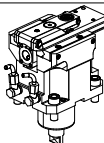
		PAGINA Page Seite
<p>MODULO MOTORIZZATO ORIENTABILE $\pm 90^\circ$ $\pm 90^\circ$ adjustable angle driven tool Angetriebenes Werkzeug schwenkbar $\pm 90^\circ$</p>		MNL335.1.00
<p>MODULO MOTORIZZATO ORIENTABILE $\pm 90^\circ$ CON NONIO DIGITALE $\pm 90^\circ$ adjustable angle driven tool with digital display Angetriebenes Werkzeug schwenkbar $\pm 90^\circ$ mit digital display</p>		MNL335.1.01
<p>MODULO MOTORIZZATO ORIENTABILE $\pm 90^\circ$ MOLTIPLICATO I=1:2 $\pm 90^\circ$ adjustable angle driven tool geared-up I=1:2 Angetriebenes Werkzeug schwenkbar $\pm 90^\circ$ uebersetzt I=1:2</p>		MNL336.1.00
<p>MOD. MOTOR. ORIENTABILE $\pm 90^\circ$ MOLTIPL. I=1:2 CON NONIO DIGITALE $\pm 90^\circ$ adjustable angle driven tool geared-up I=1:2 with digital display Angetriebenes Werkzeug schwenkbar $\pm 90^\circ$ uebersetzt I=1:2 mit digital display</p>		MNL336.1.01
<p>MODULO MOTORIZZATO ORIENTABILE $\pm 90^\circ$ $\pm 90^\circ$ adjustable angle driven tool Angetriebenes Werkzeug schwenkbar $\pm 90^\circ$</p>		MNL339.1.00
<p>MODULO MOTORIZZATO PORTACREATORE Driven gear hobber Angetriebenes Zahnradwaelzfraes-Werkzeug</p>		MNL340.1.00
<p>MODULO MOTORIZZATO PORTACREATORE MAGGIORATO Reinforced gear hobber Angetriebenes Zahnradwaelzfraes-Werkzeug vergroessert</p>		MNL340.1.60
<p>MODULO MOTORIZZATO PORTACREATORE (TAGLIA GRANDE) Driven gear hobber (big size) Angetriebenes Zahnradwaelzfraes-Werkzeug (grosse version)</p>		MNL340.1.80
<p>MODULO MOTORIZZATO ASSIALE MTSK PER POWER SKIVING H=106mm Axial MTSK driven tool for Power Skiving H=106mm Axial MTSK angetriebenes Werkzeug fuer Power Skiving H=106mm</p>		MNL350.1.00.K
<p>MODULO MOTORIZZATO INCLINEVOLE $\pm 45^\circ$ IN Y $\pm 45^\circ$ Y axis adjustable angle driven tool Angetriebenes Werkzeug kippbar $\pm 45^\circ$ in Y</p>		MNL358.1.00
<p>MODULO MOTORIZZATO PER VITI SENZA FINE Driven tool for worm screws Angetriebenes werkzeug fuer schrauben ohne ende</p>		MNL359.1.00
<p>MODULO MOTORIZZATO STOZZATORE CORSA 50mm H=94mm Slotting driven tool 50mm stroke H=94mm Keilnutenstossmaschine 50mm Hub H=94mm</p>		MNL360.1.00

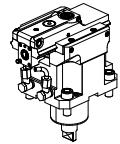
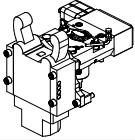
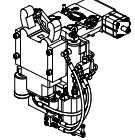
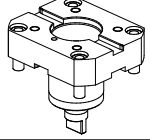
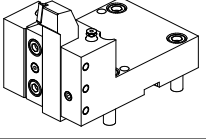
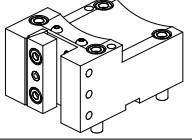
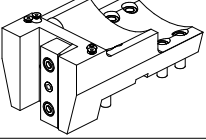
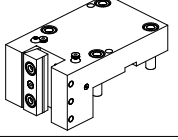
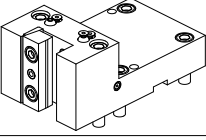
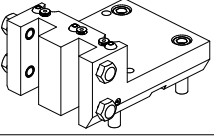
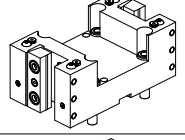
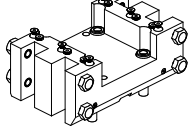
		PAGINA Page Seite
<p>MODULO MOTORIZZATO STOZZATORE CORSA 25mm H=94mm Slotting driven tool 25mm stroke H=94mm Keilnutenstossmaschine 25mm Hub H=94mm</p>		MNL360.1.01
<p>MODULO MOTORIZZATO PER LUNETTA (TAGLIA 2) Steady rest driven tool (Size 2) Angetriebenes Werkzeug fuer Luenette (Grossesse 2)</p>		MNL361.1.10
<p>MODULO MOTORIZZATO PER LUNETTA RETRATTILE (TAGLIA 2) Driven toolholder for sliding steady rest (Size 2) Luenettenwerkzeug zurueck versetzte Version (Grossesse 2)</p>		MNL363.1.00
<p>INTERFACCIA PER MODULI BIGLIA Biglia tooling adapter cartridge Adapter-Patrone fuer Biglia Werkzeuge</p>		MNL380.1.00
<p>PORTAUTENSILE RADIALE SINGOLO QD=25mm / QD=1" / QD=20mm / QD=3/4" Radial single static tool QD=25mm / QD=1" / QD=20mm / QD=3/4" Radial Single-Werkzeughalter QD=25mm / QD=1" / QD=20mm / QD=3/4"</p>		MNL423.1.00
<p>PORTAUTENSILE RADIALE SINGOLO QD=25mm / QD=20mm Radial single static tool QD=25mm / QD=20mm Radial Single-Werkzeughalter QD=25mm / QD=20mm</p>		MNL424.1.00
<p>PORTAUTENSILE RADIALE SINGOLO QD=32mm / QD=1 1/4" Radial single static tool QD=32mm / QD=1 1/4" Radial Single-Werkzeughalter QD=32mm / QD=1 1/4"</p>		MNL426.1.00
<p>PORTAUT. RADIALE SINGOLO ARRETR. QD=25mm / QD=1" / QD=20mm / QD=3/4" Radial rear-set single static tool QD=25mm / QD=1" / QD=20mm / QD=3/4" Radial Single-Werkzeughalter zurueckver. QD=25mm / QD=1" / QD=20mm / QD=3/4"</p>		MNL433.1.00
<p>PORTAUTENSILE RADIALE SINGOLO PER CONTROMANDRINO QD=25mm Radial single static tool for subspindle QD=25mm Radial Single-Werkzeughalter fuer Gegenspindel QD=25mm</p>		MNL436.1.00
<p>PORTAUT. RADIALE SOVRAPPOSTO QD=25mm / QD=1" / QD=20mm / QD=3/4" Radial single side twin static tool QD=25mm / QD=1" / QD=20mm / QD=3/4" Radial Werkzeughalter ueberlagert QD=25mm / QD=1" / QD=20mm / QD=3/4"</p>		MNL442.1.00
<p>PORTAUTENSILE RADIALE DOPPIO QD=25mm / QD=1" / QD=20mm / QD=3/4" Radial double static tool QD=25mm / QD=1" / QD=20mm / QD=3/4" Radial Doppel-Werkzeughalter QD=25mm / QD=1" / QD=20mm / QD=3/4"</p>		MNL453.1.00
<p>PORTAUT. RADIALE DOPPIO SOVRAPP. QD=25mm / QD=1" / QD=20mm / QD=3/4" Radial double side twin static tool QD=25mm / QD=1" / QD=20mm / QD=3/4" Radial Doppel-Werkzeughalter ueberlagert QD=25mm / QD=1" / QD=20mm / QD=3/4"</p>		MNL463.1.00

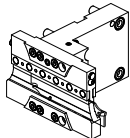
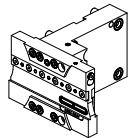
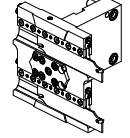
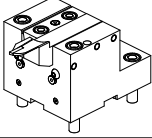
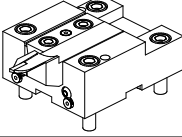
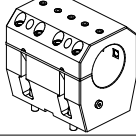
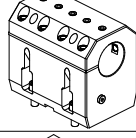
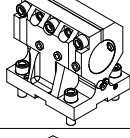
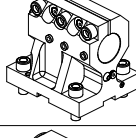
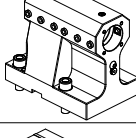
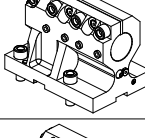
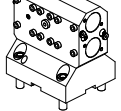
		PAGINA Page Seite
<p>PORTAUTENSILE PER LAMA DOPPIO Radial double blade holder Radial Doppel-Abstechhalter</p>		MNL520.1.00
<p>PORTAUTENSILE PER LAMA DOPPIO CON LUBRIFICAZIONE INTERNA Radial double blade holder with internal coolant Radial Doppel-Abstechhalter mit Innenkuehlung</p>		MNL520.1.04
<p>PORTAUTENSILE PER LAMA DOPPIO E SOVRAPPOSTO Radial double twin-side blade holder Radial Doppel-Abstechhalter ueberlagert</p>		MNL525.1.00
<p>PORTAUTENSILE ASSIALE SINGOLO QD=25mm / QD=1" / QD=20mm / QD=3/4" Axial single static tool QD=25mm / QD=1" / QD=20mm / QD=3/4" Axial Single-Werkzeughalter QD=25mm / QD=1" / QD=20mm / QD=3/4"</p>		MNL552.1.00
<p>PORTAUTENSILE ASSIALE RIBASSATO SINGOLO QD=25mm / QD=20mm Axial single lower height static tool QD=25mm / QD=20mm Axial Single-Werkzeughalter abgeflacht QD=25mm / QD=20mm</p>		MNL562.1.00
<p>PORTAUTENSILE ASSIALE PER BARENO Ø80mm H=110mm Axial single boring bar holder Ø80mm H=110mm Axial Bohrhalter Ø80mm H=110mm</p>		MNL580.1.20
<p>PORTAUTENSILE ASSIALE PER BARENO Ø60mm H=110mm Axial single boring bar holder Ø60mm H=110mm Axial Bohrhalter Ø60mm H=110mm</p>		MNL590.1.20
<p>PORTAUTENSILE ASSIALE PER BARENO Ø50mm / Ø2" H=80mm Axial single boring bar holder Ø50mm / Ø2" H=80mm Axial Bohrhalter Ø50mm / Ø2" H=80mm</p>		MNL610.1.20
<p>PORTAUTENSILE ASSIALE PER BARENO Ø40mm / Ø1 1/2" H=80mm Axial single boring bar holder Ø40mm / Ø1 1/2" H=80mm Axial Bohrhalter Ø40mm / Ø1 1/2" H=80mm</p>		MNL630.1.20
<p>PORTAUTENSILE ASSIALE PROLUNGATO PER BARENO Ø40mm H=115mm Axial single extended boring bar holder Ø40mm H=115mm Axial Bohrhalter verlaengert Ø40mm H=115mm</p>		MNL760.1.10
<p>PORTAUTENSILE ASSIALE PROLUNGATO PER BARENO Ø40mm H=80mm Axial single extended boring bar holder Ø40mm H=80mm Axial Bohrhalter verlaengert Ø40mm H=80mm</p>		MNL760.1.20
<p>PORTAUTENSILE ASSIALE PER BARENO 2+2 POSIZIONI Ø32mm / Ø1 1/4" Axial 2+2 position boring bar holder Ø32mm / Ø1 1/4" Axial Bohrhalter 2+2 Positionen Ø32mm / Ø1 1/4"</p>		MNL872.1.00

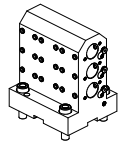
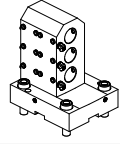
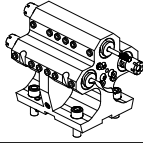
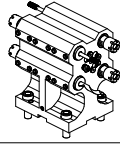
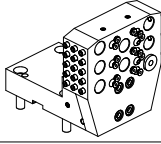
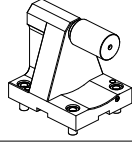
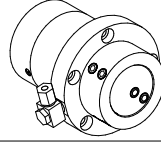
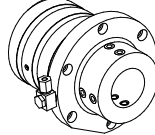
		PAGINA Page Seite
<p>PORTAUTENSILE ASSIALE PER BARENO 3+3 POSIZIONI $\varnothing 25\text{mm} / \varnothing 1''$ Axial 3+3 position boring bar holder $\varnothing 25\text{mm} / \varnothing 1''$ Axial Bohrhalter 3+3 Positionen $\varnothing 25\text{mm} / \varnothing 1''$</p>		MNL894.1.00
<p>PORTAUTENSILE ASSIALE ARRETRATO PER BARENO 3 POSIZIONI $\varnothing 25\text{mm} / \varnothing 1''$ Axial 3 position rear set boring bar holder $\varnothing 25\text{mm} / \varnothing 1''$ Axial Bohrhalter 3 Positionen zurueckversetzt $\varnothing 25\text{mm} / \varnothing 1''$</p>		MNL904.1.00
<p>PORTAUTENSILE ASSIALE PER BARENO 3+3 POSIZIONI $\varnothing 32\text{mm} / \varnothing 1\ 1/4''$ Axial 3+3 position boring bar holder $\varnothing 32\text{mm} / \varnothing 1\ 1/4''$ Axial Bohrhalter 3+3 Positionen $\varnothing 32\text{mm} / \varnothing 1\ 1/4''$</p>		MNL912.1.00
<p>PORTAUTENSILE ASSIALE PER BARENO 4+4 POSIZIONI $\varnothing 25\text{mm} / \varnothing 1''$ Axial 4+4 position boring bar holder $\varnothing 25\text{mm} / \varnothing 1''$ Axial Bohrhalter 4+4 Positionen $\varnothing 25\text{mm} / \varnothing 1''$</p>		MNL922.1.00
<p>PORTAUTENSILE ASSIALE PER BARENO 8 POSIZIONI $\varnothing 20\text{mm} / \varnothing 3/4''$ Axial 8 position boring bar holder $\varnothing 20\text{mm} / \varnothing 3/4''$ Axial Bohrhalter 8 Positionen $\varnothing 20\text{mm} / \varnothing 3/4''$</p>		MNL933.1.00
<p>CONTROPUNTA PER CONTROMANDRINO Tailstock for subspindle Gegenspintz fuer Gegenspindel</p>		MNL950.1.00
<p>ADATTATORE CONTROPUNTA (DISTANZA PUNTE 700mm) Tailstock adapter (700mm drill head distance) Gegenspitz-Adapter (Spitzabstand 700mm)</p>		MNL955.1.00
<p>ADATTATORE CONTROPUNTA (DISTANZA PUNTE 1250mm) Tailstock adapter (1250mm drill head distance) Gegenspitz-Adapter (Spitzabstand 1250mm)</p>		MNL960.1.00

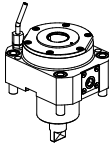
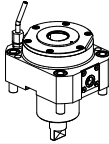
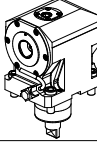
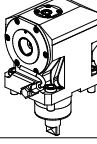
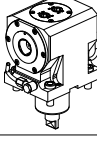
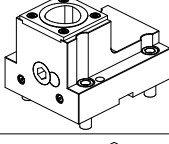
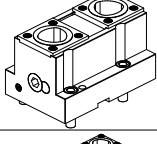
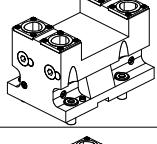
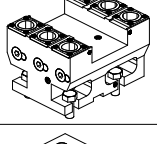
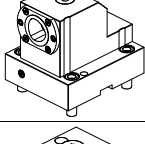
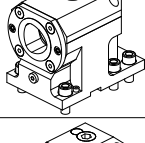
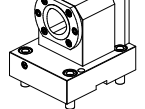
		PAGINA Page Seite
<p>MODULO MOTORIZZATO RADIALE MT CAPTO Radial driven tool MT CAPTO Radial angetriebenes Werkzeug MT CAPTO</p>		MNL010.A.40
<p>MODULO MOTORIZZATO RADIALE 10000 RPM MT CAPTO Radial driven tool 10000 rpm MT CAPTO Radial angetriebenes Werkzeug 10000 rpm MT CAPTO</p>		MNL010.A.41
<p>MODULO MOTORIZZATO ASSIALE MT CAPTO Axial driven tool MT CAPTO Axial angetriebenes Werkzeug MT CAPTO</p>		MNL150.A.40
<p>MODULO MOTORIZZATO ASSIALE 10000 RPM MT CAPTO Axial driven tool 10000 rpm MT CAPTO Axial angetriebenes Werkzeug 10000 rpm MT CAPTO</p>		MNL150.A.41
<p>MODULO MOTORIZZATO ASSIALE BISPORGENTE 10000 RPM MT CAPTO Axial opposite face twin driven tool 10000 rpm MT CAPTO Axial angetriebenes Werkzeug halb vorspringend 10000 rpm mit MT CAPTO</p>		MNL240.A.41
<p>PORTAUTENSILE RADIALE SINGOLO MT CAPTO Radial single static tool MT CAPTO Radial Single-Werkzeughalter MT CAPTO</p>		MNL420.A.40
<p>PORTAUTENSILE RADIALE DOPPIO MT CAPTO Radial double static tool MT CAPTO Radial doppel-Werkzeughalter MT CAPTO</p>		MNL450.A.40
<p>PORTAUTENSILE RADIALE DOPPIO SOVRAPP. 2+2 POS. MT CAPTO Radial double 2+2 upright position static tool MT CAPTO Radial Doppel-Werkzeughalter 2+2 Positionen ueberlagert MT CAPTO</p>		MNL460.A.30
<p>PORTAUTENSILE RADIALE DOPPIO SOVRAPP. 3+3 POS. MT CAPTO Radial double 3+3 upright position static tool MT CAPTO Radial Doppel-Werkzeughalter 3+3 Positionen ueberlagert MT CAPTO</p>		MNL465.A.30
<p>PORTAUTENSILE ASSIALE SINGOLO MT CAPTO Axial single static tool MT CAPTO Axial Single-Werkzeughalter MT CAPTO</p>		MNL550.A.40
<p>PORTAUTENSILE ASSIALE SINGOLO MT CAPTO Axial single static tool MT CAPTO Axial Single-Werkzeughalter MT CAPTO</p>		MNL552.A.60
<p>PORTAUTENSILE ASSIALE SINGOLO ARRETRATO MT CAPTO Axial rear set boring single static tool MT CAPTO Axial Single-Werkzeughalter zurueckversetzt MT CAPTO</p>		MNL555.A.40

		PAGINA Page Seite
PORTAUTENSILE ASSIALE BISPORGENTE MT CAPTO Axial opposite face twin static tool MT CAPTO Axial Halter halb vorspringend mit MT CAPTO		MNL570.A.40

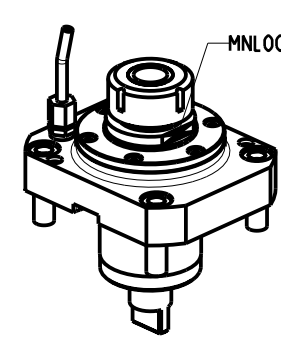
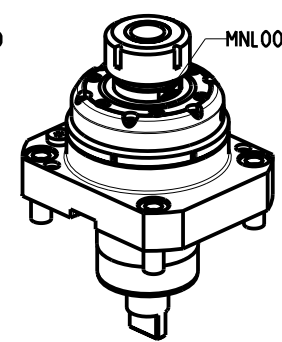
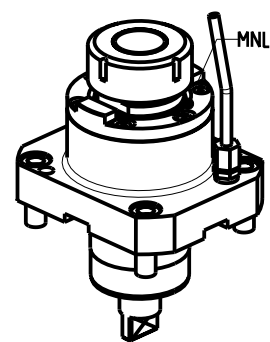
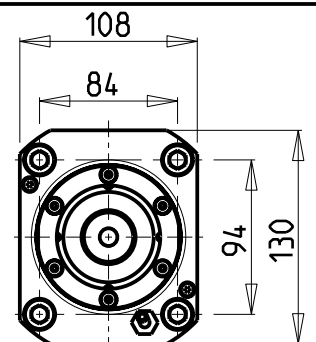
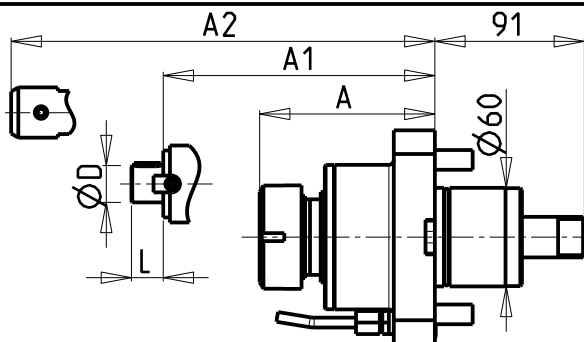

- Chiave inclusa
- Key included
- Schluessel inbegriffen

Cod. MT	Cod. MORI-SEIKI	Mandrino Spindle Spindel	I	RPM	Coppia Max Max Torque Max Drehmoment	Lubrificazione int. Coolant through Innenkuehlung	Lubrificazione est. Ext. coolant Aussenkuehlung	A	A1	A2	D	L	CHIAVI NON INCLUDE Keys not included Schluessel nicht einbegriffen	
MNL0020532	T32206	ER32	1:1	6000	100Nm	-	X	104.16	-	-	-	-	OKU0650004	CHSTER32
MNL0020140	T32213	ER40	1:1	6000	100Nm	-	X	106.66	-	-	-	-	OKU0650004	CHSTER40
MNL1230232	-	ER32	1:1	6000	100Nm	P=70bar	X	104.66	-	-	-	-	OKU0650004	CHSTER32
MNL1230240	-	ER40	1:1	6000	100Nm	P=70bar	X	107.66	-	-	-	-	OKU0650004	CHSTER40
MNL0020632	-	ER32	1:1	6000	100Nm	-	X	144.16	-	-	-	-	OKU0650004	CHSTER32
MNL0021632	-	ER32	1:1	6000	100Nm	P=30bar	X	144.16	-	-	-	-	OKU0650004	CHSTER32
MNL0020732	-	ER32	1:1	6000	100Nm	P=30bar	X	107.66	-	-	-	-	CHUB36	CHSTER32
MNL0021617	-	Ø16x17	1:1	6000	100Nm	-	X	-	116	-	16	17	OKU0650004	CH_VTCROCE_M08
MNL0020116	-	Ø16x17	1:1	6000	100Nm	P=30bar	X	-	116	-	16	17	OKU0650004	CH_VTCROCE_M08
MNL0022219	-	Ø22x19	1:1	6000	100Nm	-	X	-	106	-	22	19	OKU0650004	CH_VTCROCE_M10
MNL0020122	-	Ø22x19	1:1	6000	100Nm	P=30bar	X	-	106	-	22	19	OKU0650004	CH_VTCROCE_M10
MNL0022721	-	Ø27x21	1:1	6000	100Nm	-	X	-	81.5	-	27	21	OKU0650004	CH_VTCROCE_M12
MNL0022519	-	Ø1" x19	1:1	6000	100Nm	-	X	-	81.5	-	1"	21	OKU0650004	CH_VTCROCE_M12
MNL0020525	-	Ø1" x19	1:1	6000	100Nm	P=30bar	X	-	84.5	-	1"	21	OKU0650004	CH_VTCROCE_M12
MNL0022132	-	ER32 CORTO-SHORT-KURZ	1:1	6000	100Nm	-	X	75.76	-	-	-	-	CHUB46	CHSTER32
MNL0022140	-	ER40 CORTO-SHORT-KURZ	1:1	6000	100Nm	-	X	89.66	-	-	-	-	CHUB46	CHSTER40
MNL0020120	-	WELDON 20	1:1	6000	100Nm	-	X	-	-	99.5	-	-	-	-
MNL0020125	-	WELDON 25	1:1	6000	100Nm	-	X	-	-	109	-	-	-	-
MNL0020132	-	WELDON 32	1:1	6000	100Nm	-	X	-	-	125.5	-	-	-	-
MNL0020220	-	WELDON 20	1:1	6000	100Nm	P=30bar	X	-	-	99.5	-	-	-	-
MNL0020425	-	WELDON 25	1:1	6000	100Nm	P=30bar	X	-	-	109	-	-	-	-
MNL0020232	-	WELDON 32	1:1	6000	100Nm	P=30bar	X	-	-	125.5	-	-	-	-

NEW
NEW

DMG-MORI
 NL1500/2000/2500/3000 12 STAZIONI - NLX1500/2000/2500/3000 12 STAZIONI - NLX4000 - NZL2000/2500 - NZX2500 (BMT60)
 NT4200/4250/4300/5400 - NTX2000/2500/3000 2ND GEN. 10ST. - CTX2500 (BMT60)

MODULO MOTORIZZATO RADIALE
 Radial driven tool
 Radial angetriebenes Werkzeug

Subject to change without notice.

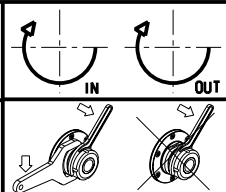

M.T. srl
 Via Casino Albini 480
 Tel. 0541/956034-957884
 Fax 0541/956341
 47842 S. GIOVANNI IN M. (RN)
 e-mail: mtma@mtmarchetti.com
 http://www.mtmarchetti.com



PAGINA MNL010-1-00

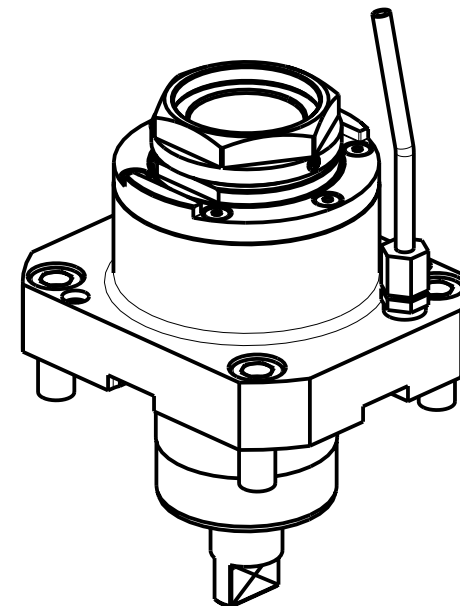
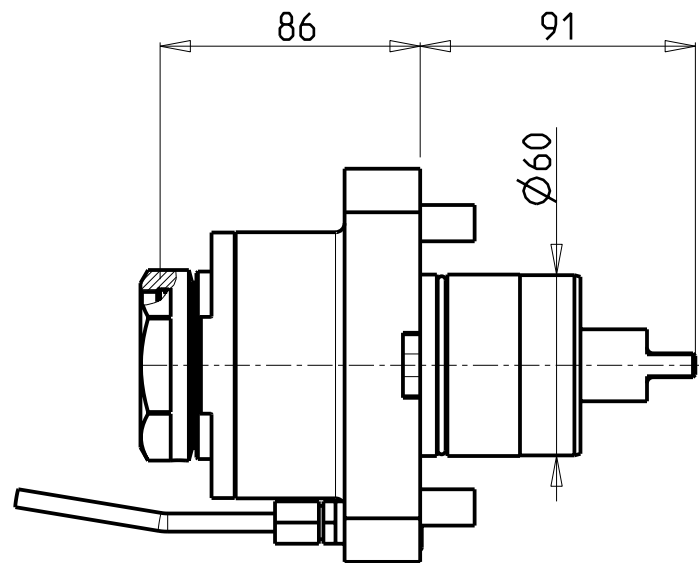
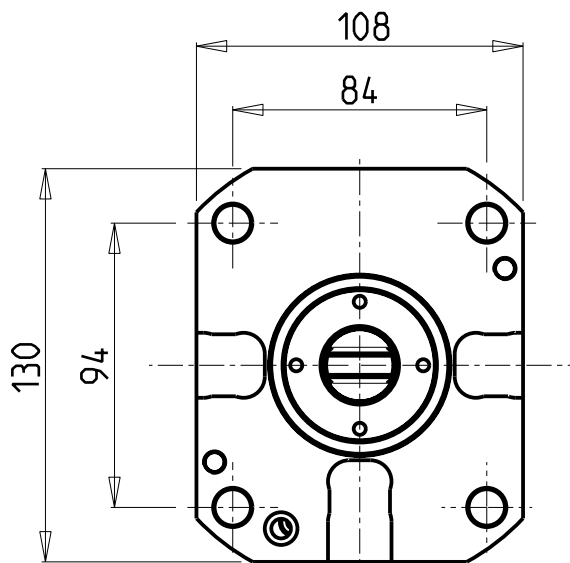

PER PORTAUTENSILI MODULARI MTSK-50 VEDI PAG. TBL300-1-50
 FOR MTSK-50 QUICK CHANGE TOOLHOLDERS CLAMPINGS SEE PAGE TBL300-1-50
 FUER MTSK-50 MODULARE WERKZEUGAUFNAHMEN SIEHE SEITE TBL300-1-50

Cod. MT	Mandrino Spindle Spindel	I	RPM	Coppia Max Max Torque Max Drehmoment	Lubrificazione est. Ext. coolant Aussenkuehlung	CHIAVI NON INCLUSE Keys not included Schlüssel nicht einbegriffen	
MNL0590150	MTSK-50	1:1	6000	100Nm	X	CHUB55	OKU0430007

- Chiave inclusa
- Key included
- Schlüssel inbegriffen

DMG-MORI

NL1500/2000/2500/3000 12 STAZIONI - NLX1500/2000/2500/3000 12 STAZIONI - NLX4000 - NZL2000/2500 - NZX2500 (BMT60)
 NT4200/4250/4300/5400 - NTX2000/2500/3000 2ND GEN. 10ST. - CTX2500 (BMT60)

MODULO MOTORIZZATO RADIALE MTSK

Radial MTSK driven tool

Radial MTSK angetriebenes Werkzeug

Subject to change without notice.

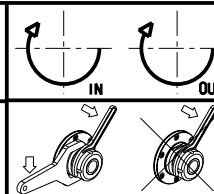

M.T. srl

Via Casino Albini 480
 Tel. 0541/956034-957884
 Fax 0541/956341

47842 S. GIOVANNI IN M. (RN)
 e-mail: mtma@mtmarchetti.com
 http://www.mtmarchetti.com



PAGINA MNL010-1-00-K

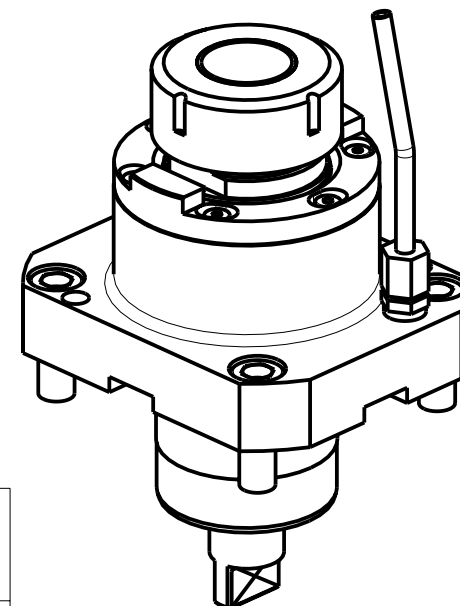
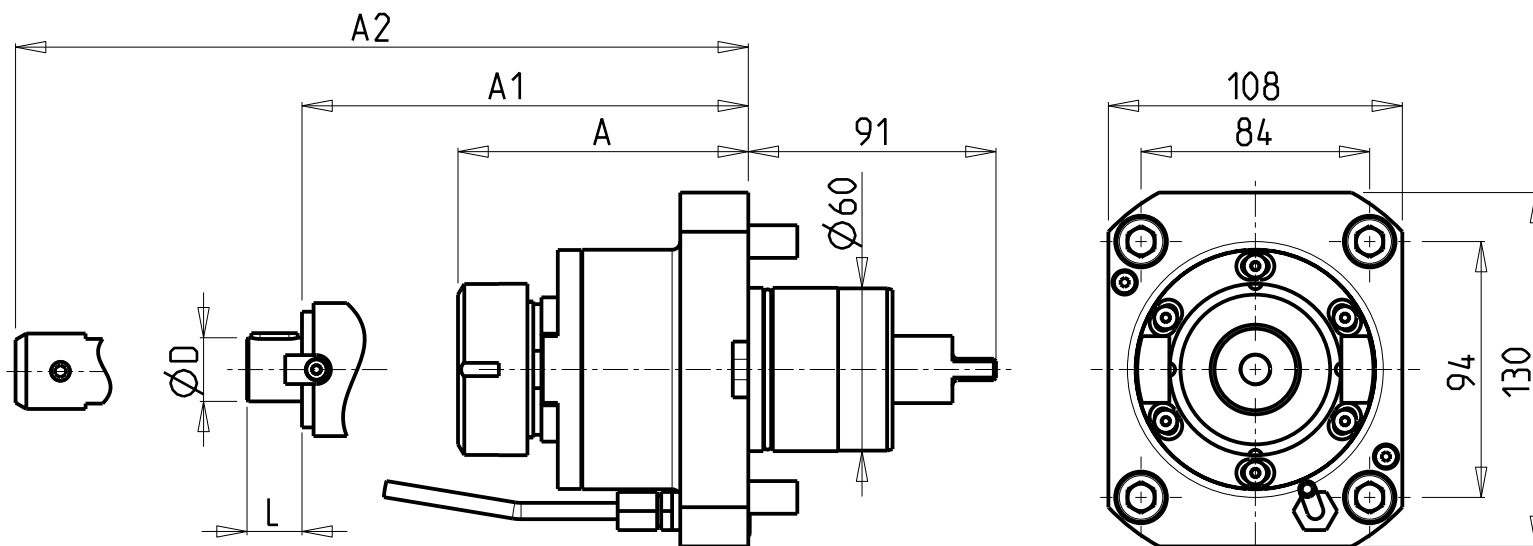

Cod. MT	Mandrino Spindle	I	RPM	Coppia Max Max Torque Max Drehmoment	Lubrificazione est. Exl. coolant Ausseukuehlung	A	A1	A2	D	L	CHIAVI NON INCLUDE Keys not included Schluessel nicht einbegriffen
MNL0760532	ER32	1:1	10000	100Nm	X	104.16	-	-	-	-	OKU0650004 • CHSTER32
MNL0760140	ER40	1:1	10000	100Nm	X	106.66	-	-	-	-	OKU0650004 • CHSTER40
MNL0760632	ER32	1:1	10000	100Nm	X	144.16	-	-	-	-	OKU0650004 • CHSTER32
MNL0761617	Ø16x17	1:1	10000	100Nm	X	-	116	-	16	17	OKU0650004 • CH_VTCROCE_M08 •
MNL0762219	Ø22x19	1:1	10000	100Nm	X	-	106	-	22	19	OKU0650004 • CH_VTCROCE_M10 •
MNL0762721	Ø27x21	1:1	10000	100Nm	X	-	81.5	-	27	21	OKU0650004 • CH_VTCROCE_M12 •
MNL0762519	Ø1"x19	1:1	10000	100Nm	X	-	81.5	-	1"	21	OKU0650004 • CH_VTCROCE_M12 •
MNL0760120	WELDON 20	1:1	10000	100Nm	X	-	-	99.5	-	-	-
MNL0760125	WELDON 25	1:1	10000	100Nm	X	-	-	109	-	-	-
MNL0760132	WELDON 32	1:1	10000	100Nm	X	-	-	125.5	-	-	-

- Chiave inclusa
- Key included
- Schluessel inbegriffen

DMG-MORI

NL1500/2000/2500/3000 12 STAZIONI - NLX1500/2000/2500/3000 12 STAZIONI - NLX4000 - NZL2000/2500 - NZX2500 (BMT60)
 NT4200/4250/4300/5400 - NTX2000/2500/3000 2ND GEN. 10ST. - CTX2500 (BMT60)

MODULO MOTORIZZATO RADIALE 10000 RPM
 Radial driven tool 10000 rpm
 Radial angetriebenes Werkzeug 10000 rpm

Subject to change without notice.

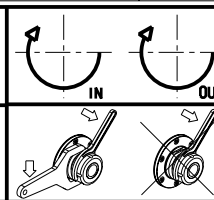

M.T. srl

Via Casino Albini 480
 Tel. 0541/956034-957884
 Fax 0541/956341
 47842 S. GIOVANNI IN M. (RN)
 e-mail: mtma@mtmarchetti.com
 http://www.mtmarchetti.com



PAGINA MNL010-1-01

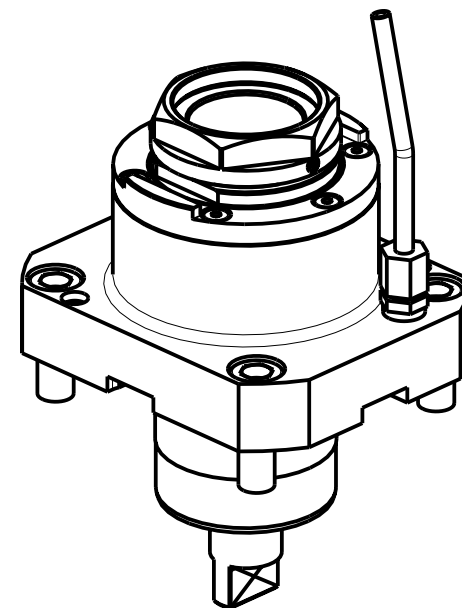
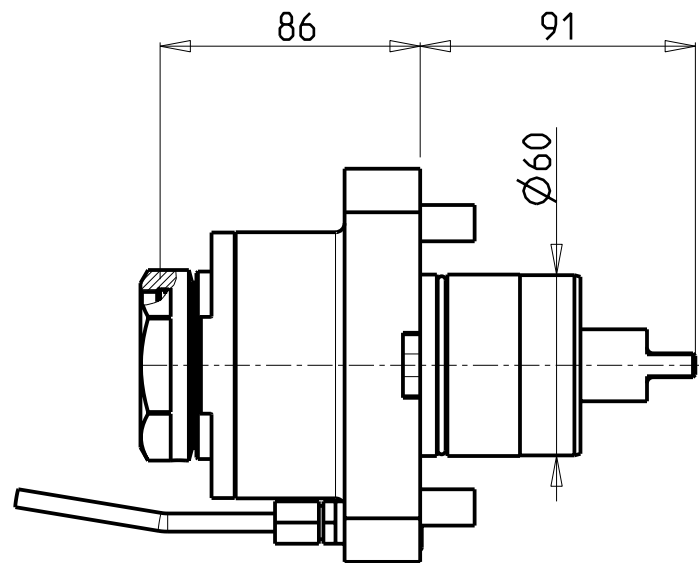
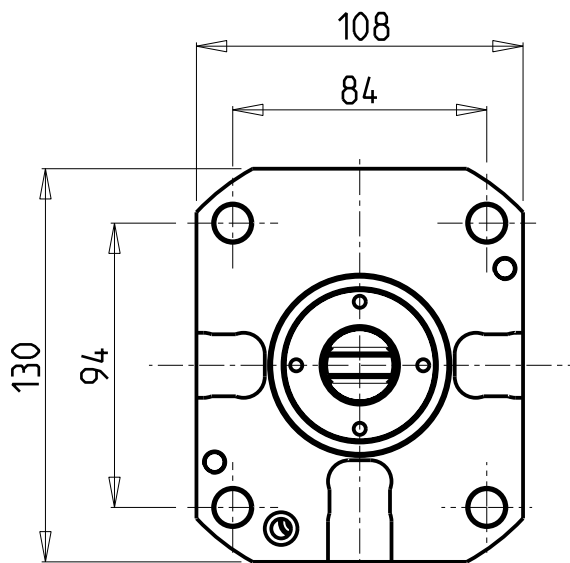

PER PORTAUTENSILI MODULARI MTSK-50 VEDI PAG. TBL300-1-50
 FOR MTSK-50 QUICK CHANGE TOOLHOLDERS CLAMPINGS SEE PAGE TBL300-1-50
 FUER MTSK-50 MODULARE WERKZEUGAUFNAHMEN SIEHE SEITE TBL300-1-50

Cod. MT	Mandrino Spindle Spindel	I	RPM	Coppia Max Max Torque Max Drehmoment	Lubrificazione est. Ext. coolant Aussenkuehlung	CHIAVI NON INCLUSE Keys not included Schlüssel nicht einbegriffen	
						CHUB55	OKU0430007
MNL0790150	MTSK-50	1:1	10000	100Nm	X		

- Chiave inclusa
- Key included
- Schlüssel inbegriffen

DMG-MORI

NL1500/2000/2500/3000 12 STAZIONI - NLX1500/2000/2500/3000 12 STAZIONI - NLX4000 - NZL2000/2500 - NZX2500 (BMT60)
 NT4200/4250/4300/5400 - NTX2000/2500/3000 2ND GEN. 10ST. - CTX2500 (BMT60)

MODULO MOTORIZZATO RADIALE MTSK 10000 RPM

Radial MTSK driven tool 10000 rpm

Radial MTSK angetriebenes Werkzeug 10000 rpm

Subject to change without notice.

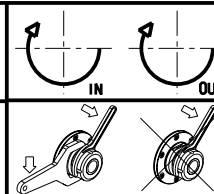

M.T. srl

Via Casino Albini 480
 Tel. 0541/956034-957884
 Fax 0541/956341

47842 S. GIOVANNI IN M. (RN)
 e-mail: mtma@mtmarchetti.com
 http://www.mtmarchetti.com



PAGINA MNL010-1-01-K

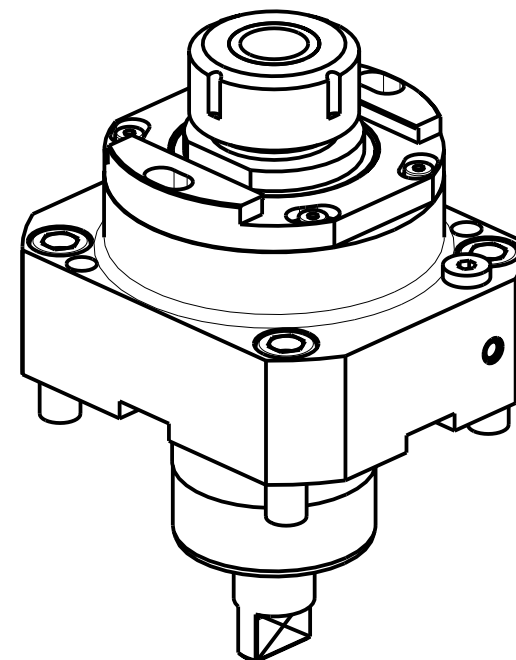
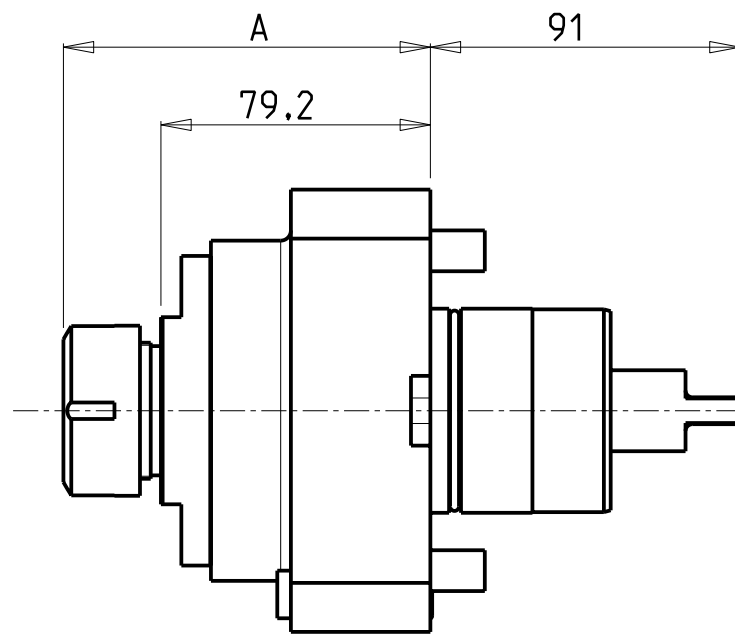
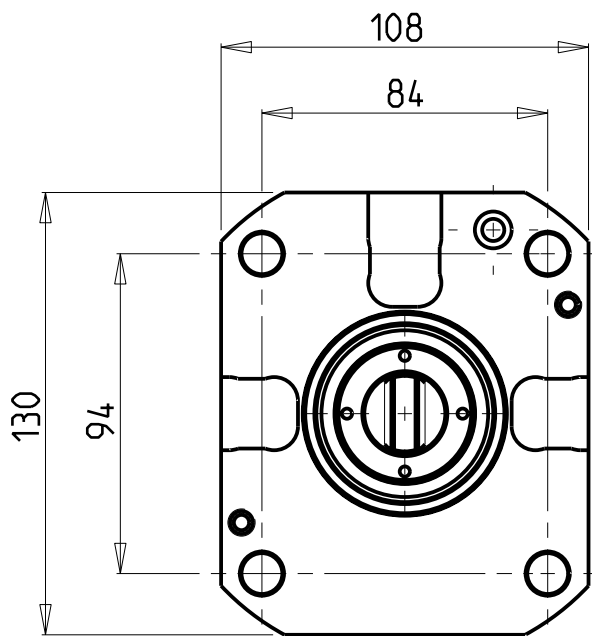

- Chiave inclusa
- Key included
- Schluessel inbegriffen

Cod. MT	Mandrino Spindle Spindel	I	RPM	Coppia Max Max Torque Max Drehmoment	Lubrificazione int. Coolant through Innenkuehlung	Lubrificazione est. Ext. coolant Aussenkuehlung	A	CHIAVI NON INCLUSE Keys not included Schluessel nicht einbegriffen	
								OKU0650004	CHSTER
MNL0570125	ER25	1:1	6000	100Nm	P=80bar	X	104.8	OKU0650004	CHSTER25
MNL0570132	ER32	1:1	6000	100Nm	P=80bar	X	107.8	OKU0650004	CHSTER32

DMG-MORI
 NL1500/2000/2500/3000 12 STAZIONI - NLX1500/2000/2500/3000 12 STAZIONI - NLX4000 - NZL2000/2500 - NZX2500 (BMT60)
 NT4200/4250/4300/5400 - NTX2000/2500/3000 2ND GEN. 10ST. - CTX2500 (BMT60)

MODULO MOTORIZZATO RADIALE ALTA PRESSIONE
 Radial driven tool high pressure
 Radial angetriebenes Werkzeug hochdruck

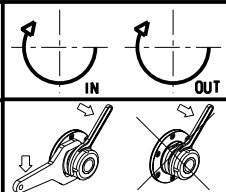

M.T. srl
 Via Casino Albini 480
 Tel. 0541/956034-957884
 Fax 0541/956341
 47842 S. GIOVANNI IN M. (RN)
 e-mail: mtma@mtmarchetti.com
 http://www.mtmarchetti.com



PAGINA MNL010-1-20

Subject to change without notice.

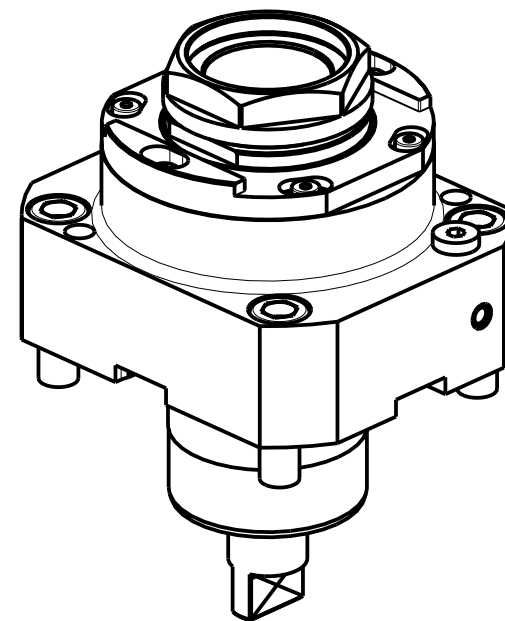
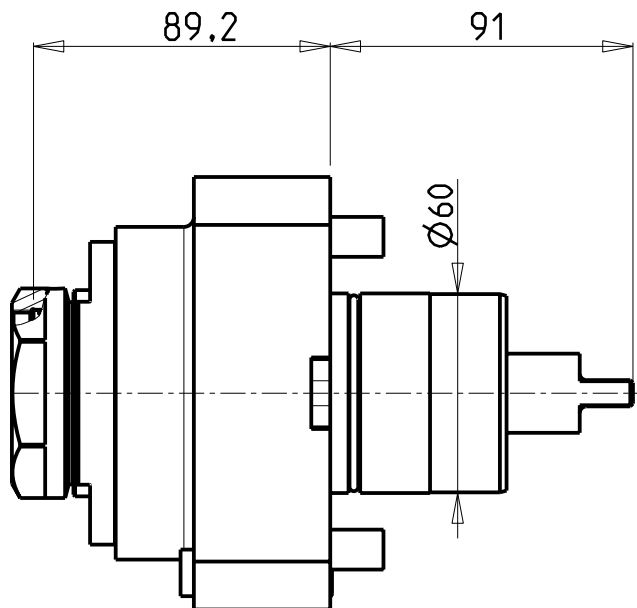
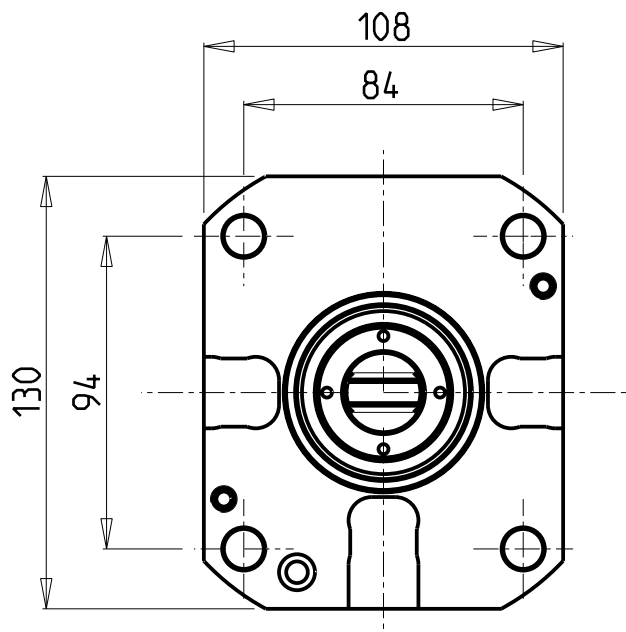

PER PORTAUTENSILI MODULARI MTSK-50 VEDI PAG. TBL300-1-50
 FOR MTSK-50 QUICK CHANGE TOOLHOLDERS CLAMPINGS SEE PAGE TBL300-1-50
 FUER MTSK-50 MODULARE WERKZEUGAUFNAHMEN SIEHE SEITE TBL300-1-50

Cod. MT	Mandrino Spindle Spindel	I	RPM	Coppia Max Max Torque Max Drehmoment	Lubrificazione int. Coolant through Innenkuehlung	Lubrificazione est. Ext. coolant Aussenkuehlung	CHIAVI NON INCLUSE Keys not included Schlüssel nicht einbegriffen	
MNL0590250	MTSK-50	1:1	6000	100Nm	P=80bar	X	CHUB55	OKU0430007 ▪

- Chiave inclusa
- Key included
- Schlüssel inbegriffen

DMG-MORI

NL1500/2000/2500/3000 12 STAZIONI - NLX1500/2000/2500/3000 12 STAZIONI - NLX4000 - NZL2000/2500 - NZX2500 (BMT60)
 NT4200/4250/4300/5400 - NTX2000/2500/3000 2ND GEN. 10ST. - CTX2500 (BMT60)

MODULO MOTORIZZATO RADIALE MTSK ALTA PRESSIONE

Radial MTSK driven tool high pressure
 Radial MTSK angetriebenes Werkzeug hochdruck

Subject to change without notice.

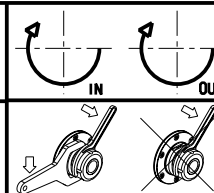

M.T. srl

Via Casino Albini 480
 Tel. 0541/956034-957884
 Fax 0541/956341
 47842 S. GIOVANNI IN M. (RN)
 e-mail: mtma@mtmarchetti.com
 http://www.mtmarchetti.com



PAGINA MNL010-1-20-K

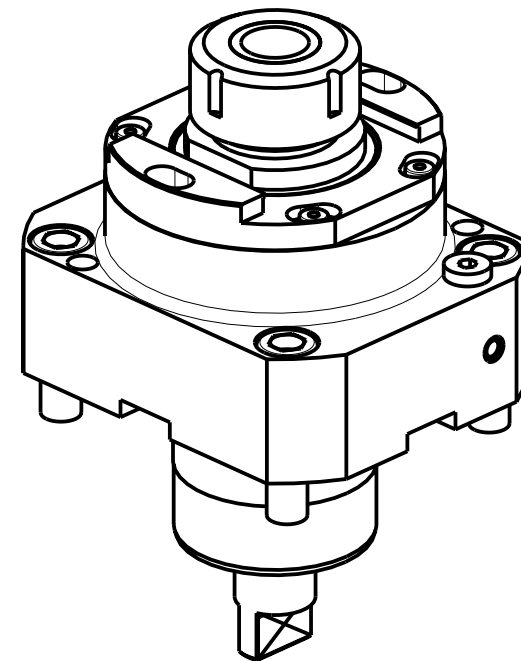
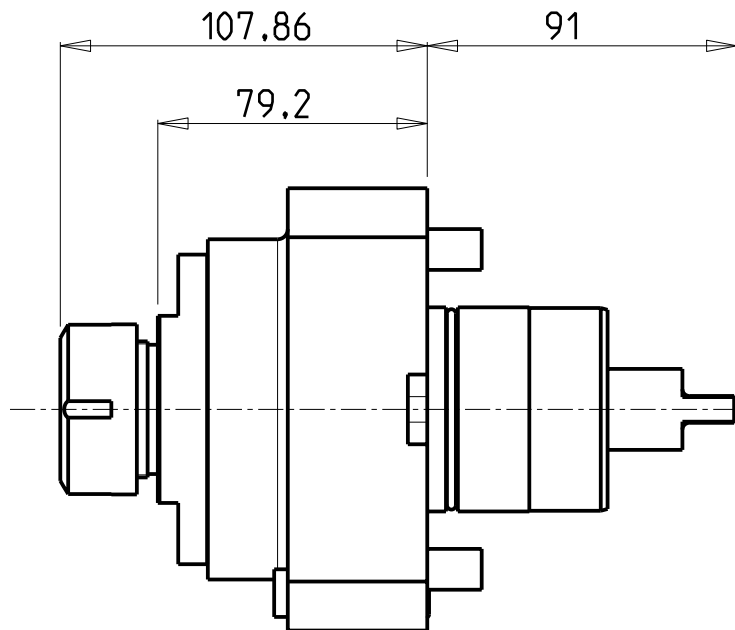
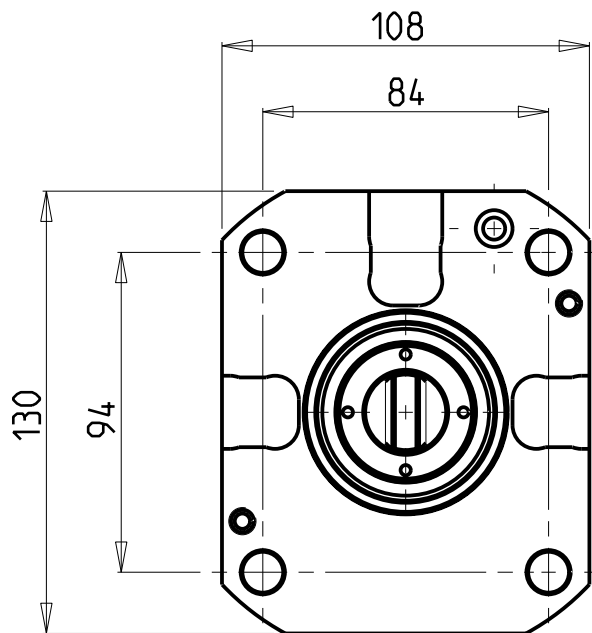

Cod. MT	Mandrino Spindle Spindel	I	RPM	Coppia Max Max Torque Max Drehmoment	Lubrificazione int. Coolant through Innenkuehlung	Lubrificazione est. Ext. coolant Aussenkuehlung	CHIAVI NON INCLUSE Keys not included Schluessel nicht einbegriffen	
MNL0770125	ER25	1:1	10000	100Nm	P=30bar	X	OKU0650004 *	CHSTER25
MNL0770132	ER32	1:1	10000	100Nm	P=30bar	X	OKU0650004 *	CHSTER32

- Chiave inclusa
- Key included
- Schluessel inbegriffen

DMG-MORI

NL1500/2000/2500/3000 12 STAZIONI - NLX1500/2000/2500/3000 12 STAZIONI - NLX4000 - NZL2000/2500 - NZX2500 (BMT60)
 NT4200/4250/4300/5400 - NTX2000/2500/3000 2ND GEN. 10ST. - CTX2500 (BMT60)

MODULO MOTORIZZATO RADIALE 10000 RPM

Radial driven tool 10000 rpm

Radial angetriebenes Werkzeug 10000 rpm

Subject to change without notice.

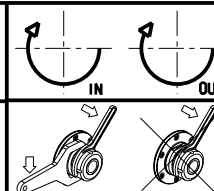

M.T. srl

Via Casino Albini 480
 Tel. 0541/956034-957884
 Fax 0541/956341
 47842 S. GIOVANNI IN M. (RN)
 e-mail: mtma@mtmarchetti.com
 http://www.mtmarchetti.com



PAGINA MNL010-1-21

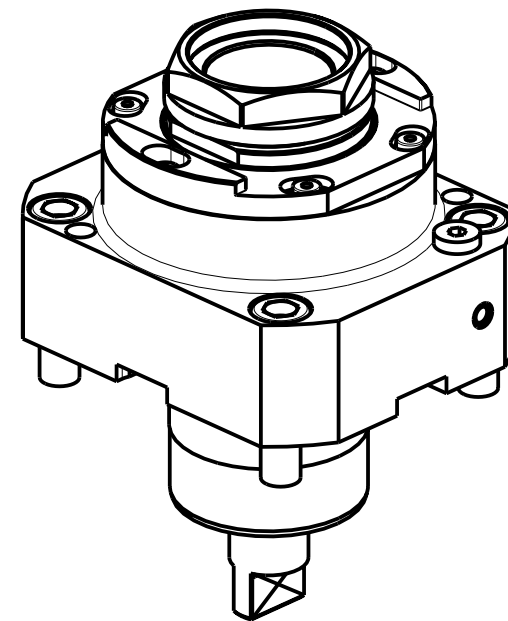
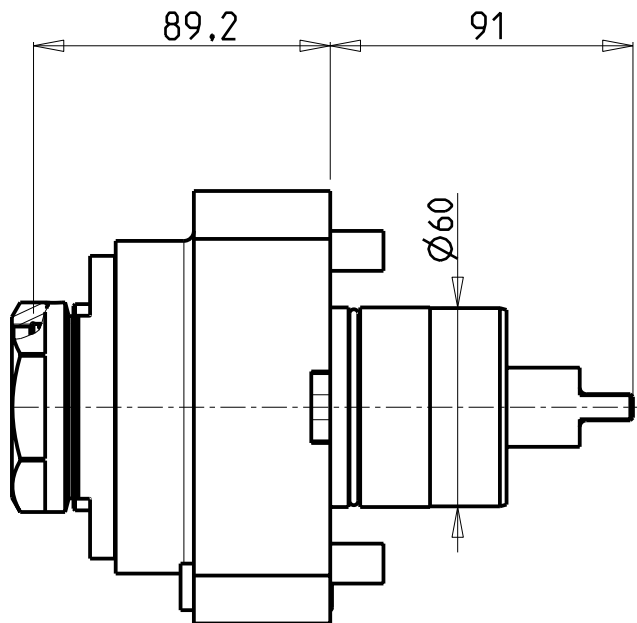
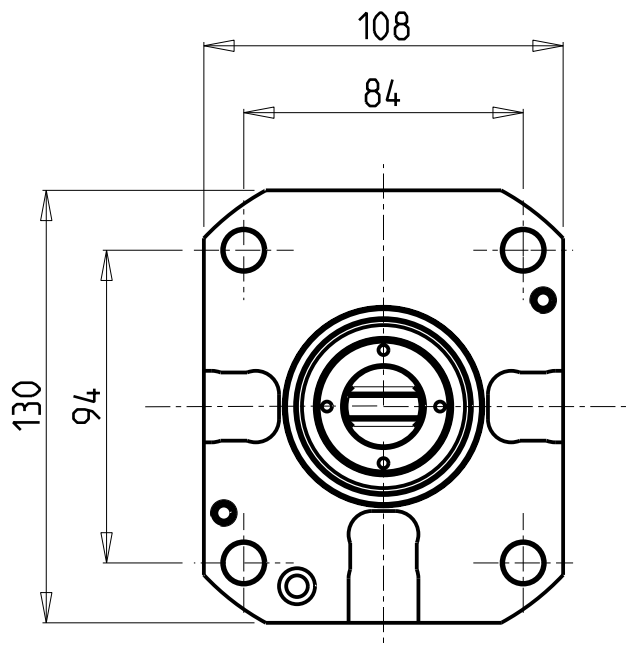

PER PORTAUTENSILI MODULARI MTSK-50 VEDI PAG. TBL300-1-50
 FOR MTSK-50 QUICK CHANGE TOOLHOLDERS CLAMPINGS SEE PAGE TBL300-1-50
 FUER MTSK-50 MODULARE WERKZEUGAUFNAHMEN SIEHE SEITE TBL300-1-50

Cod. MT	Mandrino Spindle Spindel	I	RPM	Coppia Max Max Torque Max Drehmoment	Lubrificazione int. Coolant through Innenkuehlung	Lubrificazione est. Ext. coolant Aussenkuehlung	CHIAVI NON INCLUSE Keys not included Schlüssel nicht einbegriffen	
MNL0790250	MTSK-50	1:1	10000	100Nm	P=30bar	X	CHUB55	OKU0430007 ▪

- Chiave inclusa
- Key included
- Schlüssel inbegriffen

DMG-MORI

NL1500/2000/2500/3000 12 STAZIONI - NLX1500/2000/2500/3000 12 STAZIONI - NLX4000 - NZL2000/2500 - NZX2500 (BMT60)
 NT4200/4250/4300/5400 - NTX2000/2500/3000 2ND GEN. 10ST. - CTX2500 (BMT60)

MODULO MOTORIZZATO RADIALE MTSK 10000 RPM
 Radial MTSK driven tool 10000 rpm
 Radial MTSK angetriebenes Werkzeug 10000 rpm

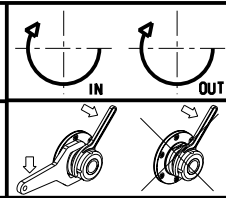

M.T. srl
 Via Casino Albini 480
 Tel. 0541/956034-957884
 Fax 0541/956341
 47842 S. GIOVANNI IN M. (RN)
 e-mail: mtma@mtmarchetti.com
 http://www.mtmarchetti.com



PAGINA MNL010-1-21-K

Subject to change without notice.

CUSCINETTI MAGGIORATI PER LAVORAZIONI PESANTI

Reinforced bearings for
heavy machining

Vergroesserte Lager fuer
schwerere Bearbeitungen

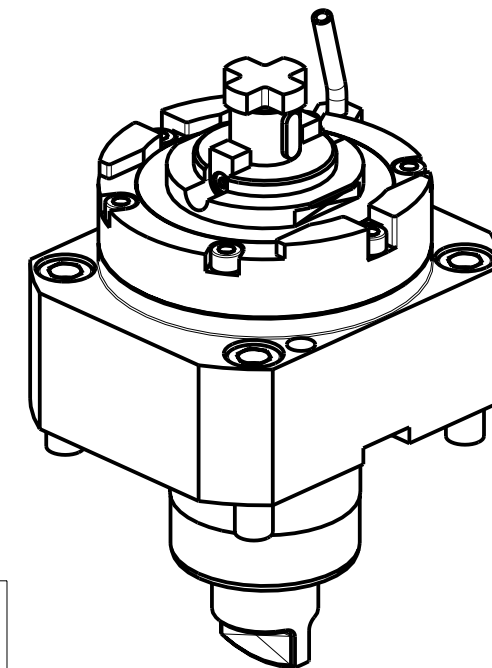
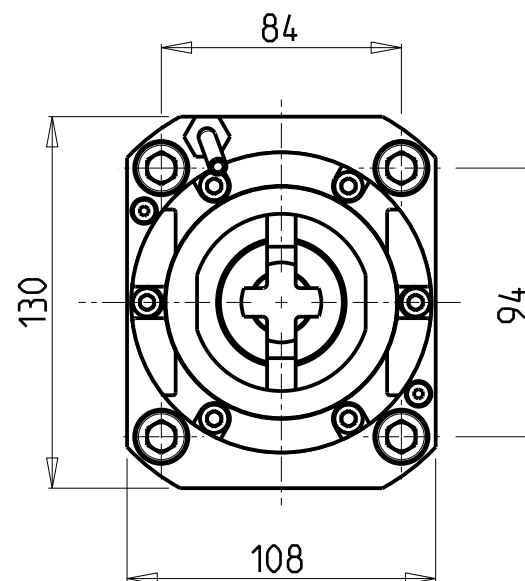
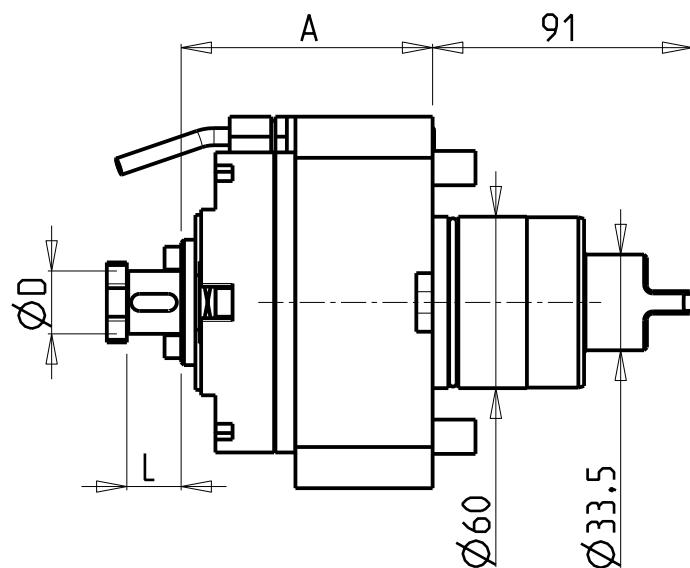

Cod. MT	Mandrino Spindle Spindel	I	RPM MAX	Coppia Max Max Torque Max Drehmoment	Lubrificazione est. Ext. coolant Auslenkuehlung	A	D	L	CHIAVI INCLUSE Keys included Schluessel inbegriffen	
MNL0732219	Ø22x19	1:1	4000	100Nm	X	88	22	19	CH_VTCROCE_M10	OKU0430007
MNL0732519	Ø1"x19	1:1	4000	100Nm	X	89	1"	19	CH_VTCROCE_M12	OKU0430007
MNL0732721	Ø27x21	1:1	4000	100Nm	X	89	27	21	CH_VTCROCE_M12	OKU0430007
MNL0733224	Ø32x24	1:1	4000	100Nm	X	91	32	24	CH_VTCROCE_M16	OKU0430007

DMG-MORI
NLX4000

MODULO MOTORIZZATO RADIALE MAGGIORATO
Radial reinforced driven tool
Radial angetriebenes Werkzeug vergroessert

Subject to change without notice.

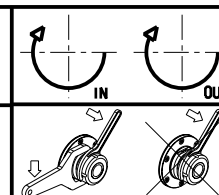

M.T. srl
Via Casino Albini 480
Tel. 0541/956034-957884
Fax 0541/956341
47842 S. GIOVANNI IN M. (RN)
e-mail: mtma@mtmarchetti.com
http://www.mtmarchetti.com



PAGINA MNL020-1-00

CUSCINETTI MAGGIORATI PER LAVORAZIONI PESANTI

Reinforced bearings for
heavy machining

Vergroesserte Lager fuer
schwerere Bearbeitungen

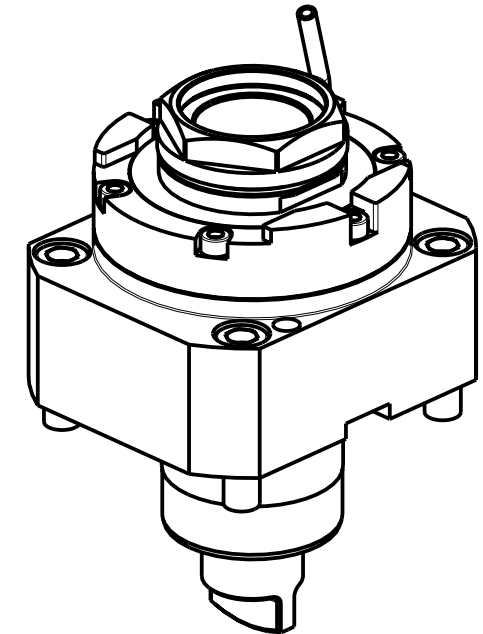
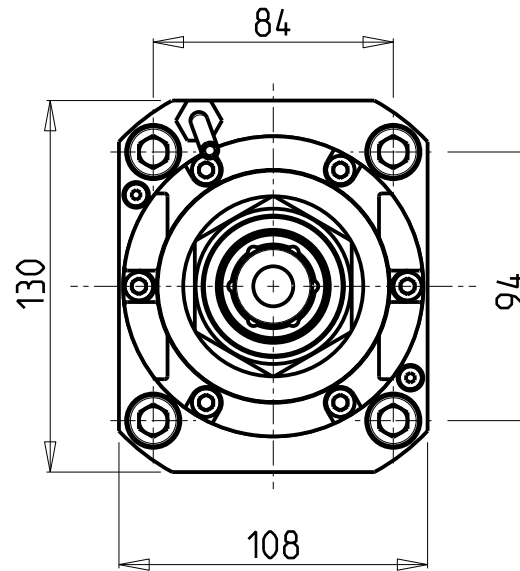
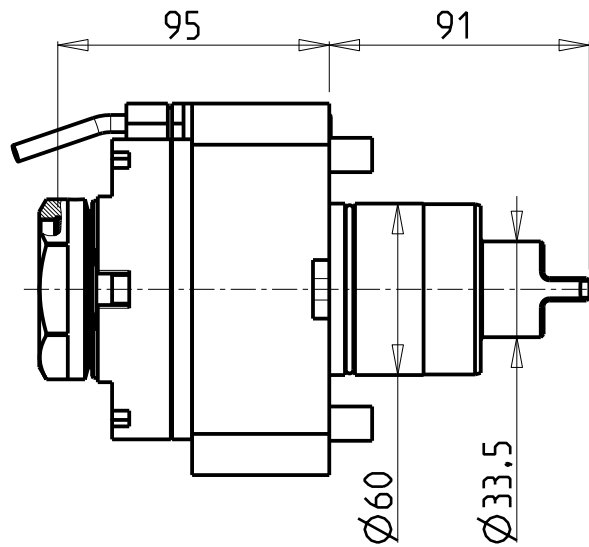

- Chiave inclusa
- Key included
- Schluessel inbegriffen

PER PORTAUTENSILI MODULARI MTSK-50 VEDI PAG. TBL300-1-50
FOR MTSK-50 QUIK CHANGE TOOLHOLDERS CLAMPINGS SEE PAGE TBL300-1-50
FUER MTSK-50 MODULARE WERKZEUGAUFNAHMEN SIEHE SEITE TBL300-1-50

Cod. MT	Mandrino Spindle Spindel	I	RPM MAX	Coppia Max Max Torque Max Drehmoment	Lubrificazione est. Ext. coolant Aussenkuehlung	CHIAVI NON INCLUSE Keys not included Schluessel nicht einbegriffen	
MNL0740150	MTSK-50	1:1	4000	100Nm	X	CHUB55	OKU0430007 ▪

DMG-MORI
NLX4000

MODULO MOTORIZZATO RADIALE MAGGIORATO MTSK
Radial MTSK reinforced driven tool
Radial MTSK angetriebenes Werkzeug vergroessert

Subject to change without notice.

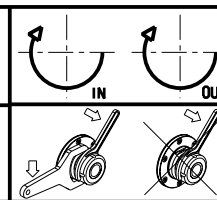

M.T. srl
Via Casino Albini 480
Tel. 0541/956034-957884
Fax 0541/956341
47842 S. GIOVANNI IN M. (RN)
e-mail: mtma@mtmarchetti.com
http://www.mtmarchetti.com



PAGINA MNL020-1-00-K

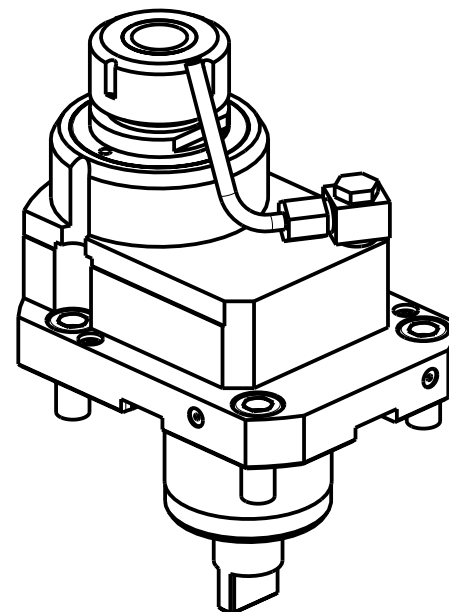
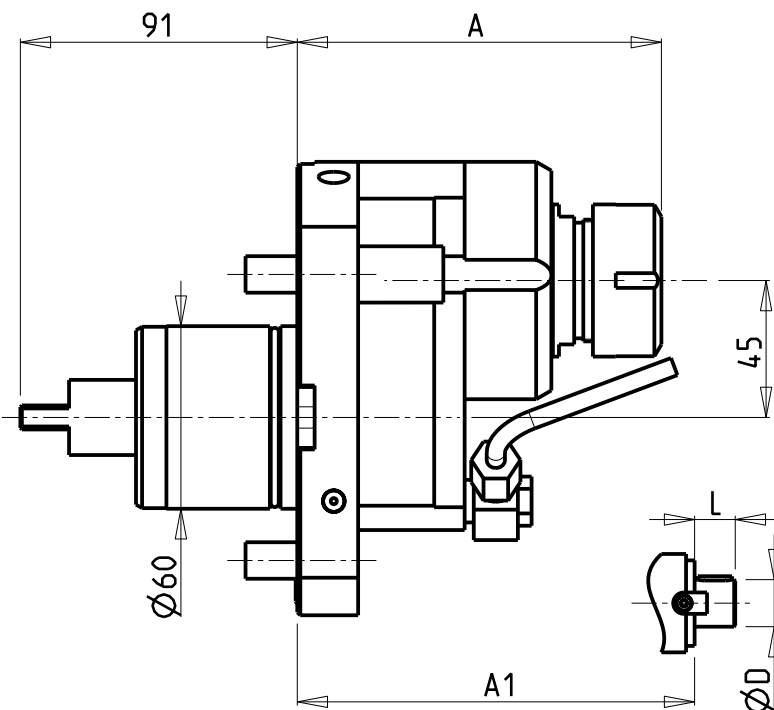
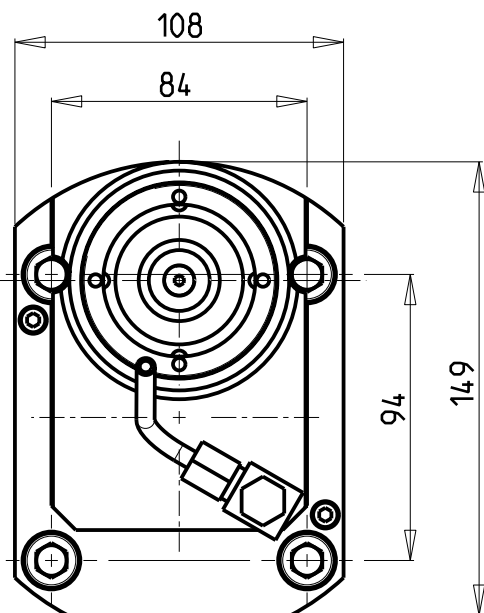

- Chiave inclusa
- Key included
- Schlüssel inbegriffen

Cod. MT	Mandrino Spindle Spindel	i	RPM	Coppia Max Max Torque Max Drehmoment	Reversibile lato mandrino/contromandrino Reversible sub/main spindle side Umkehrbare Spindel-seite/ Gegenspindel-seite	Lubr.esterna Ext. coolant Aussehenkuehlung	A	A1	D	L	CHIAVI NON INCLUSE Keys not included Schlüssel nicht einbegriffen	
MNL0342132	ER32	2:1	3000	100Nm	X	X	119.66	-	-	-	CHUB36	CHSTER32
MNL0342122	Ø22x19	2:1	3000	100Nm	X	X	-	98	22	19	CHUB36	CH_VTCROCE_M10
MNL0342127	Ø27x21	2:1	3000	100Nm	X	X	-	98	27	21	CHUB36	CH_VTCROCE_M12
MNL0342119	Ø3/4"x3/4"	2:1	3000	100Nm	X	X	-	98	3/4"	3/4"	CHUB36	CH_VTCROCE_M08
MNL0342125	Ø1"x19	2:1	3000	100Nm	X	X	-	98	1"	19	CHUB36	CH_VTCROCE_M12

DMG-MORI

NL1500/2000/2500/3000 12 STAZIONI - NLX1500/2000/2500/3000 12 STAZIONI - NLX4000 - NZL2000/2500 - NZX2500 (BMT60)
 NT4200/4250/4300/5400 - NTX2000/2500/3000 2ND GEN. 10ST. - CTX2500 (BMT60)

MODULO MOTORIZZATO RADIALE RIDOTTO I=2:1 DISASSATO IN Z 45mm

Radial geared-down I=2:1 driven tool re-directed in Z by 45mm

Radial angetriebenes Werkzeug untersetzt I=2:1 achsversetzt in Z um 45mm

Subject to change without notice.

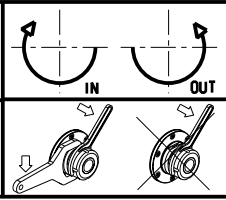

M.T. srl
 Via Casino Albini 480
 Tel. 0541/956034-957884
 Fax 0541/956341
 47842 S. GIOVANNI IN M. (RN)
 e-mail: mtma@mtmarchetti.com
 http://www.mtmarchetti.com



PAGINA MNL030-1-20

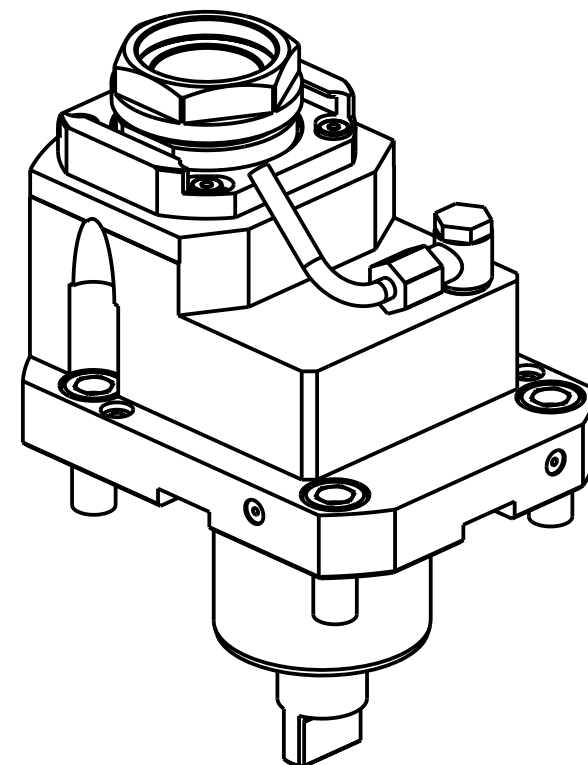
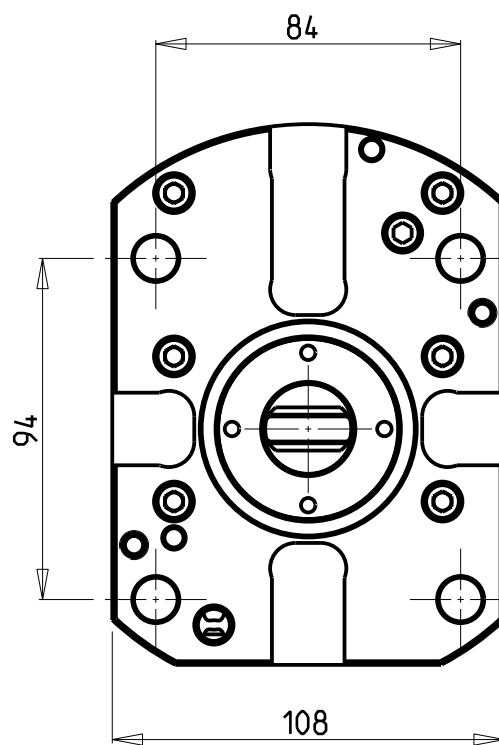
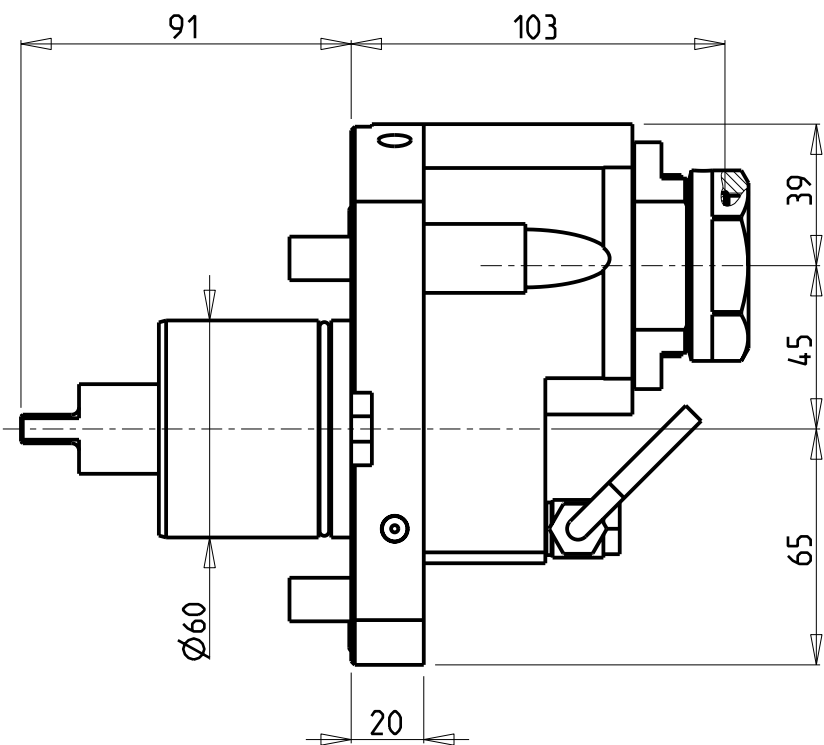

PER PORTAUTENSILI MODULARI MTSK-40 VEDI PAG. TBL300-1-40
 FOR MTSK-40 QUICK CHANGE TOOLHOLDERS CLAMPINGS SEE PAGE TBL300-1-40
 FUER MTSK-40 MODULARE WERKZEUGAUFNAHMEN SIEHE SEITE TBL300-1-40

Cod. MT	Mandrino Spindle Spindel	I	RPM	Coppia Max Max Torque Max Drehmoment	Reversibile lato mandrino/controlmandrino Reversible sub/main spindle side Umkehrbare Spindel-seite/ Gegenspindel-seite	Lubr.esterna Ext. coolant Aussenkuehlung	CHIAVI NON INCLUSE Keys not included Schlüssel nicht einbegriffen	
MNL1220140	MTSK-40	2:1	3000	100Nm	X	X	CHUB46	MNZ0410005 *

- Chiave inclusa
- Key included
- Schlüssel inbegriffen

DMG-MORI
 NL1500/2000/2500/3000 12 STAZIONI - NLX1500/2000/2500/3000 12 STAZIONI - NLX4000 - NZL2000/2500 - NZX2500 (BMT60)
 NT4200/4250/4300/5400 - NTX2000/2500/3000 2ND GEN. 10ST. - CTX2500 (BMT60)

MODULO MOTORIZZATO RADIALE MTSK RIDOTTO I=2:1 DISASSATO IN Z 45mm
 Radial MTSK geared-down I=2:1 driven tool re-directed in Z by 45mm
 Radial MTSK angetriebenes Werkzeug untersetzt I=2:1 achsversetzt in Z um 45mm

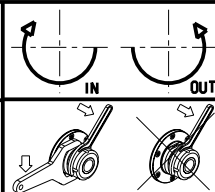

M.T. srl
 Via Casino Albini 480
 Tel. 0541/956034-957884
 Fax 0541/956341
 47842 S. GIOVANNI IN M. (RN)
 e-mail: mtma@mtmarchetti.com
 http://www.mtmarchetti.com



PAGINA MNL030-1-20-K

Subject to change without notice.

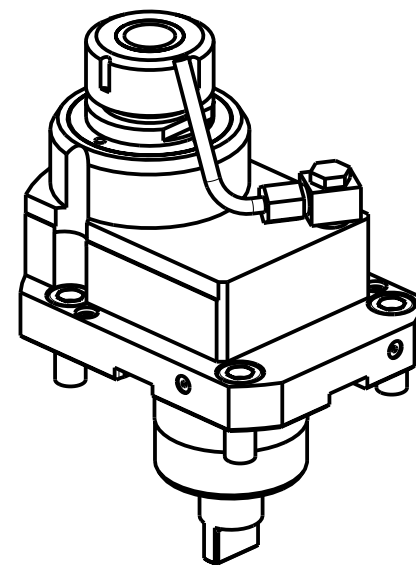
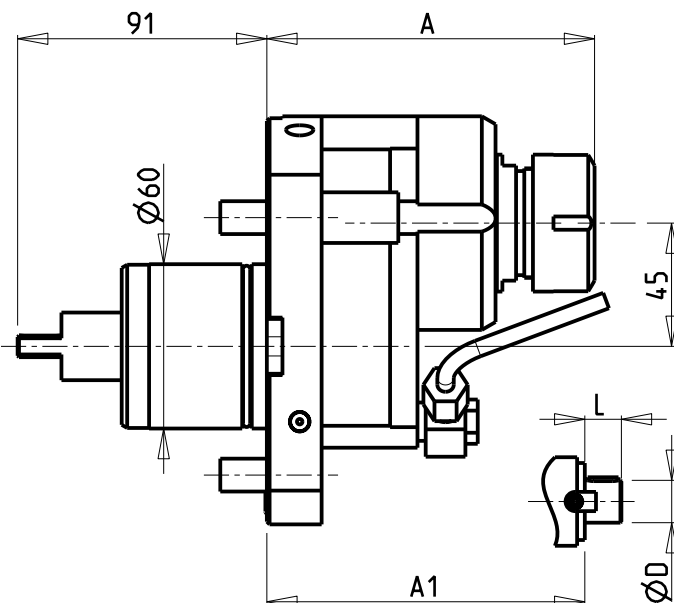
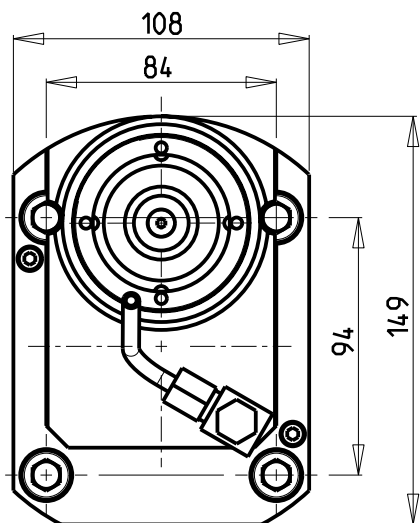

- Chiave inclusa
- Key included
- Schlüssel inbegriffen

Cod. MT	Mandrino Spindle Spindel	I	RPM	Coppia Max Max Torque Max Drehmoment	Reversibile lato mandrino/contromandrino Reversible sub/main spindle side Umkehrbare Spindel-seite/ Gegenspindel-seite	Lubrificazione int. Coolant through Innenkuehlung	Lubr. esterna Ext. coolant Aussenkuehlung	A	A1	D	L	CHIAVI NON INCLUDE Keys not included Schluessel nicht einbegriffen	
												CHUB42	CHSTER20
MNL0340120	ER20	1:1	6000	100Nm	X	-	X	115.66	-	-	-	CHUB42	CHSTER20
MNL0340032	ER32	1:1	6000	100Nm	X	-	X	119.66	-	-	-	CHUB42	CHSTER32
MNL0340220	ER20	1:1	6000	100Nm	X	P=70bar	X	126.66	-	-	-	CHUB42	CHSTER20
MNL0340132	ER32	1:1	6000	100Nm	X	P=70bar	X	131.16	-	-	-	CHUB42	CHSTER32
MNL0341116	Ø16x17	1:1	6000	100Nm	X	-	X	-	98	16	17	CHUB42	CH_VTCROCE_M08 ▪
MNL0341122	Ø22x19	1:1	6000	100Nm	X	-	X	-	98	22	19	CHUB42	CH_VTCROCE_M10 ▪
MNL0341127	Ø27x21	1:1	6000	100Nm	X	-	X	-	98	27	21	CHUB42	CH_VTCROCE_M12 ▪
MNL0341119	Ø3/4"x3/4"	1:1	6000	100Nm	X	-	X	-	98	3/4"	3/4"	CHUB42	CH_VTCROCE_M08 ▪
MNL0342225	Ø1"x19	1:1	6000	100Nm	X	-	X	-	98	1"	19	CHUB42	CH_VTCROCE_M12 ▪

DMG-MORI

NL1500/2000/2500/3000 12 STAZIONI - NLX1500/2000/2500/3000 12 STAZIONI - NLX4000 - NZL2000/2500 - NZX2500 (BMT60)
 NT4200/4250/4300/5400 - NTX2000/2500/3000 2ND GEN. 10ST. - CTX2500 (BMT60)

MODULO MOTORIZZATO RADIALE DISASSATO IN Z 45mm

Radial driven tool re-directed in Z by 45mm

Radial angetriebenes Werkzeug achsversetzt in Z um 45mm

Subject to change without notice.

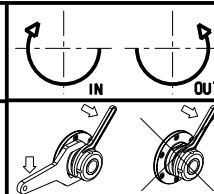

M.T. srl

Via Casino Albini 480
 Tel. 0541/956034-957884
 Fax 0541/956341

47842 S. GIOVANNI IN M. (RN)
 e-mail: mtma@mtmarchetti.com
 http://www.mtmarchetti.com



PAGINA MNL033-1-10

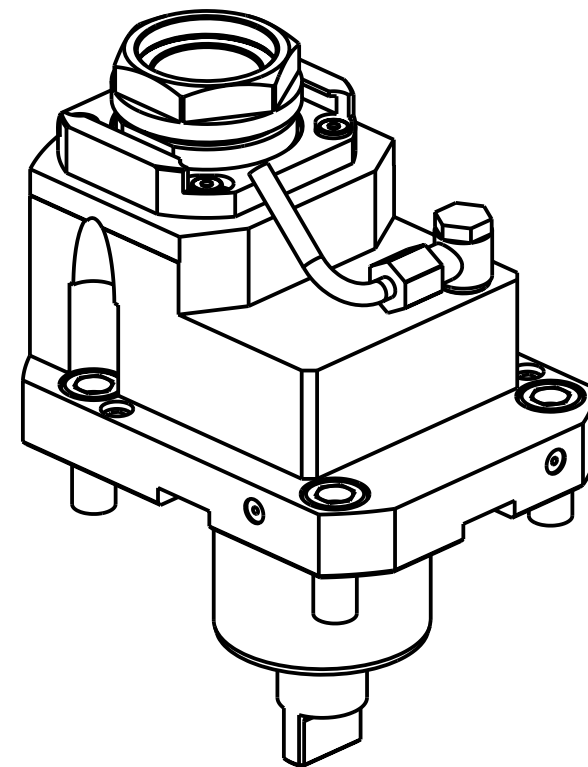
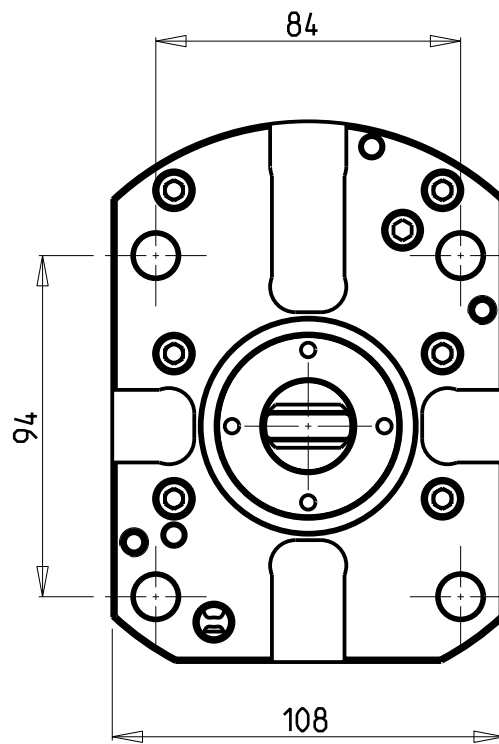
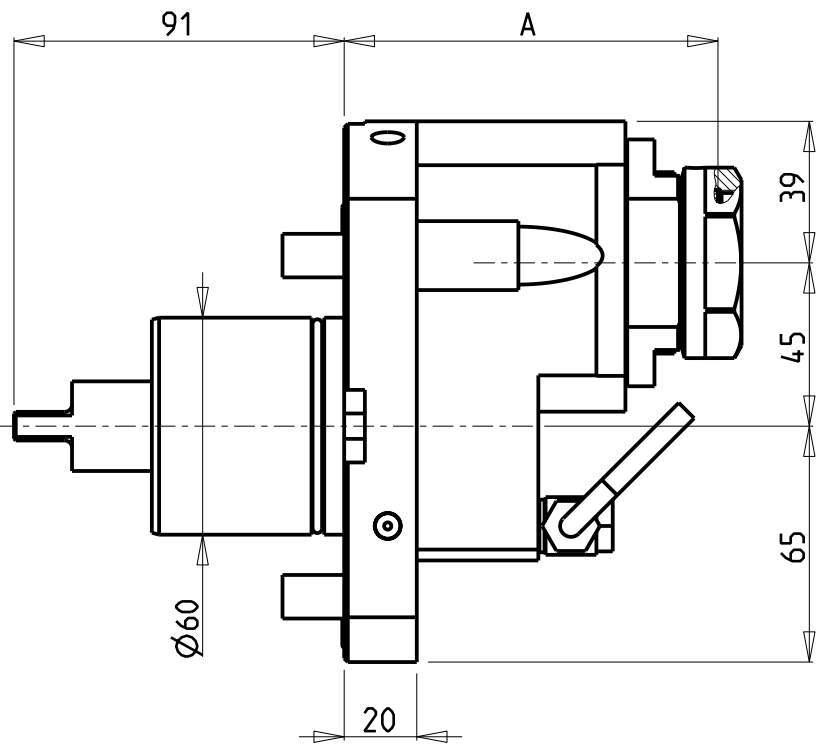

PER PORTAUTENSILI MODULARI MTSK-40 VEDI PAG. TBL300-1-40
 FOR MTSK-40 QUICK CHANGE TOOLHOLDERS CLAMPINGS SEE PAGE TBL300-1-40
 FUER MTSK-40 MODULARE WERKZEUGAUFNAHMEN SIEHE SEITE TBL300-1-40

Cod. MT	Mandrino Spindle Spindel	I	RPM	Coppia Max Max Torque Max Drehmoment	Reversibile lato mandrino/contromandrino Reversible sub/main spindle side Umkehrbare Spindel-seite/ Gegenspindel-seite	Lubrificazione int. Coolant through Innenkuehlung	Lubr. esterna Ext. coolant Aussenkuehlung	A	CHIAVI NON INCLUSE Keys not included Schlüssel nicht einbegriffen	
MNL1210140	MTSK-40	1:1	6000	100Nm	X	-	X	103	CHUB46	MNZ0410005 *
MNL1210240	MTSK-40	1:1	6000	100Nm	X	P=70bar	X	114	CHUB46	MNZ0410005 *

- Chiave inclusa
- Key included
- Schlüssel inbegriffen

DMG-MORI
 NL1500/2000/2500/3000 12 STAZIONI - NLX1500/2000/2500/3000 12 STAZIONI - NLX4000 - NZL2000/2500 - NZX2500 (BMT60)
 NT4200/4250/4300/5400 - NTX2000/2500/3000 2ND GEN. 10ST. - CTX2500 (BMT60)

MODULO MOTORIZZATO RADIALE MTSK DISASSATO IN Z 45mm
 Radial MTSK driven tool re-directed in Z by 45mm
 Radial MTSK angetriebenes Werkzeug achsversetzt in Z um 45mm

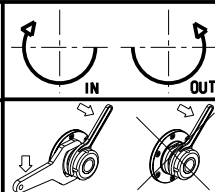

M.T. srl
 Via Casino Albini 480
 Tel. 0541/956034-957884
 Fax 0541/956341
 47842 S. GIOVANNI IN M. (RN)
 e-mail: mtma@mtmarchetti.com
 http://www.mtmarchetti.com



PAGINA MNL033-1-10-K

Subject to change without notice.

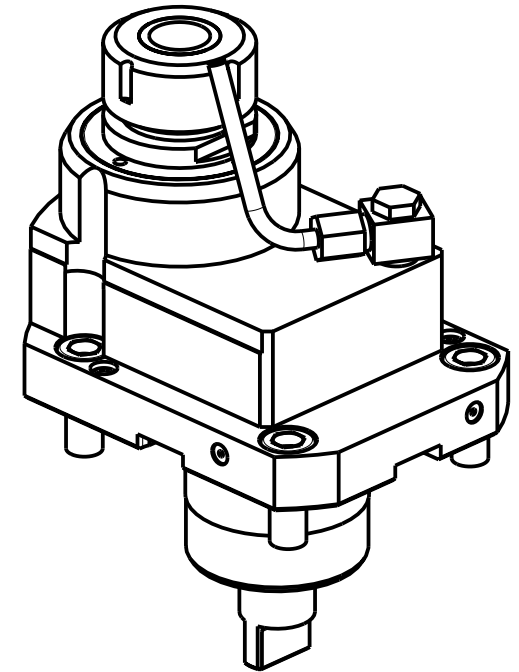
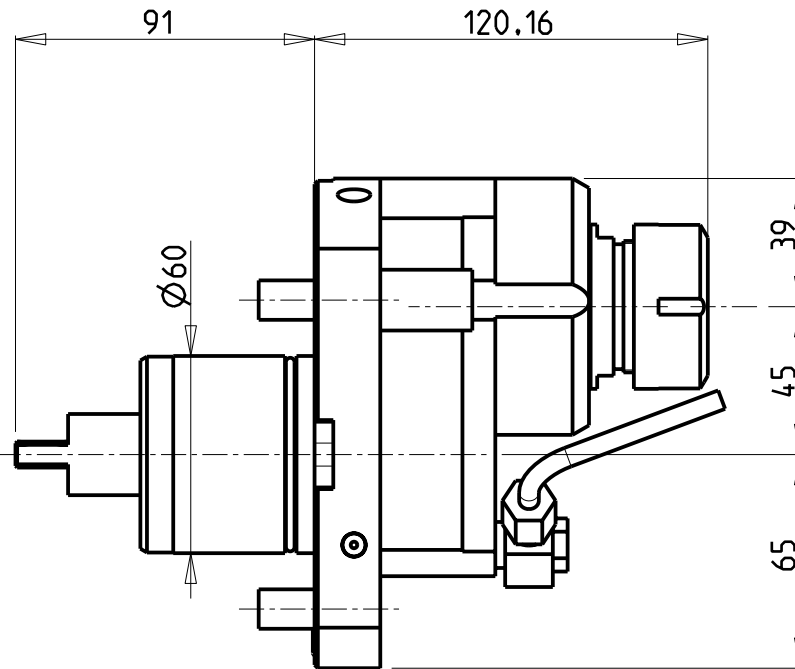
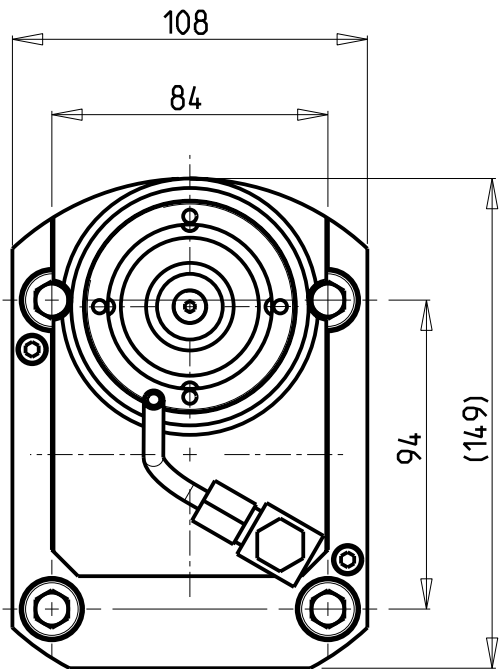

Cod. MT	Mandrino Spindle Spindel	I	RPM	Coppia Max Max Torque Max Drehmoment	Reversibile lato mandrino/contromandrino Reversible sub/main spindle side Umkehrbare Spindel-seite/ Gegenspindel-seite	Lubr. esterna Ext. coolant Aussenkuehlung	CHIAVI NON INCLUSE Keys not included Schlüssel nicht einbegriffen	
MNL1130132	ER32	1:1	10000	100Nm	X	X	CHUB42	CHSTER32

DMG-MORI

NL1500/2000/2500/3000 12 STAZIONI - NLX1500/2000/2500/3000 12 STAZIONI - NLX4000 - NZL2000/2500 - NZX2500 (BMT60)
 NT4200/4250/4300/5400 - NTX2000/2500/3000 2ND GEN. 10ST. - CTX2500 (BMT60)

MODULO MOTORIZZATO RADIALE DISASSATO IN Z 45mm 10000 RPM
 Radial driven tool re-directed in Z by 45mm 10000 rpm
 Radial angetriebenes Werkzeug achsversetzt in Z um 45mm 10000 rpm

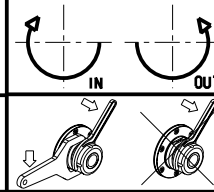

M.T. srl
 Via Casino Albini 480
 Tel. 0541/956034-957884
 Fax 0541/956341
 47842 S. GIOVANNI IN M. (RN)
 e-mail: mtma@mtmarchetti.com
 http://www.mtmarchetti.com



PAGINA MNLO33-1-11

Subject to change without notice.

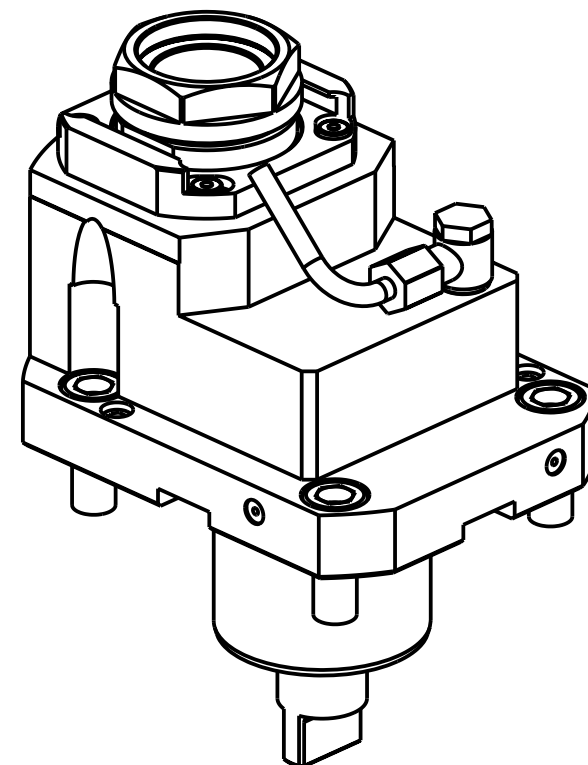
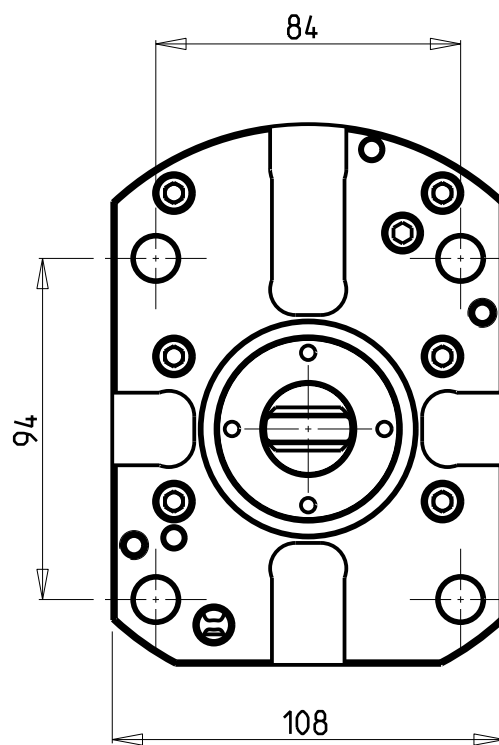
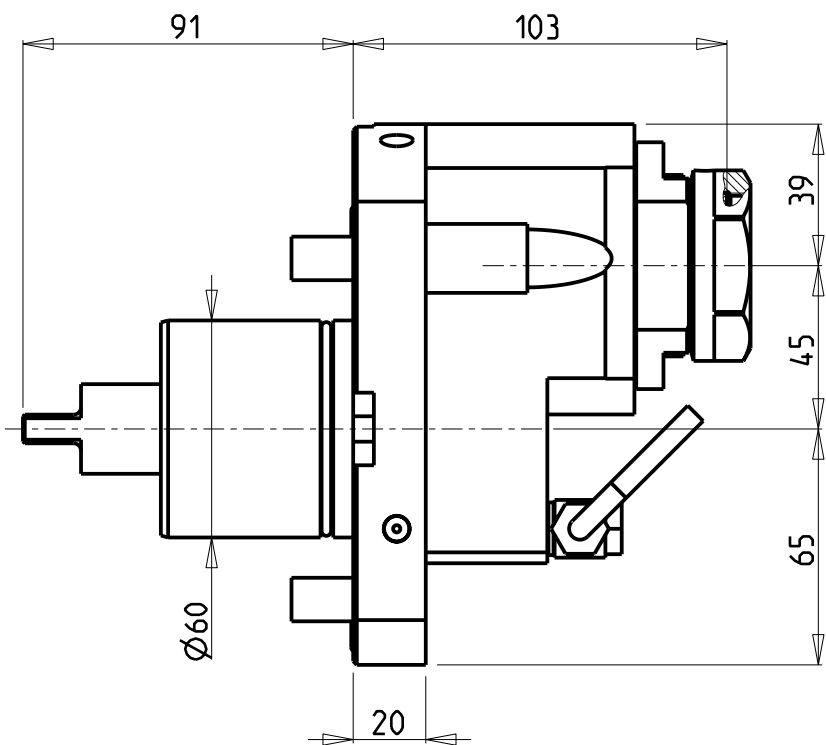

PER PORTAUTENSILI MODULARI MTSK-40 VEDI PAG. TBL300-1-40
 FOR MTSK-40 QUICK CHANGE TOOLHOLDERS CLAMPINGS SEE PAGE TBL300-1-40
 FUER MTSK-40 MODULARE WERKZEUGAUFNAHMEN SIEHE SEITE TBL300-1-40

Cod. MT	Mandrino Spindle Spindel	I	RPM	Coppia Max Max Torque Max Drehmoment	Reversibile lato mandrino/contromandrino Reversible sub/main spindle side Umkehrbare Spindel-seite/ Gegenspindel-seite	Lubr.esterna Ext. coolant Aussenkuehlung	CHIAVI NON INCLUSE Keys not included Schlüssel nicht einbegriffen	
MNL1200140	MTSK-40	1:1	10000	100Nm	X	X	CHUB46	MNZ0410005 *

- Chiave inclusa
- Key included
- Schlüssel inbegriffen

DMG-MORI

NL1500/2000/2500/3000 12 STAZIONI - NLX1500/2000/2500/3000 12 STAZIONI - NLX4000 - NZL2000/2500 - NZX2500 (BMT60)
 NT4200/4250/4300/5400 - NTX2000/2500/3000 2ND GEN. 10ST. - CTX2500 (BMT60)

MODULO MOTORIZZATO RADIALE MTSK DISASSATO IN Z 45mm 10000 RPM

Radial MTSK driven tool re-directed in Z by 45mm 10000 rpm

Radial MTSK angetriebenes Werkzeug achsversetzt in Z um 45mm 10000 rpm

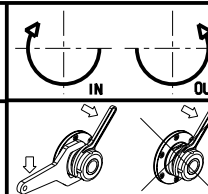

M.T. srl
 Via Casino Albini 480
 Tel. 0541/956034-957884
 Fax 0541/956341
 47842 S. GIOVANNI IN M. (RN)
 e-mail: mtma@mtmarchetti.com
 http://www.mtmarchetti.com



PAGINA MNL033-1-11-K

Subject to change without notice.

10/2021

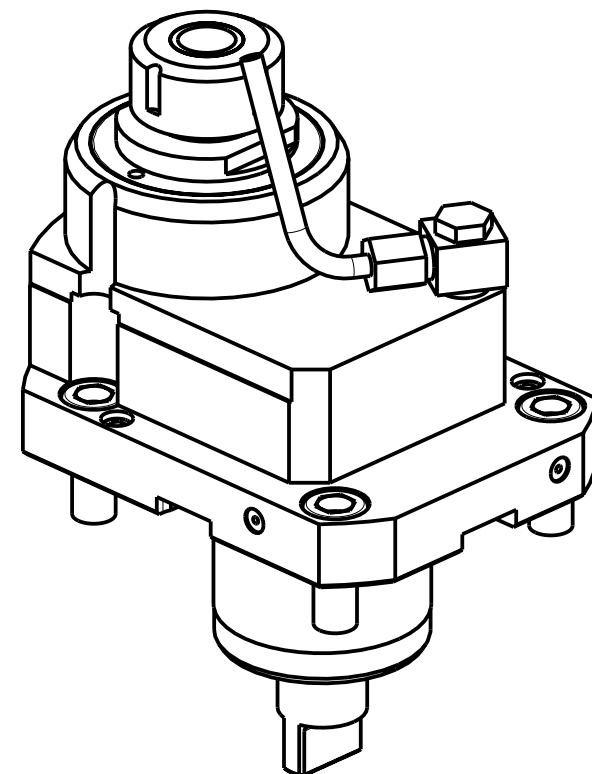
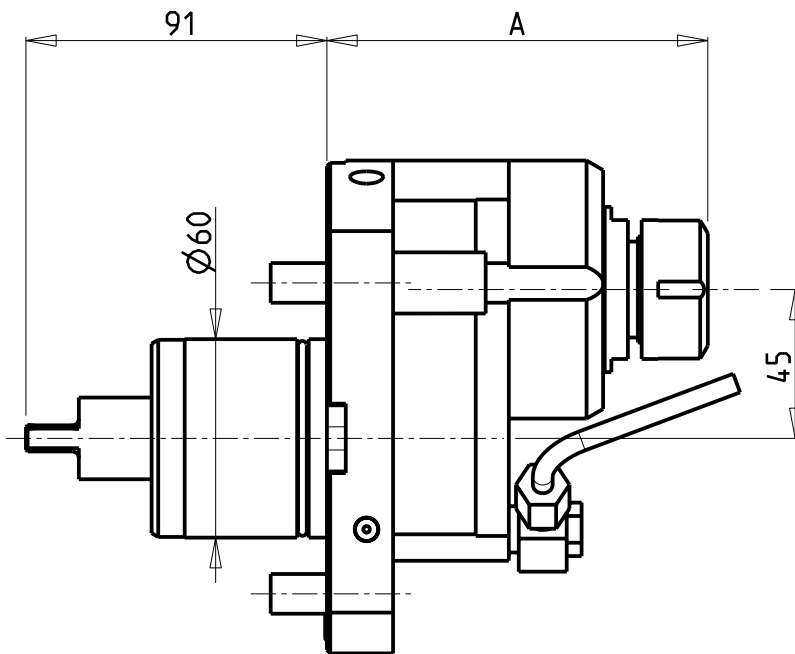
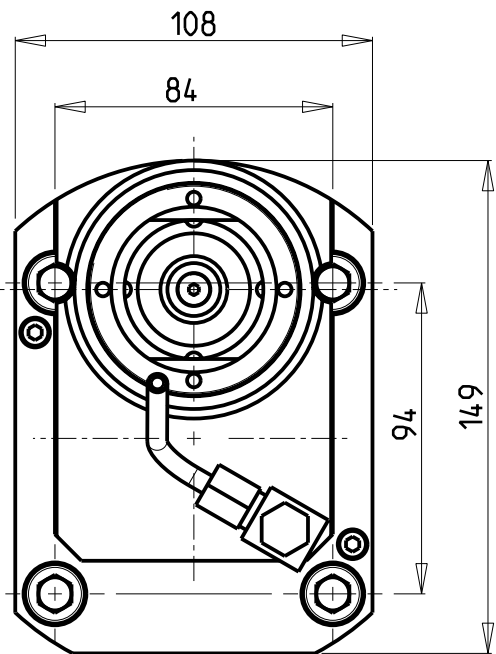

Cod. MT	Mandrino Spindle Spindel	i	RPM MAX	Coppia Max Max Torque Max Drehmoment	Reversibile lato mandrino/contromandrino Reversible sub/main spindle side Umkehrbare Spindel-seite/ Gegenspindel-seite	Lubrificazione int. Coolant through Innenkuehlung	Lubrificazione est. Ext. coolant Aussenkuehlung	A	CHIAVI NON INCLUSE Keys not included Schlüssel nicht einbegriffen	
MNL0341225	ER25	1:2	12000	40Nm	X	-	X	115.16	CHUB42	CHSTER25
MNL0342425	ER25	1:2	10000	40Nm	X	P=70bar	X	126.16	CHUB42	CHSTER25

DMG-MORI

NL1500/2000/2500/3000 12 STAZIONI - NLX1500/2000/2500/3000 12 STAZIONI - NLX4000 - NZL2000/2500 - NZX2500 (BMT60)
 NT4200/4250/4300/5400 - NTX2000/2500/3000 2ND GEN. 10ST. - CTX2500 (BMT60)

MODULO MOTORIZZATO RADIALE Moltiplicato I=1:2 DISASSATO IN Z 45mm

Radial geared-up I=1:2 driven tool re-directed in Z by 45mm

Radial angetriebenes Werkzeug uebersetzt I=1:2 achsversetzt in Z um 45mm

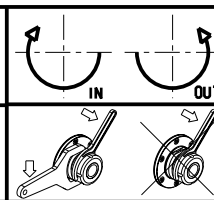

M.T. srl

Via Casino Albini 480
 Tel. 0541/956034-957884
 Fax 0541/956341

47842 S. GIOVANNI IN M. (RN)
 e-mail: mtma@mtmarchetti.com
 http://www.mtmarchetti.com



PAGINA MNL033-1-30

Subject to change without notice.

10/2021

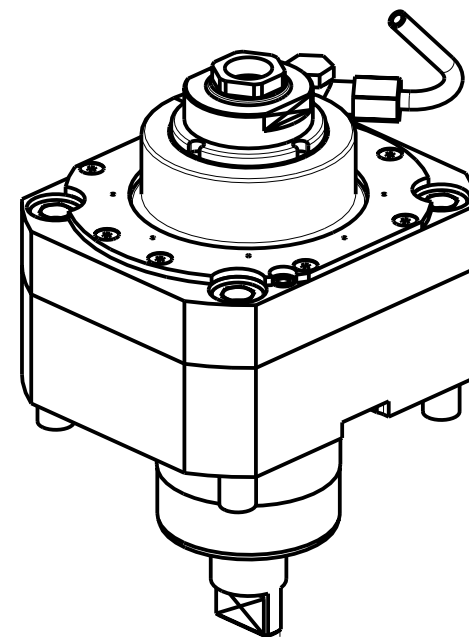
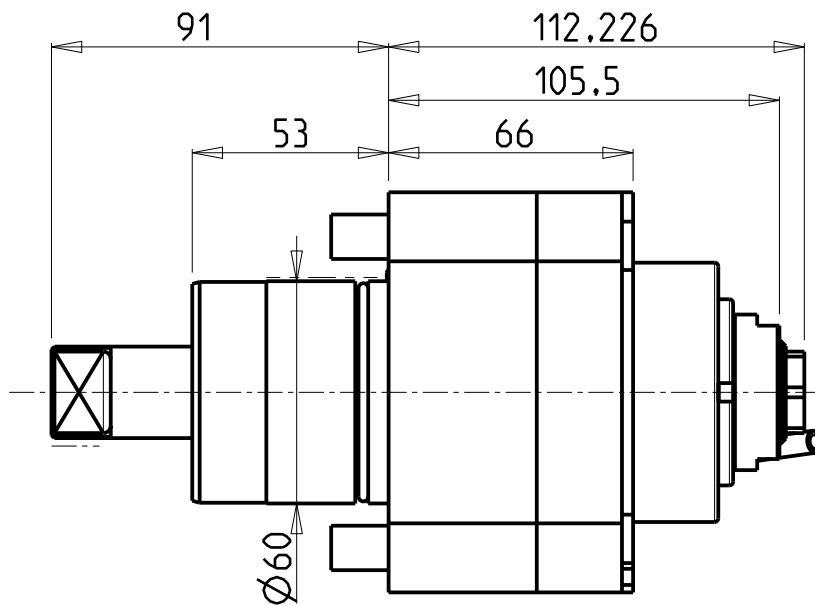
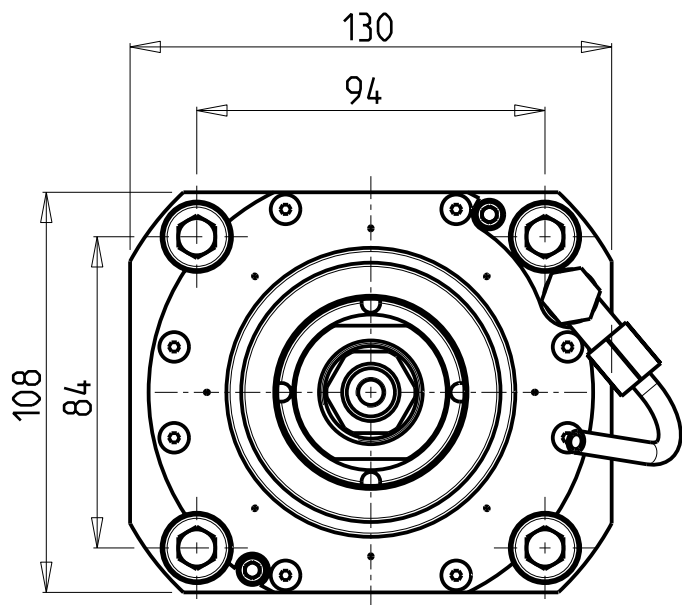

ATTENZIONE - ATTENTION - ACHTUNG

- PRIMA DI UTILIZZARE IL MOTORIZZATO CONSULTARE LE ISTRUZIONI ALLEGATE!
- BEFORE USING THE DRIVEN TOOL, PLEASE CHECK THE ENCLOSED INSTRUCTION SHEET!
- VOR DER BENUTZUNG DES ANGETRIEBENEN WERKZEUGES, DIE BEILIEGENDEN INSTRUKTIONEN DURCHLESEN!

ATTENZIONE - ATTENTION - ACHTUNG

- Per lo smontaggio degli utensili utilizzare sempre la chiave di contrasto come indicato nel manuale d'uso.
- For disassembly of the tools use always the contrast key as mentioned in the user instructions.
- Fuer das Abmontieren der Werkzeuge immer den Gegenschlüssel benutzen wie in der Bedienungsanleitung erwaeht.

Cod. MT	Mandrino Spindle Spindel	i	RPM	Coppia Max Max Torque Max Drehmoment	Lubrificazione est. Ext. coolant Aussenkuehlung	CHIAVI INCLUSE Keys included Schluessel einbegriffen	
						CHUB36	CHUB22
MNL0690120	ERA20	1:5	30000	15Nm	X	CHUB36	CHUB22

DMG-MORI

NL1500/2000/2500/3000 12 STAZIONI - NLX1500/2000/2500/3000 12 STAZIONI - NLX4000 - NZL2000/2500 - NZX2500 (BMT60)
 NT4200/4250/4300/5400 - NTX2000/2500/3000 2ND GEN. 10ST. - CTX2500 (BMT60)

MODULO MOTORIZZATO RADIALE MOLTIPLICATO I=1:5

Radial geared-up I=1:5 driven tool

Radial angetriebenes Werkzeug uebersetzt I=1:5

Subject to change without notice.

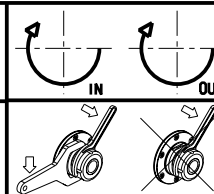

M.T. srl

Via Casino Albini 480
 Tel. 0541/956034-957884
 Fax 0541/956341

47842 S. GIOVANNI IN M. (RN)
 e-mail: mtma@mtmarchetti.com
 http://www.mtmarchetti.com



PAGINA MNL059-1-00

ATTENZIONE - ATTENTION - ACHTUNG

- Per lo smontaggio degli utensili utilizzare sempre la chiave di contrasto come indicato nel manuale d'uso.
- For disassembly of the tools use always the contrast key as mentioned in the user instructions.
- Fuer das Abmontieren der Werkzeuge immer den Gegenschlüssel benutzen wie in der Bedienungsanleitung erwäehnt.

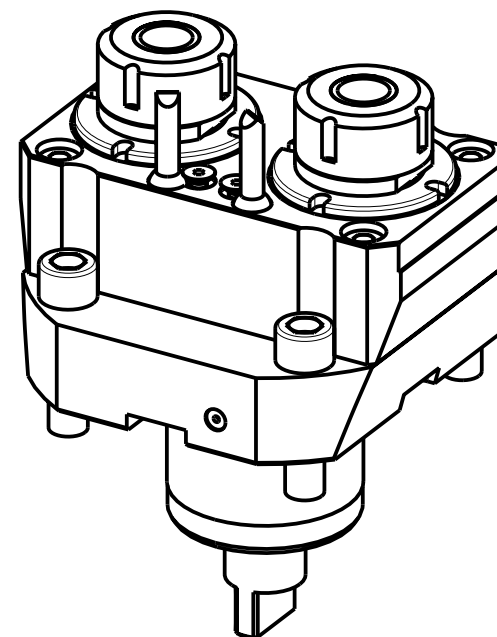
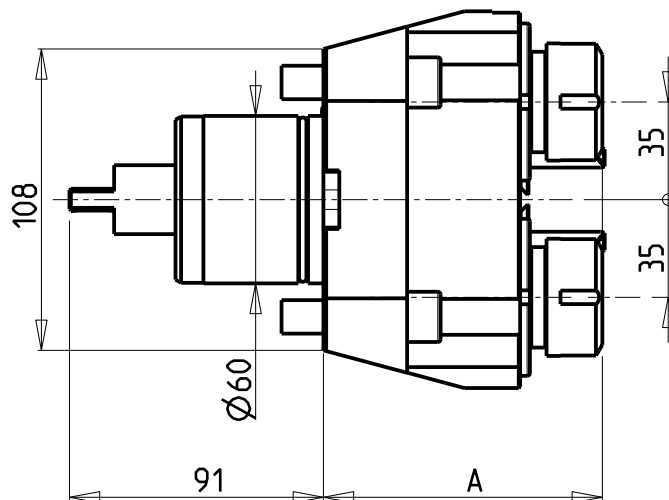
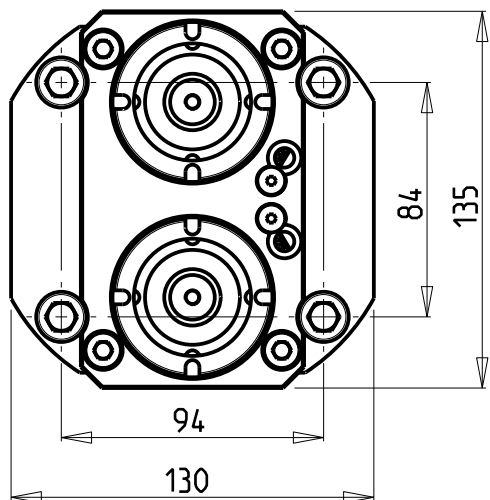

Cod. MT	Mandrino Spindle Spindel	I	RPM	Coppia Max Max Torque Max Drehmoment	Lubrificazione int. Coolant through Innenkuehlung	Lubrificazione est. Ext. coolant Aussenkuehlung	A	CHIAVI NON INCLUSE Keys not included Schlüssel nicht einbegriffen		
MNL0200225	ER25	1:1	6000	40Nm	-	X	99.96	CHUB36	CHSTER25	-
MNL0201225	ER25	1:1	6000	40Nm	P=70bar	X	115.2	CHUB36	CHSTER25	-
MNL0200325	ERA25	1:1	6000	40Nm	-	X	88.5	CHUB38	CHUB27	CHTAER25ZC • NEW
MNL0201325	ERA25	1:1	6000	40Nm	P=70bar	X	108.53	CHUB38	CHUB27	-

• Chiave inclusa
• Key included
• Schlüssel inbegriffen

DMG-MORI

NL1500/2000/2500/3000 12 STAZIONI - NLX1500/2000/2500/3000 12 STAZIONI - NLX4000 - NZL2000/2500 - NZX2500 (BMT60)
NT4200/4250/4300/5400 - NTX2000/2500/3000 2ND GEN. 10ST. - CTX2500 (BMT60)

MODULO MOTORIZZATO RADIALE 2 USCITE IN Y
Radial single side twin head driven tool in Y
Radial angetriebenes Werkzeug 2 Ausgaenge in Y

Subject to change without notice.

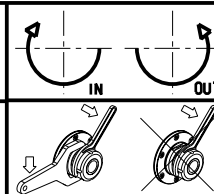

M.T. srl

Via Casino Albini 480
Tel. 0541/956034-957884
Fax 0541/956341
47842 S. GIOVANNI IN M. (RN)
e-mail: mtma@mtmarchetti.com
http://www.mtmarchetti.com



PAGINA MNL080-1-00

ATTENZIONE - ATTENTION - ACHTUNG

- Per lo smontaggio degli utensili utilizzare sempre la chiave di contrasto come indicato nel manuale d'uso.
- For disassembly of the tools use always the contrast key as mentioned in the user instructions.
- Fuer das Abmontieren der Werkzeuge immer den Gegenschlüssel benutzen wie in der Bedienungsanleitung erwäehnt.

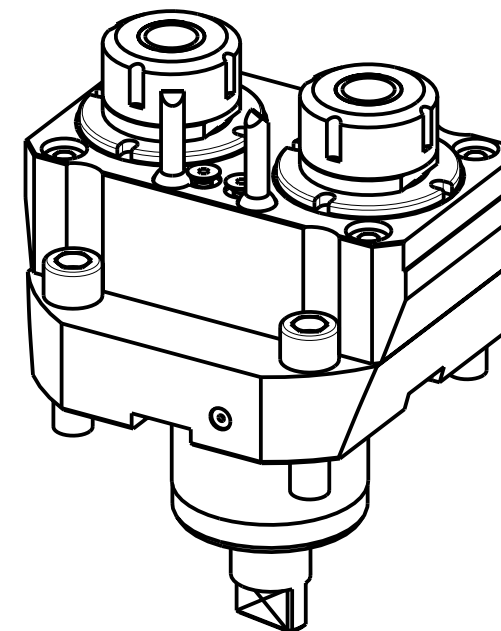
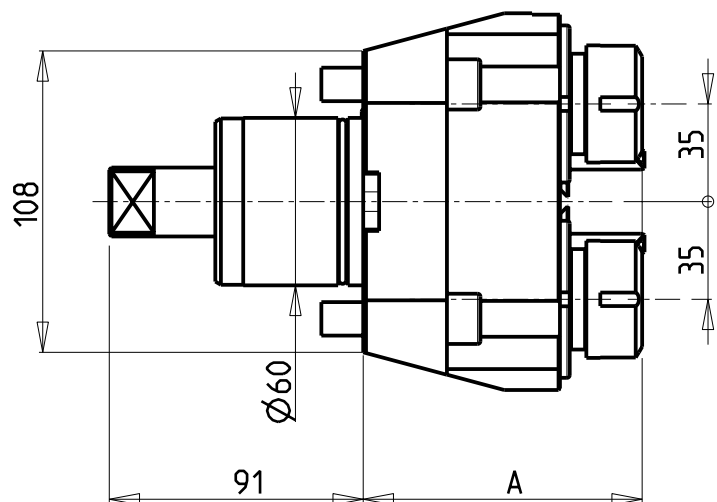
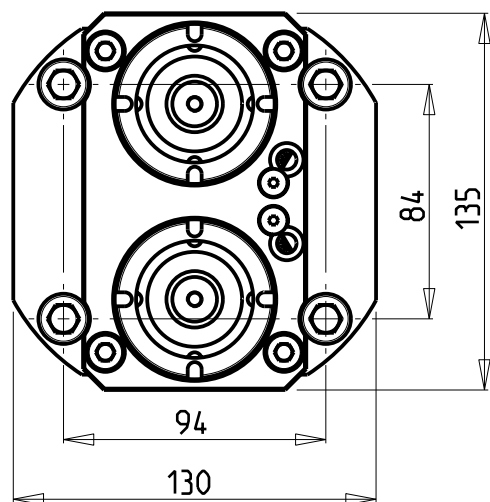

Cod. MT	Mandrino Spindle Spindel	I	RPM	Coppia Max Max Torque Max Drehmoment	Lubrificazione est. Ext. coolant Aussenkuehlung	A	CHIAVI NON INCLUDE Keys not included Schluesssel nicht einbegriffen		
MNL1070225	ER25	1:1	10000	40Nm	X	99.96	CHUB36	CHSTER25	-
MNL1070325	ERA25	1:1	10000	40Nm	X	88.5	CHUB38	CHUB27	CHTAER25ZC • NEW

- Chiave inclusa
- Key included
- Schluesssel inbegriffen

DMG-MORI

NL1500/2000/2500/3000 12 STAZIONI - NLX1500/2000/2500/3000 12 STAZIONI - NLX4000 - NZL2000/2500 - NZX2500 (BMT60)
NT4200/4250/4300/5400 - NTX2000/2500/3000 2ND GEN. 10ST. - CTX2500 (BMT60)

MODULO MOTORIZZATO RADIALE 2 USCITE IN Y 10000 RPM

Radial single side twin head driven tool in Y 10000 rpm

Radial angetriebenes Werkzeug 2 Ausgaenge in Y 10000 rpm

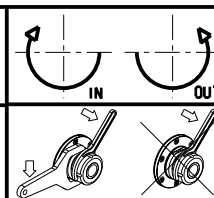

M.T. srl
Via Casino Albini 480
Tel. 0541/956034-957884
Fax 0541/956341
47842 S. GIOVANNI IN M. (RN)
e-mail: mtma@mtmarchetti.com
http://www.mtmarchetti.com



PAGINA MNL080-1-01

Subject to change without notice.

10/2021

ATTENZIONE - ATTENTION - ACHTUNG

- Per lo smontaggio degli utensili utilizzare sempre la chiave di contrasto come indicato nel manuale d'uso.
- For disassembly of the tools use always the contrast key as mentioned in the user instructions.
- Fuer das Abmontieren der Werkzeuge immer den Gegenschlüssel benutzen wie in der Bedienungsanleitung erwaeht.

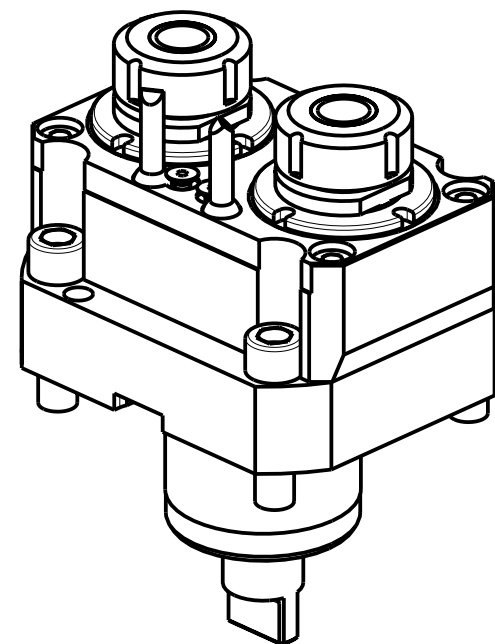
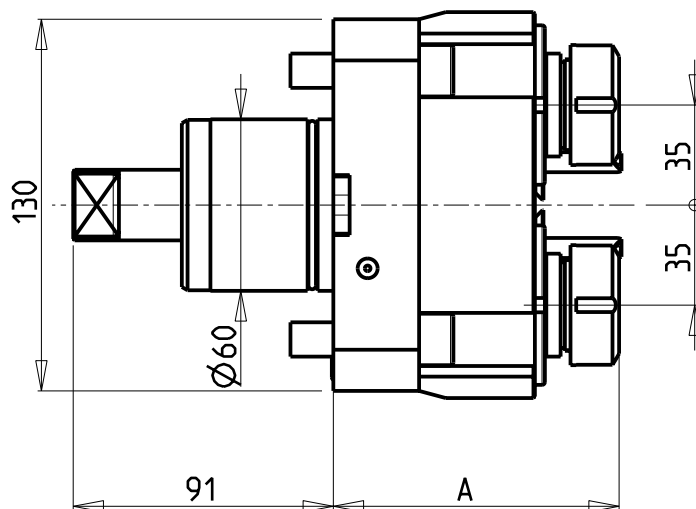
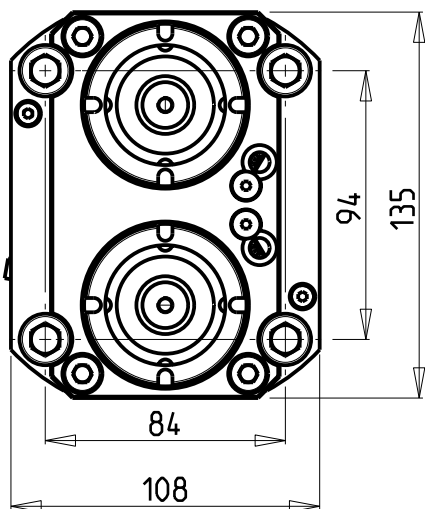

Cod. MT	Mandrino Spindle Spindel	I	RPM	Coppia Max Max Torque Max Drehmoment	Lubrificazione int. Coolant through Innenkuehlung	Lubrificazione est. Ext. coolant Aussenkuehlung	A	CHIAVI NON INCLUSE Keys not included Schlüssel nicht einbegriffen		
MNL0420225	ER25	1:1	6000	40Nm	-	X	99.96	CHUB36	CHSTER25	-
MNL0421225	ER25	1:1	6000	40Nm	P=70bar	X	115.2	CHUB36	CHSTER25	-
MNL0420325	ERA25	1:1	6000	40Nm	-	X	88.5	CHUB38	CHUB27	CHTAER25ZC • NEW
MNL0421325	ERA25	1:1	6000	40Nm	P=70bar	X	108.53	CHUB38	CHUB27	-

• Chiave inclusa
• Key included
• Schlüssel inbegriffen

DMG-MORI

NL1500/2000/2500/3000 12 STAZIONI - NLX1500/2000/2500/3000 12 STAZIONI - NLX4000 - NZL2000/2500 - NZX2500 (BMT60)
NT4200/4250/4300/5400 - NTX2000/2500/3000 2ND GEN. 10ST. - CTX2500 (BMT60)

MODULO MOTORIZZATO RADIALE 2 USCITE IN Z
Radial single side twin head driven tool in Z
Radial angetriebenes Werkzeug 2 Ausgaenge in Z

Subject to change without notice.

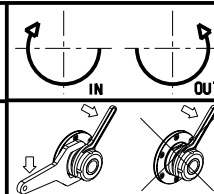

M.T. srl

Via Casino Albini 480
Tel. 0541/956034-957884
Fax 0541/956341
47842 S. GIOVANNI IN M. (RN)
e-mail: mtma@mtmarchetti.com
http://www.mtmarchetti.com



PAGINA MNL090-1-00

ATTENZIONE - ATTENTION - ACHTUNG

- Per lo smontaggio degli utensili utilizzare sempre la chiave di contrasto come indicato nel manuale d'uso.
- For disassembly of the tools use always the contrast key as mentioned in the user instructions.
- Fuer das Abmontieren der Werkzeuge immer den Gegenschlüssel benutzen wie in der Bedienungsanleitung erwaeht.

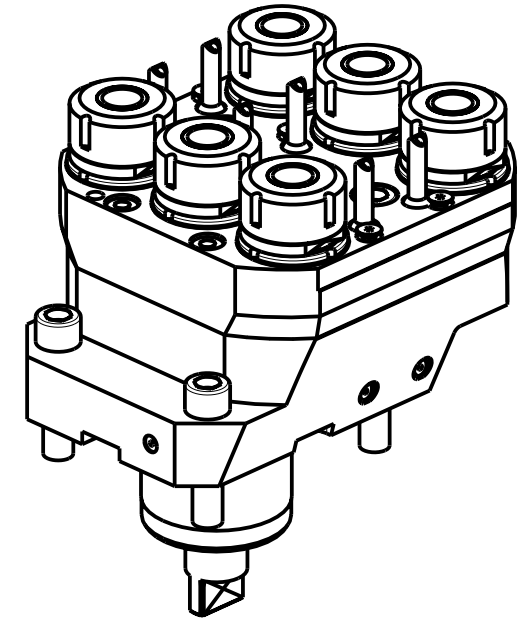
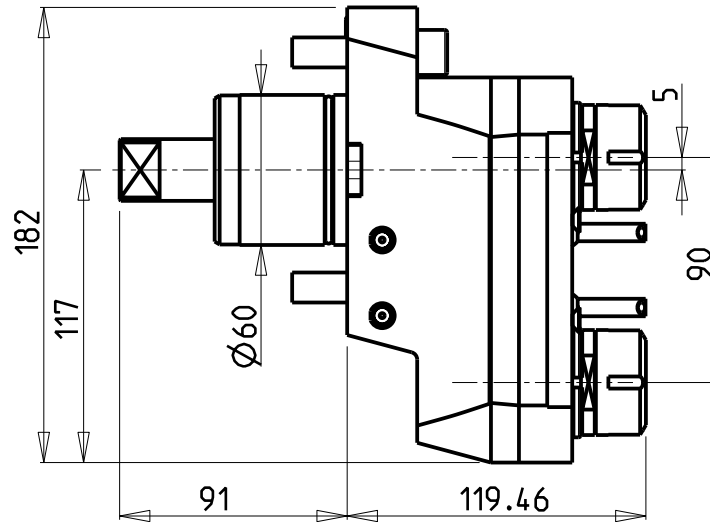
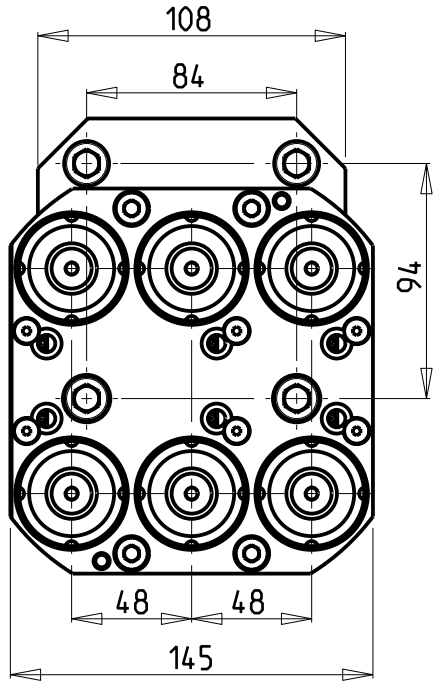

Cod. MT	Mandrino Spindle Spindel	I	RPM	Coppia Max Max Torque Max Drehmoment	N°Utensili N°Tools N°Werkzeuge	Reversibile lato mandrino/contromandrino Reversible sub/main spindle side Umkehrbare Spindelseite/ Gegenspindelseite	Lubrificazione est. Ext. coolant Aussenkuehlung	CHIAVI INCLUSE Keys included Schluesssel inbegriffen
MNL0210625	ER25	1:1	6000	20Nm	6	X	X	MNL0210007 MNL0210008

DMG-MORI

NL1500/2000/2500/3000 12 STAZIONI - NLX1500/2000/2500/3000 12 STAZIONI - NLX4000 - NZL2000/2500 - NZX2500 (BMT60)
NT4200/4250/4300/5400 - CTX2500 (BMT60)

MODULO MOTORIZZATO RADIALE 6 USCITE

Radial 6 head driven tool

Radial angetriebenes Werkzeug 6 Ausgaenge

Subject to change without notice.

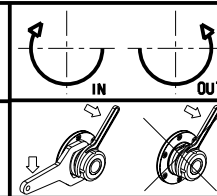

M.T. srl

Via Casino Albini 480
Tel. 0541/956034-957884

Fax 0541/956341

47842 S. GIOVANNI IN M. (RN)

e-mail: mtma@mtmarchetti.com

http://www.mtmarchetti.com



PAGINA MNL110-1-00

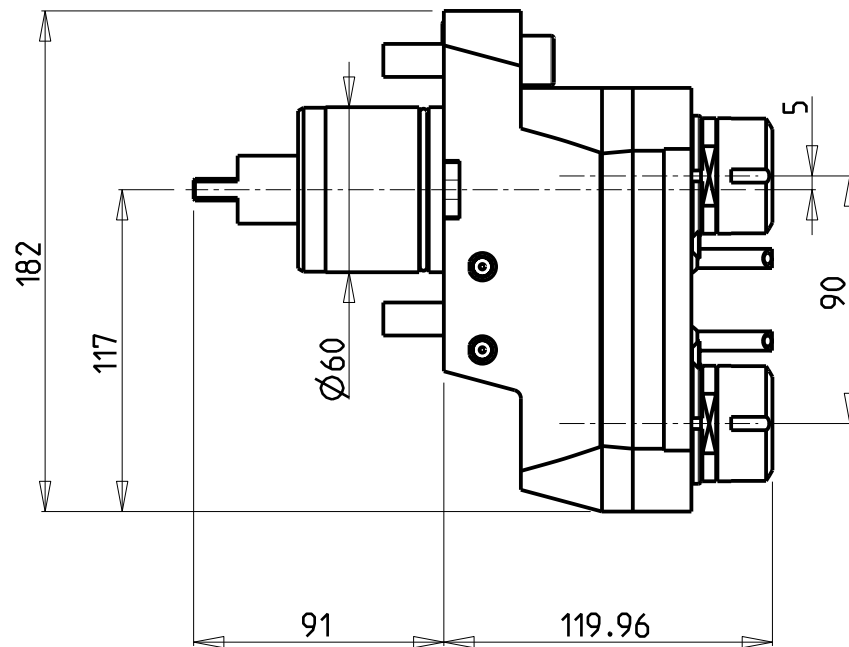
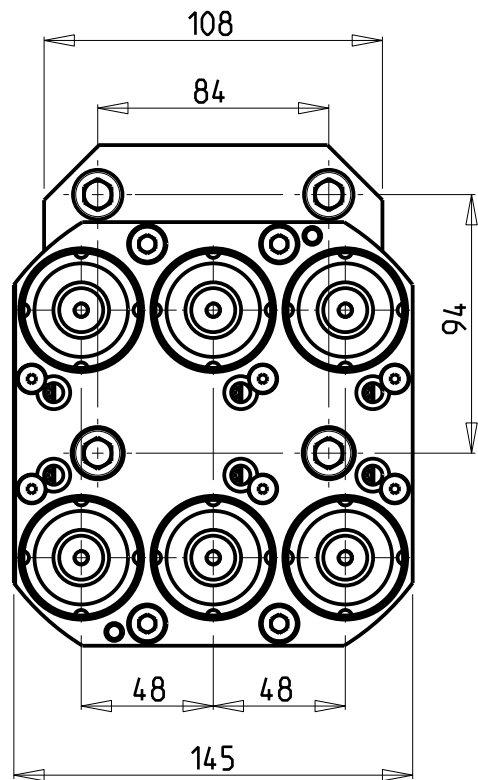

ATTENZIONE - ATTENTION - ACHTUNG

- Per lo smontaggio degli utensili utilizzare sempre la chiave di contrasto come indicato nel manuale d'uso.
- For disassembly of the tools use always the contrast key as mentioned in the user instructions.
- Fuer das Abmontieren der Werkzeuge immer den Gegenschlüssel benutzen wie in der Bedienungsanleitung erwaeht.

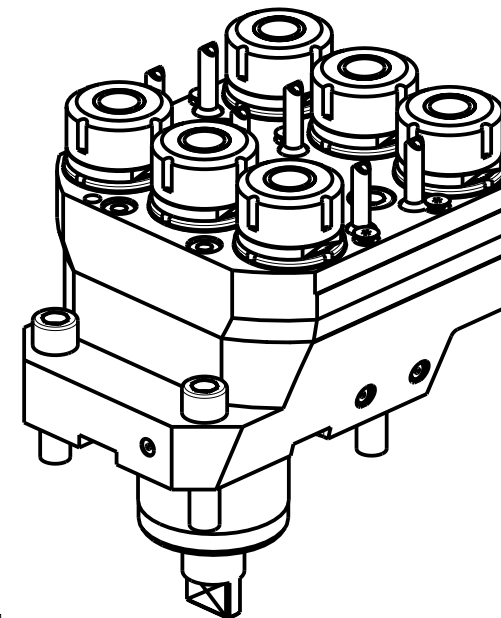

Cod. MT	Mandrino Spindle Spindel	I	RPM	Coppia Max Max Torque Max Drehmoment	N°Utensili N°Tools N°Werkzeuge	Reversibile lato mandrino/contromandrino Reversible sub/main spindle side Umkehrbare Spindel-seite/ Gegenspindel-seite	Lubrificazione est. Ext. coolant Aussenkuehlung	CHIAVI INCLUDE Keys included Schluesssel inbegriffen
MNL1120625	ER25	1:1	10000	20Nm	6	X	X	MNL0210007 MNL0210008

DMG-MORI

NL1500/2000/2500/3000 12 STAZIONI - NLX1500/2000/2500/3000 12 STAZIONI - NLX4000 - NZL2000/2500 - NZX2500 (BMT60)
NT4200/4250/4300/5400 - CTX2500 (BMT60)

MODULO MOTORIZZATO RADIALE 6 USCITE 10000 RPM

Radial 6 head driven tool 10000 rpm

Radial angetriebenes Werkzeug 6 Ausgaenge 10000 rpm

Subject to change without notice.

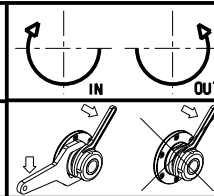

M.T. srl

Via Casino Albini 480
Tel. 0541/956034-957884
Fax 0541/956341

47842 S. GIOVANNI IN M. (RN)
e-mail: mtma@mtmarchetti.com
http://www.mtmarchetti.com



PAGINA MNL110-1-01

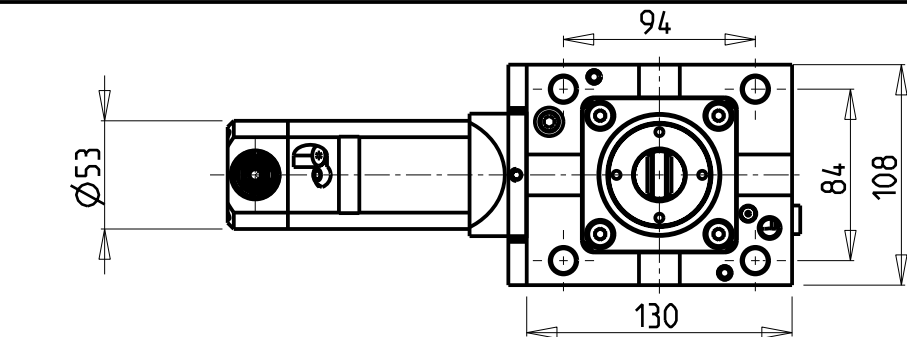

PER LAVORAZIONI INTERNE
SU FORI Ø60 MINIMO

For machining internal
holes with Ø60 min. hole

Fuer interne Bearbeitungen
am Loch minimum Ø60

ATTENZIONE - ATTENTION - ACHTUNG

- Per lo smontaggio degli utensili utilizzare sempre la chiave di contrasto come indicato nel manuale d'uso.
- For disassembly of the tools use always the contrast key as mentioned in the user instructions.
- Fuer das Abmontieren der Werkzeuge immer den Gegenschlüssel benutzen wie in der Bedienungsanleitung erwaeht.

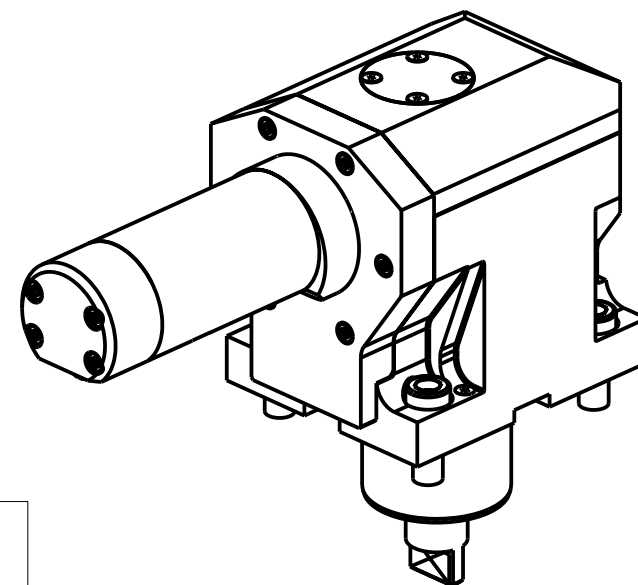
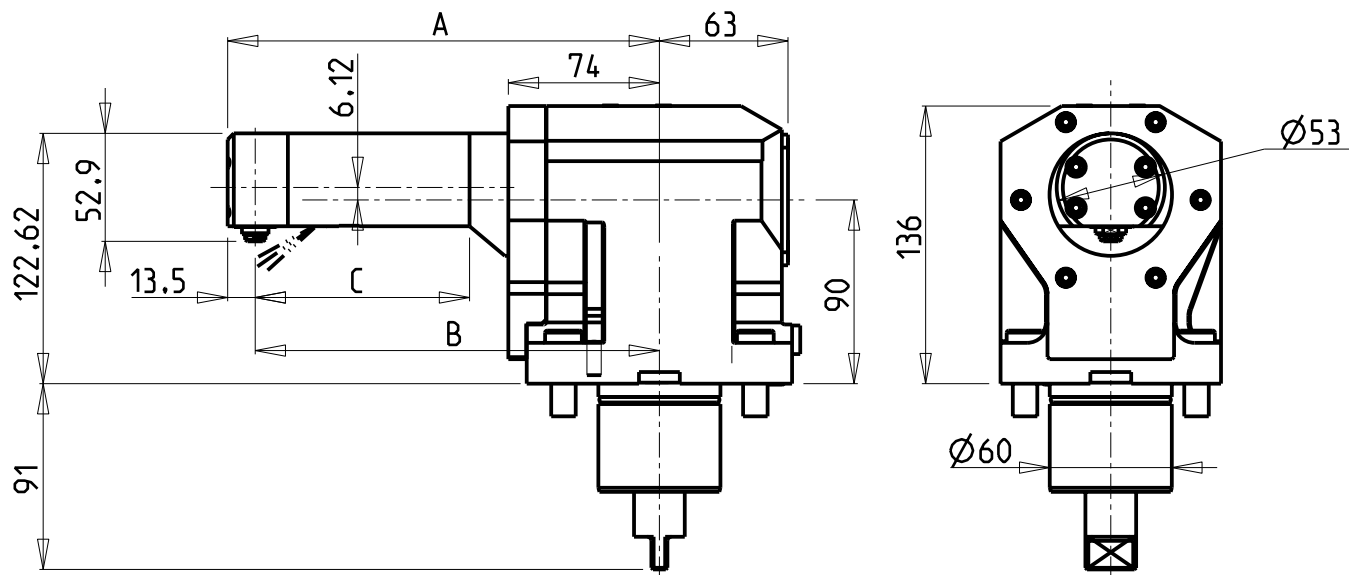

Cod. MT	Mandrino Spindle Spindel	I	RPM	Coppia Max Max Torque Max Drehmoment	Lubrificazione est. Ext. coolant Aussenkuehlung	A	B	C	CHIAVI INCLUSE Keys included Schluessel einbegriffen	
MNL0961055	CHG	1:1	6000	8Nm	X	161.5	148	55	CHUB13	CHCHG10
MNL0961105	CHG	1:1	6000	8Nm	X	211.5	198	105	CHUB13	CHCHG10
MNL0961155	CHG	1:1	6000	8Nm	X	261.5	248	155	CHUB13	CHCHG10

DMG-MORI

NL1500/2000/2500/3000 12 STAZIONI - NLX1500/2000/2500/3000 12 STAZIONI - NLX4000 - NZL2000/2500 - NZX2500 (BMT60)
NT4200/4250/4300/5400 - NTX2000/2500/3000 2ND GEN. 10ST. - CTX2500 (BMT60)

MODULO MOTORIZZATO RADIALE ROVESCIAIO DISASSATO IN Z

Radial inverted driven tool re-directed in Z

Radial angetriebenes Werkzeug umgedreht achsversetzt in Z

Subject to change without notice.

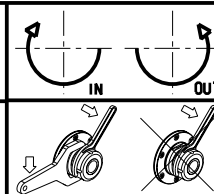

M.T. srl

Via Casino Albini 480
Tel. 0541/956034-957884
Fax 0541/956341

47842 S. GIOVANNI IN M. (RN)
e-mail: mtma@mtmarchetti.com
http://www.mtmarchetti.com



PAGINA MNL120-1-30

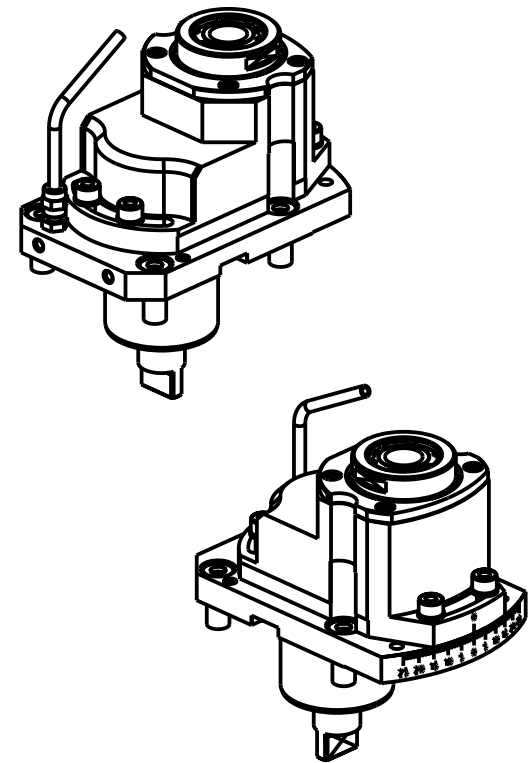
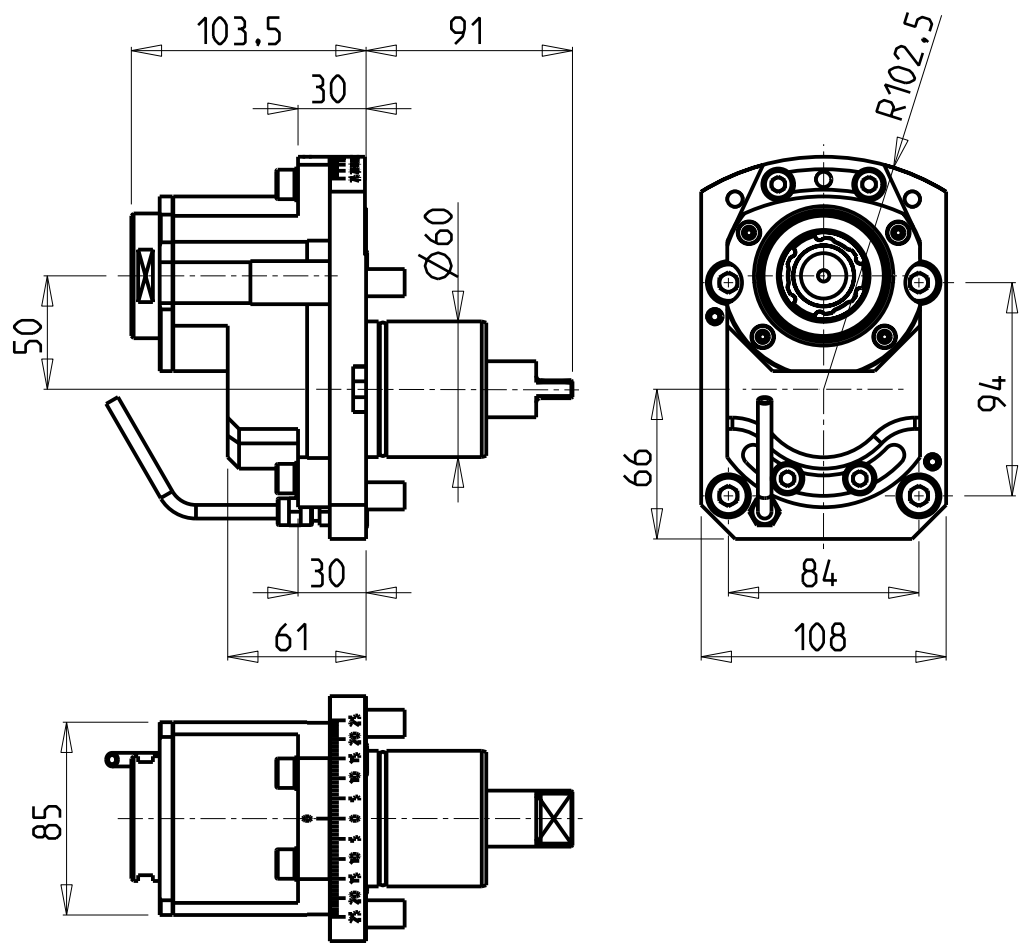

ATTENZIONE - ATTENTION - ACHTUNG

- Per lo smontaggio degli utensili utilizzare sempre la chiave di contrasto come indicato nel manuale d'uso.
- For disassembly of the tools use always the contrast key as mentioned in the user instructions.
- Fuer das Abmontieren der Werkzeuge immer den Gegenschlüssel benutzen wie in der Bedienungsanleitung erwaeht.

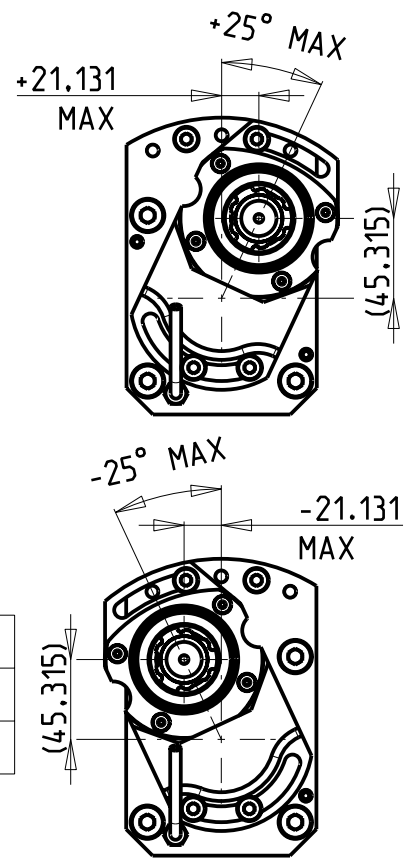

- Chiave inclusa
- Key included
- Schlüssel inbegriffen

Cod. MT	Mandrino Spindle Spindel	I	RPM	Coppia Max Max Torque Max Drehmoment	Reversibile lato mandrino/contromandrino Reversible sub/main spindle side Umkehrbare Spindelseite/ Gegenspindelseite	Lubrificazione est. Ext. coolant Aussenkuehlung	CHIAVI NON INCLUSE Keys not included Schluessel nicht einbegriffen		
MNL0950332	ERA32	1:1	6000	100Nm	X	X	CHUB30	CHUB50	CHTAER32ZC *

DMG-MORI
 NL1500/2000/2500/3000 12 STAZIONI - NLX1500/2000/2500/3000 12 STAZIONI - NLX4000 - NZL2000/2500 - NZX2500 (BMT60)
 NT4200/4250/4300/5400 - NTX2000/2500/3000 2ND GEN. 10ST. - CTX2500 (BMT60)

MODULO MOTORIZZATO RADIALE DISASSATO 50mm ORIENTABILE ±25°
 Radial ±25° adjustable angle driven tool re-directed by 50mm
 Radial angetriebenes Werkzeug schwenkbar ±25° achsversetzt um 50mm

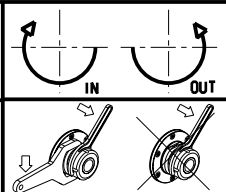

M.T. srl
 Via Casino Albini 480
 Tel. 0541/956034-957884
 Fax 0541/956341
 47842 S. GIOVANNI IN M. (RN)
 e-mail: mtma@mtmarchetti.com
 http://www.mtmarchetti.com



PAGINA MNL135-1-00

Subject to change without notice.

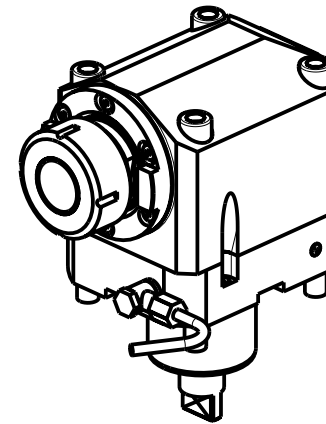
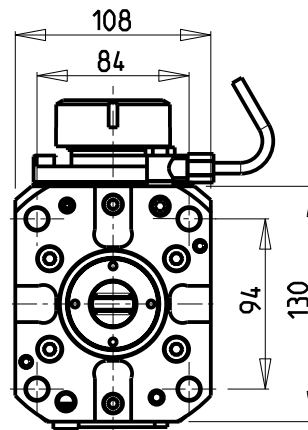
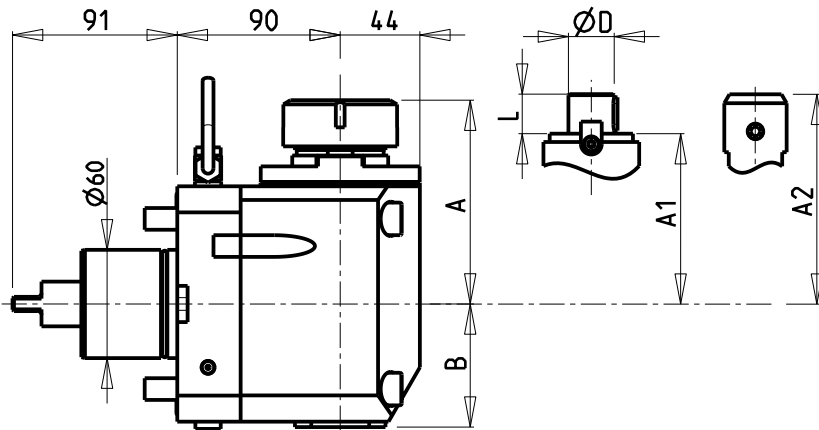

- Chiave inclusa
- Key included
- Schluessel inbegriffen

Cod. MT	Cod. MORI-SEIKI	Mandrino Spindle Spindel	I	RPM	Coppia Max Max Torque Max Drehmoment	Reversibile lato mandrino/contromandrino Reversible sub/main spindle side Umkehrbare Spindel-seite/ Gegenspindel-seite	Lubr.interna Coolant through Innenkuehlung	Lubr.esterna Ext. coolant Aussenkuehlung	A	A1	A2	B	D	L	CHIAVI NON INCLUDE Keys not included Schluessel nicht einbegriffen	
MNL0010525	-	ER25	1:1	6000	100Nm	X	-	X	107.6	-	-	69	-	-	OKU0650004	CHSTER25
MNL0010532	T32207	ER32	1:1	6000	100Nm	X	-	X	110.6	-	-	69	-	-	OKU0650004	CHSTER32
MNL0010140	T32214	ER40	1:1	6000	100Nm	X	-	X	112.6	-	-	69	-	-	OKU0650004	CHSTER40
MNL0010332	-	ER A 32	1:1	6000	100Nm	X	-	X	98.5	-	-	69	-	-	OKU0650004	CHUB32
MNL0011525	-	ER25	1:1	6000	100Nm	X	P=70bar	X	107.6	-	-	79	-	-	OKU0650004	CHSTER25
MNL0011532	-	ER32	1:1	6000	100Nm	X	P=70bar	X	110.6	-	-	79	-	-	OKU0650004	CHSTER32
MNL0011140	-	ER40	1:1	6000	100Nm	X	P=70bar	X	112.6	-	-	79	-	-	OKU0650004	CHSTER40
MNL0010432	-	ER A 32	1:1	6000	100Nm	X	P=70bar	X	98.5	-	-	79	-	-	OKU0650004	CHUB32
MNL0011617	-	Ø16x17	1:1	6000	100Nm	X	-	X	-	87.5	-	69	16	17	OKU0650004	CH_VTCROCE_M08
MNL0012219	-	Ø22x19	1:1	6000	100Nm	X	-	X	-	87.5	-	69	22	19	OKU0650004	CH_VTCROCE_M10
MNL0012721	-	Ø27x21	1:1	6000	100Nm	X	-	X	-	87.5	-	69	27	21	OKU0650004	CH_VTCROCE_M12
MNL0012519	-	Ø1"x19	1:1	6000	100Nm	X	-	X	-	87.5	-	69	1"	19	OKU0650004	CH_VTCROCE_M12
MNL0010120	-	WELDON 20	1:1	6000	100Nm	X	-	X	-	-	105.5	69	-	-	-	-
MNL0010125	-	WELDON 25	1:1	6000	100Nm	X	-	X	-	-	115	69	-	-	-	-
MNL0010132	-	WELDON 32	1:1	6000	100Nm	X	-	X	-	-	131.5	69	-	-	-	-
MNL0010220	-	WELDON 20	1:1	6000	100Nm	X	P=70bar	X	-	-	105.5	91.5	-	-	-	-
MNL0010225	-	WELDON 25	1:1	6000	100Nm	X	P=70bar	X	-	-	115	91.5	-	-	-	-

DMG-MORI
 NL1500/2000/2500/3000 12 STAZIONI - NLX1500/2000/2500/3000 12 STAZIONI - NLX4000 - NZL2000/2500 - NZX2500 (BMT60)
 NT4200/4250/4300/5400 - NTX2000/2500/3000 2ND GEN. 10ST. - CTX2500 (BMT60)

MODULO MOTORIZZATO ASSIALE
 Axial driven tool
 Axial angetriebenes Werkzeug

Subject to change without notice.

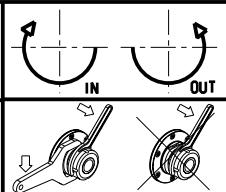

M.T. srl
 Via Casino Albini 480
 Tel. 0541/956034-957884
 Fax 0541/956341
 47842 S. GIOVANNI IN M. (RN)
 e-mail: mtma@mtmarchetti.com
 http://www.mtmarchetti.com



PAGINA MNL150-1-10

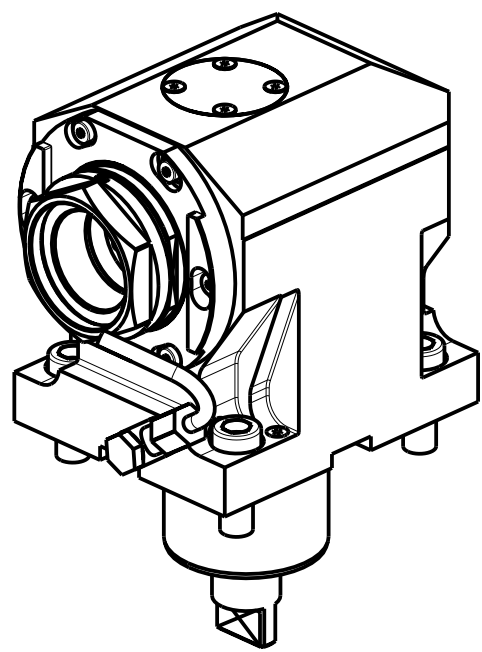
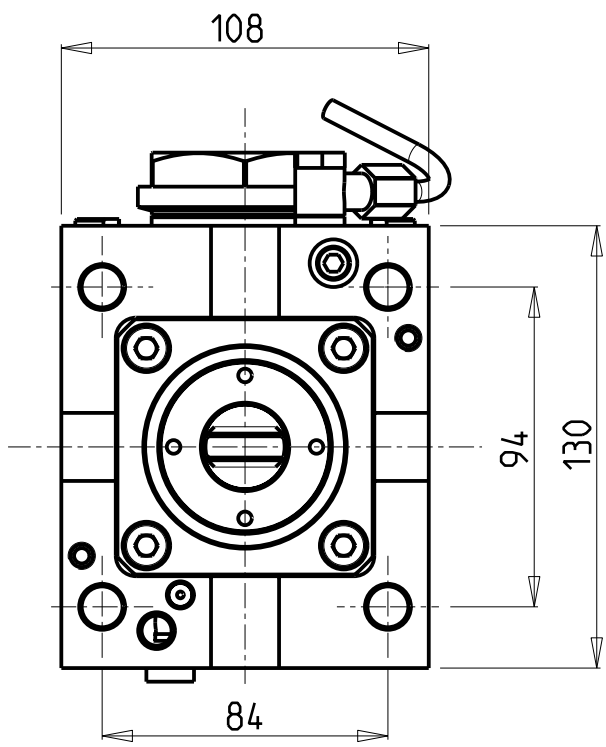
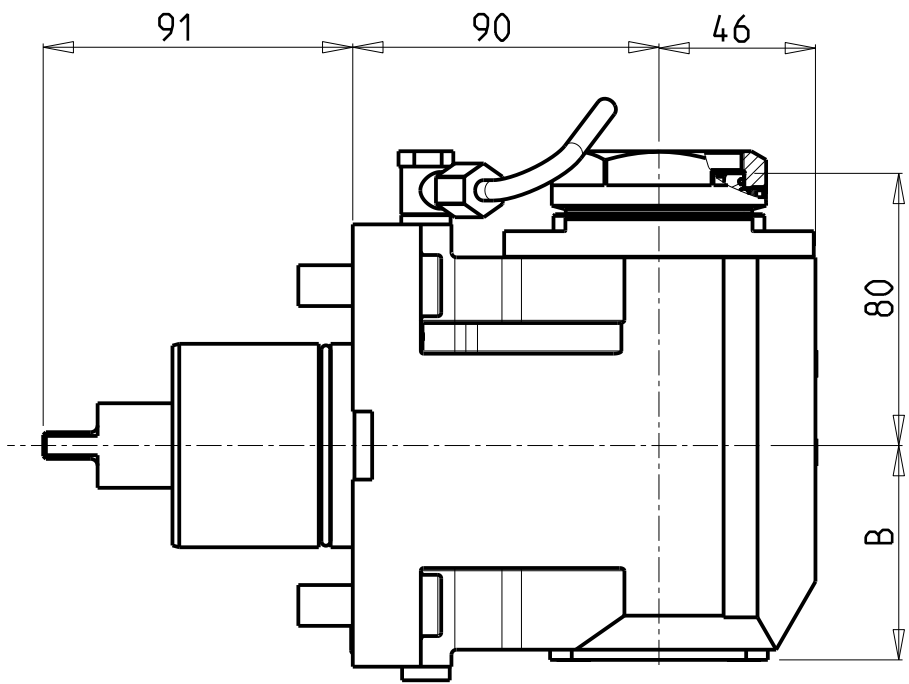

PER PORTAUTENSILI MODULARI MTSK-40 VEDI PAG. TBL300-1-40 E PER MTSK-50 VEDI PAG. TBL300-1-50
 FOR MTSK-40 QUICK CHANGE TOOLHOLDERS CLAMPINGS SEE PAGE TBL300-1-40 AND FOR MTSK-50 SEE PAGE TBL300-1-50
 FUER MTSK-40 MODULARE WERKZEUGAUFNAHMEN SIEHE SEITE TBL300-1-40 UND FUER MTSK-50 SIEHE SEITE TBL300-1-50

Cod. MT	Mandrino Spindel Spindel	I	RPM	Coppia Max Max Torque Max Drehmoment	Reversibile lato mandrino/contromandrino Reversible sub/main spindle side Umkehrbare Spindel-seite/ Gegenspindel-seite	Lubr.interna Coolant through Innenkuehlung	Lubr.esterna Ext. coolant Aussenkuehlung	B	CHIAVI NON INCLUSE Keys not included Schluessel nicht einbegriffen	
MNL0580140	MTSK-40	1:1	6000	100Nm	X	-	X	63	CHUB46	OKU0430007 *
MNL0580240	MTSK-40	1:1	6000	100Nm	X	P=70bar	X	75.5	CHUB46	OKU0430007 *
MNL0580150	MTSK-50	1:1	6000	100Nm	X	-	X	63	CHUB55	OKU0430007 *
MNL0580250	MTSK-50	1:1	6000	100Nm	X	P=70bar	X	75.5	CHUB55	OKU0430007 *

- Chiave inclusa
- Key included
- Schluessel inbegriffen

DMG-MORI
 NL1500/2000/2500/3000 12 STAZIONI - NLX1500/2000/2500/3000 12 STAZIONI - NLX4000 - NZL2000/2500 - NZX2500 (BMT60)
 NT4200/4250/4300/5400 - NTX2000/2500/3000 2ND GEN. 10ST. - CTX2500 (BMT60)

MODULO MOTORIZZATO ASSIALE MTSK
 Axial MTSK driven tool
 Axial MTSK angetriebenes Werkzeug

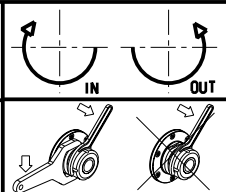

M.T. srl
 Via Casino Albini 480
 Tel. 0541/956034-957884
 Fax 0541/956341
 47842 S. GIOVANNI IN M. (RN)
 e-mail: mtma@tmarchetti.com
 http://www.mtmarchetti.com



PAGINA MNL150-1-10-K

Subject to change without notice.

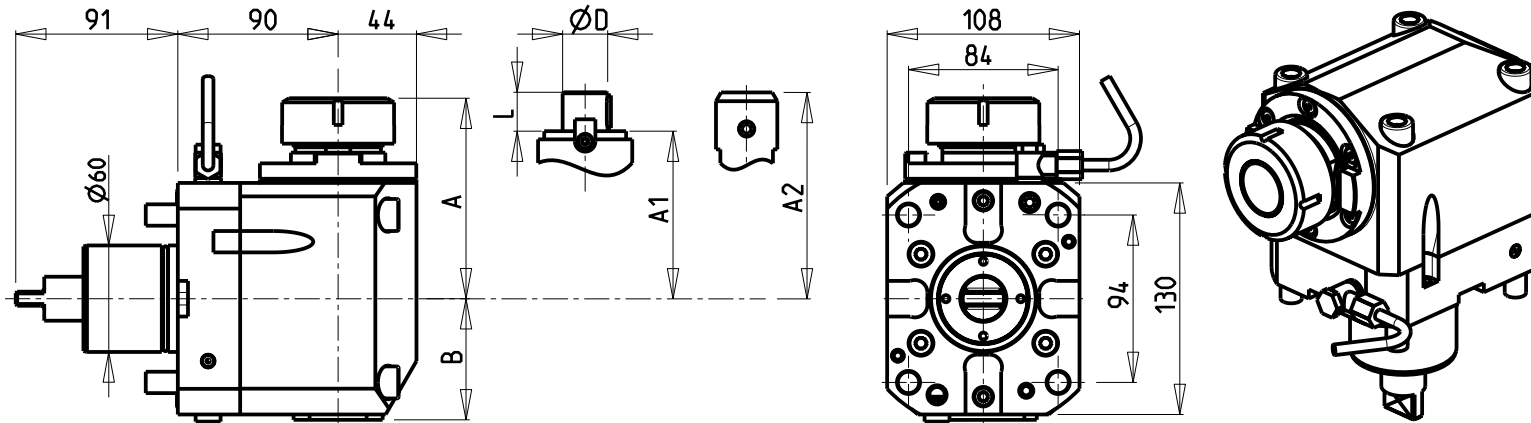

- Chiave inclusa
- Key included
- Schlüssel inbegriffen

Cod. MT	Mandrino Spindle Spindel	I	RPM	Coppia Max Max Torque Max Drehmoment	Reversibile lato mandrino/contromandrino Reversible sub/main spindle side Umkehrbare Spindel-seite/ Gegenspindel-seite	Lubr.interna Coolant through Innenkuehlung	Lubr.esterna Ext. coolant Aussenkuehlung	A	A1	A2	B	D	L	CHIAVI NON INCLUDE Keys not included Schlüssel nicht inbegriffen
MNL0750525	ER25	1:1	10000	100Nm	X	-	X	107.6	-	-	69	-	-	OKU0650004 ■ CHSTER25
MNL0750532	ER32	1:1	10000	100Nm	X	-	X	110.6	-	-	69	-	-	OKU0650004 ■ CHSTER32
MNL0750140	ER40	1:1	10000	100Nm	X	-	X	112.6	-	-	69	-	-	OKU0650004 ■ CHSTER40
MNL0750332	ER A 32	1:1	10000	100Nm	X	-	X	98.5	-	-	69	-	-	OKU0650004 ■ CHUB32
MNL0751525	ER25	1:1	10000	100Nm	X	P=70bar	X	107.6	-	-	79	-	-	OKU0650004 ■ CHSTER25
MNL0751532	ER32	1:1	10000	100Nm	X	P=70bar	X	110.6	-	-	79	-	-	OKU0650004 ■ CHSTER32
MNL0751140	ER40	1:1	10000	100Nm	X	P=70bar	X	112.6	-	-	79	-	-	OKU0650004 ■ CHSTER40
MNL0750432	ER A 32	1:1	10000	100Nm	X	P=70bar	X	98.5	-	-	79	-	-	OKU0650004 ■ CHUB32
MNL0751617	Ø16x17	1:1	10000	100Nm	X	-	X	-	87.5	-	69	16	17	OKU0650004 ■ CH_VTCROCE_M08 ■
MNL0752219	Ø22x19	1:1	10000	100Nm	X	-	X	-	87.5	-	69	22	19	OKU0650004 ■ CH_VTCROCE_M10 ■
MNL0752721	Ø27x21	1:1	10000	100Nm	X	-	X	-	87.5	-	69	27	21	OKU0650004 ■ CH_VTCROCE_M12 ■
MNL0752519	Ø1"x19	1:1	10000	100Nm	X	-	X	-	87.5	-	69	1"	19	OKU0650004 ■ CH_VTCROCE_M12 ■
MNL0750120	WELDON 20	1:1	10000	100Nm	X	-	X	-	-	105.5	69	-	-	-
MNL0750125	WELDON 25	1:1	10000	100Nm	X	-	X	-	-	115	69	-	-	-
MNL0750132	WELDON 32	1:1	10000	100Nm	X	-	X	-	-	131.5	69	-	-	-
MNL0750220	WELDON 20	1:1	10000	100Nm	X	P=70bar	X	-	-	105.5	91.5	-	-	-
MNL0750225	WELDON 25	1:1	10000	100Nm	X	P=70bar	X	-	-	115	91.5	-	-	-

DMG-MORI

NL1500/2000/2500/3000 12 STAZIONI - NLX1500/2000/2500/3000 12 STAZIONI - NLX4000 - NZL2000/2500 - NZX2500 (BMT60)
 NT4200/4250/4300/5400 - NTX2000/2500/3000 2ND GEN. 10ST. - CTX2500 (BMT60)

MODULO MOTORIZZATO ASSIALE 10000 RPM

Axial driven tool 10000 rpm

Axial angetriebenes Werkzeug 10000 rpm

Subject to change without notice.

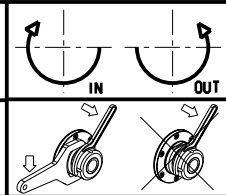

M.T. srl

Via Casino Albini 480
 Tel. 0541/956034-957884

Fax 0541/956341

47842 S. GIOVANNI IN M. (RN)

e-mail: mtma@mtmarchetti.com

http://www.mtmarchetti.com



PAGINA MNL150-1-11

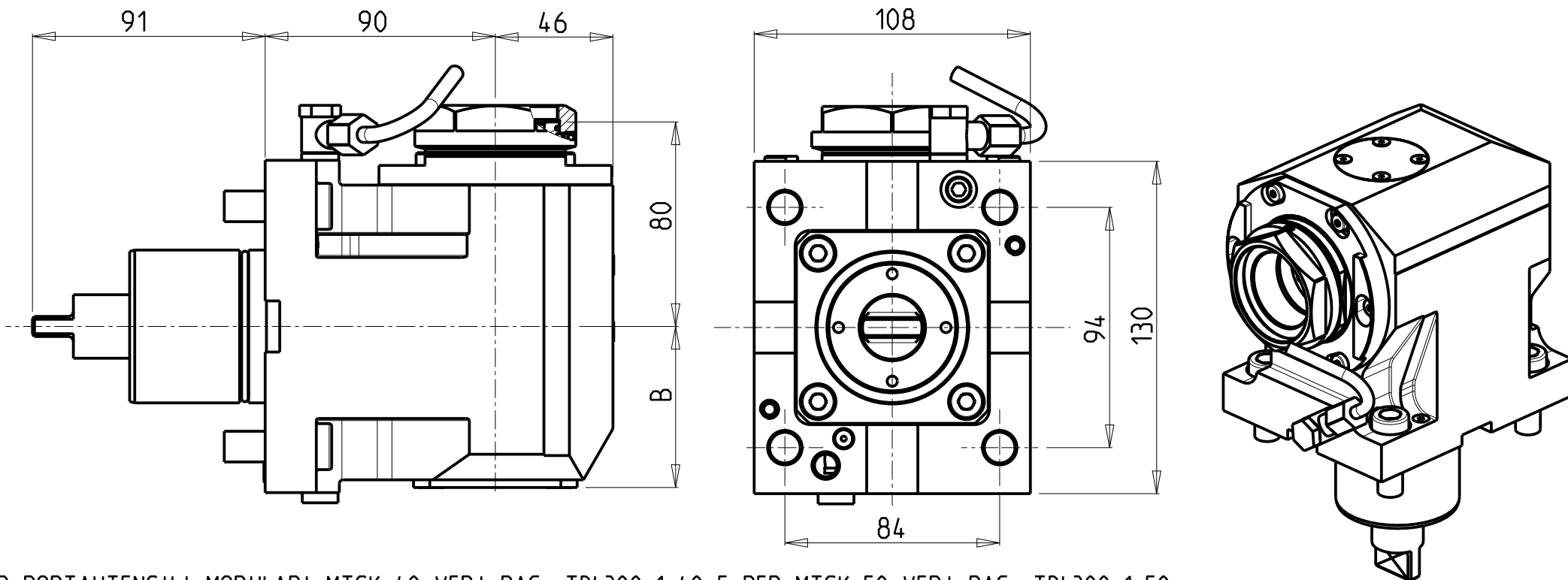

PER PORTAUTENSILI MODULARI MTSK-40 VEDI PAG. TBL300-1-40 E PER MTSK-50 VEDI PAG. TBL300-1-50
 FOR MTSK-40 QUICK CHANGE TOOLHOLDERS CLAMPINGS SEE PAGE TBL300-1-40 AND FOR MTSK-50 SEE PAGE TBL300-1-50
 FUER MTSK-40 MODULARE WERKZEUGAUFNAHMEN SIEHE SEITE TBL300-1-40 UND FUER MTSK-50 SIEHE SEITE TBL300-1-50

Cod. MT	Mandrino Spindle Spindel	I	RPM	Coppia Max Max Torque Max Drehmoment	Reversibile lato mandrino/contromandrino Reversible sub/main spindle side Umkehrbare Spindel-seite/Gegenspindel-seite	Lubr.interna Coolant through Innenkuehlung	Lubr.esterna Ext. coolant Aussenkuehlung	B	CHIAVI NON INCLUSE Keys not included Schluessel nicht einbegriffen	
MNL0780140	MTSK-40	1:1	10000	100Nm	X	-	X	63	CHUB46	OKU0430007 ■
MNL0780240	MTSK-40	1:1	10000	100Nm	X	P=70bar	X	75.5	CHUB46	OKU0430007 ■
MNL0780150	MTSK-50	1:1	10000	100Nm	X	-	X	63	CHUB55	OKU0430007 ■
MNL0780250	MTSK-50	1:1	10000	100Nm	X	P=70bar	X	75.5	CHUB55	OKU0430007 ■

- Chiave inclusa
- Key included
- Schluessel inbegriffen

DMG-MORI

NL1500/2000/2500/3000 12 STAZIONI - NLX1500/2000/2500/3000 12 STAZIONI - NLX4000 - NZL2000/2500 - NZX2500 (BMT60)
 NT4200/4250/4300/5400 - NTX2000/2500/3000 2ND GEN. 10ST. - CTX2500 (BMT60)

MODULO MOTORIZZATO ASSIALE MTSK 10000 RPM

Axial MTSK driven tool 10000 rpm

Axial MTSK angetriebenes Werkzeug 10000 rpm

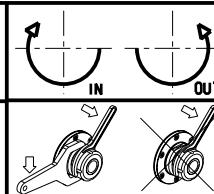

M.T. srl

Via Casino Albini 480
 Tel. 0541/956034-957884
 Fax 0541/956341
 47842 S. GIOVANNI IN M. (RN)
 e-mail: mtma@mtmarchetti.com
 http://www.mtmarchetti.com



PAGINA MNL150-1-11-K

Subject to change without notice.

10/2021

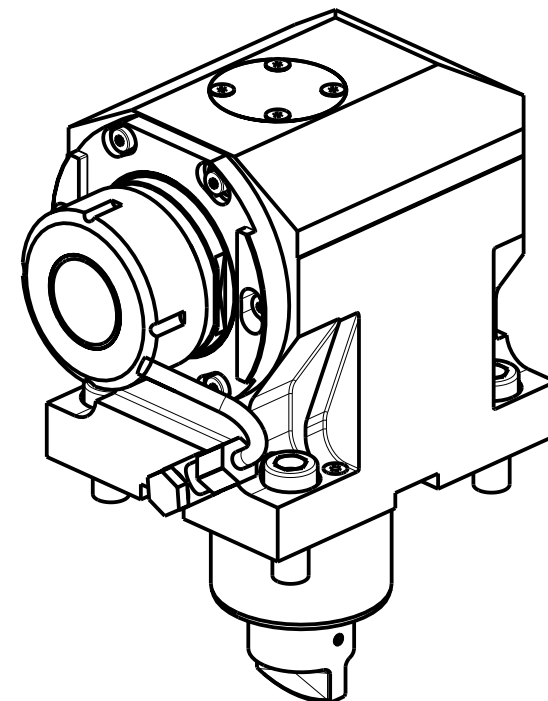
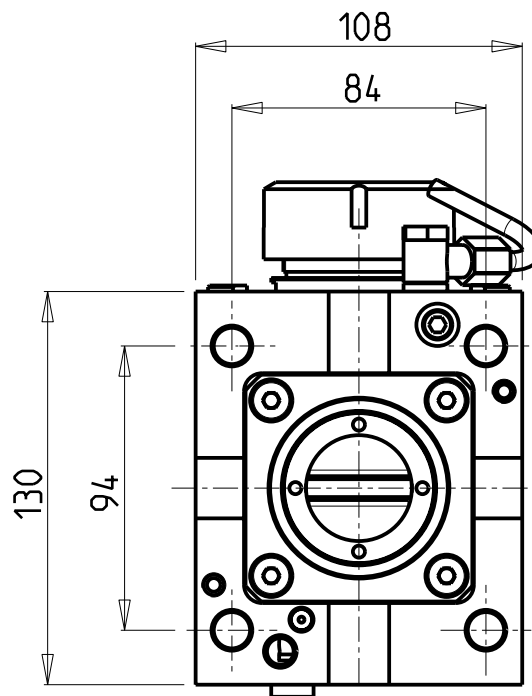
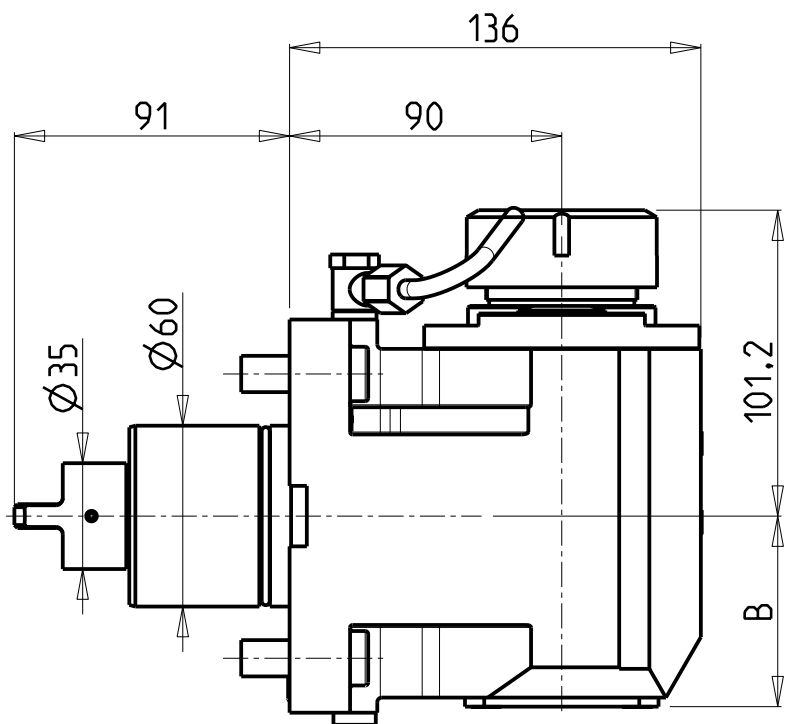

- Chiave inclusa
- Key included
- Schluessel inbegriffen

Cod. MT	Mandrino Spindle Spindel	I	RPM	Coppia Max Max Torque Max Drehmoment	Reversibile lato mandrino/contromandrino Reversible sub/main spindle side Umkehrbare Spindel-seite/ Gegenspindel-seite	Lubr.interna Coolant through Innenkuehlung	Lubr.esterna Ext. coolant Aussenkuehlung	B	CHIAVI NON INCLUSE Keys not included Schluessel nicht einbegriffen	
MNL0840140	ER40	1:1	4000	100Nm	X	-	X	63	CHSTER40	OKU0430007 •
MNL0840240	ER40	1:1	4000	100Nm	X	P=70bar	X	75.5	CHSTER40	OKU0430007 •

DMG-MORI
NLX4000

MODULO MOTORIZZATO ASSIALE
Axial driven tool
Axial angetriebenes Werkzeug

Subject to change without notice.

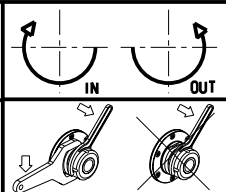

M.T. srl
Via Casino Albini 480
Tel. 0541/956034-957884
Fax 0541/956341
47842 S. GIOVANNI IN M. (RN)
e-mail: mtma@tmarchetti.com
http://www.tmmarchetti.com



PAGINA MNL170-1-10

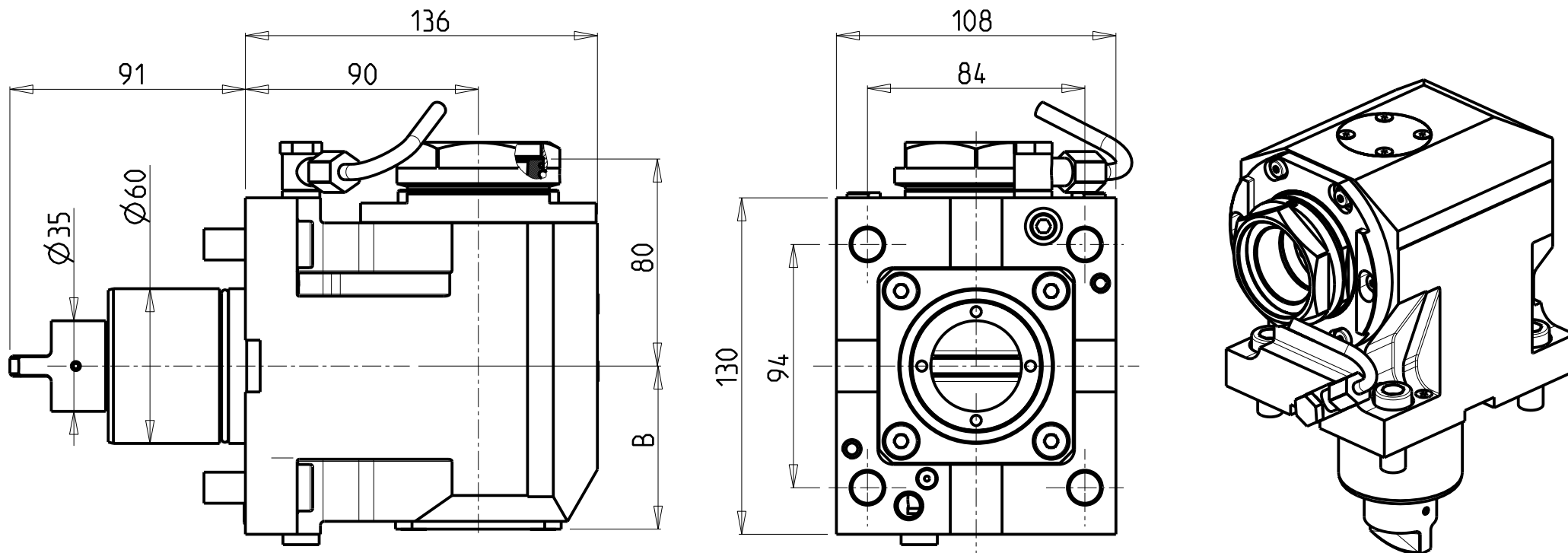

PER PORTAUTENSILI MODULARI MTSK-40 VEDI PAG. TBL300-1-40 E PER MTSK-50 VEDI PAG. TBL300-1-50
 FOR MTSK-40 QUICK CHANGE TOOLHOLDERS CLAMPINGS SEE PAGE TBL300-1-40 AND FOR MTSK-50 SEE PAGE TBL300-1-50
 FUER MTSK-40 MODULARE WERKZEUGAUFNAHMEN SIEHE SEITE TBL300-1-40 UND FUER MTSK-50 SIEHE SEITE TBL300-1-50

Cod. MT	Mandrino Spindle Spindel	I	RPM	Coppia Max Max Torque Max Drehmoment	Reversibile lato mandrino/contromandrino Reversible sub/main spindle side Umkehrbare Spindel-seite/ Gegenspindel-seite	Lubr.interna Coolant through Innenkuehlung	Lubr.esterna Ext. coolant Aussenkuehlung	B	CHIAVI NON INCLUSE Keys not included Schluessel nicht einbegriffen	
MNL0850140	MTSK-40	1:1	4000	100Nm	X	-	X	63	CHUB46	OKU0430007 *
MNL0850240	MTSK-40	1:1	4000	100Nm	X	P=70bar	X	75.5	CHUB46	OKU0430007 *
MNL0850150	MTSK-50	1:1	4000	100Nm	X	-	X	63	CHUB55	OKU0430007 *
MNL0850250	MTSK-50	1:1	4000	100Nm	X	P=70bar	X	75.5	CHUB55	OKU0430007 *

- Chiave inclusa
- Key included
- Schluessel inbegriffen

DMG-MORI
NLX4000

MODULO MOTORIZZATO ASSIALE MTSK
Axial MTSK driven tool
Axial MTSK angetriebenes Werkzeug

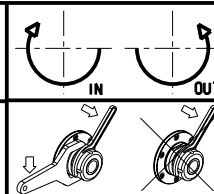

M.T. srl
Via Casino Albini 480
Tel. 0541/956034-957884
Fax 0541/956341
47842 S. GIOVANNI IN M. (RN)
e-mail: mtma@tmarchetti.com
http://www.tmmarchetti.com



PAGINA MNL170-1-10-K

Subject to change without notice.

10/2021

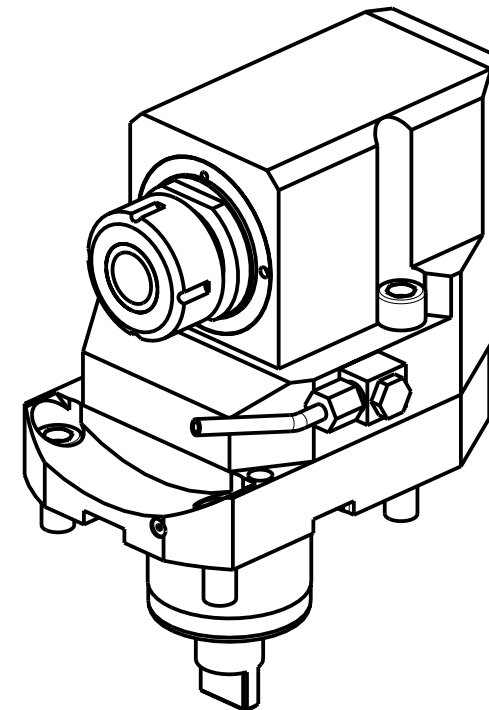
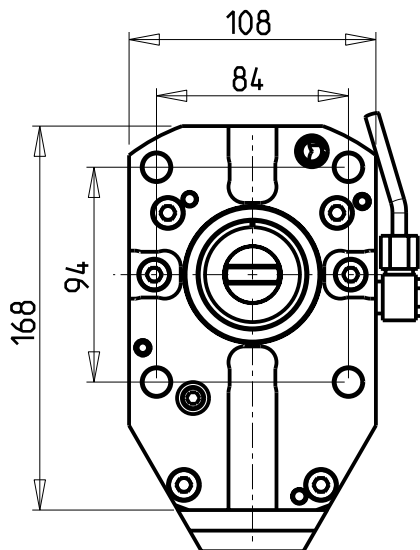
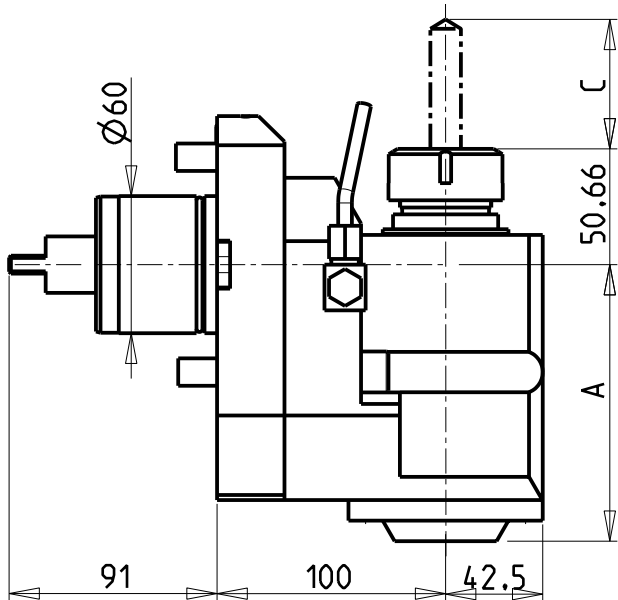
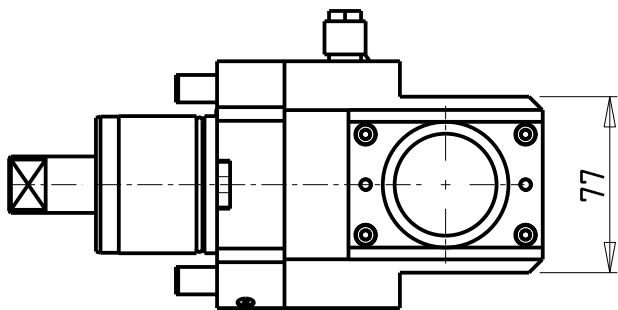

Cod. MT	Mandrino Spindle Spindel	I	RPM	Coppia Max Max Torque Max Drehmoment	Reversibile lato mandrino/contromandrino Reversible sub/main spindle side Umkehrbare Spindel-seite/ Gegenspindel-seite	Lubrificazione int. Coolant through Innenkuehlung	Lubrificazione est. Ext. coolant Aussenkuehlung	A	C max	CHIAVI NON INCLUSE Keys not included Schlüssel nicht einbegriffen	
MNL0290632	ER32	1:1	6000	100Nm	X	-	X	121	118	CHUB46	CHSTER32
MNL0291632	ER32	1:1	6000	100Nm	X	P=70bar	X	135	118	CHUB46	CHSTER32

DMG-MORI

NL1500/2000/2500/3000 12 STAZIONI - NLX1500/2000/2500/3000 12 STAZIONI - NLX4000 - NZL2000/2500 - NZX2500 (BMT60)
 NT4200/4250/4300/5400 - NTX2000/2500/3000 2ND GEN. 10ST. - CTX2500 (BMT60)

MODULO MOTORIZZATO ASSIALE ARRETRATO

Axial rear-set driven tool

Axial angetriebenes Werkzeug zurueckversetzt

Subject to change without notice.

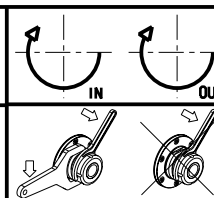

M.T. srl

Via Casino Albini 480
 Tel. 0541/956034-957884
 Fax 0541/956341
 47842 S. GIOVANNI IN M. (RN)
 e-mail: mtma@mtmarchetti.com
 http://www.mtmarchetti.com



PAGINA MNL180-1-10

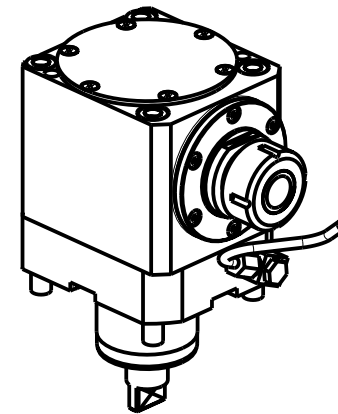
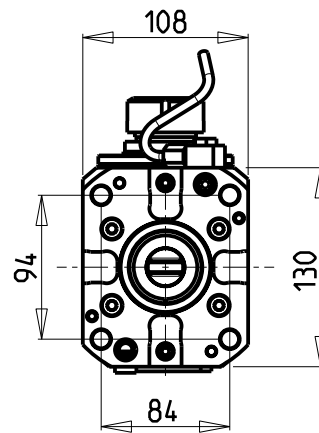
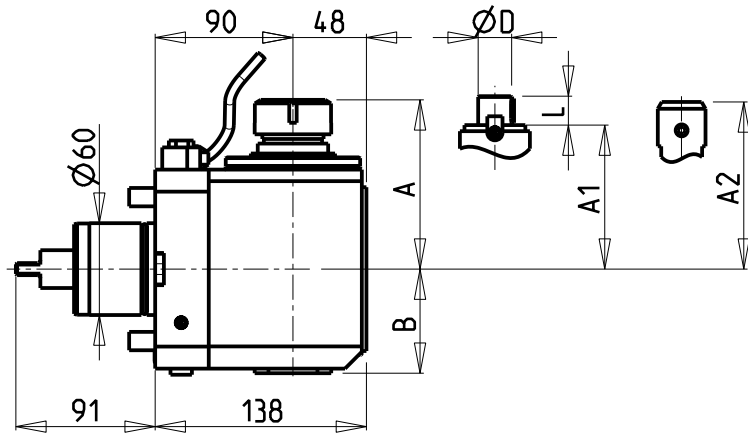

- Chiave inclusa
- Key included
- Schluessel inbegriffen

Cod. MT	Mandrino Spindel Spindel	I	RPM	Coppia Max Max Torque Max Drehmoment	Reversibile lato mandrino/contromandrino Reversible sub/main spindle side Umkehrbare Spindel-seite/ Gegenspindel-seite	Lubrificazione int. Coolant through Innenkühlung	Lubrificazione est. Ext. coolant Aussenkühlung	A	A1	A2	B	D	L	CHIAVI NON INCLUDE Keys not included Schluessel nicht einbegriffen	
MNL0330525	ER25	2:1	3000	100Nm	X	-	X	107.5	-	-	68	-	-	OKU0650004	CHSTER25
MNL0331525	ER25	2:1	3000	100Nm	X	P=70bar	X	107.5	-	-	79	-	-	OKU0650004	CHSTER25
MNL0330532	ER32	2:1	3000	100Nm	X	-	X	110.56	-	-	68	-	-	OKU0650004	CHSTER32
MNL0331532	ER32	2:1	3000	100Nm	X	P=70bar	X	110.56	-	-	79	-	-	OKU0650004	CHSTER32
MNL0330140	ER40	2:1	3000	100Nm	X	-	X	113.16	-	-	68	-	-	OKU0650004	CHSTER40
MNL0331140	ER40	2:1	3000	100Nm	X	P=70bar	X	113.16	-	-	79	-	-	OKU0650004	CHSTER40
MNL0331617	Ø16X17	2:1	3000	100Nm	X	-	X	-	87.5	-	68	16	17	CHUB46	CH_VTCROCE_M08
MNL0332219	Ø22X19	2:1	3000	100Nm	X	-	X	-	87.5	-	68	22	19	CHUB46	CH_VTCROCE_M10
MNL0332721	Ø27x21	2:1	3000	100Nm	X	-	X	-	87.5	-	68	27	21	CHUB46	CH_VTCROCE_M12
MNL0332519	Ø1''X19	2:1	3000	100Nm	X	-	X	-	87.5	-	68	1"	19	CHUB46	CH_VTCROCE_M12
MNL0330120	WELDON 20	2:1	3000	100Nm	X	-	X	-	-	105.5	68	-	-	-	-
MNL0330220	WELDON 20	2:1	3000	100Nm	X	P=70bar	X	-	-	105.5	91.5	-	-	-	-
MNL0330125	WELDON 25	2:1	3000	100Nm	X	-	X	-	-	115	68	-	-	-	-
MNL0330225	WELDON 25	2:1	3000	100Nm	X	P=70bar	X	-	-	115	91.5	-	-	-	-
MNL0330132	WELDON 32	2:1	3000	100Nm	X	-	X	-	-	131.5	68	-	-	-	-
MNL0330232	WELDON 32	2:1	3000	100Nm	X	P=70bar	X	-	-	131.5	91.5	-	-	-	-

DMG-MORI

NL1500/2000/2500/3000 12 STAZIONI - NLX1500/2000/2500/3000 12 STAZIONI - NLX4000 - NZL2000/2500 - NZX2500 (BMT60)
 NT4200/4250/4300/5400 - NTX2000/2500/3000 2ND GEN. 10ST. - CTX2500 (BMT60)

MODULO MOTORIZZATO ASSIALE RIDOTTO I=2:1

Axial geared-down I=2:1 driven tool

Axial angetriebenes Werkzeug untersetzt I=2:1

Subject to change without notice.

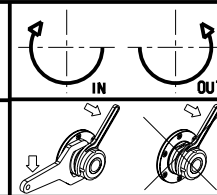

M.T. srl

Via Casino Albini 480
 Tel. 0541/956034-957884
 Fax 0541/956341

47842 S. GIOVANNI IN M. (RN)
 e-mail: mtma@tmarchetti.com
 http://www.tmmarchetti.com



PAGINA MNL190-1-10

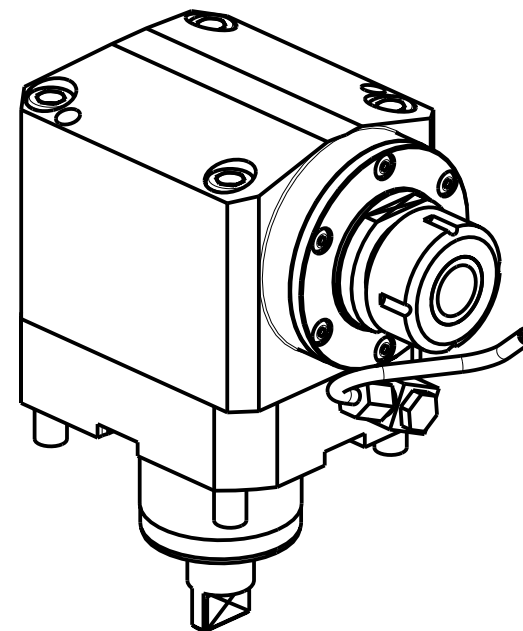
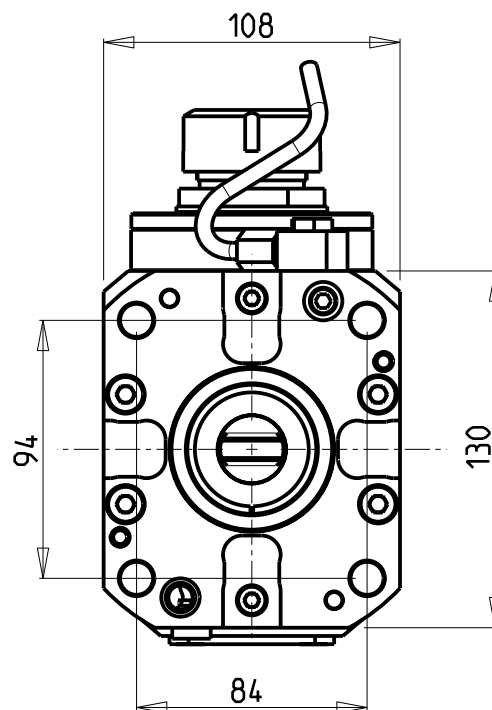
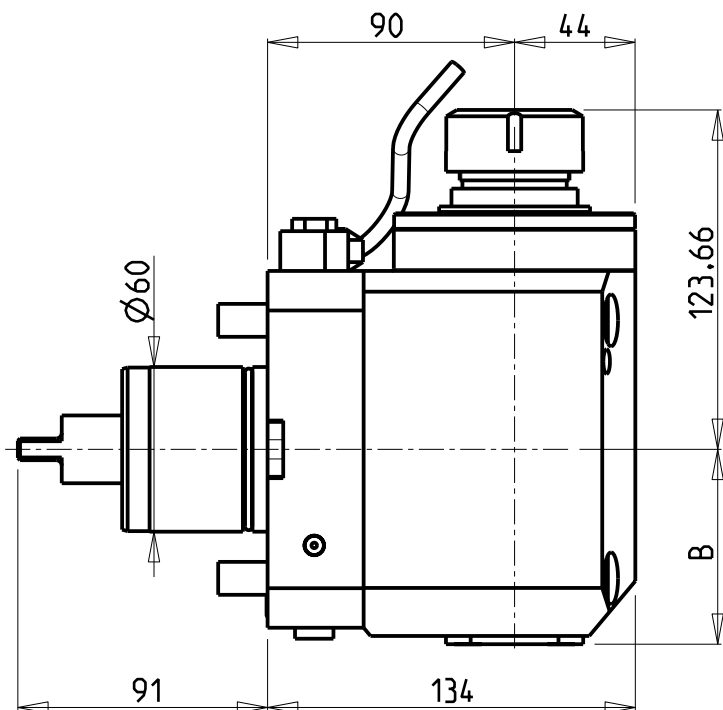

Cod. MT	Mandrino Spindle Spindel	I	RPM	Coppia Max Max Torque Max Drehmoment	Reversibile lato mandrino/contromandrino Reversible sub/main spindle side Umkehrbare Spindel-seite/ Gegenspindel-seite	Lubrificazione int. Coolant through Innenkühlung	Lubrificazione est. Ext. coolant Aussenkühlung	B	CHIAVI NON INCLUSE Keys not included Schlüssel nicht einbegriffen	
MNL0350532	ER32	1:2	12000	50Nm	X	-	X	71	CHUB46	CHSTER32
MNL0351532	ER32	1:2	12000	50Nm	X	P=70bar	X	94.5	CHUB46	CHSTER32

DMG-MORI

NL1500/2000/2500/3000 12 STAZIONI - NLX1500/2000/2500/3000 12 STAZIONI - NLX4000 - NZL2000/2500 - NZX2500 (BMT60)
 NT4200/4250/4300/5400 - NTX2000/2500/3000 2ND GEN. 10ST. - CTX2500 (BMT60)

MODULO MOTORIZZATO ASSIALE MOLTIPLICATO I=1:2

Axial geared-up I=1:2 driven tool

Axial angetriebenes Werkzeug uebersetzt I=1:2

Subject to change without notice.

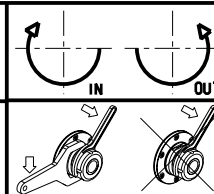

M.T. srl

Via Casino Albini 480
 Tel. 0541/956034-957884

Fax 0541/956341

47842 S. GIOVANNI IN M. (RN)

e-mail: mtma@mtmarchetti.com

http://www.mtmarchetti.com



PAGINA MNL200-1-10

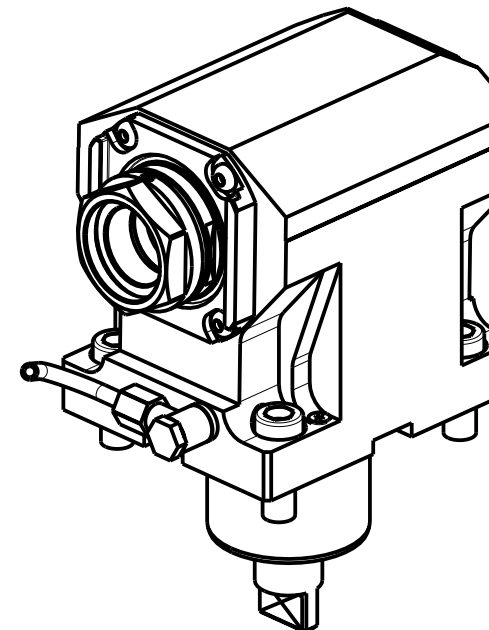
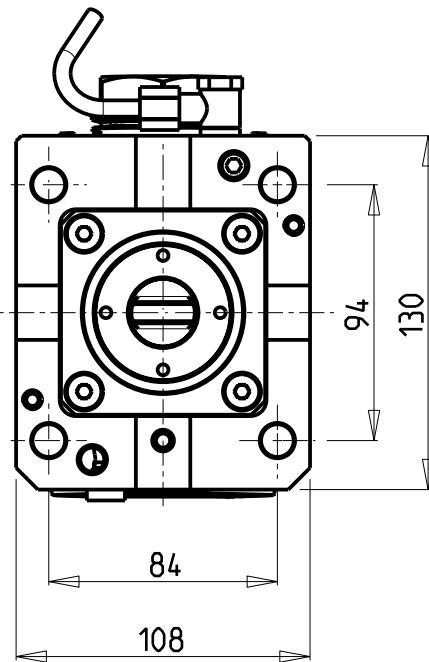
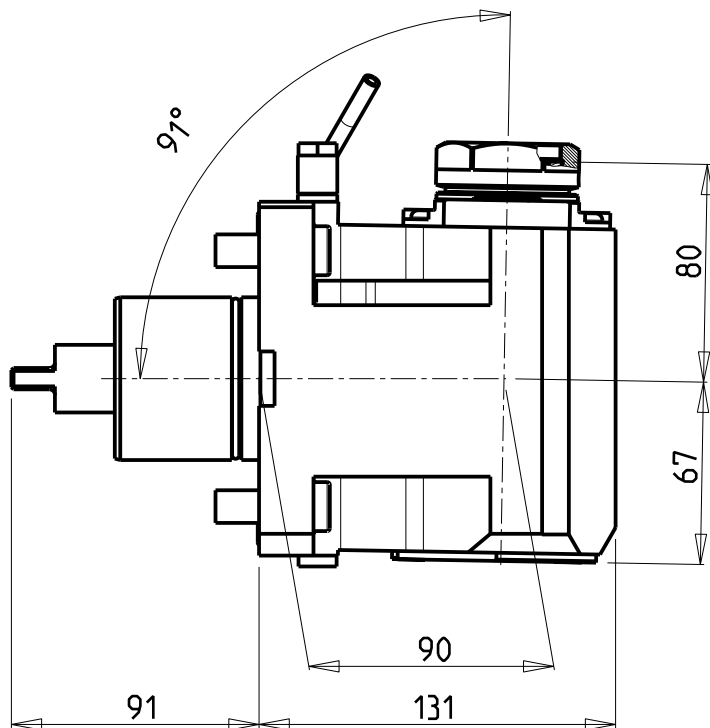

PER PORTAUTENSILI MODULARI MTSK-40 VEDI PAG. TBL300-1-40
 FOR MTSK-40 QUIK CHANGE TOOLHOLDERS CLAMPINGS SEE PAGE TBL300-1-40
 FUER MTSK-40 MODULARE WERKZEUGAUFNAHMEN SIEHE SEITE TBL300-1-40

Cod. MT	Mandrino Spindle Spindel	I	RPM	Coppia Max Max Torque Max Drehmoment	Reversibile lato mandrino/contromandrino Reversible sub/main spindle side Umkehrbare Spindel-seite/ Gegenspindel-seite	Lubr.esterna Ext. coolant Aussenkuehlung	CHIAVI NON INCLUSE Keys not included Schlüssel nicht einbegriffen
MNL0900140	MTSK-40	1:1	6000	50Nm	X	X	CHUB46 OKU0650004 *

- Chiave inclusa
- Key included
- Schlüssel inbegriffen

DMG-MORI

NL1500/2000/2500/3000 12 STAZIONI - NLX1500/2000/2500/3000 12 STAZIONI - NLX4000 - NZL2000/2500 - NZX2500 (BMT60)
 NT4200/4250/4300/5400 - NTX2000/2500/3000 2ND GEN. 10ST. - CTX2500 (BMT60)

MODULO MOTORIZZATO ASSIALE MTSK PER POLIGONATURA INTERNA H=90mm

Axial MTSK driven tool for internal polygon-making H=90mm

Axial MTSK angetriebenes Werkzeug fuer interne Facettierung H=90mm

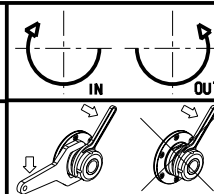

M.T. srl

Via Casino Albini 480
 Tel. 0541/956034-957884
 Fax 0541/956341

47842 S. GIOVANNI IN M. (RN)
 e-mail: mtma@mtmarchetti.com
 http://www.mtmarchetti.com



PAGINA MNL231-1-10-K

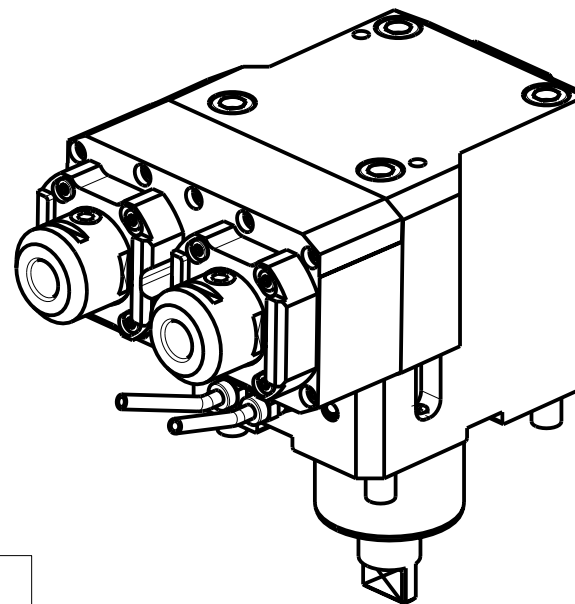
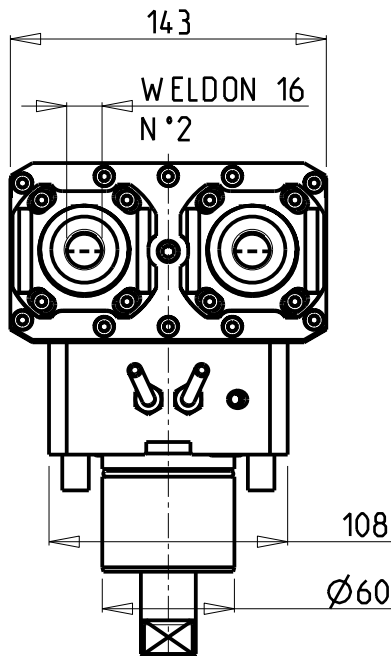
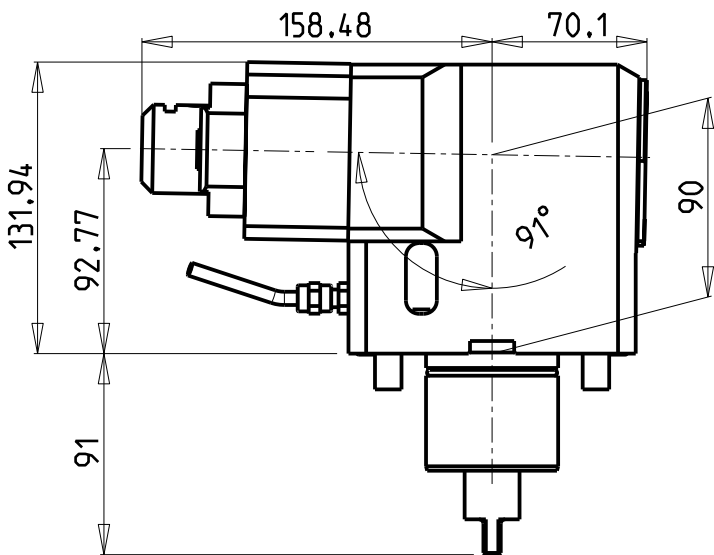
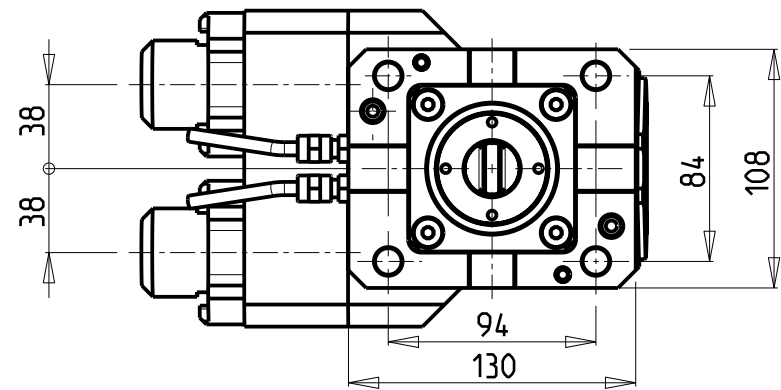

ATTENZIONE - ATTENTION - ACHTUNG

- Per lo smontaggio degli utensili utilizzare sempre la chiave di contrasto come indicato nel manuale d'uso.
- For disassembly of the tools use always the contrast key as mentioned in the user instructions.
- Fuer das Abmontieren der Werkzeuge immer den Gegenschlüssel benutzen wie in der Bedienungsanleitung erwaeht.

Cod. MT	Mandrino Spindle Spindel	I	RPM	Coppia Max Max Torque Max Drehmoment	Reversibile lato mandrino/contromandrino Reversible sub/main spindle side Umkehrbare Spindel-seite/ Gegenspindel-seite	Lubr.esterna Ext. coolant Aussenkuehlung	CHIAVI INCLUDE Keys included Schluessel inbegriffen
MNL0940616	WELDON 16	1:1	6000	50Nm	X	X	SAU0070027

DMG-MORI

NL1500/2000/2500/3000 12 STAZIONI - NLX1500/2000/2500/3000 12 STAZIONI - NLX4000 - NZL2000/2500 - NZX2500 (BMT60)
 NT4200/4250/4300/5400 - NTX2000/2500/3000 2ND GEN. 10ST. - CTX2500 (BMT60)

MODULO MOTORIZZATO ASSIALE 2 USCITE IN Y PER POLIGONATURA INTERNA H=90mm
 Axial Single side twin head driven tool in Y for internal polygon-making H=90mm
 Axial angetriebenes Werkzeug 2 Ausgaenge in Y fuer interne Facettierung H=90mm

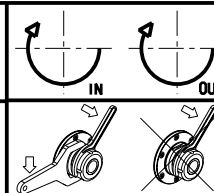

M.T. srl

Via Casino Albini 480
 Tel. 0541/956034-957884
 Fax 0541/956341

47842 S. GIOVANNI IN M. (RN)
 e-mail: mtma@mtmarchetti.com
 http://www.mtmarchetti.com



PAGINA MNL233-1-10

Subject to change without notice.

10/2021

ATTENZIONE - ATTENTION - ACHTUNG

- Per lo smontaggio degli utensili utilizzare sempre la chiave di contrasto come indicato nel manuale d'uso.
- For disassembly of the tools use always the contrast key as mentioned in the user instructions.
- Fuer das Abmontieren der Werkzeuge immer den Gegenschlüssel benutzen wie in der Bedienungsanleitung erwaeht.

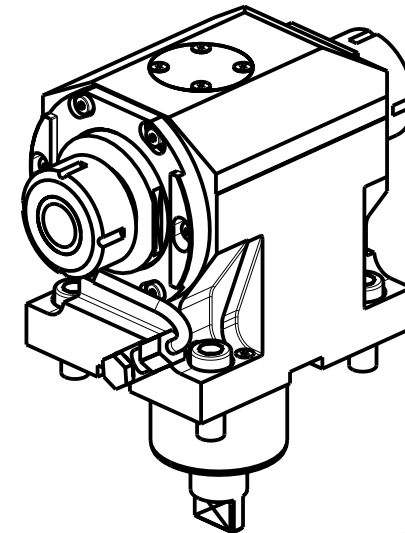
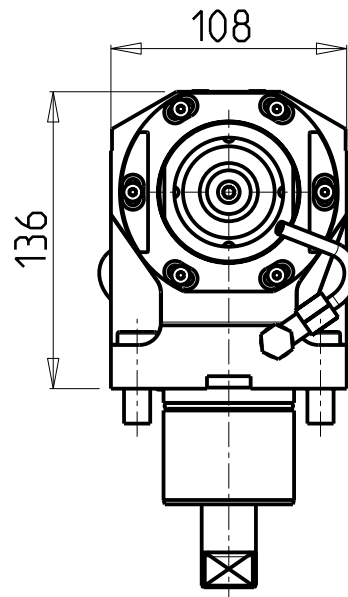
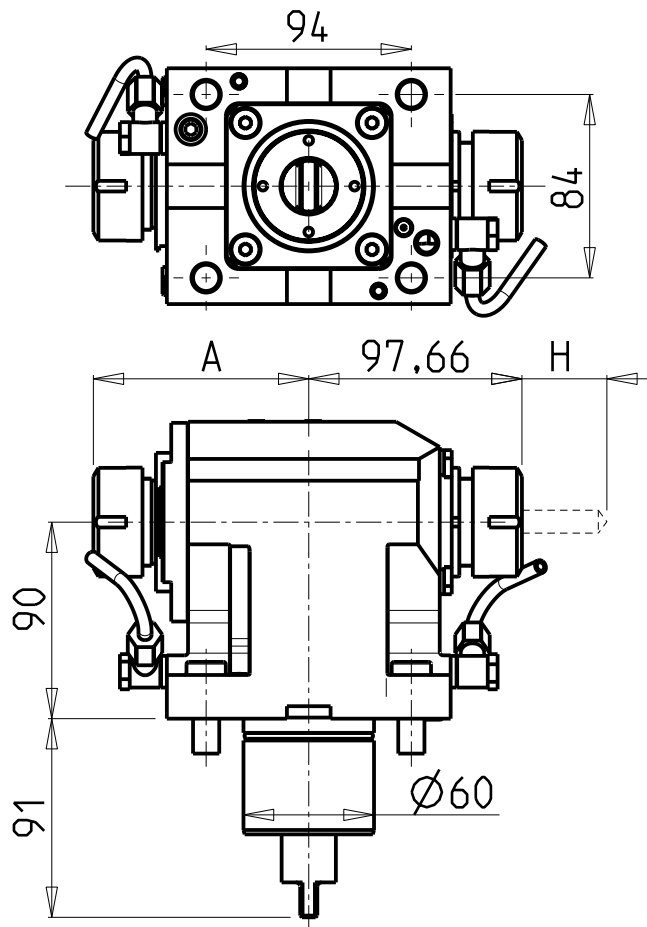

- Chiave inclusa
- Key included
- Schlüssel inbegriffen

Cod. MT	Mandrino Spindle Spindel	I	RPM	Coppia Max Max Torque Max Drehmoment	Reversibile lato mandrino/contromandrino Reversible sub/main spindle side Umkehrbare Spindel-seite/ Gegenspindel-seite	Lubr.esterna Ext. coolant Aussenkuehlung	A	H Max Lato contromand. Subspindle side Gegenspindel-seite	CHIAVI NON INCLUSE Keys not included Schluessel nicht einbegriffen
MNL0830232	ER32+ER32	1:1	6000	100Nm	X	X	98.7	74	OKU0430007 • CHSTER32 -
MNL0830240	ER40+ER32	1:1	6000	100Nm	X	X	101.7	74	OKU0430007 • CHSTER32 CHSTER40

DMG-MORI
 NL1500/2000/2500/3000 12 STAZIONI - NLX1500/2000/2500/3000 12 STAZIONI - NLX4000 - NZL2000/2500 - NZX2500 (BMT60)
 NT4200/4250/4300/5400 - CTX2500 (BMT60)

MODULO MOTORIZZATO ASSIALE BISPORGENTE
 Axial opposite face twin driven tool
 Axial angetriebenes Werkzeug halb vorspringend

Subject to change without notice.

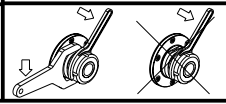

M.T. srl
 Via Casino Albini 480
 Tel. 0541/956034-957884
 Fax 0541/956341
 47842 S. GIOVANNI IN M. (RN)
 e-mail: mtma@mtmarchetti.com
 http://www.mtmarchetti.com



PAGINA MNL240-1-10

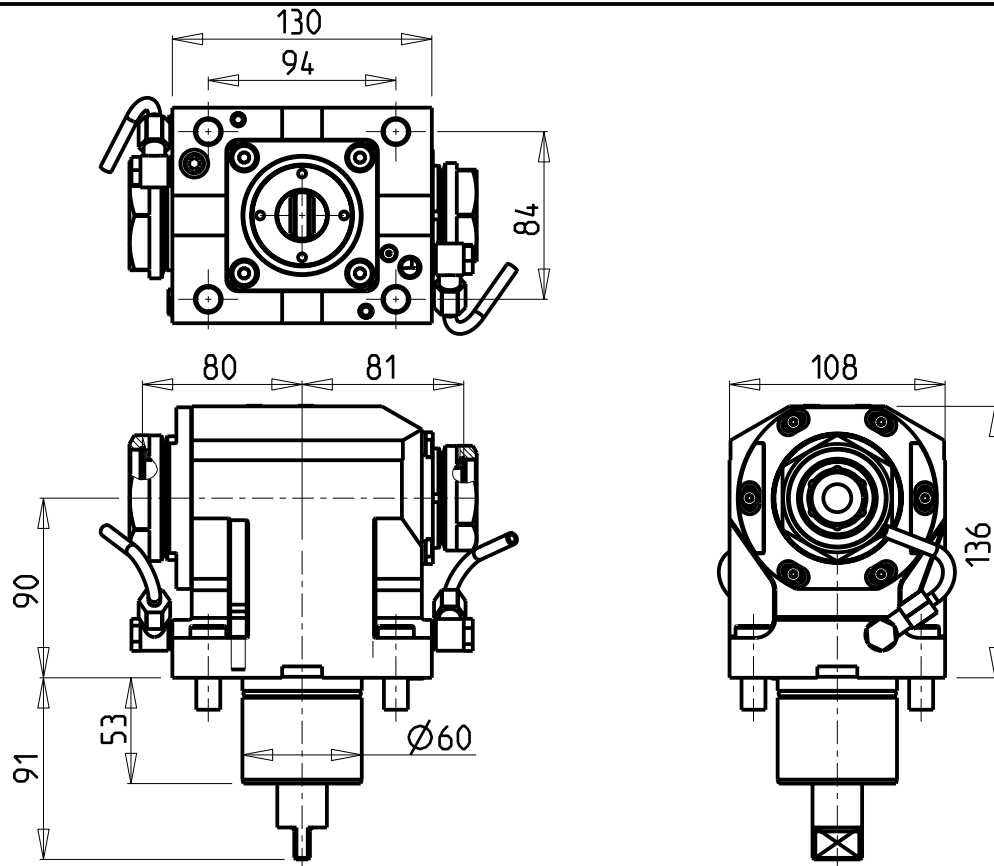

ATTENZIONE - ATTENTION - ACHTUNG

- Per lo smontaggio degli utensili utilizzare sempre la chiave di contrasto come indicato nel manuale d'uso.
- For disassembly of the tools use always the contrast key as mentioned in the user instructions.
- Fuer das Abmontieren der Werkzeuge immer den Gegenschlüssel benutzen wie in der Bedienungsanleitung erwaeht.

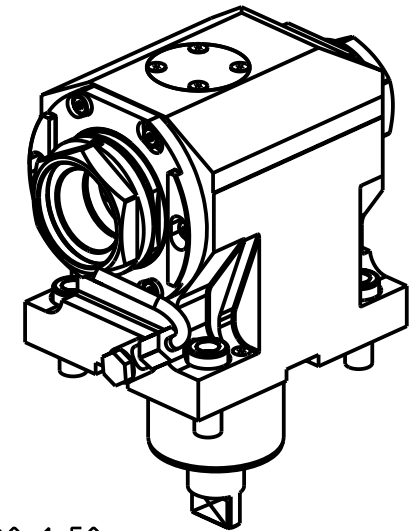

PER PORTAUTENSILI MODULARI MTSK-40 VEDI PAG. TBL300-1-40 E PER MTSK-50 VEDI PAG. TBL300-1-50
 FOR MTSK-40 QUIK CHANGE TOOLHOLDERS CLAMPINGS SEE PAGE TBL300-1-40 AND FOR MTSK-50 SEE PAGE TBL300-1-50
 FUER MTSK-40 MODULARE WERKZEUGAUFNAHMEN SIEHE SEITE TBL300-1-40 UND FUER MTSK-50 SIEHE SEITE TBL300-1-50

- Chiave inclusa
- Key included
- Schluessel inbegriffen

Cod. MT	Mandrino Spindle Spindel	I	RPM	Coppia Max Max Torque Max Drehmoment	Reversibile lato mandrino/contromandrino Reversible sub/main spindle side Umkehrbare Spindel-seite/ Gegenspindel-seite	Lubr.esterna Ext. coolant Aussenkuehlung	CHIAVI NON INCLUSE Keys not included Schluessel nicht einbegriffen		
							CHUB46	CHUB55	OKU0430007 *
MNL1015040	MTSK-50+MTSK-40	1:1	6000	100Nm	X	X	CHUB46	CHUB55	OKU0430007 *

DMG-MORI

NL1500/2000/2500/3000 12 STAZIONI - NLX1500/2000/2500/3000 12 STAZIONI - NLX4000 - NZL2000/2500 - NZX2500 (BMT60)
 NT4200/4250/4300/5400 - CTX2500 (BMT60)

MODULO MOTORIZZATO ASSIALE BISPORGENTE MTSK

Axial MTSK opposite face twin driven tool

Axial MTSK angetriebenes Werkzeug halb vorspringend

Subject to change without notice.

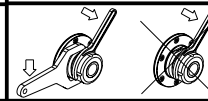

M.T. srl

Via Casino Albini 480
 Tel. 0541/956034-957884
 Fax 0541/956341
 47842 S. GIOVANNI IN M. (RN)
 e-mail: mtma@mtmarchetti.com
 http://www.mtmarchetti.com



PAGINA MNL240-1-10-K

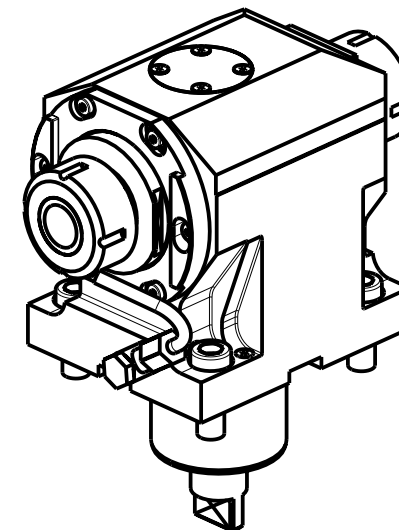
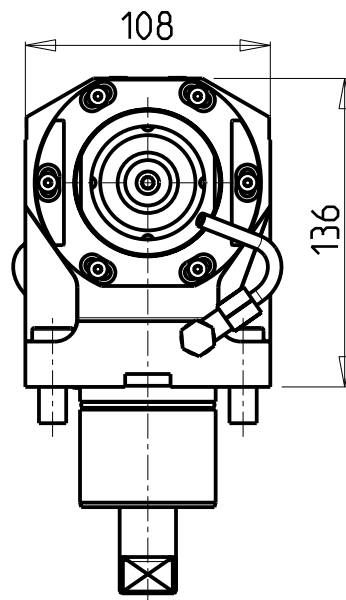
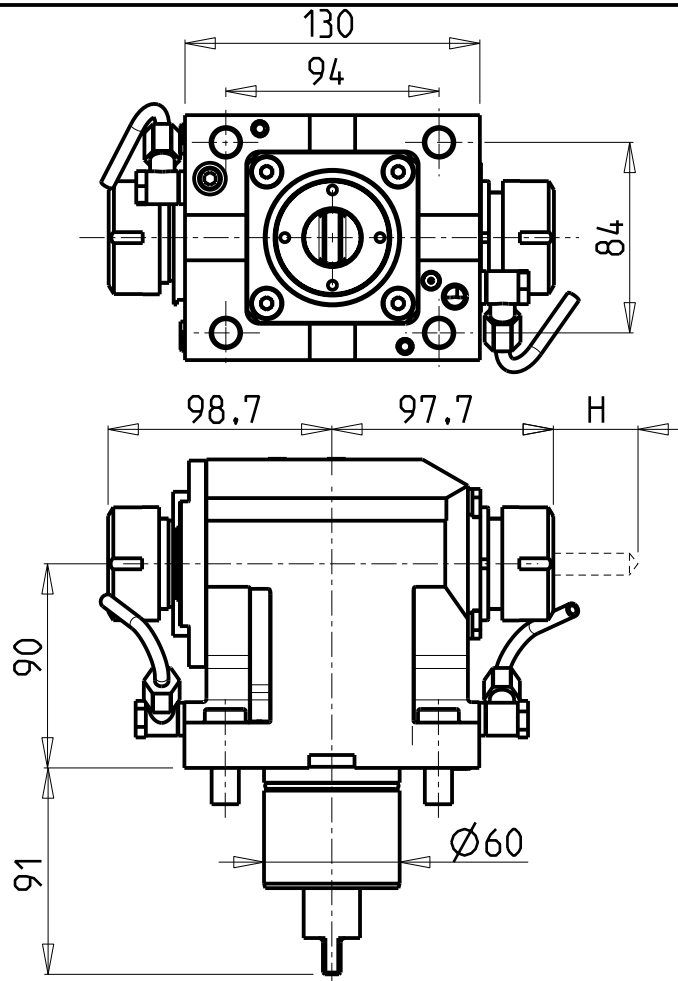

ATTENZIONE - ATTENTION - ACHTUNG

- Per lo smontaggio degli utensili utilizzare sempre la chiave di contrasto come indicato nel manuale d'uso.
- For disassembly of the tools use always the contrast key as mentioned in the user instructions.
- Fuer das Abmontieren der Werkzeuge immer den Gegenschlüssel benutzen wie in der Bedienungsanleitung erwaeht.

Cod. MT	Mandrino Spindle Spindel	I	RPM	Coppia Max Max Torque Max Drehmoment	Reversibile lato mandrino/contromandrino Reversible sub/main spindle side Umkehrbare Spindel-seite/ Gegenspindel-seite	Lubr.esterna Ext. coolant Aussenkuehlung	H Max Lato contromand. Subspindle side Gegenspindel-seite	CHIAVI NON INCLUSE Keys not included Schlüssel nicht einbegriffen
MNL0820232	ER32+ER32	1:1	10000	100Nm	X	X	74	OKU0430007 • CHSTER32

- Chiave inclusa
- Key included
- Schlüssel inbegriffen

DMG-MORI

NL1500/2000/2500/3000 12 STAZIONI - NLX1500/2000/2500/3000 12 STAZIONI - NLX4000 - NZL2000/2500 - NZX2500 (BMT60)
 NT4200/4250/4300/5400 - CTX2500 (BMT60)

MODULO MOTORIZZATO ASSIALE BISPORGENTE 10000 RPM

Axial opposite face twin driven tool 10000 rpm

Axial angetriebenes Werkzeug halb vorspringend 10000 rpm

Subject to change without notice.

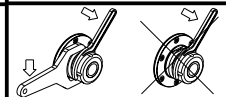

M.T. srl

Via Casino Albini 480
 Tel. 0541/956034-957884
 Fax 0541/956341
 47842 S. GIOVANNI IN M. (RN)
 e-mail: mtma@mtmarchetti.com
 http://www.mtmarchetti.com



PAGINA MNL240-1-11

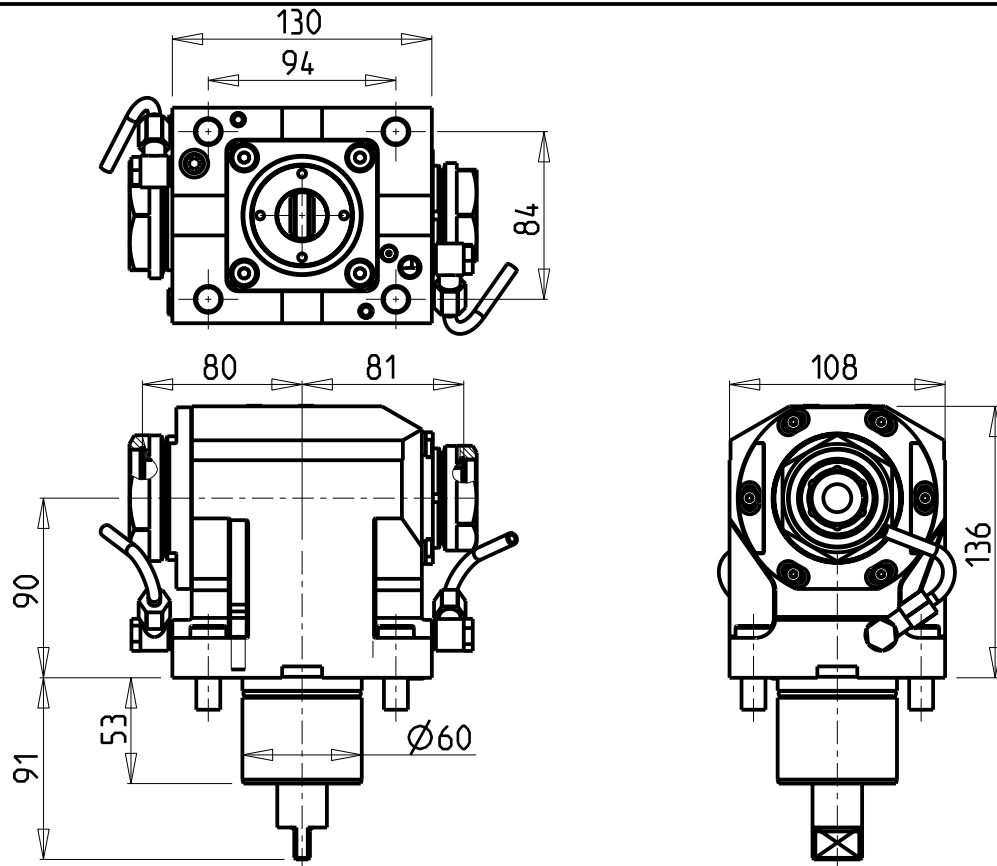

ATTENZIONE - ATTENTION - ACHTUNG

- Per lo smontaggio degli utensili utilizzare sempre la chiave di contrasto come indicato nel manuale d'uso.
- For disassembly of the tools use always the contrast key as mentioned in the user instructions.
- Fuer das Abmontieren der Werkzeuge immer den Gegenschlüssel benutzen wie in der Bedienungsanleitung erwaeht.

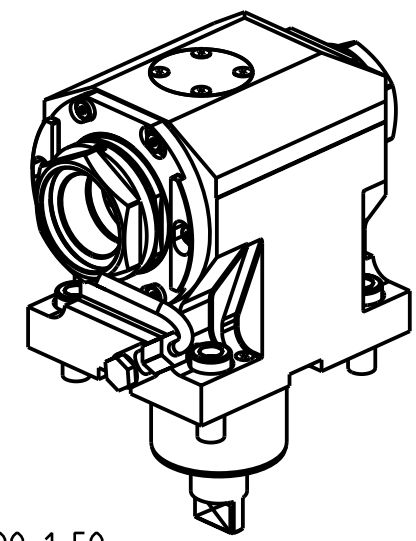

PER PORTAUTENSILI MODULARI MTSK-40 VEDI PAG. TBL300-1-40 E PER MTSK-50 VEDI PAG. TBL300-1-50
 FOR MTSK-40 QUIK CHANGE TOOLHOLDERS CLAMPINGS SEE PAGE TBL300-1-40 AND FOR MTSK-50 SEE PAGE TBL300-1-50
 FUER MTSK-40 MODULARE WERKZEUGAUFNAHMEN SIEHE SEITE TBL300-1-40 UND FUER MTSK-50 SIEHE SEITE TBL300-1-50

Cod. MT	Mandrino Spindle Spindel	I	RPM	Coppia Max Max Torque Max Drehmoment	Reversibile lato mandrino/contromandrino Reversible sub/main spindle side Umkehrbare Spindel-seite/ Gegenspindel-seite	Lubr.esterna Ext. coolant Aussenkuehlung	CHIAVI NON INCLUSE Keys not included Schluesssel nicht einbegriffen		
MNL1005040	MTSK-50+MTSK-40	1:1	10000	100Nm	X	X	CHUB46	CHUB55	OKU0430007 *

- Chiave inclusa
- Key included
- Schluesssel inbegriffen

DMG-MORI
 NL1500/2000/2500/3000 12 STAZIONI - NLX1500/2000/2500/3000 12 STAZIONI - NLX4000 - NZL2000/2500 - NZX2500 (BMT60)
 NT4200/4250/4300/5400 - CTX2500 (BMT60)

MODULO MOTORIZZATO ASSIALE BISPORGENTE MTSK 10000 RPM
 Axial MTSK opposite face twin driven tool 10000 rpm
 Axial MTSK angetriebenes Werkzeug halb vorspringend 10000 rpm

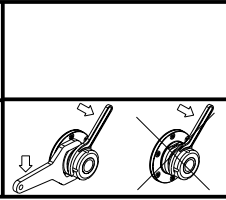

M.T. srl
 Via Casino Albini 480
 Tel. 0541/956034-957884
 Fax 0541/956341
 47842 S. GIOVANNI IN M. (RN)
 e-mail: mtma@mtmarchetti.com
 http://www.mtmarchetti.com



PAGINA MNL240-1-11-K

Subject to change without notice.

ATTENZIONE - ATTENTION - ACHTUNG

- Per lo smontaggio degli utensili utilizzare sempre la chiave di contrasto come indicato nel manuale d'uso.
- For disassembly of the tools use always the contrast key as mentioned in the user instructions.
- Fuer das Abmontieren der Werkzeuge immer den Gegenschlüssel benutzen wie in der Bedienungsanleitung erwaeht.

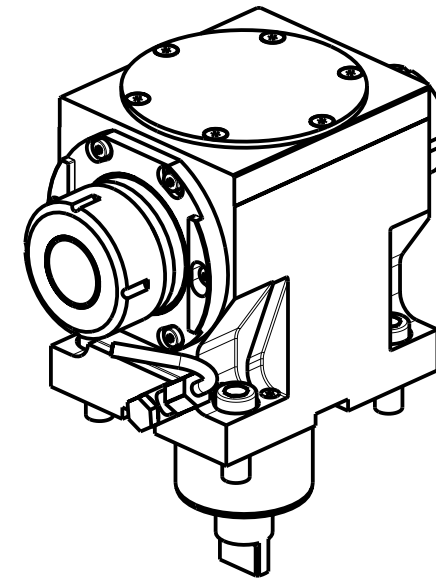
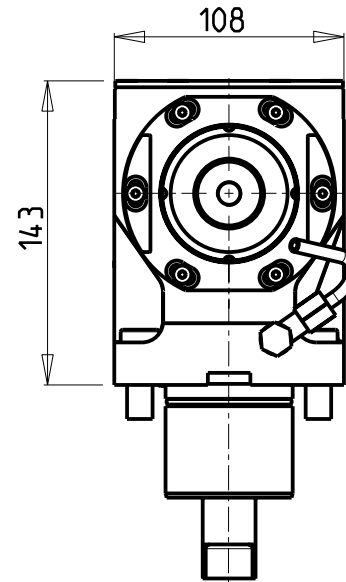
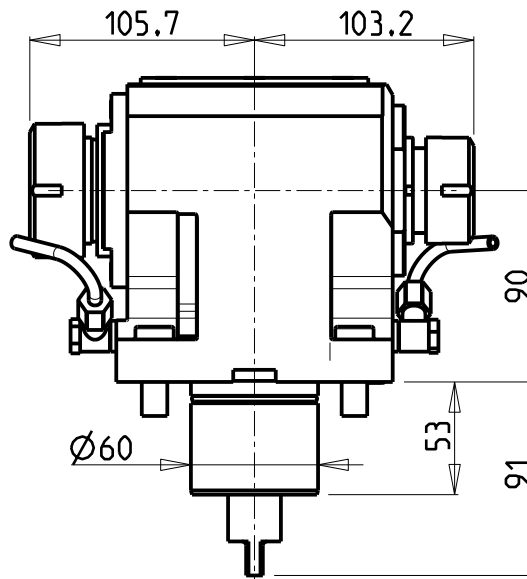
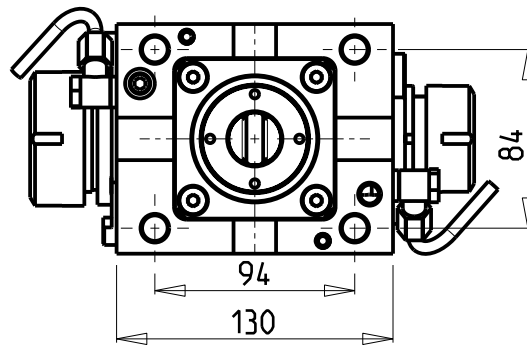

Cod. MT	Mandrino Spindle Spindel	I	RPM	Coppia Max Max Torque Max Drehmoment	Reversibile lato mandrino/contromandrino Reversible sub/main spindle side Umkehrbare Spindel-seite/ Gegenspindel-seite	Lubr.esterna Ext. coolant Aussenkuehlung	CHIAVI NON INCLUSE Keys not included Schluesssel nicht einbegriffen		
MNL0914032	ER40+ER32	2:1	3000	130Nm	X	X	OKU0430007	CHSTER40	CHSTER32

- Chiave inclusa
- Key included
- Schluesssel inbegriffen

DMG-MORI

NL1500/2000/2500/3000 12 STAZIONI - NLX1500/2000/2500/3000 12 STAZIONI - NLX4000 - NZL2000/2500 - NZX2500 (BMT60)
NT4200/4250/4300/5400 - CTX2500 (BMT60)

MODULO MOTORIZZATO ASSIALE BISPORGENTE RIDOTTO I=2:1

Axial geared-down I=2:1 opposite face twin driven tool

Axial angetriebenes Werkzeug halb vorspringend untersetzt I=2:1

Subject to change without notice.

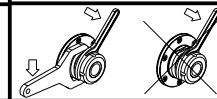

M.T. srl

Via Casino Albini 480
Tel. 0541/956034-957884
Fax 0541/956341
47842 S. GIOVANNI IN M. (RN)
e-mail: mtma@mtmarchetti.com
http://www.mtmarchetti.com



PAGINA MNL247-1-10

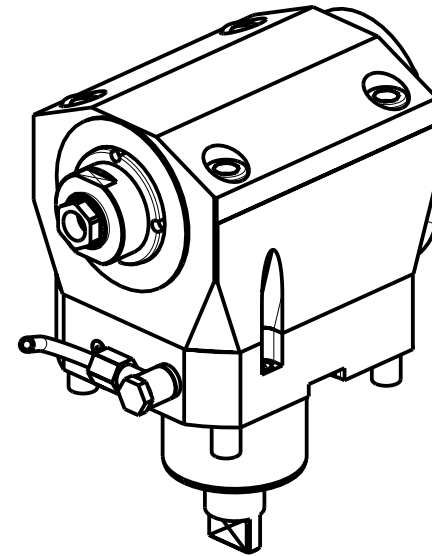
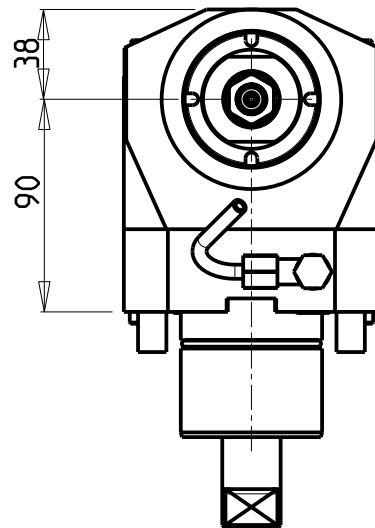
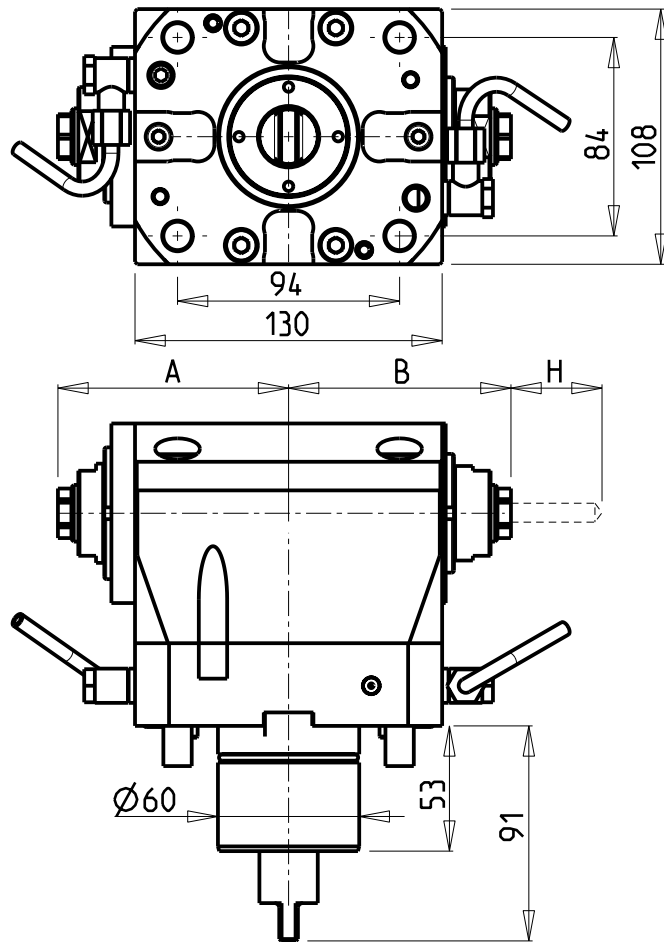

ATTENZIONE - ATTENTION - ACHTUNG

- Per lo smontaggio degli utensili utilizzare sempre la chiave di contrasto come indicato nel manuale d'uso.
- For disassembly of the tools use always the contrast key as mentioned in the user instructions.
- Fuer das Abmontieren der Werkzeuge immer den Gegenschlüssel benutzen wie in der Bedienungsanleitung erwaeht.

Cod. MT	Mandrino Spindle Spindel	I	RPM	Coppia Max Max Torque Max Drehmoment	Reversibile lato mandrino/contromandrino Reversible sub/main spindle side Umkehrbare Spindel-seite/ Gegenspindel-seite	Lubr.esterna Ext. coolant Aussenkuehlung	A	B	H Max Lato contromand. Subspindle side Gegenspindel-seite	CHIAVI NON INCLUSE Keys not included Schlüssel nicht einbegriffen	
										C HUB36	C HUB19_SP3
MNL0450116	ERA16+ERA16	1:2	12000	50Nm	X	X	97.63	94.13	77.6	C HUB36	C HUB19_SP3
MNL0450120	ERA20+ERA20	1:2	12000	50Nm	X	X	95.73	93.73	78	C HUB36	C HUB22

DMG-MORI

NL1500/2000/2500/3000 12 STAZIONI - NLX1500/2000/2500/3000 12 STAZIONI - NLX4000 - NZL2000/2500 - NZX2500 (BMT60)
NT4200/4250/4300/5400 - CTX2500 (BMT60)

MODULO MOTORIZZATO ASSIALE BISPORGENTE MOLTIPLICATO I=1:2

Axial geared-up I=1:2 opposite face twin driven tool

Axial angetriebenes Werkzeug halb vorspringend uebersetzt I=1:2

Subject to change without notice.

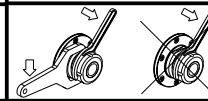

M.T. srl

Via Casino Albini 480
Tel. 0541/956034-957884
Fax 0541/956341
47842 S. GIOVANNI IN M. (RN)
e-mail: mtma@mtmarchetti.com
http://www.mtmarchetti.com



PAGINA MNL250-1-10

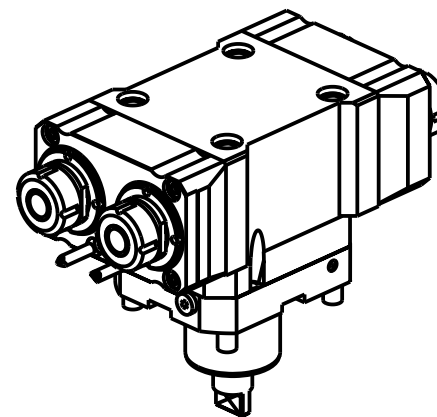
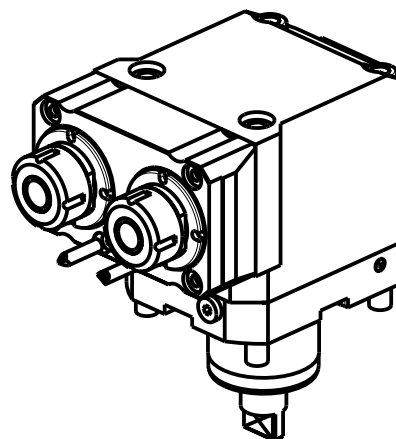
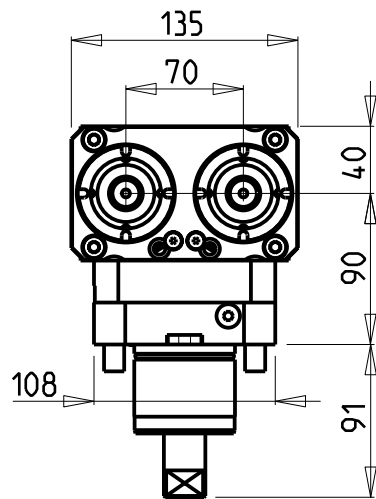
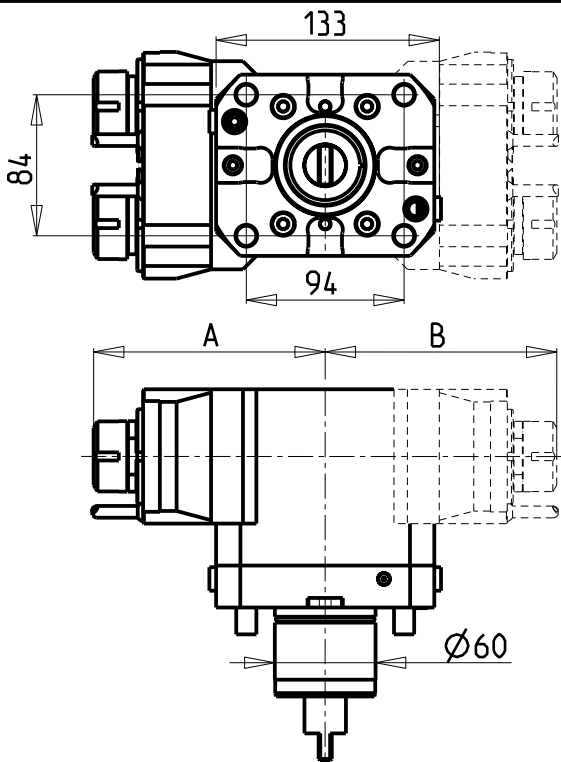

ATTENZIONE - ATTENTION - ACHTUNG

- Per lo smontaggio degli utensili utilizzare sempre la chiave di contrasto come indicato nel manuale d'uso.
- For disassembly of the tools use always the contrast key as mentioned in the user instructions.
- Fuer das Abmontieren der Werkzeuge immer den Gegenschlüssel benutzen wie in der Bedienungsanleitung erwäehnt.

- Chiave inclusa
- Key included
- Schluessel inbegriffen

Cod. MT	Mandrino Spindle Spindel	I	RPM	Coppia Max Max Torque Max Drehmoment	N°Utensili N° Tools N° Werkzeuge	Reversibile lato mandrino/contromandrino Reversible sub/main spindle side Umkehrbare Spindelsete/ Gegenspindelsete	Lubr.interna Coolant through Innenkuehlung	Lubr.esterna Ext. coolant Aussenkuehlung	A	B	CHIAVI NON INCLUDE Keys not included Schluessel nicht einbegriffen		
MNL0220225	ER25	1:1	6000	40Nm	2	X	-	X	137.96	68	CHUB36	CHSTER25	-
MNL0221225	ER25	1:1	6000	40Nm	2	X	P=70bar	X	162.66	68	CHUB36	CHSTER25	-
MNL0220325	ERA25	1:1	6000	40Nm	2	X	-	X	126.5	68	CHUB38	CHUB27	CHTAER25ZC • NEW
MNL0221325	ERA25	1:1	6000	40Nm	2	X	P=70bar	X	156.03	68	CHUB38	CHUB27	-
MNL1250225	ER25+ER25	1:1	6000	40Nm	2+2	X	-	X	137.96	137.96	CHUB36	CHSTER25	- NEW
MNL1250325	ERA25+ERA25	1:1	6000	40Nm	2+2	X	-	X	126.5	126.5	CHUB38	CHUB27	CHTAER25ZC • NEW

DMG-MORI

NL1500/2000/2500/3000 12 STAZIONI - NLX1500/2000/2500/3000 12 STAZIONI - NLX4000 - NZL2000/2500 - NZX2500 (BMT60)
NT4200/4250/4300/5400 - NTX2000/2500/3000 2ND GEN. 10ST. - CTX2500 (BMT60)

MODULO MOTORIZZATO ASSIALE 2 USCITE IN Y
Axial Single side twin head driven tool in Y
Axial angetriebenes Werkzeug 2 Ausgaenge in Y

Subject to change without notice.

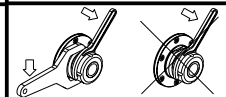

M.T. srl

Via Casino Albini 480
Tel. 0541/956034-957884
Fax 0541/956341
47842 S. GIOVANNI IN M. (RN)
e-mail: mtma@mtmarchetti.com
http://www.mtmarchetti.com



PAGINA MNL260-1-10

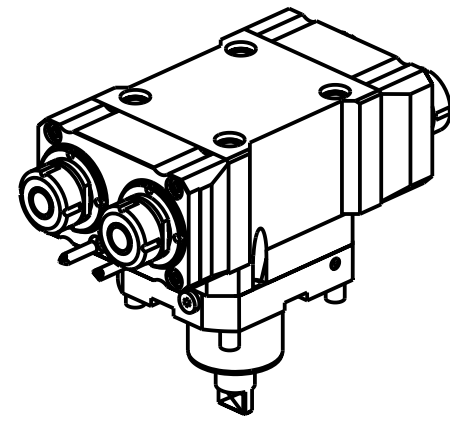
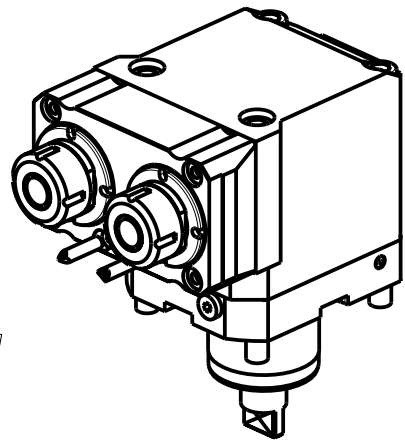
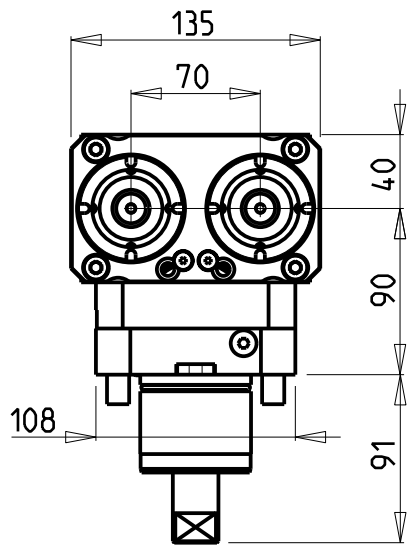
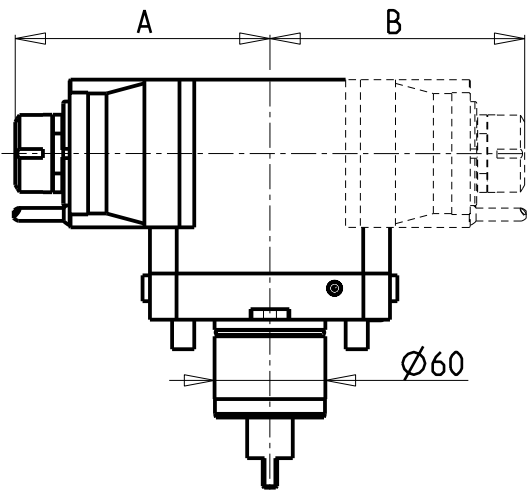
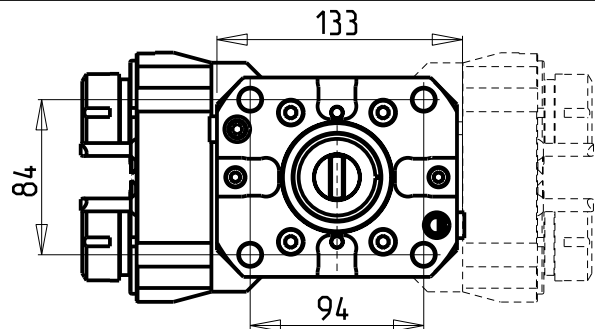

ATTENZIONE - ATTENTION - ACHTUNG

- Per lo smontaggio degli utensili utilizzare sempre la chiave di contrasto come indicato nel manuale d'uso.
- For disassembly of the tools use always the contrast key as mentioned in the user instructions.
- Fuer das Abmontieren der Werkzeuge immer den Gegenschlüssel benutzen wie in der Bedienungsanleitung erwäehnt.

Cod. MT	Mandrino Spindel Spindel	I	RPM	Coppia Max Max Torque Max Drehmoment	N°Utensili N°Tools N°Werkzeuge	Reversibile lato mandrino/contromandrino Reversible sub/main spindle side Umkehrbare Spindelsete/Gegenspindelsete	Lubr.esterna Ext. coolant Aussenkuehlung	A	B	CHIAVI NON INCLUDE Keys not included Schluessel nicht einbegriffen		
MNL1060225	ER25	1:1	10000	40Nm	2	X	X	137.96	68	CHUB36	CHSTER25	-
MNL1060325	ERA25	1:1	10000	40Nm	2	X	X	126.5	68	CHUB38	CHUB27	CHTAER25ZC
MNL1240225	ER25+ER25	1:1	10000	40Nm	2+2	X	X	137.96	137.96	CHUB36	CHSTER25	-
MNL1240325	ERA25+ERA25	1:1	10000	40Nm	2+2	X	X	126.5	126.5	CHUB38	CHUB27	CHTAER25ZC

- Chiave inclusa
- Key included
- Schluessel inbegriffen

NEW
NEW
NEW

DMG-MORI
 NL1500/2000/2500/3000 12 STAZIONI - NLX1500/2000/2500/3000 12 STAZIONI - NLX4000 - NZL2000/2500 - NZX2500 (BMT60)
 NT4200/4250/4300/5400 - NTX2000/2500/3000 2ND GEN. 10ST. - CTX2500 (BMT60)

MODULO MOTORIZZATO ASSIALE 2 USCITE IN Y 10000 RPM
 Axial Single side twin head driven tool in Y 10000 rpm
 Axial angetriebenes Werkzeug 2 Ausgaenge in Y 10000 rpm

Subject to change without notice.

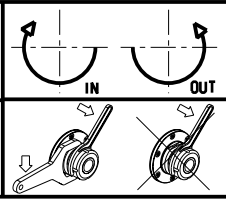

M.T. srl
 Via Casino Albini 480
 Tel. 0541/956034-957884
 Fax 0541/956341
 47842 S. GIOVANNI IN M. (RN)
 e-mail: mtma@mtmarchetti.com
 http://www.mtmarchetti.com



PAGINA MNL260-1-11

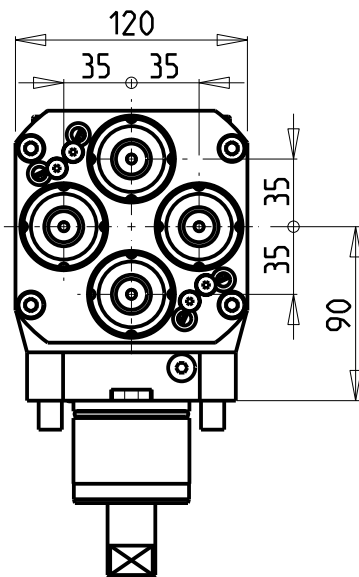
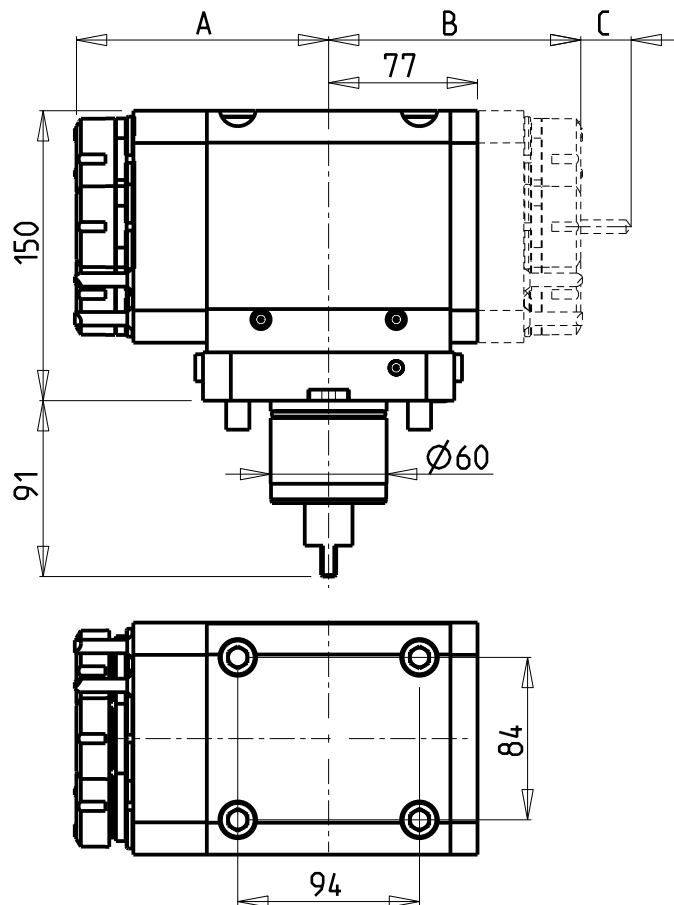

ATTENZIONE - ATTENTION - ACHTUNG

- Per lo smontaggio degli utensili utilizzare sempre la chiave di contrasto come indicato nel manuale d'uso.
- For disassembly of the tools use always the contrast key as mentioned in the user instructions.
- Fuer das Abmontieren der Werkzeuge immer den Gegenschlüssel benutzen wie in der Bedienungsanleitung erwaeht.

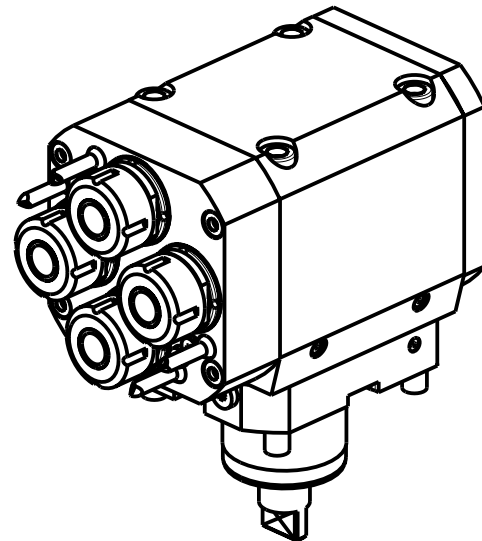

Cod. MT	Mandrino Spindle Spindel	I	RPM	Coppia Max Max Torque Max Drehmoment	N°Utensili N°Tools N°Werkzeuge	Reversibile lato mandrino/contromandrino Reversible sub/main spindle side Umkehrbare Spindel-seite/ Gegenspindel-seite	Lubr.esterna Ext. coolant Aussehenkehlung	A	B	C max Lato contromandrino Subspindle side Gegenspindel-seite	CHIAVI INCLUSE Keys included Schluessel inbegriffen	
MNL0230425	ER25	1:1	6000	30Nm	4	X	X	130.46	-	-	MNL0210007	MNL0210008
MNL0234425	ER25+ER25	1:1	6000	30Nm	4+4	-	X	130.46	130.46	36	MNL0210007	MNL0210008

DMG-MORI
 NL1500/2000/2500/3000 12 STAZIONI - NLX1500/2000/2500/3000 12 STAZIONI - NLX4000 - NZL2000/2500 - NZX2500 (BMT60)
 NT4200/4250/4300/5400 - NTX2000/2500/3000 2ND GEN. 10ST. - CTX2500 (BMT60)

MODULO MOTORIZZATO ASSIALE 4/8 USCITE
 Axial multiple 4/8 outlet driven tool
 Axial angetriebenes Mehrspindel-Werkzeug 4/8 Ausgaenge

Subject to change without notice.

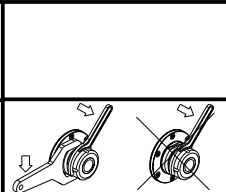

M.T. srl
 Via Casino Albini 480
 Tel. 0541/956034-957884
 Fax 0541/956341
 47842 S. GIOVANNI IN M. (RN)
 e-mail: mtma@mtmarchetti.com
 http://www.mtmarchetti.com



PAGINA MNL270-1-00

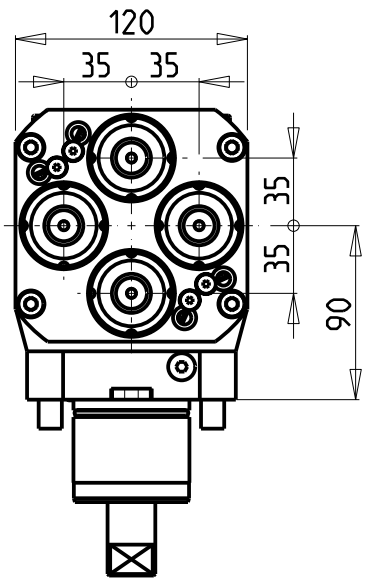
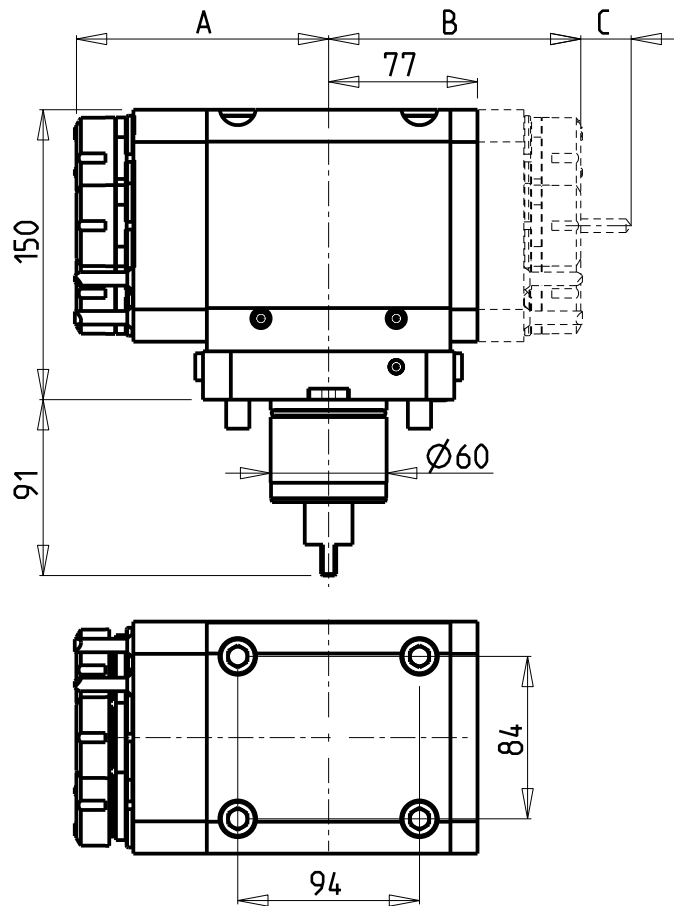

ATTENZIONE - ATTENTION - ACHTUNG

- Per lo smontaggio degli utensili utilizzare sempre la chiave di contrasto come indicato nel manuale d'uso.
- For disassembly of the tools use always the contrast key as mentioned in the user instructions.
- Fuer das Abmontieren der Werkzeuge immer den Gegenschlüssel benutzen wie in der Bedienungsanleitung erwaeht.

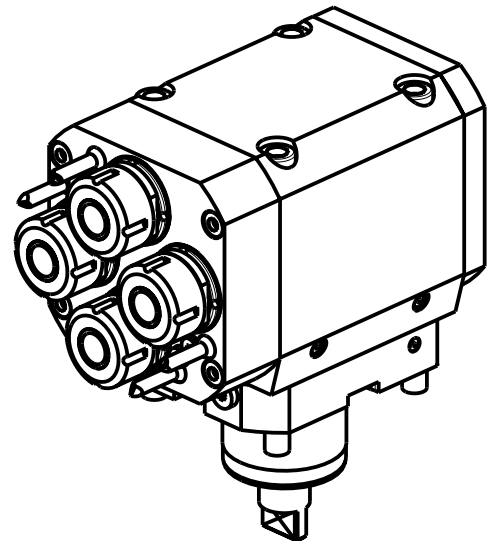

Cod. MT	Mandrino Spindle Spindel	I	RPM	Coppia Max Max Torque Max Drehmoment	N°Utensili N°Tools N°Werkzeuge	Reversibile lato mandrino/contromandrino Reversible sub/main spindle side Umkehrbare Spindel-seite/ Gegenspindel-seite	Lubr.esterna Ext. coolant Aussenkehlung	A	B	C max Lato contromandrino Subspindle side Gegenspindel-seite	CHIAVI INCLUSE Keys included Schluessel inbegriffen	
											MNL0210007	MNL0210008
MNL1110425	ER25	1:1	10000	30Nm	4	X	X	130.96	-	-	MNL0210007	MNL0210008
MNL1114425	ER25+ER25	1:1	10000	30Nm	4+4	X	X	130.96	130.96	36	MNL0210007	MNL0210008

DMG-MORI
 NL1500/2000/2500/3000 12 STAZIONI - NLX1500/2000/2500/3000 12 STAZIONI - NLX4000 - NZL2000/2500 - NZX2500 (BMT60)
 NT4200/4250/4300/5400 - NTX2000/2500/3000 2ND GEN. 10ST. - CTX2500 (BMT60)

MODULO MOTORIZZATO ASSIALE 4/8 USCITE 10000 RPM
 Axial multiple 4/8 outlet driven tool 10000 rpm
 Axial angetriebenes Mehrspindel-Werkzeug 4/8 Ausgaenge 10000 rpm

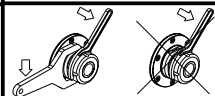

M.T. srl
 Via Casino Albini 480
 Tel. 0541/956034-957884
 Fax 0541/956341
 47842 S. GIOVANNI IN M. (RN)
 e-mail: mtma@mtmarchetti.com
 http://www.mtmarchetti.com



PAGINA MNL270-1-01

Subject to change without notice.

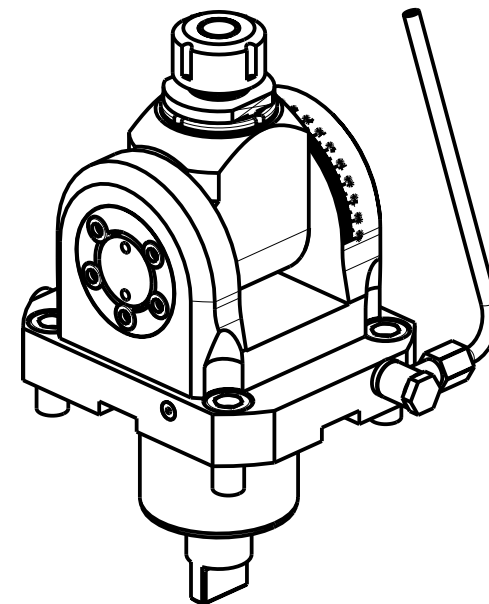
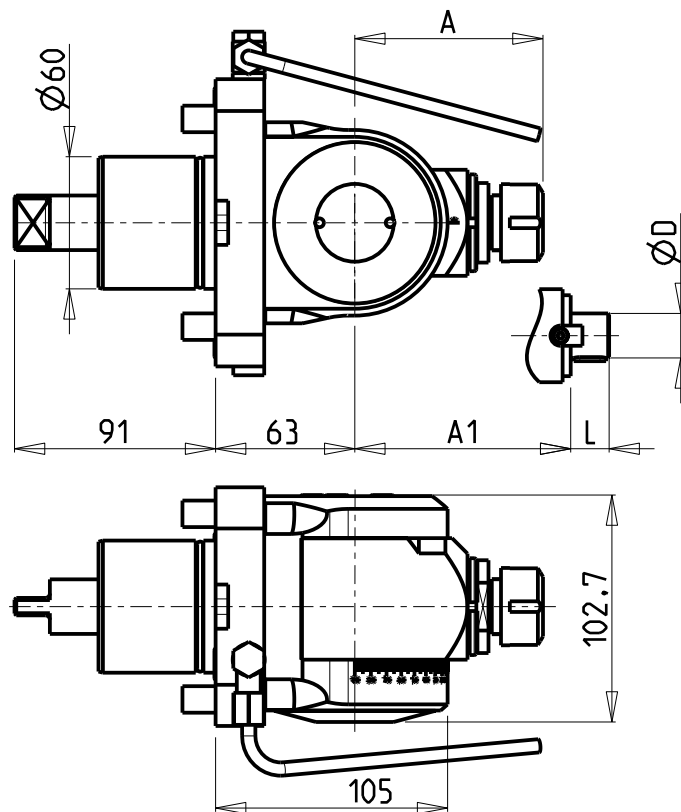
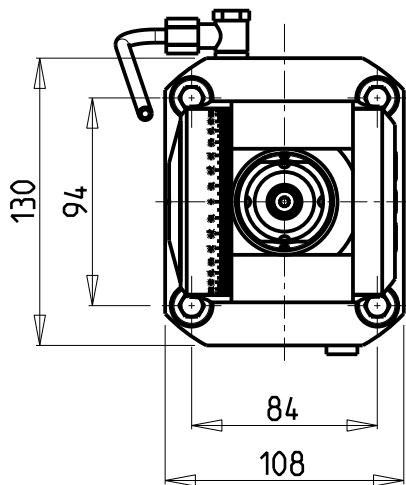

Cod. MT	Mandrino Spindle Spindel	i	RPM	Coppia Max Max Torque Max Drehmoment	Reversibile lato mandrino/contromandrino Reversible sub/main spindle side Umkehrbare Spindel-seite/ Gegenspindel-seite	Lubr. esterna Ext. coolant Aussenkuehlung	A	A1	D	L	CHIAVI INCLUSE Keys included Schluessel inbegriffen		
											CHUB36	CHSTER	CHESL
MNL0930120	ER20	1:1	6000	40Nm	X	X	85.16	-	-	-	CHUB36	CHSTER20	CHESL10
MNL0930125	ER25	1:1	6000	40Nm	X	X	86.16	-	-	-	CHUB36	CHSTER25	CHESL10
MNL0930516	Ø16x17	1:1	6000	40Nm	X	X	-	65	16	17	CHUB36	CH_VTCROCE_M08	CHESL10
MNL0930522	Ø22x19	1:1	6000	40Nm	X	X	-	66	22	19	CHUB36	CH_VTCROCE_M10	CHESL10
MNL0930519	Ø3/4"x3/4"	1:1	6000	40Nm	X	X	-	65	3/4"	3/4"	CHUB36	CH_VTCROCE_M08	CHESL10

DMG-MORI

NL1500/2000/2500/3000 12 STAZIONI - NLX1500/2000/2500/3000 12 STAZIONI - NLX4000 - NZL2000/2500 - NZX2500 (BMT60)
 NT4200/4250/4300/5400 - NTX2000/2500/3000 2ND GEN. 10ST. - CTX2500 (BMT60)

MODULO MOTORIZZATO ORIENTABILE ±90°

±90° adjustable angle driven tool

Angetriebenes Werkzeug schwenkbar ±90°

Subject to change without notice.

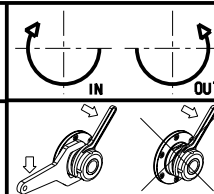

M.T. srl

Via Casino Albini 480
 Tel. 0541/956034-957884

Fax 0541/956341

47842 S. GIOVANNI IN M. (RN)

e-mail: mtma@tmarchetti.com

http://www.tmmarchetti.com



PAGINA MNL333-1-00

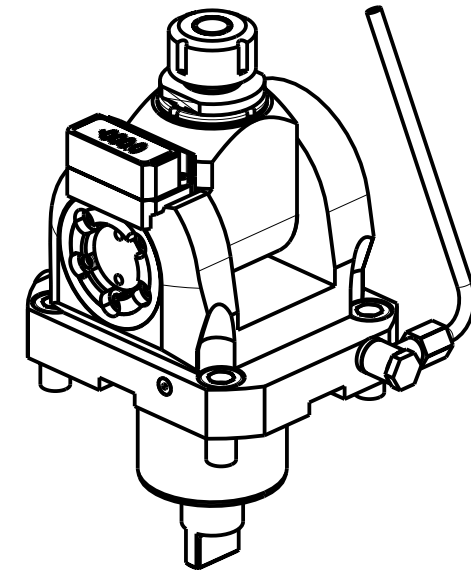
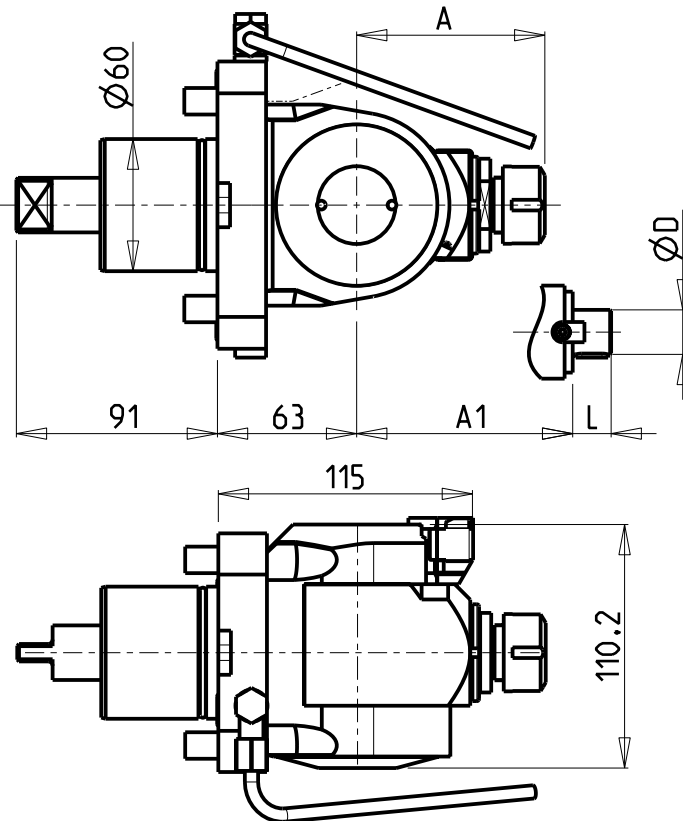
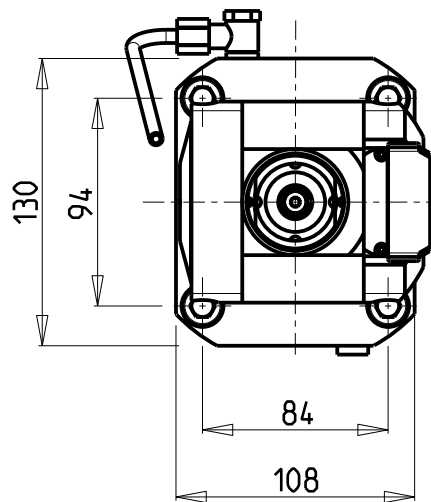

Cod. MT	Mandrino Spindle Spindel	i	RPM	Coppia Max Max Torque Max Drehmoment	Reversibile lato mandrino/contromandrino Reversible sub/main spindle side Umkehrbare Spindel-seite/ Gegenspindel-seite	Lubr.esterna Ext. coolant Aussenkuehlung	A	A1	D	L	CHIAVI INCLUSE Keys included Schluessel inbegriffen		
											CHUB36	CHSTER	CHESL10
MNL0890120	ER20	1:1	6000	40Nm	X	X	85.16	-	-	-	CHUB36	CHSTER20	CHESL10
MNL0890125	ER25	1:1	6000	40Nm	X	X	86.16	-	-	-	CHUB36	CHSTER25	CHESL10
MNL0890516	Ø16x17	1:1	6000	40Nm	X	X	-	65	16	17	CHUB36	CH_VTCROCE_M08	CHESL10
MNL0890522	Ø22x19	1:1	6000	40Nm	X	X	-	66	22	19	CHUB36	CH_VTCROCE_M10	CHESL10
MNL0890519	Ø3/4"x3/4"	1:1	6000	40Nm	X	X	-	65	3/4"	3/4"	CHUB36	CH_VTCROCE_M08	CHESL10

DMG-MORI

NL1500/2000/2500/3000 12 STAZIONI - NLX1500/2000/2500/3000 12 STAZIONI - NLX4000 - NZL2000/2500 - NZX2500 (BMT60)
 NT4200/4250/4300/5400 - NTX2000/2500/3000 2ND GEN. 10ST. - CTX2500 (BMT60)

MODULO MOTORIZZATO ORIENTABILE ±90° CON NONIO DIGITALE

±90° adjustable angle driven tool with digital display

Angetriebenes Werkzeug schwenkbar ±90° mit digital display

Subject to change without notice.

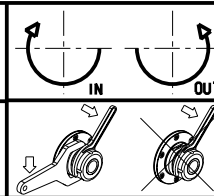

M.T. srl

Via Casino Albini 480
 Tel. 0541/956034-957884

Fax 0541/956341

47842 S. GIOVANNI IN M. (RN)

e-mail: mtma@mtmarchetti.com

http://www.mtmarchetti.com



PAGINA MNL333-1-01

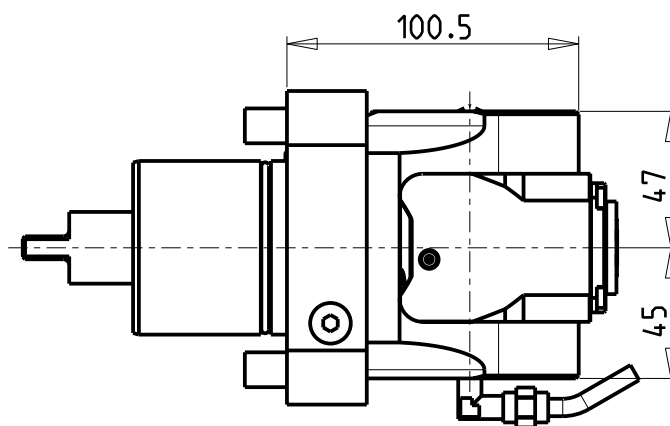
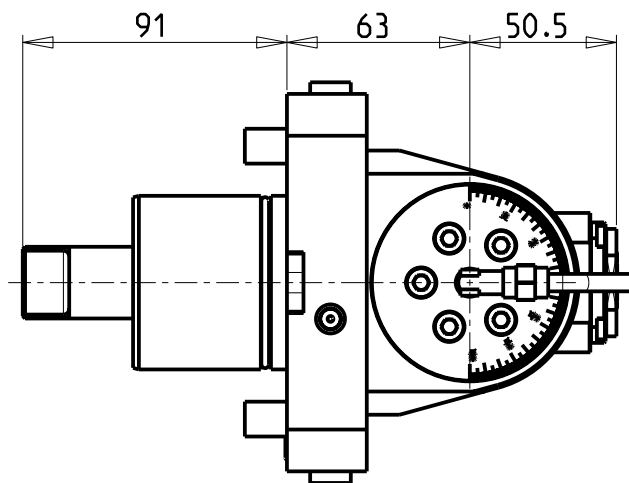
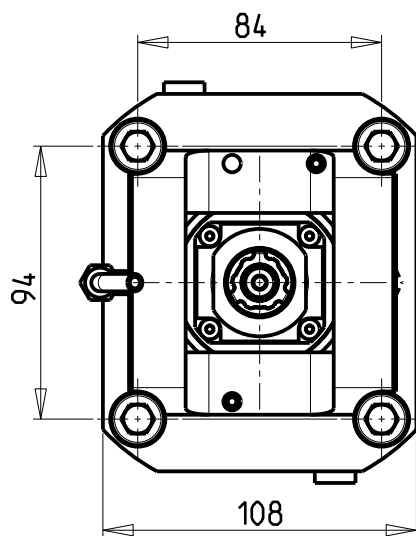

ATTENZIONE - ATTENTION - ACHTUNG

- Per lo smontaggio degli utensili utilizzare sempre la chiave di contrasto come indicato nel manuale d'uso.
- For disassembly of the tools use always the contrast key as mentioned in the user instructions.
- Fuer das Abmontieren der Werkzeuge immer den Gegenschlüssel benutzen wie in der Bedienungsanleitung erwäehnt.

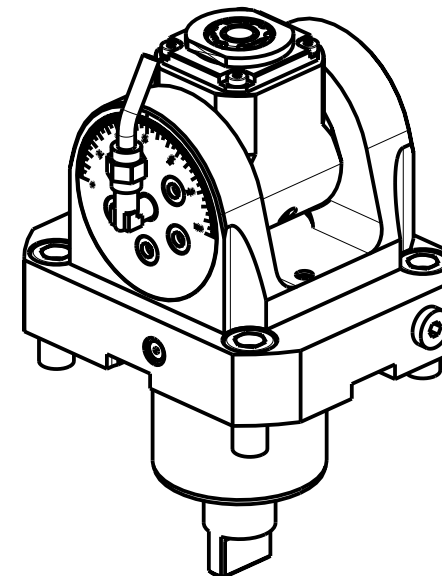

Cod. MT	Mandrino Spindle Spindel	I	RPM	Coppia Max Max Torque Max Drehmoment	Lubrificazione int. Coolant through Innenkuehlung	Lubrificazione est. Ext. coolant Aussenkuehlung	CHIAVI INCLUSE Keys included Schluesssel inbegriffen			
							CHUB22	CHUB36	CHTAER20ZC	CHESL10
MNL0640120	ERA20	1:1	6000	30Nm	-	X	CHUB22	CHUB36	CHTAER20ZC	CHESL10
MNL0640220	ERA20	1:1	6000	30Nm	P=70bar	X	CHUB22	CHUB36	CHTAER20ZC	CHESL10

DMG-MORI

NL1500/2000/2500/3000 12 STAZIONI - NLX1500/2000/2500/3000 12 STAZIONI - NLX4000 - NZL2000/2500 - NZX2500 (BMT60)
NT4200/4250/4300/5400 - NTX2000/2500/3000 2ND GEN. 10ST. - CTX2500 (BMT60)

MODULO MOTORIZZATO ORIENTABILE +/-90°

+/-90° adjustable angle driven tool

Angetriebenes Werkzeug schwenkbar +/-90°

Subject to change without notice.

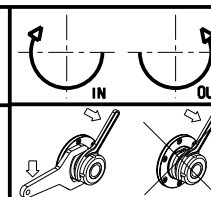

M.T. srl

Via Casino Albini 480
Tel. 0541/956034-957884
Fax 0541/956341
47842 S. GIOVANNI IN M. (RN)
e-mail: mtma@mtmarchetti.com
http://www.mtmarchetti.com



PAGINA MNL335-1-00

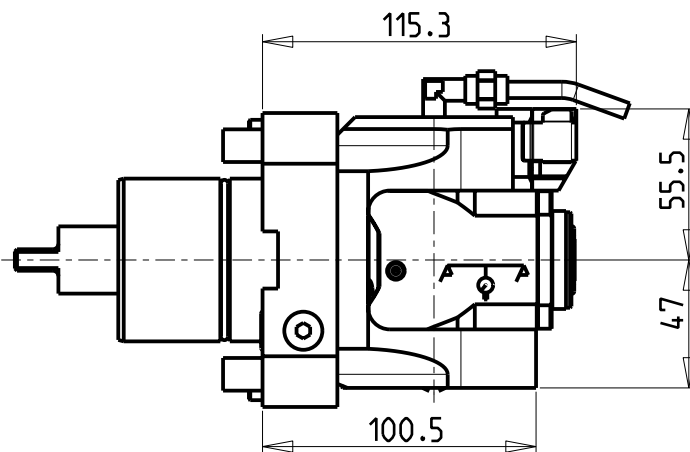
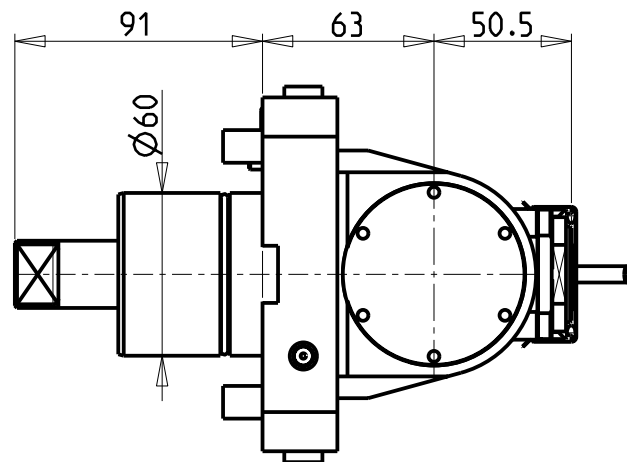
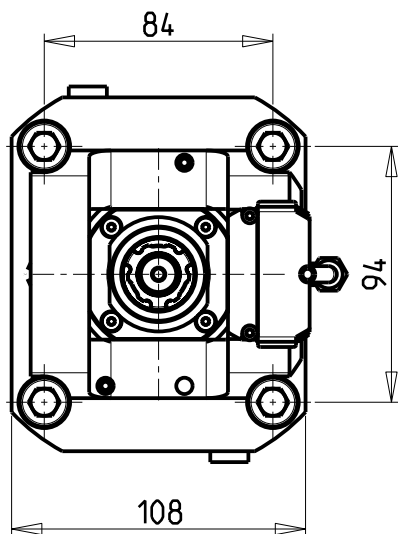

ATTENZIONE - ATTENTION - ACHTUNG

- Per lo smontaggio degli utensili utilizzare sempre la chiave di contrasto come indicato nel manuale d'uso.
- For disassembly of the tools use always the contrast key as mentioned in the user instructions.
- Fuer das Abmontieren der Werkzeuge immer den Gegenschlüssel benutzen wie in der Bedienungsanleitung erwäehnt.

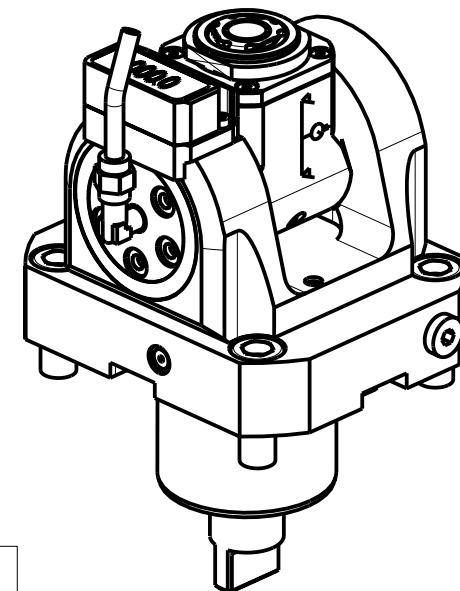

Cod. MT	Mandrino Spindle Spindel	I	RPM	Coppia Max Max Torque Max Drehmoment	Lubrificazione int. Coolant through Innenkuehlung	Lubrificazione est. Ext. coolant Ausseenkuehlung	CHIAVI INCLUSE Keys included Schluessel inbegriffen			
							CHUB22	CHUB36	CHTAER20ZC	CHESL10
MNL0645120	ERA20	1:1	6000	30Nm	-	X	CHUB22	CHUB36	CHTAER20ZC	CHESL10
MNL0645220	ERA20	1:1	6000	30Nm	P=70bar	X	CHUB22	CHUB36	CHTAER20ZC	CHESL10

DMG-MORI

NL1500/2000/2500/3000 12 STAZIONI - NLX1500/2000/2500/3000 12 STAZIONI - NLX4000 - NZL2000/2500 - NZX2500 (BMT60)
 NT4200/4250/4300/5400 - NTX2000/2500/3000 2ND GEN. 10ST. - CTX2500 (BMT60)

MODULO MOTORIZZATO ORIENTABILE +/-90° CON NONIO DIGITALE

+/-90° adjustable angle driven tool with digital display

Angetriebenes Werkzeug schwenkbar +/-90° mit digital display

Subject to change without notice.

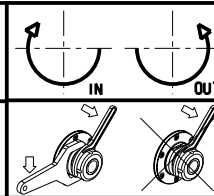

M.T. srl

Via Casino Albini 480
 Tel. 0541/956034-957884
 Fax 0541/956341
 47842 S. GIOVANNI IN M. (RN)
 e-mail: mtma@mtmarchetti.com
 http://www.mtmarchetti.com



PAGINA MNL335-1-01

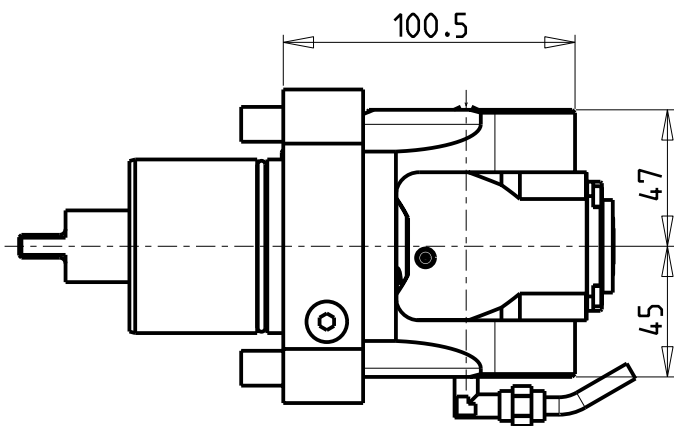
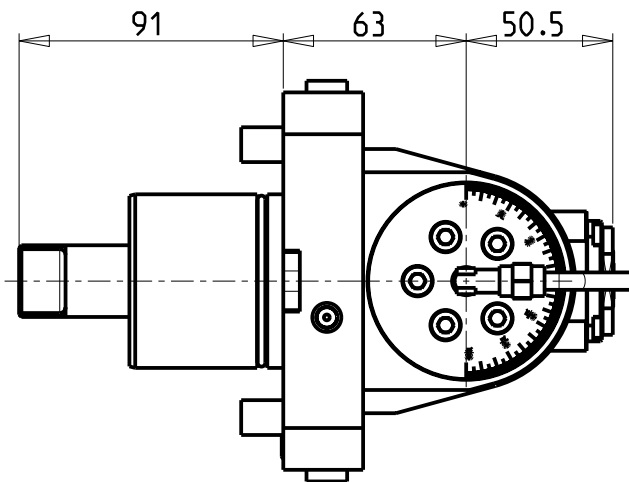
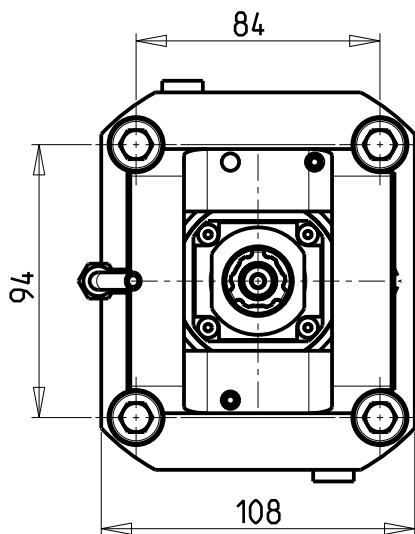

ATTENZIONE - ATTENTION - ACHTUNG

- Per lo smontaggio degli utensili utilizzare sempre la chiave di contrasto come indicato nel manuale d'uso.
- For disassembly of the tools use always the contrast key as mentioned in the user instructions.
- Fuer das Abmontieren der Werkzeuge immer den Gegenschlüssel benutzen wie in der Bedienungsanleitung erwaeht.

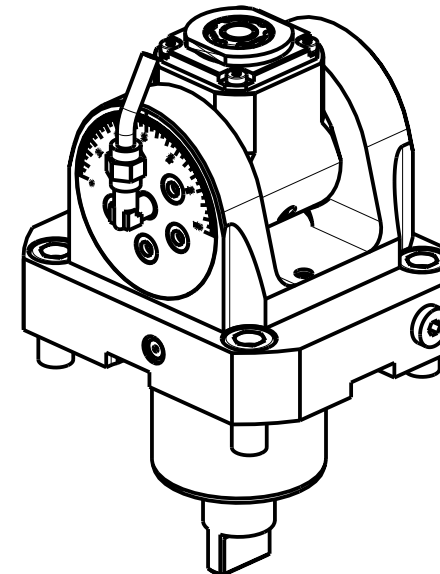

Cod. MT	Mandrino Spindle Spindel	I	RPM	Coppia Max Max Torque Max Drehmoment	Lubrificazione int. Coolant through Innenkuehlung	Lubrificazione est. Ext. coolant Aussenkuehlung	CHIAVI INCLUSE Keys included Schluessel inbegriffen			
MNL0640316	ERA16	1:2	12000	8Nm	-	X	CHUB19_SP3	CHUB32	CHTAER16ZC	CHESL10
MNL0640416	ERA16	1:2	12000	8Nm	P=70bar	X	CHUB19_SP3	CHUB32	CHTAER16ZC	CHESL10

DMG-MORI

NL1500/2000/2500/3000 12 STAZIONI - NLX1500/2000/2500/3000 12 STAZIONI - NLX4000 - NZL2000/2500 - NZX2500 (BMT60)
 NT4200/4250/4300/5400 - NTX2000/2500/3000 2ND GEN. 10ST. - CTX2500 (BMT60)

MODULO MOTORIZZATO ORIENTABILE +/-90° MOLTIPLICATO I=1:2

+/-90° adjustable angle driven tool geared-up I=1:2

Angetriebenes Werkzeug schwenkbar +/-90° uebersetzt I=1:2

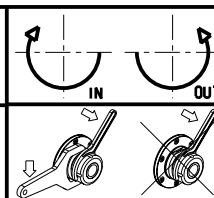

M.T. srl

Via Casino Albini 480
 Tel. 0541/956034-957884
 Fax 0541/956341
 47842 S. GIOVANNI IN M. (RN)
 e-mail: mtma@mtmarchetti.com
 http://www.mtmarchetti.com



PAGINA MNL336-1-00

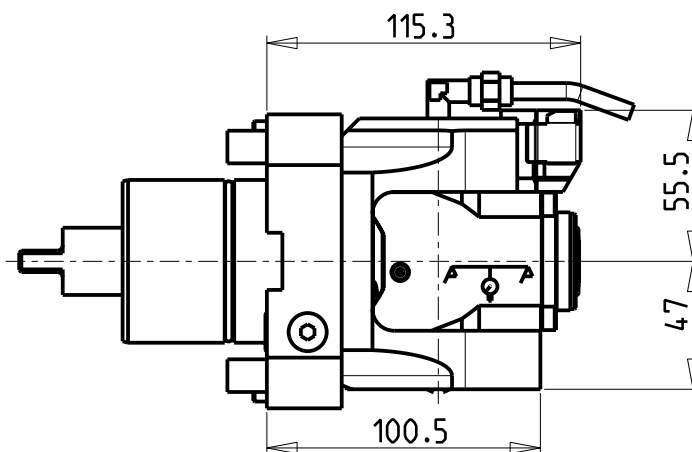
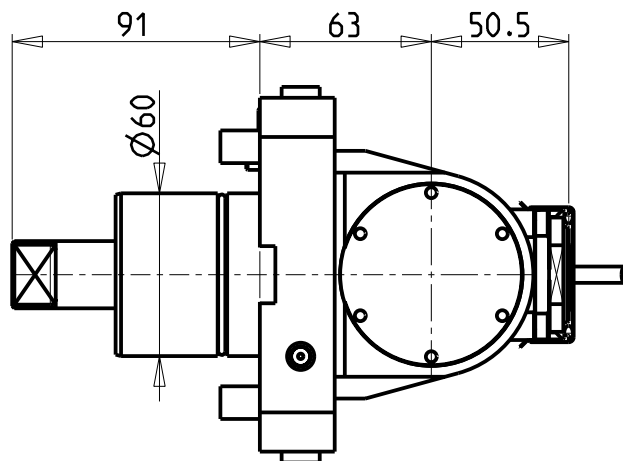
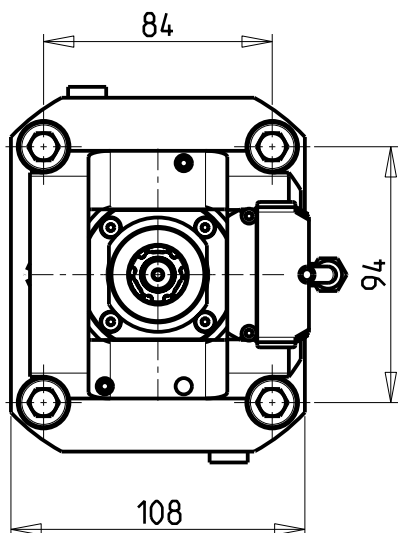

ATTENZIONE - ATTENTION - ACHTUNG

- Per lo smontaggio degli utensili utilizzare sempre la chiave di contrasto come indicato nel manuale d'uso.
- For disassembly of the tools use always the contrast key as mentioned in the user instructions.
- Fuer das Abmontieren der Werkzeuge immer den Gegenschlüssel benutzen wie in der Bedienungsanleitung erwäehnt.

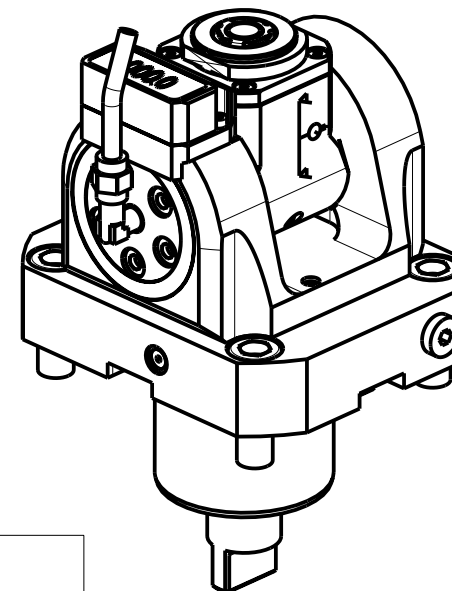

Cod. MT	Mandrino Spindle Spindel	I	RPM	Coppia Max Max Torque Max Drehmoment	Lubrificazione int. Coolant through Innenkuehlung	Lubrificazione est. Ext. coolant Aussenkuehlung	CHIAVI INCLUSE Keys included Schluesssel inbegriffen			
MNL0645316	ERA16	1:2	12000	8Nm	-	X	CHUB19_SP3	CHUB32	CHTAER16ZC	CHESL10
MNL0645416	ERA16	1:2	12000	8Nm	P=70bar	X	CHUB19_SP3	CHUB32	CHTAER16ZC	CHESL10

DMG-MORI

NL1500/2000/2500/3000 12 STAZIONI - NLX1500/2000/2500/3000 12 STAZIONI - NLX4000 - NZL2000/2500 - NZX2500 (BMT60)
 NT4200/4250/4300/5400 - NTX2000/2500/3000 2ND GEN. 10ST. - CTX2500 (BMT60)

MODULO MOTORIZZATO ORIENTABILE +/-90° MOLTIPLICATO I=1:2 CON NONIO DIGITALE

+/-90° adjustable angle driven tool geared-up I=1:2 with digital display

Angetriebenes Werkzeug schwenkbar +/-90° uebersetzt I=1:2 mit digital display

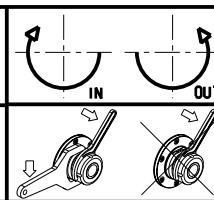

M.T. srl

Via Casino Albini 480
 Tel. 0541/956034-957884
 Fax 0541/956341
 47842 S. GIOVANNI IN M. (RN)
 e-mail: mtma@mtmarchetti.com
 http://www.mtmarchetti.com



PAGINA MNL336-1-01

Subject to change without notice.

10/2021

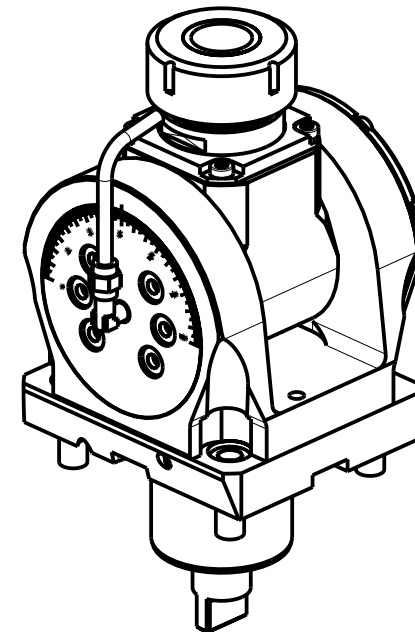
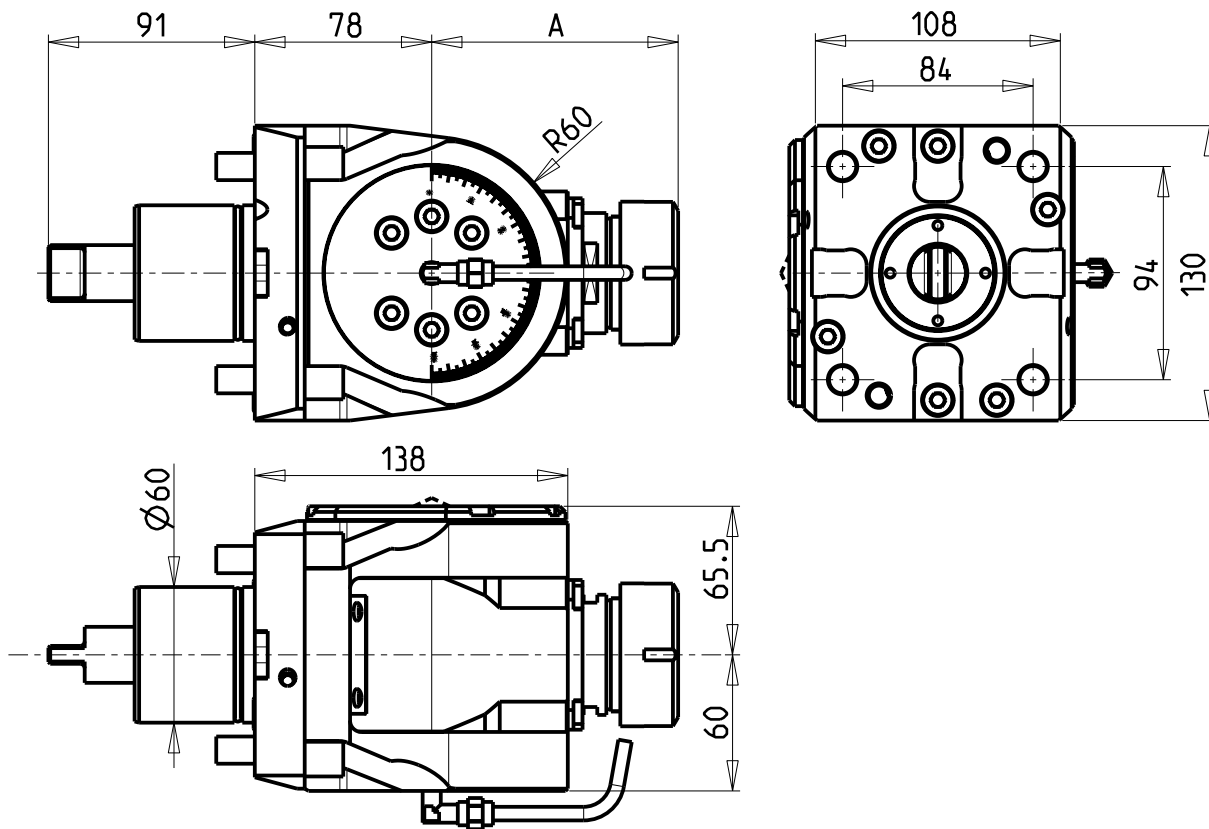

Cod. MT	Mandrino Spindle Spindel	I	RPM	Coppia Max Max Torque Max Drehmoment	Lubrificazione int. Coolant through Innenkuehlung	Lubrificazione est. Ext. coolant Aussenkuehlung	A	CHIAVI INCLUSE Keys included Schluessel inbegriffen				
								CHUB30	CHUB46	CHTAER32ZC	CHESL10	CHESL06
MNL0660332	ERA32	1:1	6000	50Nm	-	X	81	CHUB30	CHUB46	CHTAER32ZC	CHESL10	CHESL06
MNL0660432	ERA32	1:1	6000	50Nm	P=70bar	X	81	CHUB30	CHUB46	CHTAER32ZC	CHESL10	CHESL06
MNL0660140	ER40	1:1	6000	50Nm	-	X	108.66	-	CHUB46	CHSTER40	CHESL10	CHESL06
MNL0660240	ER40	1:1	6000	50Nm	P=70bar	X	108.66	-	CHUB46	CHSTER40	CHESL10	CHESL06

DMG-MORI

NL1500/2000/2500/3000 12 STAZIONI - NLX1500/2000/2500/3000 12 STAZIONI - NLX4000 - NZL2000/2500 - NZX2500 (BMT60)
 NT4200/4250/4300/5400 - NTX2000/2500/3000 2ND GEN. 10ST. - CTX2500 (BMT60)

MODULO MOTORIZZATO ORIENTABILE +/-90°

+/-90° adjustable angle driven tool

Angetriebenes Werkzeug schwenkbar +/-90°

Subject to change without notice.

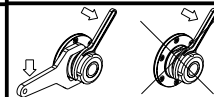

M.T. srl

Via Casino Albini 480
 Tel. 0541/956034-957884

Fax 0541/956341

47842 S. GIOVANNI IN M. (RN)

e-mail: mtma@mtmarchetti.com

http://www.mtmarchetti.com



PAGINA MNL339-1-00

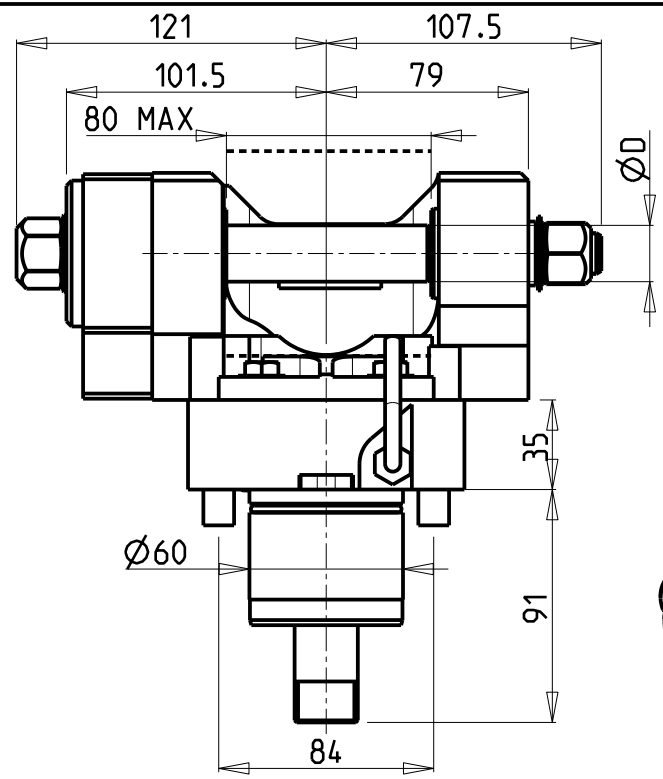
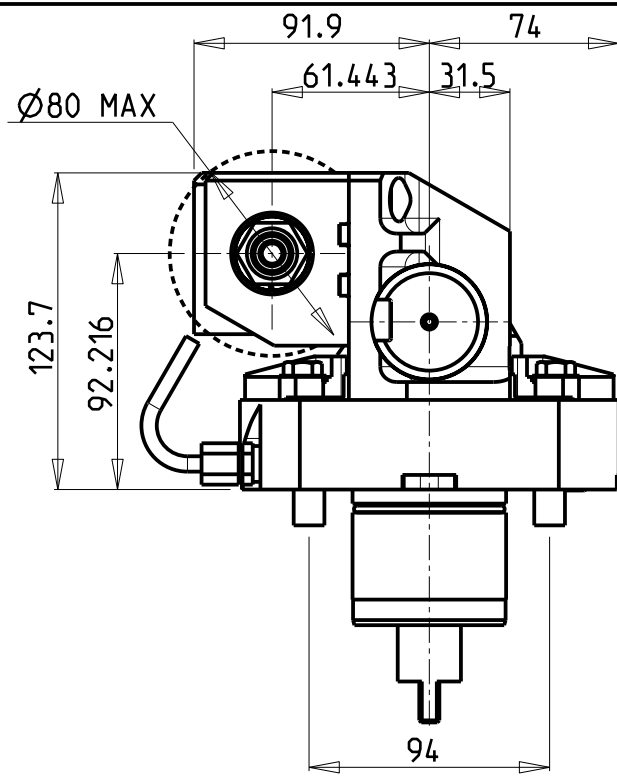

- SU RICHIESTA E' DISPONIBILE UNA STAFFA ANTIROTAZIONE PER LAVORAZIONI PESANTI
- On request we arrange antirotationscrew for heavy working
- Auf Anfrage verfuegen wir ueber Antirotationbolzen fuer schwere Verarbeitungen

INCLINAZIONE
REGOLABILE ±20°

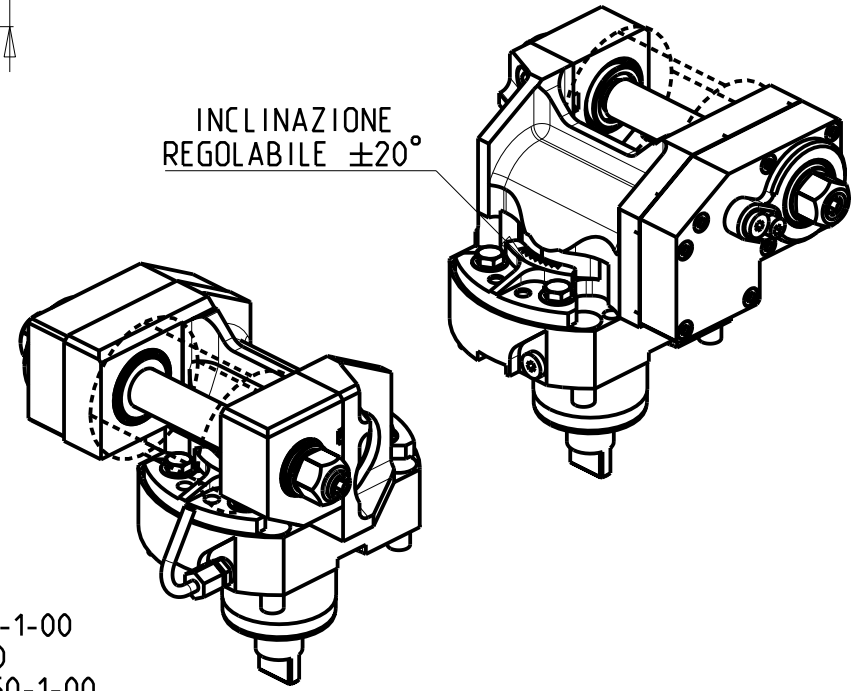

DOTAZIONI - SUPPLIED WITH - AUSSTATTUNG

- | | |
|-----------|---|
| mm / inch | - N°1 ALBERO + DISTANZIALI
- N°1 SHAFT + SPACER
- N°1 DORN + ABSTANDSSTUECK |
|-----------|---|

PER ALBERI E DISTANZIALI VEDI PAG. TBL250-1-00
FOR SHAFT END SPACER SEE PAGE TBL250-1-00
FUER DORN UND ABSTANDSSTUECK SEITE TBL250-1-00

Cod. MT	i	RPM max	Coppia Max Max Torque Max Drehmoment	Reversibile lato mandrino/contromandrino Reversible sub/main spindle side Umkehrbare Spindel-seite/ Gegenspindel-seite	Lubrificazione est. Ext. coolant Aussenkuehlung	D (mm)	D (Inch)	CHIAVI INCLUSE Keys included Schlüssel inbegriffen			
								CHUB24	CHUB13	CHESL08	CHESL10
MNL0151100	1:1	6000	60Nm	X	X	16-22-27-32	3/4"-1"-1 1/4"	CHUB24	CHUB13	CHESL08	CHESL10
MNL0152100	2:1	3000	80Nm	X	X	16-22-27-32	3/4"-1"-1 1/4"	CHUB24	CHUB13	CHESL08	CHESL10

DMG-MORI

NL1500/2000/2500/3000 12 STAZIONI - NLX1500/2000/2500/3000 12 STAZIONI - NLX4000 - NZL2000/2500 - NZX2500 (BMT60)
NT4200/4250/4300/5400 - NTX2000/2500/3000 2ND GEN. 10ST. - CTX2500 (BMT60)

MODULO MOTORIZZATO PORTACREATORE

Driven gear hobber
Angetriebenes Zahnradwaeltzraes-Werkzeug

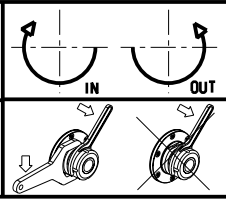

M.T. srl

Via Casino Albini 480
Tel. 0541/956034-957884
Fax 0541/956341
47842 S. GIOVANNI IN M. (RN)
e-mail: mtma@mtmarchetti.com
http://www.mtmarchetti.com



PAGINA MNL340-1-00

Subject to change without notice.

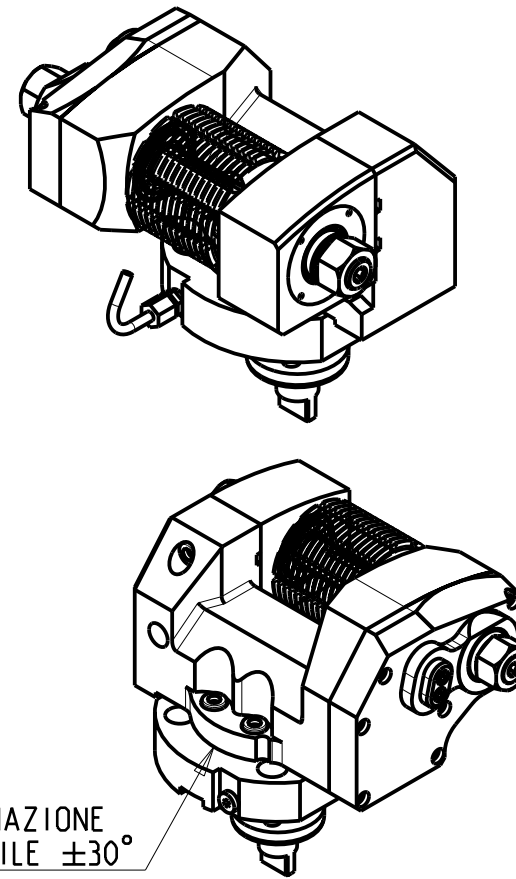
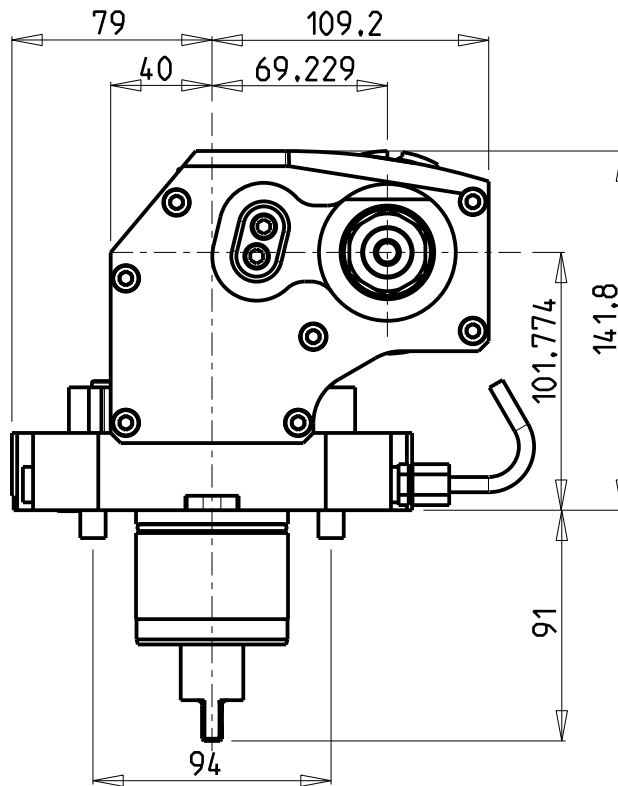
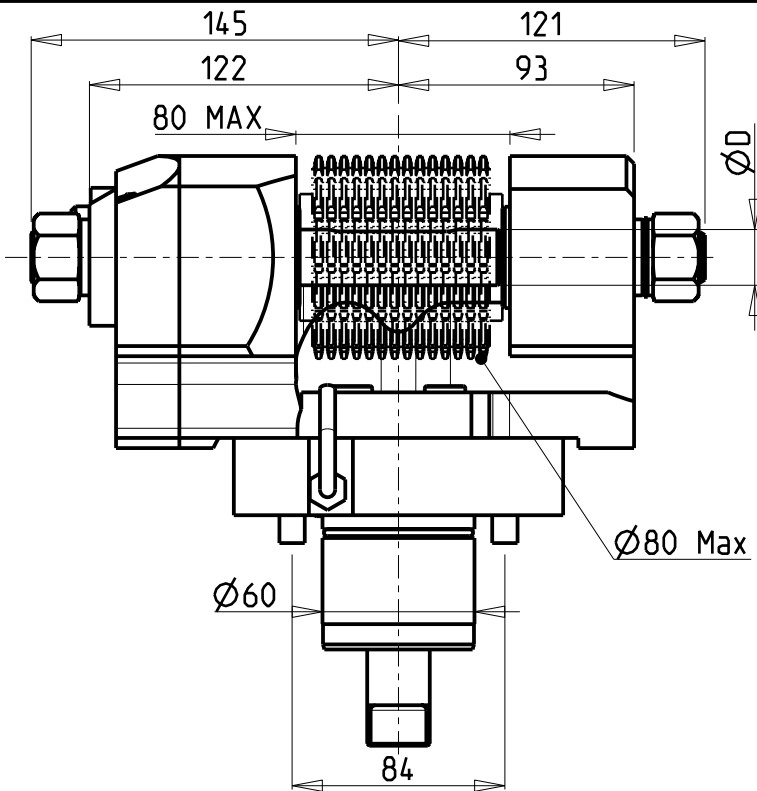

INCLINAZIONE
REGOLABILE ±30°

DOTAZIONI - SUPPLIED WITH - AUSSTATTUNG

- mm / inch
- N°1 ALBERO + DISTANZIALI
 - N°1 SHAFT + SPACER
 - N°1 DORN + ABSTANDSSTUECK

PER ALBERI E DISTANZIALI VEDI PAG. TBL250-1-00
FOR SHAFT END SPACER SEE PAGE TBL250-1-00
FUER DORN UND ABSTANDSSTUECK SEITE TBL250-1-00

Cod. MT	i	RPM max	Coppia Max Max Torque Max Drehmoment	Lubrificazione est. Ext. coolant Aussenkuehlung	D (mm)	D (Inch)	CHIAVI INCLUSE Keys included Schluessel inbegriffen			
							CHUB30	CHE8L08	CHE8L10	CHUB24 (Ø16 / Ø3/4")
MNL0411100	1:1	6000	90Nm	X	16-22-27-32	3/4"-1"-1 1/4"	CHUB30	CHE8L08	CHE8L10	CHUB24 (Ø16 / Ø3/4")
MNL0412100	2:1	3000	110Nm	X	16-22-27-32	3/4"-1"-1 1/4"	CHUB30	CHE8L08	CHE8L10	CHUB24 (Ø16 / Ø3/4")

DMG-MORI

NL1500/2000/2500/3000 12 STAZIONI - NLX1500/2000/2500/3000 12 STAZIONI - NLX4000 - NZL2000/2500 - NZX2500 (BMT60)
NT4200/4250/4300/5400 - NTX2000/2500/3000 2ND GEN. 10ST. - CTX2500 (BMT60)

MODULO MOTORIZZATO PORTACREATORE MAGGIORATO

Reinforced driven gear hobber

Angetriebenes Zahnradwaeltzraes-Werkzeug vergroessert

Subject to change without notice.

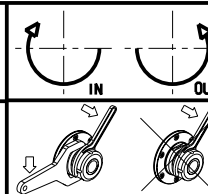

M.T. srl

Via Casino Albini 480
Tel. 0541/956034-957884
Fax 0541/956341
47842 S. GIOVANNI IN M. (RN)
e-mail: mtma@mtmarchetti.com
http://www.mtmarchetti.com



PAGINA MNL340-1-60

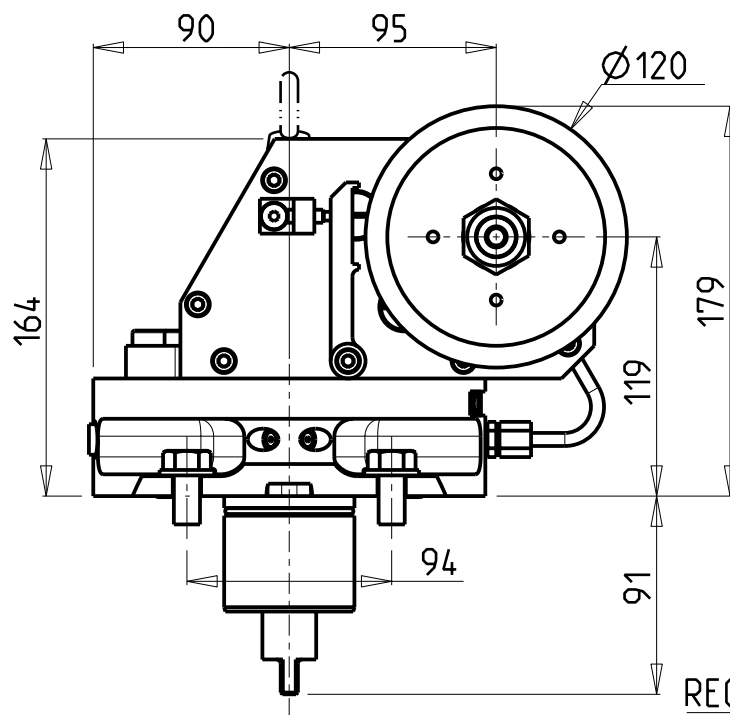
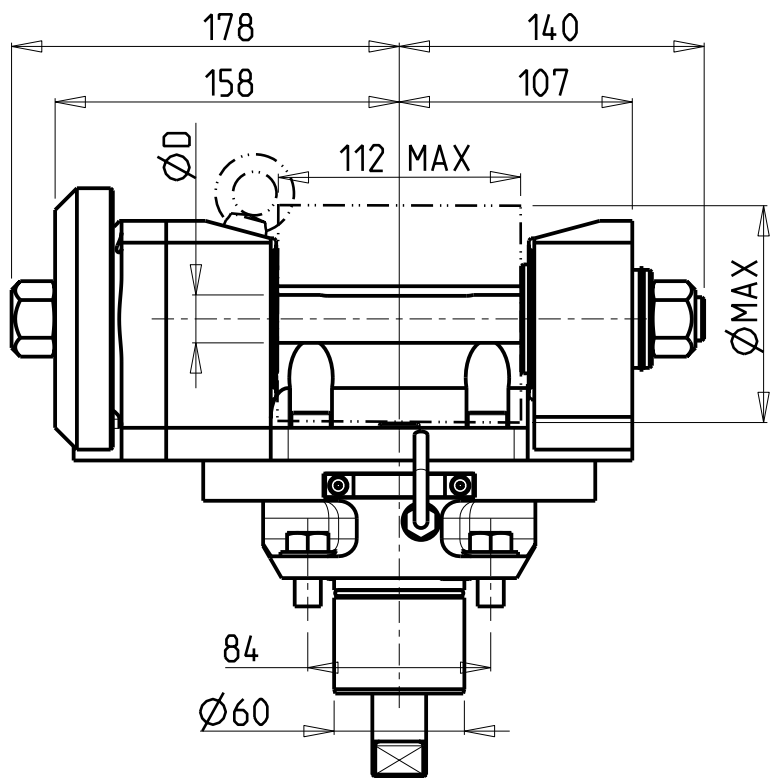

D (mm)	ØMAX (mm)
22	89
27-32	100

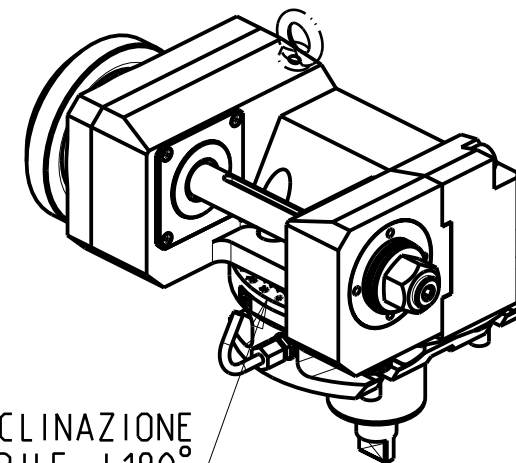

INCLINAZIONE
REGOLABILE ±180°

DOTAZIONI - SUPPLIED WITH - AUSSTATTUNG

- | mm / inch | |
|-----------|-----------------------------|
| | - N°1 ALBERO + DISTANZIALI |
| | - N°1 SHAFT + SPACER |
| | - N°1 DORN + ABSTANDSSTUECK |

PER ALBERI E DISTANZIALI VEDI PAG. TBL250-1-00
FOR SHAFT END SPACER SEE PAGE TBL250-1-00
FUER DORN UND ABSTANDSSTUECK SEITE TBL250-1-00

ATTENZIONE - ATTENTION - ACHTUNG

- VERIFICARE LE MISURE DI INGOMBRO PER POSSIBILE INTERFERENZA SU ALCUNI MODELLI DI MACCHINE
- Please check the overall sizes for possible interferences on some machine models
- Bitte überprüfen sie das ausmass um mögliche interferenzen auf einigen maschinen modellen zu vermeiden

Cod. MT	i	RPM max	Coppia Max Max Torque Max Drehmoment	Lubrificazione est. Ext. coolant Aussenkuehlung	D (mm)	CHIAVI INCLUSE Keys included Schlüssel inbegriffen			
						CHUB30	CHESL08	CHESL10	CHUB19
MNL0671100	1:1	6000	110Nm	X	22-27-32	CHUB30	CHESL08	CHESL10	CHUB19
MNL0672100	2:1	3000	130Nm	X	22-27-32	CHUB30	CHESL08	CHESL10	CHUB19

DMG-MORI

NL1500/2000/2500/3000 12 STAZIONI - NLX1500/2000/2500/3000 12 STAZIONI - NLX4000 - NZL2000/2500 - NZX2500 (BMT60)
NT4200/4250/4300/5400 - NTX2000/2500/3000 2ND GEN. 10ST. - CTX2500 (BMT60)

MODULO MOTORIZZATO PORTACREATORE (TAGLIA GRANDE)

Driven gear hobber (big size)

Angetriebenes Zahnradwaelzfraes-Werkzeug (grosse version)

Subject to change without notice.

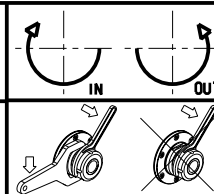

M.T. srl

Via Casino Albini 480
Tel. 0541/956034-957884
Fax 0541/956341
47842 S. GIOVANNI IN M. (RN)
e-mail: mtma@mtmarchetti.com
http://www.mtmarchetti.com



PAGINA MNL340-1-80

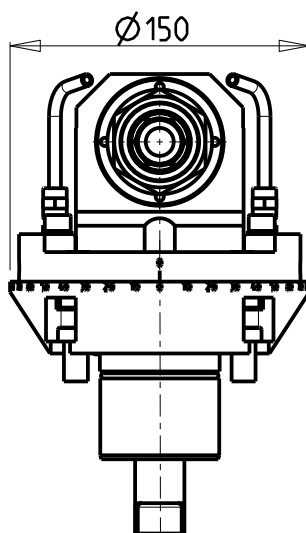
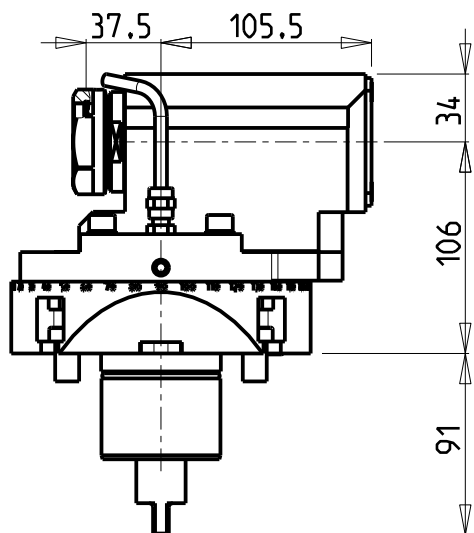
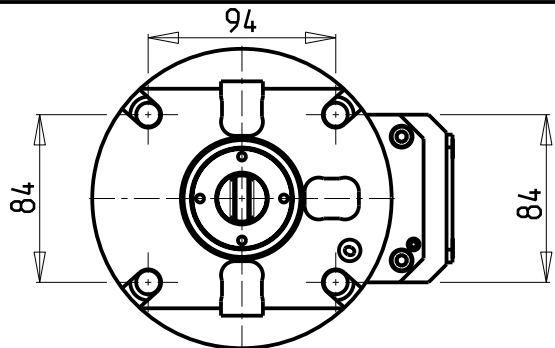

ATTENZIONE - ATTENTION - ACHTUNG

- VERIFICARE LE MISURE DI INGOMBRO PER POSSIBILE INTERFERENZA SU ALCUNI MODELLI DI MACCHINE
- Please check the overall sizes for possible interferences on some machine models
- Bitte überprüfen sie das ausmass um mögliche interferenzen auf einigen maschinen modellen zu vermeiden

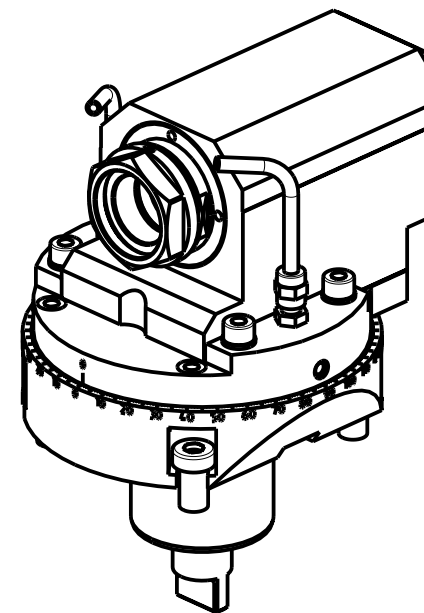

PER PORTAUTENSILI MODULARI MTSK-40 VEDI PAG. TBL300-1-40
 FOR MTSK-40 QUICK CHANGE TOOLHOLDERS CLAMPINGS SEE PAGE TBL300-1-40
 FUER MTSK-40 MODULARE WERKZEUGAUFNAHMEN SIEHE SEITE TBL300-1-40

Cod. MT	Mandrino Spindle Spindel	I	RPM	Coppia Max Max Torque Max Drehmoment	Lubr.esterna Ext. coolant Aussenkuehlung	CHIAVI INCLUSE Keys included Schluessel einbegriffen
MNL0870100	MTSK-40	1:1	6000	50Nm	X	n°2 CHUB46

DMG-MORI

NL1500/2000/2500/3000 12 STAZIONI - NLX1500/2000/2500/3000 12 STAZIONI - NLX4000 - NZL2000/2500 - NZX2500 (BMT60)
 NTX2000/2500/3000 2ND GEN. 10ST. - CTX2500 (BMT60)

MODULO MOTORIZZATO ASSIALE MTSK PER POWER SKIVING H=106mm

Axial MTSK driven tool for Power Skiving H=106mm

Axial MTSK angetriebenes Werkzeug fuer Power Skiving H=106mm

Subject to change without notice.

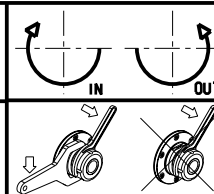

M.T. srl

Via Casino Albini 480
 Tel. 0541/956034-957884
 Fax 0541/956341
 47842 S. GIOVANNI IN M. (RN)
 e-mail: mtma@mtmarchetti.com
 http://www.mtmarchetti.com



PAGINA MNL350-1-00-K

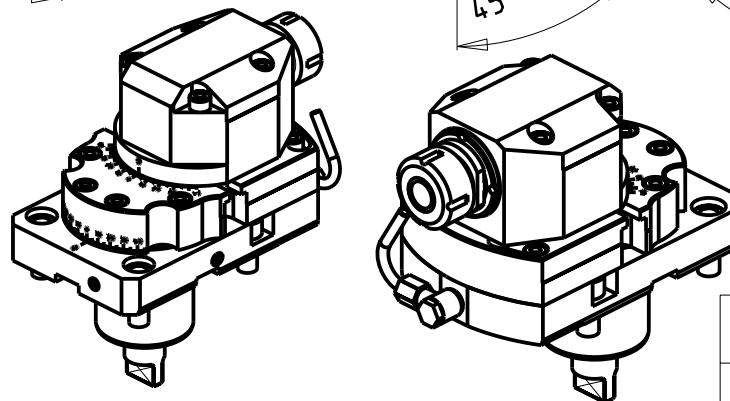
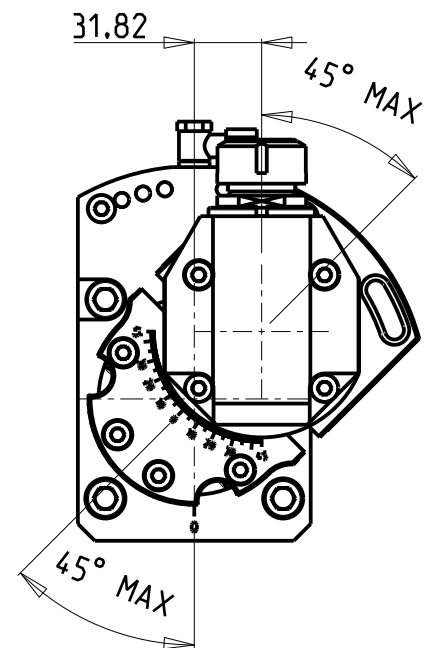
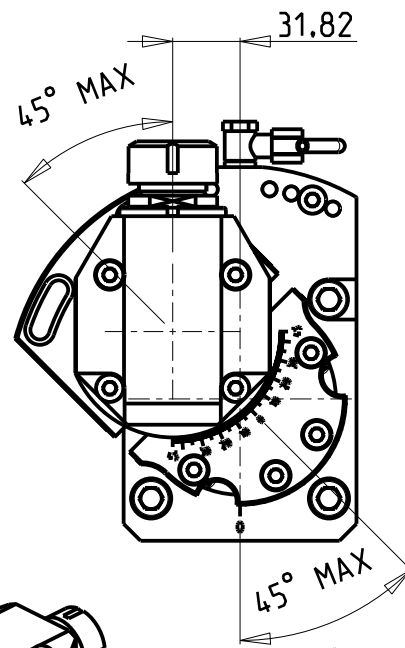
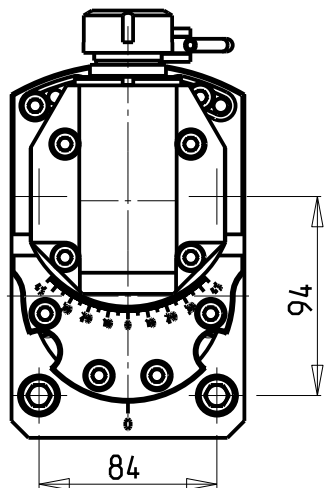
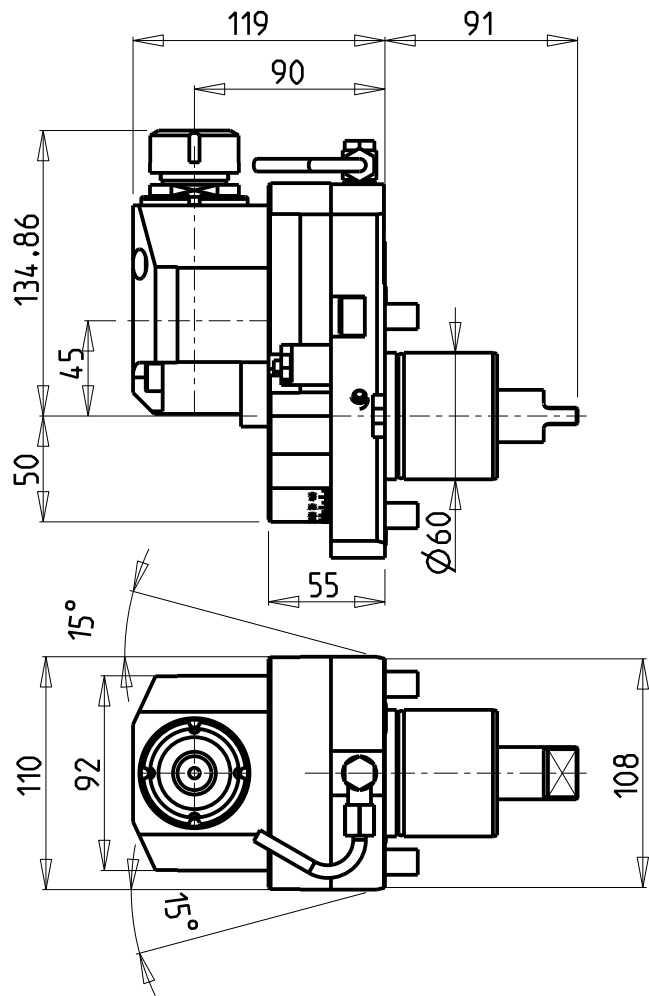

ATTENZIONE - ATTENTION - ACHTUNG

- VERIFICARE LE MISURE DI INGOMBRO PER POSSIBILE INTERFERENZA SU ALCUNI MODELLI DI MACCHINE
- Please check the overall sizes for possible interferences on some machine models
- Bitte überprüfen sie das ausmass um mögliche interferenzen auf einigen maschinen modellen zu vermeiden

Cod. MT	Mandrino Spindle Spindel	I	RPM	Coppia Max Max Torque Max Drehmoment	Reversibile lato mandrino/contromandrino Reversible sub/main spindle side Umkehrbare Spindel-seite/ Gegenspindel-seite	Lubrificazione est. Ext. coolant Aussenkuehlung	CHIAVI NON INCLUSE Keys not included Schlüssel nicht einbegriffen	
MNL1100125	ER25	1:1	6000	50Nm	X	X	CHSTER25	CHUB36

DMG-MORI

NL1500/2000/2500/3000 12 STAZIONI - NLX1500/2000/2500/3000 12 STAZIONI - NLX4000 - NZL2000/2500 - NZX2500 (BMT60)
 NT4200/4250/4300/5400 - NTX2000/2500/3000 2ND GEN. 10ST. - CTX2500 (BMT60)

MODULO MOTORIZZATO INCLINEVOLE $\pm 45^\circ$ IN Y
 $\pm 45^\circ$ Y axis adjustable angle driven tool
 Angetriebenes Werkzeug kippbar $\pm 45^\circ$ in Y

Subject to change without notice.

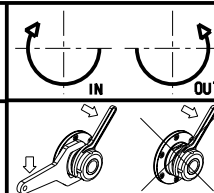

M.T. srl

Via Casino Albini 480
 Tel. 0541/956034-957884
 Fax 0541/956341
 47842 S. GIOVANNI IN M. (RN)
 e-mail: mtma@tmarchetti.com
 http://www.tmmarchetti.com



PAGINA MNL358-1-00

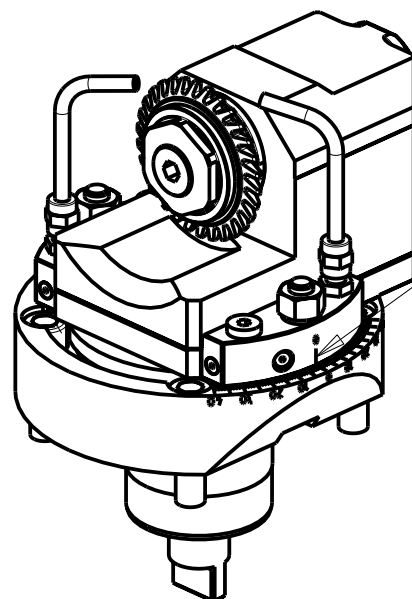
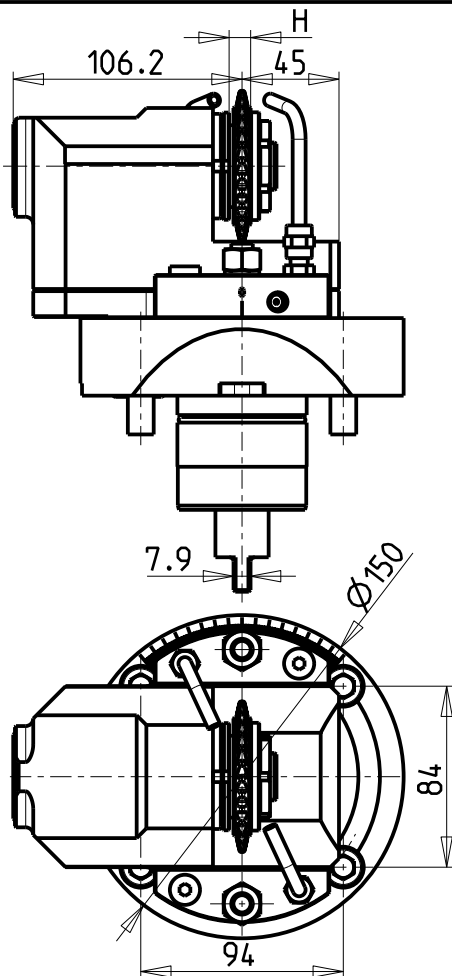
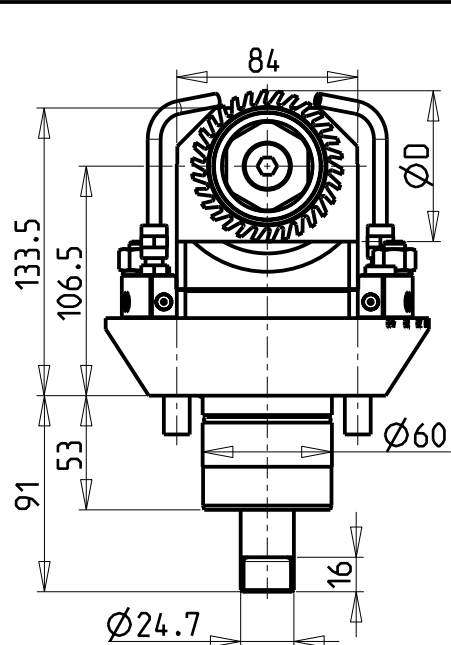

INCLINAZIONE
REGOLABILE $\pm 31^\circ$

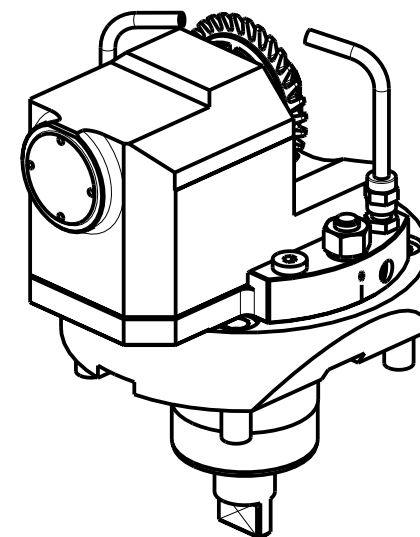

Cod. MT	Mandrino Spindle Spindel	I	RPM	Coppia Max Max Torque Max Drehmoment	Lubrificazione est. Ext. coolant Auslenkung	ØD	H	CHIAVI INCLUSE Keys included Schlüssel einbegriffen			
MNL0378022	Ø22x12	1:1	6000	50Nm	X	63-70-80	MAX 12	CHUB38	CHUB17	CHESL10	CHESL08
MNL0378125	Ø1"x12	1:1	6000	50Nm	X	63-70-80	MAX 12	CHUB38	CHUB17	CHESL10	CHESL08

DMG-MORI

NL1500/2000/2500/3000 12 STAZIONI - NLX1500/2000/2500/3000 12 STAZIONI - NLX4000 - NZL2000/2500 - NZX2500 (BMT60)
NT4200/4250/4300/5400 - NTX2000/2500/3000 2ND GEN. 10ST. - CTX2500 (BMT60)

MODULO MOTORIZZATO PER VITI SENZA FINE

Driven tool for worm screws

Angetriebenes Werkzeug fuer schrauben ohne ende

Subject to change without notice.

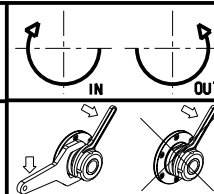

M.T. srl

Via Casino Albini 480
Tel. 0541/956034-957884
Fax 0541/956341

47842 S. GIOVANNI IN M. (RN)
e-mail: mtma@tmarchetti.com
http://www.tmmarchetti.com



PAGINA MNL359-1-00

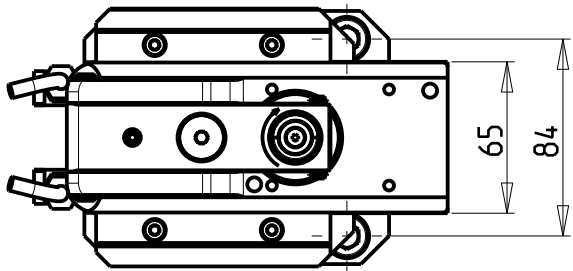
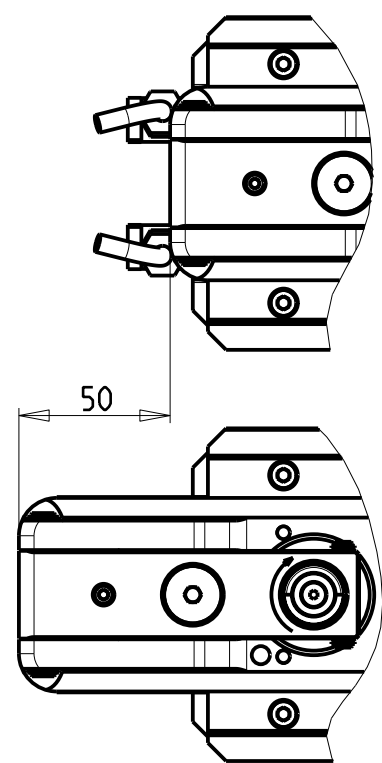
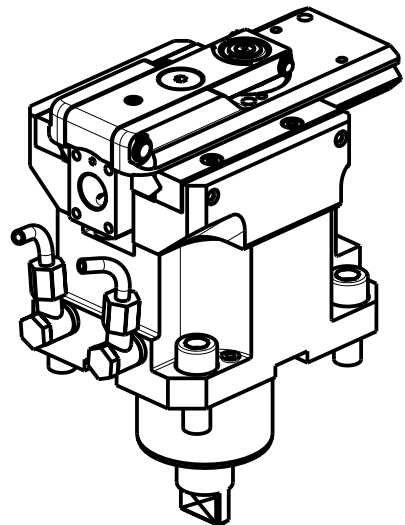
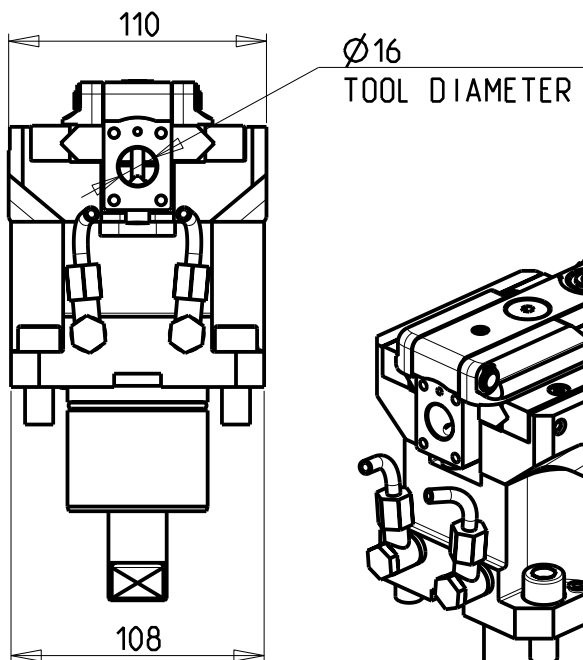
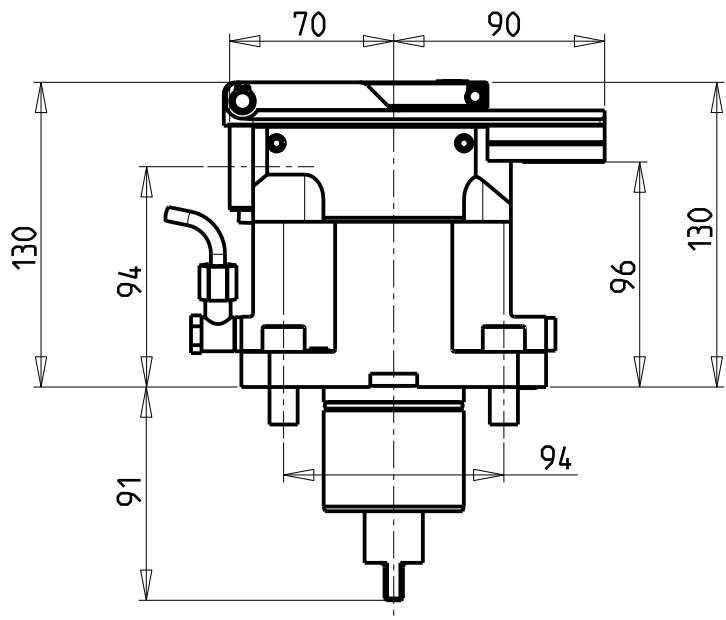

DOTAZIONI - SUPPLIED WITH - AUSSTATTUNG

N*1 Boccola di riduz. Ø16-Ø12 e N*1 Boccola di riduz. Ø16-Ø10
 N*1 Reduction bush Ø16-Ø12 and N*1 Reduction bush Ø16-Ø10
 N*1 Reduzierbuchsen Ø16-Ø12 und N*1 Reduzierbuchsen Ø16-Ø10

PER UTENSILI STOZZATORI VEDI PAG. TBL400-1-00
 FOR DRIVEN SLOTTING TOOL CUTTING-TOOLS SEE PAGE TBL400-1-00
 FÜR NUTENSTOSS-WERKZEUG SCHNEIDWERKZEUGE SIEHE SEITE TBL400-1-00

Cod. MT	I	RPM MAX	Reversibile lato mandrino/contromandrino Reversible sub/main spindle side Umkehrbare Spindelseite/ Gegenspindelseite	Lubr. esterna Ext. coolant Aussenkuehlung
MNL0650100	4:1	2000	X	X

DMG-MORI
 NL1500/2000/2500/3000 12 STAZIONI - NLX1500/2000/2500/3000 12 STAZIONI - NLX4000 - NZL2000/2500 - NZX2500 (BMT60)
 NT4200/4250/4300/5400 - NTX2000/2500/3000 2ND GEN. 10ST. - CTX2500 (BMT60)

MODULO MOTORIZZATO STOZZATORE CORSA 50mm H=94mm
 Slotting driven tool 50mm stroke H=94mm
 Keilnutenstossmaschine 50mm Hub H=94mm

M.T. srl
 Via Casino Albini 480
 Tel. 0541/956034-957884
 Fax 0541/956341
 47842 S. GIOVANNI IN M. (RN)
 e-mail: mtma@mtmarchetti.com
 http://www.mtmarchetti.com



PAGINA MNL360-1-00

Subject to change without notice.

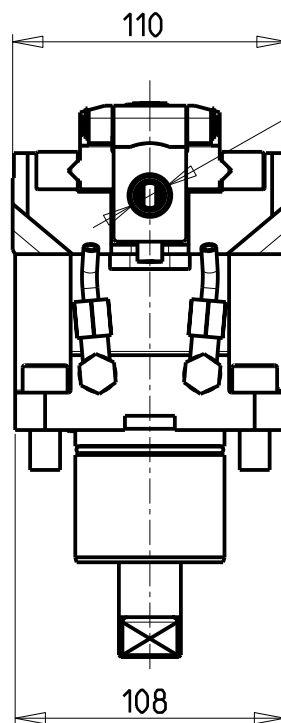
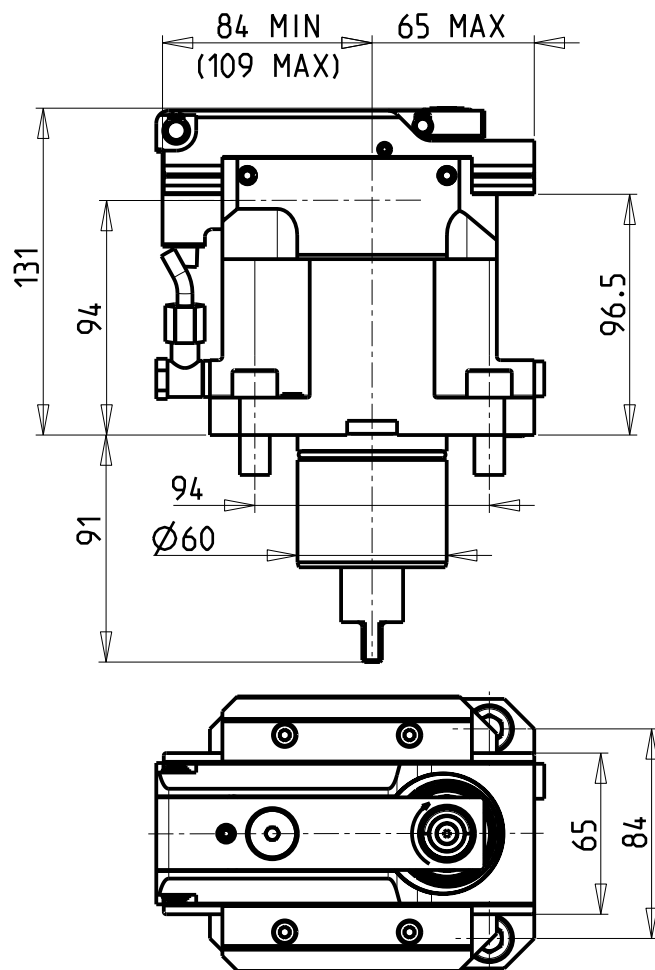

Ø16
TOOL DIAMETER

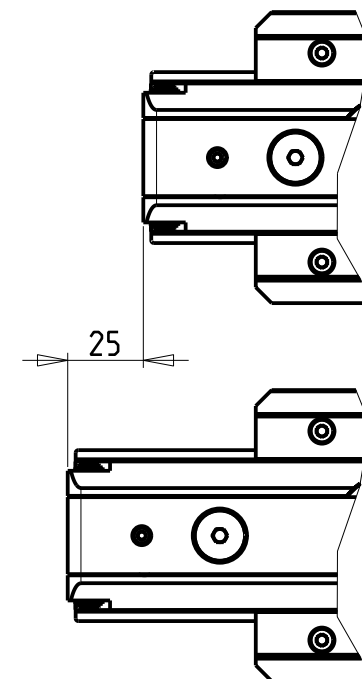
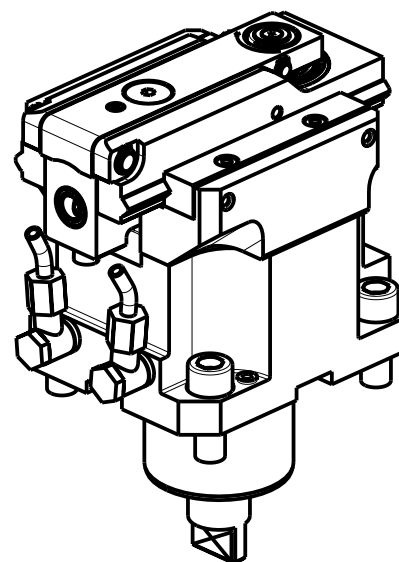

DOTAZIONI - SUPPLIED WITH - AUSSTATTUNG

N*1 Boccola di riduz. Ø16-Ø12 e N*1 Boccola di riduz. Ø16-Ø10
 N*1 Reduction bush Ø16-Ø12 and N*1 Reduction bush Ø16-Ø10
 N*1 Reduzierbuchsen Ø16-Ø12 und N*1 Reduzierbuchsen Ø16-Ø10

PER UTENSILI STOZZATORI VEDI PAG. TBL400-1-00
 FOR DRIVEN SLOTTING TOOL CUTTING-TOOLS SEE PAGE TBL400-1-00
 FÜR NUTENSTOSS-WERKZEUG SCHNEIDWERKZEUGE SIEHE SEITE TBL400-1-00

Cod. MT	I	RPM MAX	Reversibile lato mandrino/contromandrino Reversible sub/main spindle side Umkehrbare Spindelseite/ Gegenspindelseite	Lubr. esterna Ext. coolant Aussenkuehlung
MNL0650200	4:1	2400	X	X

DMG-MORI

NL1500/2000/2500/3000 12 STAZIONI - NLX1500/2000/2500/3000 12 STAZIONI - NLX4000 - NZL2000/2500 - NZX2500 (BMT60)
 NT4200/4250/4300/5400 - NTX2000/2500/3000 2ND GEN. 10ST. - CTX2500 (BMT60)

MODULO MOTORIZZATO STOZZATORE CORSA 25mm H=94mm

Slotting driven tool 25mm stroke H=94mm

Keilnutenstossmaschine 25mm Hub H=94mm

M.T. srl

Via Casino Albini 480
 Tel. 0541/956034-957884
 Fax 0541/956341
 47842 S. GIOVANNI IN M. (RN)
 e-mail: mtma@mtmarchetti.com
 http://www.mtmarchetti.com



PAGINA MNL360-1-01

Subject to change without notice.

10/2021

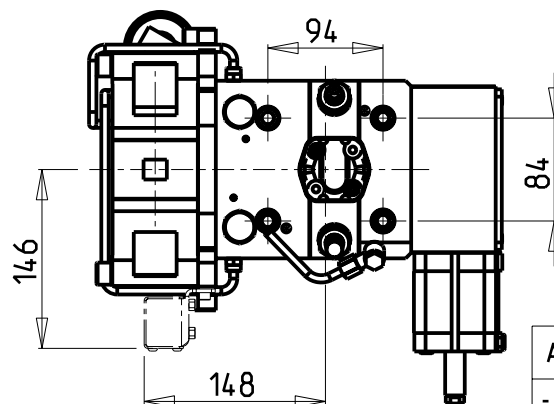
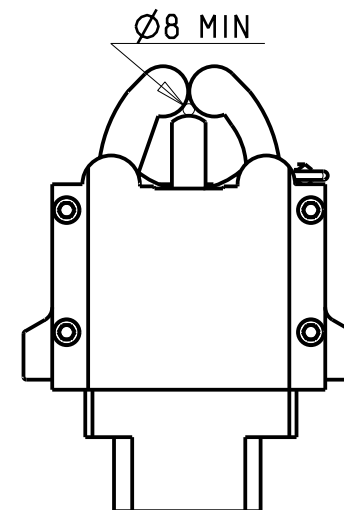
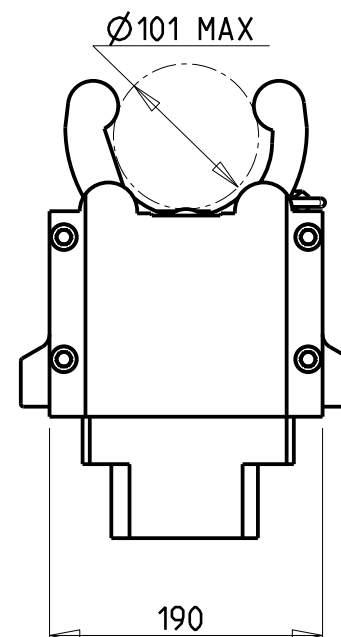
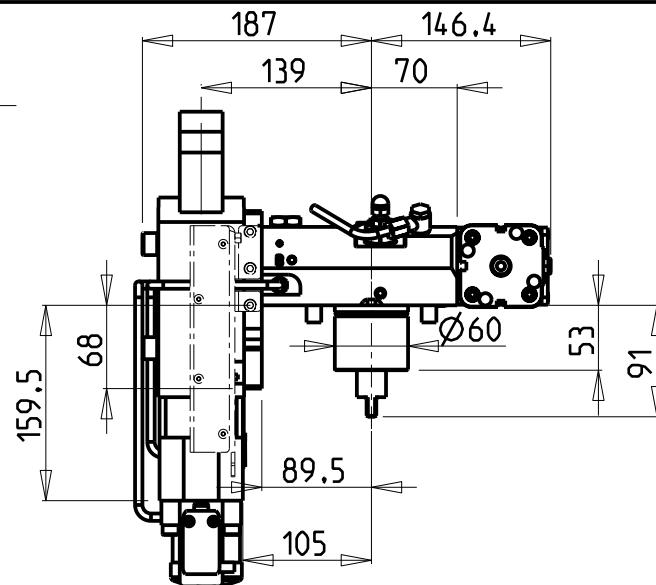
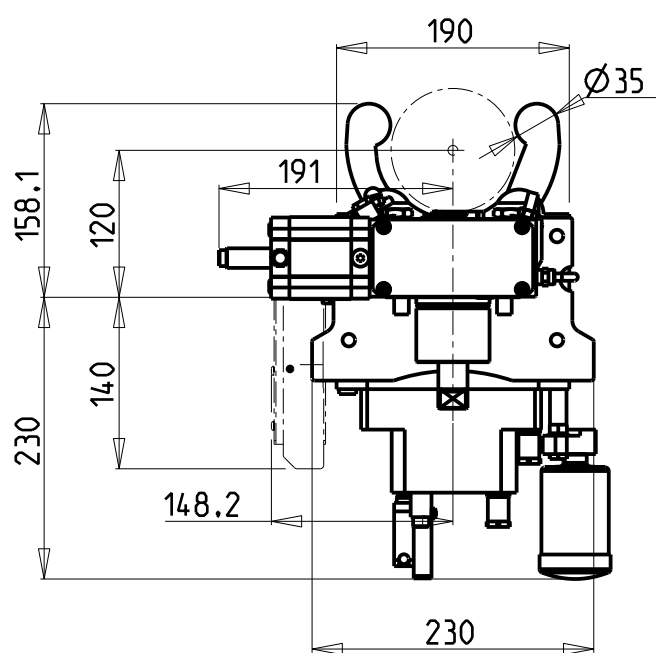

- # CON GESTIONE ELETTRONICA
APERTURA COMPLETA DELLA LUNETTA
- # With Electronic control of steady
rest arms complete opening
- # Mit vollständiger elektronischer
Öffnungsbedienung der Luenette

Cod. MT	I	RPM	Lubr. esterna Ext. coolant Aussenkuehlung	
MNL0560100	1:1	6000	X	
# MNL0560100EU	1:1	6000	X	EUROPE - AFRICA - MIDDLE EAST - NORTH ASIA
# MNL0560100US	1:1	6000	X	USA - CANADA - MEXICO - AUSTRALIA - SOUTH ASIA
# MNL0560100JP	1:1	6000	X	JAPAN

ATTENZIONE - ATTENTION - ACHTUNG

- VERIFICARE LE MISURE DI INGOMBRO PER POSSIBILE INTERFERENZA SU ALCUNI MODELLI DI MACCHINE
- Please check the overall sizes for possible interferences on some machine models
- Bitte überprüfen sie das ausmass um mögliche interferenzen auf einigen maschinen modellen zu vermeiden

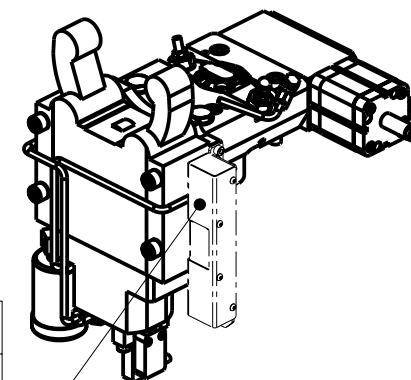

Only for
MNL0560100JP

DMG-MORI
NZL2000/2500 - NZX2500 (BMT60) - NT4200/4250/4300/5400

MODULO MOTORIZZATO PER LUNETTA (TAGLIA 2)
Steady rest driven tool (Size 2)
Angetriebenes werkzeug fuer Luenette (Grosses 2)

M.T. srl
Via Casino Albini 480
Tel. 0541/956034-957884
Fax 0541/956341
47842 S. GIOVANNI IN M. (RN)
e-mail: mtma@mtmarchetti.com
http://www.mtmarchetti.com



PAGINA MNL361-1-10

Subject to change without notice.

10/2021

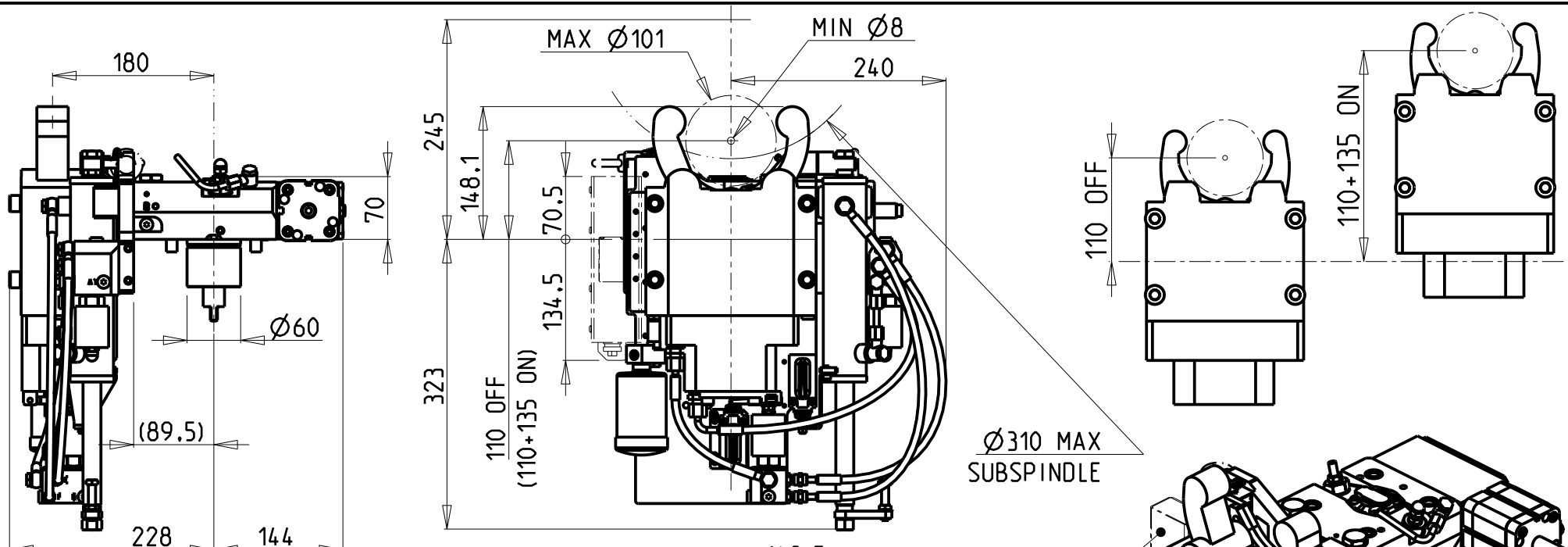

- # CON GESTIONE ELETTRONICA
APERTURA COMPLETA DELLA LUNETTA
- # With Electronic control of steady
rest arms complete opening
- # Mit vollständiger elektronischer
Öffnungsbedienung der Luenette

Cod. MT	I	RPM	Lubr. esterna Ext. coolant Aussenkuehlung	
MNL0560300	1:1	6000	X	
# MNL0560300EU	1:1	6000	X	EUROPE - AFRICA - MIDDLE EAST - NORTH ASIA
# MNL0560300US	1:1	6000	X	USA - CANADA - MEXICO - AUSTRALIA - SOUTH ASIA
# MNL0560300JP	1:1	6000	X	JAPAN

Only for
MNL0560300JP

DMG-MORI
NZL2000/2500 - NZX2500 (BMT60) - NT4200/4250/4300/5400

MODULO MOTORIZZATO PER LUNETTA RETRATTILE (TAGLIA 2)
Driven toolholder for sliding steady rest (Size 2)
Luenettenwerkzeug zurueck versetzte Version (Groesse 2)

M.T. srl
Via Casino Albini 480
Tel. 0541/956034-957884
Fax 0541/956341
47842 S. GIOVANNI IN M. (RN)
e-mail: mtma@tmarchetti.com
http://www.tmmarchetti.com



PAGINA MNL363-1-00

Subject to change without notice.

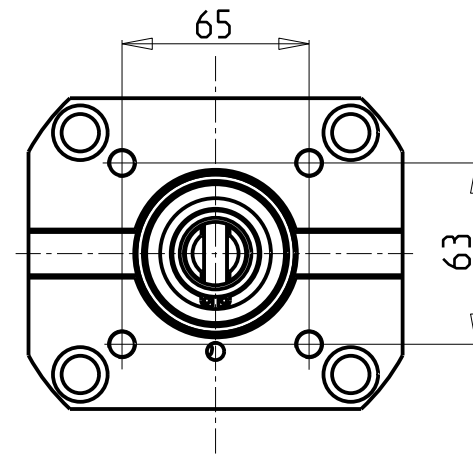
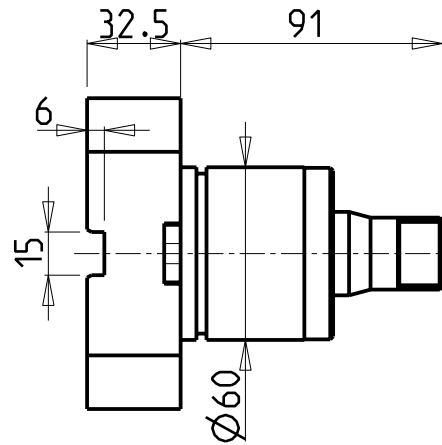
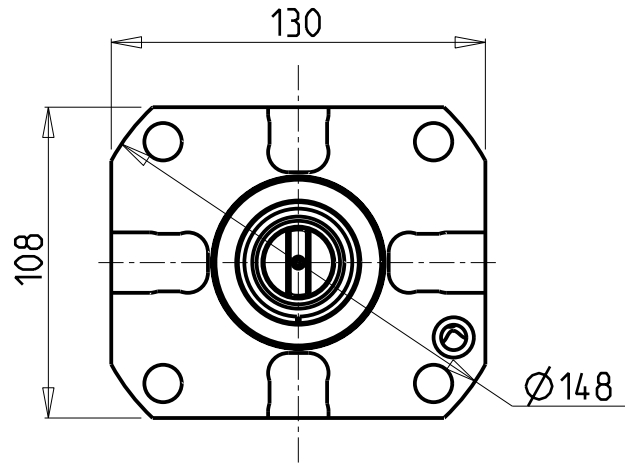
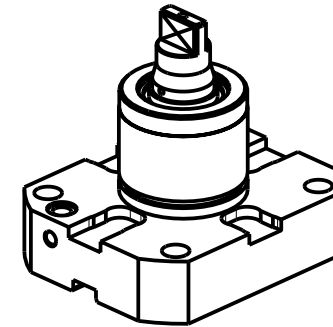
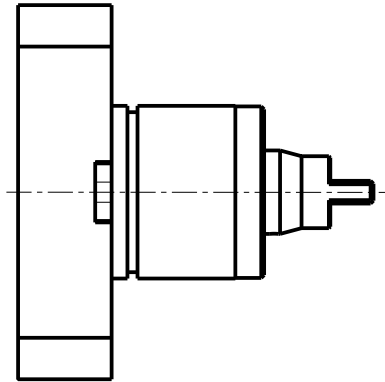
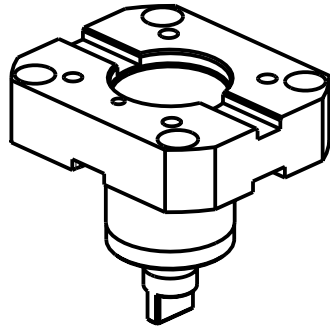

Cod. MT

MNL0246055

DMG-MORI

NL1500/2000/2500/3000 12 STAZIONI - NLX1500/2000/2500/3000 12 STAZIONI - NLX4000 - NZL2000/2500 - NZX2500 (BMT60)
 NT4200/4250/4300/5400 - NTX2000/2500/3000 2ND GEN. 10ST. - CTX2500 (BMT60)

INTERFACCIA PER MODULI BIGLIA

Biglia tooling adapter cartridge

Adapter-Patrone fuer Biglia Werkzeuge

Subject to change without notice.

M.T. srl

Via Casino Albini 480
 Tel. 0541/956034-957884
 Fax 0541/956341
 47842 S. GIOVANNI IN M. (RN)
 e-mail: mtma@mtmarchetti.com
 http://www.mtmarchetti.com



PAGINA MNL380-1-00

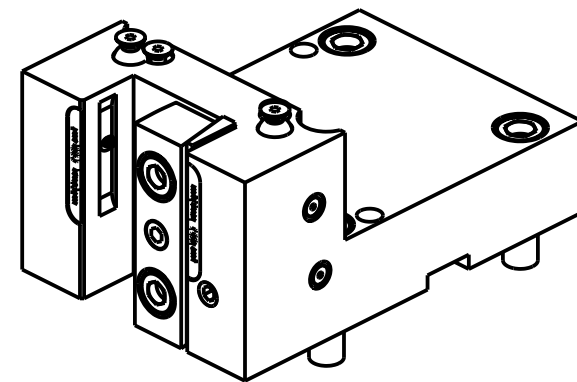
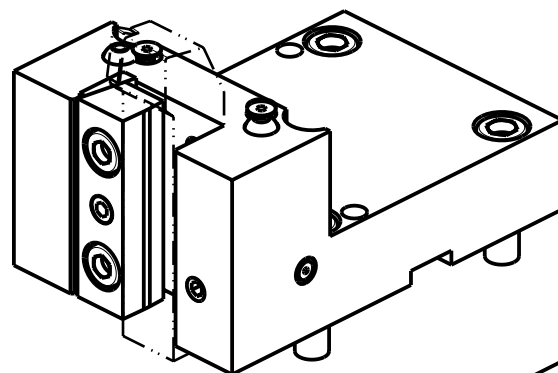
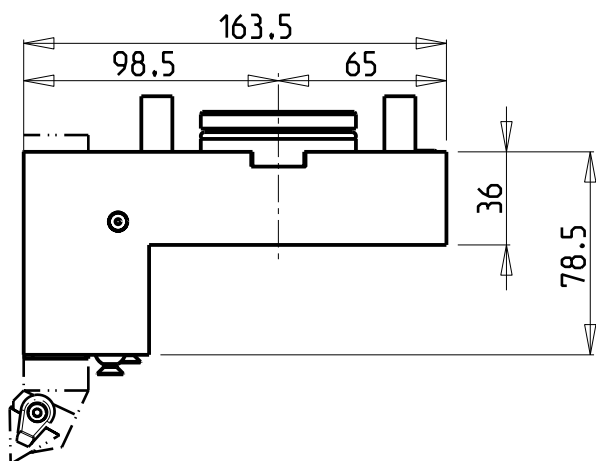
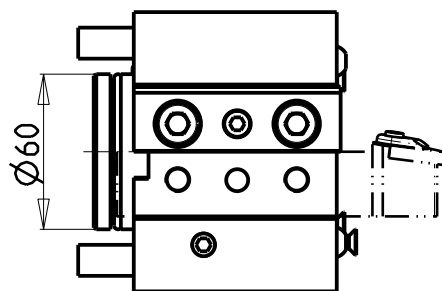
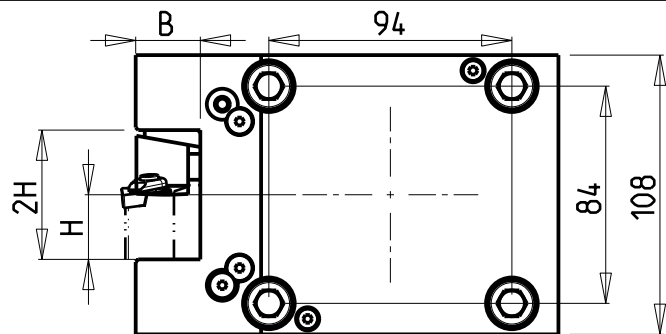

MNL0042510

Cod. MT	N°Utensili N°Tools N°Werkzeuge	Reversibile lato mandrino/contromandrino Reversible sub/main spindle side Umkehrbare Spindel-seite/ Gegenspindel-seite	Lubrificazione int. Coolant through Innenkuehlung	Lubrificazione est. Ext. coolant Aussenkuehlung	Misure Dimensions Masse	B	H
MNL0042500	1	X	-	X	mm	25	25
MNL0042510	1	X	P=70bar	X	mm	25	25
MNL0042540	1	X	-	X	Inch	1"	1"
MNL0042000	1	X	-	X	mm	20	20
MNL0041905	1	X	-	X	Inch	3/4"	3/4"

DMG-MORI

NL1500/2000/2500/3000 12 STAZIONI - NLX1500/2000/2500/3000 12 STAZIONI - NLX4000 - NZL2000/2500 - NZX2500 (BMT60)
 NT4200/4250/4300/5400 - NTX2000/2500/3000 2ND GEN. 10ST. - CTX2500 (BMT60)

PORTAUTENSILE RADIALE SINGOLO QD=25mm / QD=1" / QD=20mm / QD=3/4"

Radial single static tool QD=25mm / QD=1" / QD=20mm / QD=3/4"

Radial Single-Werkzeughalter QD=25mm / QD=1" / QD=20mm / QD=3/4"

Subject to change without notice.

M.T. srl

Via Casino Albini 480
 Tel. 0541/956034-957884
 Fax 0541/956341
 47842 S. GIOVANNI IN M. (RN)
 e-mail: mtma@tmarchetti.com
 http://www.tmmarchetti.com



PAGINA MNL423-1-00

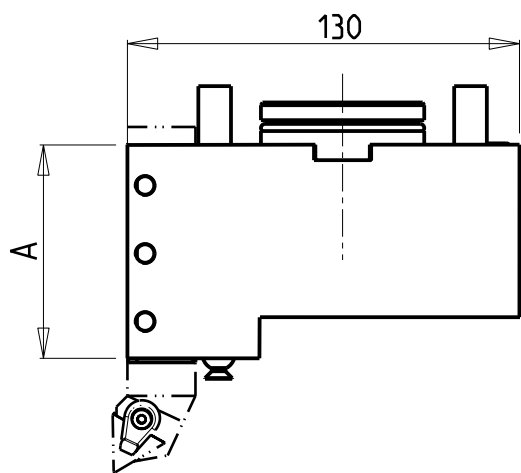
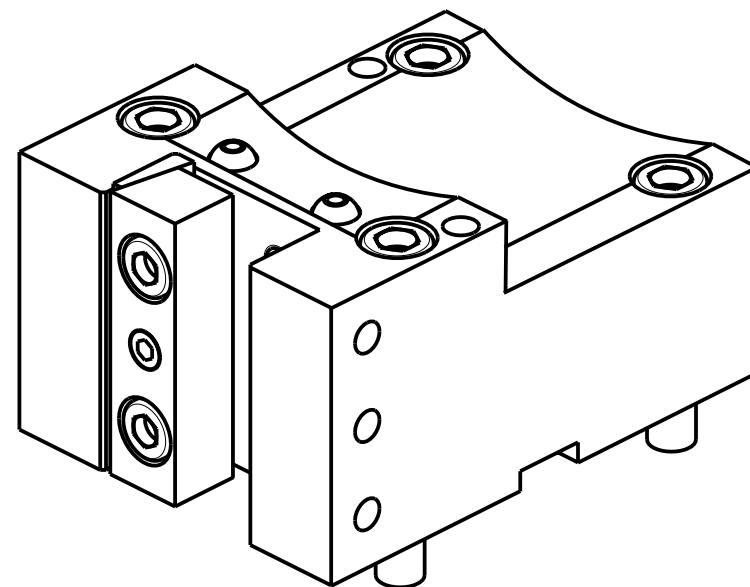
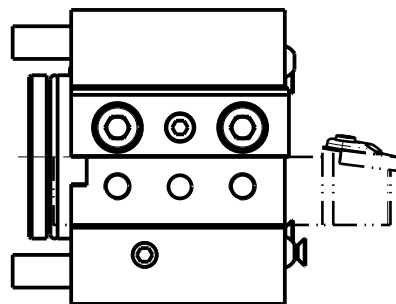
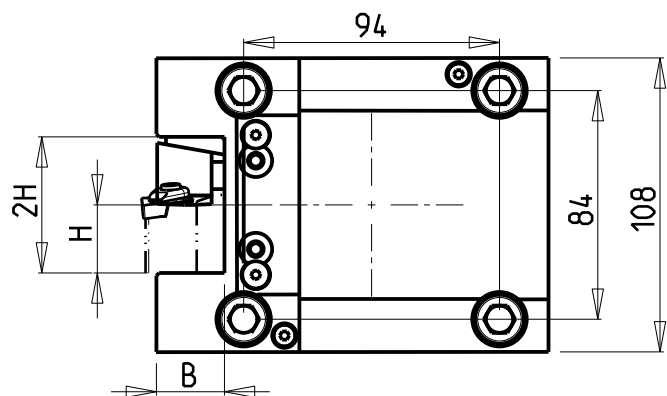

Cod. MT	Cod. MORI-SEIKI	N°Utensili N°Tools N°Werkzeuge	Misure Dimensions Masse	A	B	H
MNL0042500_CH	T00186	1/2	mm	70	25	25
MNL0042000_CH	T00187	1/2	mm	65	20	20

DMG-MORI

NL1500/2000/2500/3000 12 STAZIONI - NLX1500/2000/2500/3000 12 STAZIONI - NLX4000 - NZL2000/2500 - NZX2500 (BMT60)
 NT4200/4250/4300/5400 - NTX2000/2500/3000 2ND GEN. 10ST. - CTX2500 (BMT60)

PORTAUTENSILE RADIALE SINGOLO QD=25mm / QD=20mm

Radial single static tool QD=25mm / QD=20mm

Radial Single-Werkzeughalter QD=25mm / QD=20mm

Subject to change without notice.

M.T. srl

Via Casino Albini 480
 Tel. 0541/956034-957884
 Fax 0541/956341

47842 S. GIOVANNI IN M. (RN)
 e-mail: mtma@mtmarchetti.com
 http://www.mtmarchetti.com



PAGINA MNL424-1-00

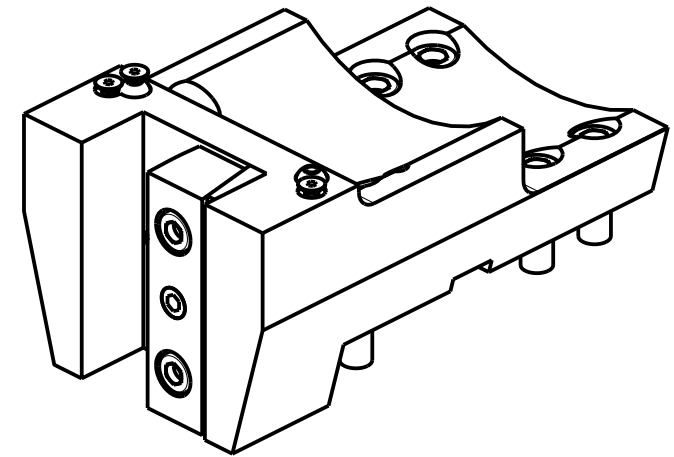
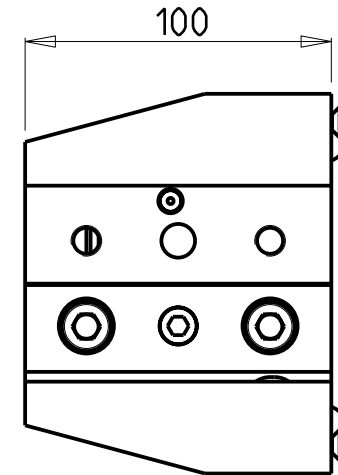
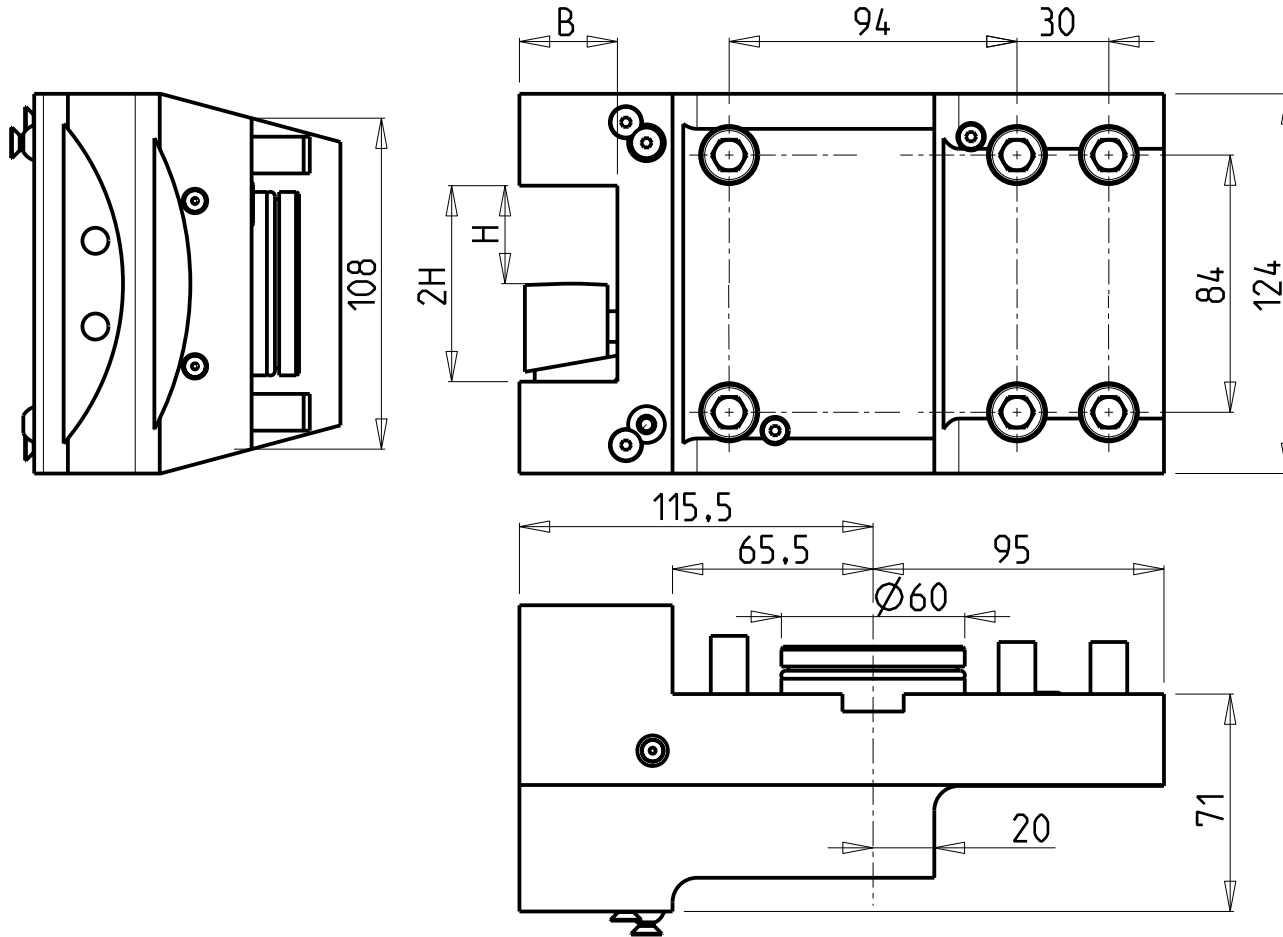

Cod. MT	Cod. MORI-SEIKI	N°Utensili N°Tools N°Werkzeuge	Misure Dimensioni Masse	B	H
MNL0043200	T00450	1	mm	32	32
MNL0043175	T00462	1	Inch	1 1/4"	1 1/4"

DMG-MORI
NLX2500 - NLX3000 - NLX4000 - CTX2500 (BMT60)

PORTAUTENSILE RADIALE SINGOLO QD=32mm / QD=1 1/4"
Radial single static tool QD=32mm / QD=1 1/4"
Radial Single-Werkzeughalter QD=32mm / QD=1 1/4"

Subject to change without notice.

M.T. srl

Via Casino Albini 480
Tel. 0541/956034-957884
Fax 0541/956341
47842 S. GIOVANNI IN M. (RN)
e-mail: mtma@mtmarchetti.com
<http://www.mtmarchetti.com>



PAGINA MNL426-1-00

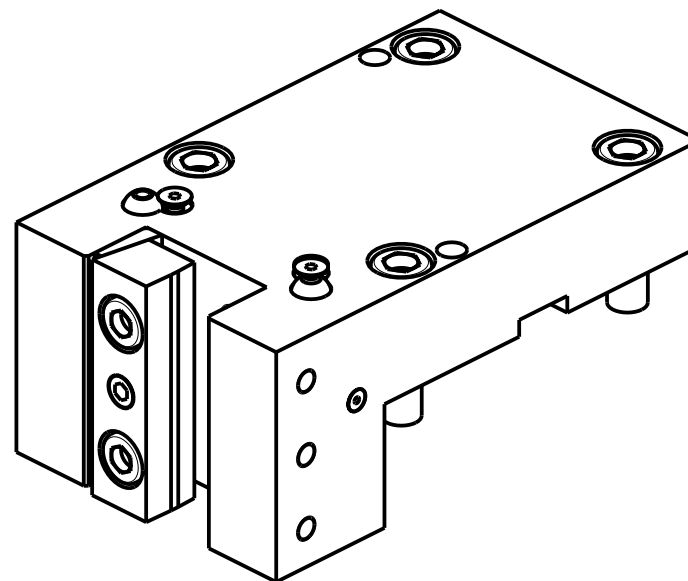
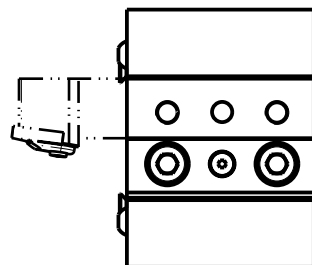
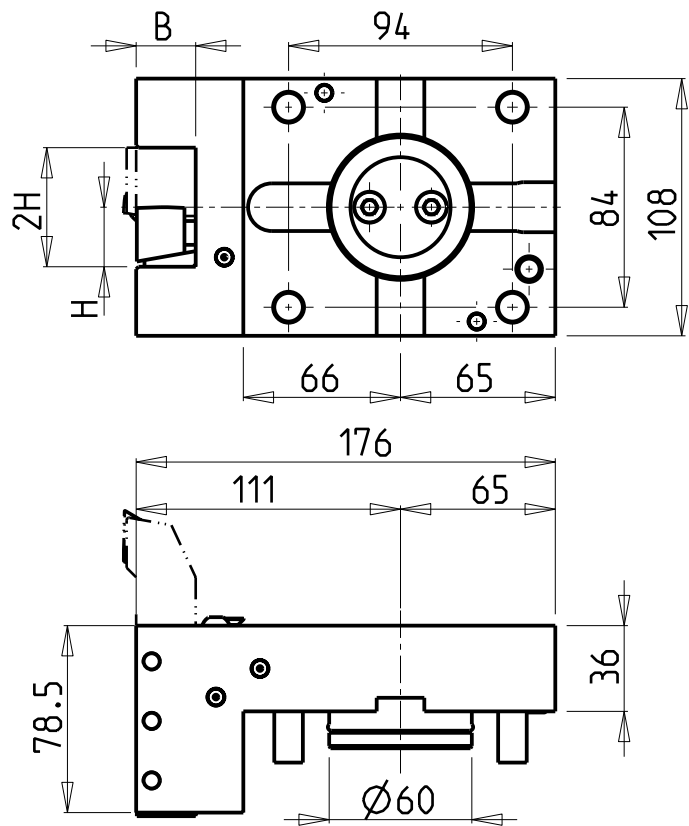

Cod. MT	N°Utensili N° Tools N° Werkzeuge	Misure Dimensions Masse	B	H
MNL0382500	1/2	mm	25	25
MNL0382540	1/2	Inch	1"	1"
MNL0382000	1/2	mm	20	20
MNL0381905	1/2	Inch	3/4"	3/4"

DMG-MORI

NL1500/2000/2500/3000 12 STAZIONI - NLX1500/2000/2500/3000 12 STAZIONI - NLX4000 - NZL2000/2500 - NZX2500 (BMT60)
 NT4200/4250/4300/5400 - CTX2500 (BMT60)

PORTAUTENSILE RADIALE SINGOLO ARRETRATO QD=25mm / QD=1" / QD=20mm / QD=3/4"

Radial rear-set single static tool QD=25mm / QD=1" / QD=20mm / QD=3/4"

Radial Single-Werkzeughalter zurueckversetzt QD=25mm / QD=1" / QD=20mm / QD=3/4"

Subject to change without notice.

M.T. srl

Via Casino Albini 480
 Tel. 0541/956034-957884
 Fax 0541/956341

47842 S. GIOVANNI IN M. (RN)
 e-mail: mtma@mtmarchetti.com
 http://www.mtmarchetti.com



PAGINA MNL433-1-00

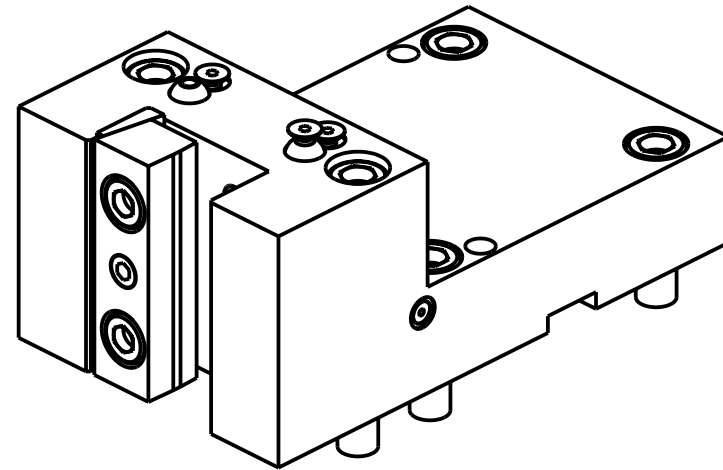
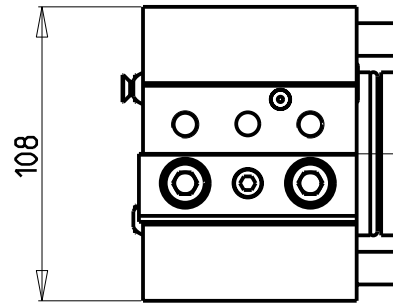
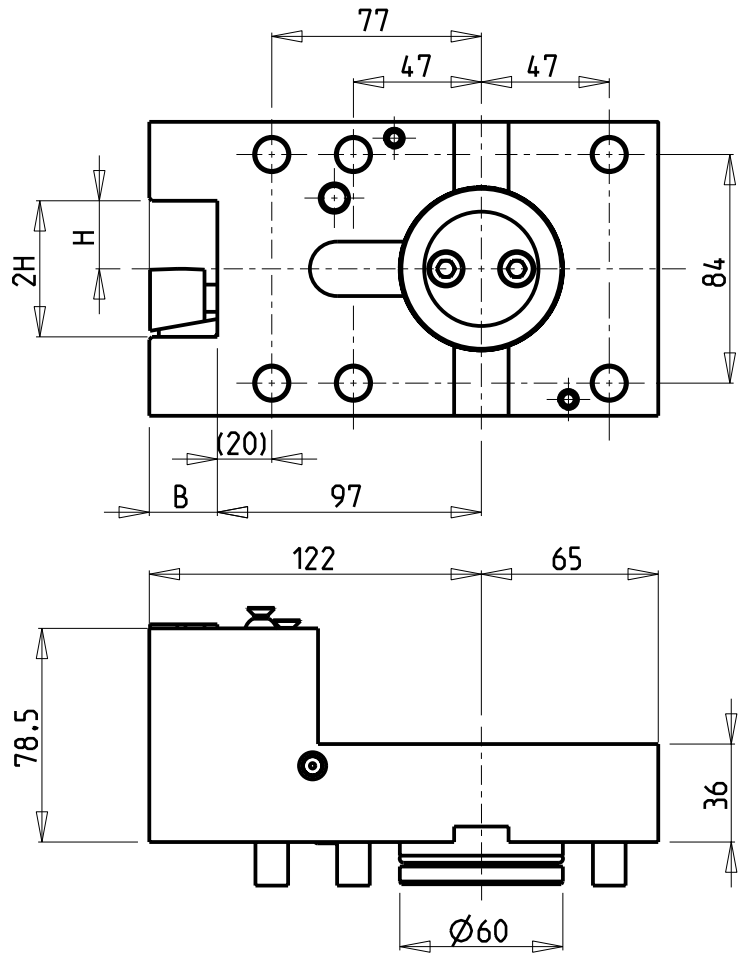

Cod. MT	Misure Dimensions Masse	B	H
MNL0992500	mm	25	25

DMG-MORI
NLX2500 - NLX3000 - NLX4000 - CTX2500 (BMT60)

PORTAUTENSILE RADIALE SINGOLO PER CONTROMANDRINO QD=25mm
Radial single static tool for subspindle QD=25mm
Radial Single-Werkzeughalter fuer Gegenspindel QD=25mm

Subject to change without notice.

M.T. srl
Via Casino Albini 480
Tel. 0541/956034-957884
Fax 0541/956341
47842 S. GIOVANNI IN M. (RN)
e-mail: mtma@mtmarchetti.com
<http://www.mtmarchetti.com>



PAGINA MNL436-1-00

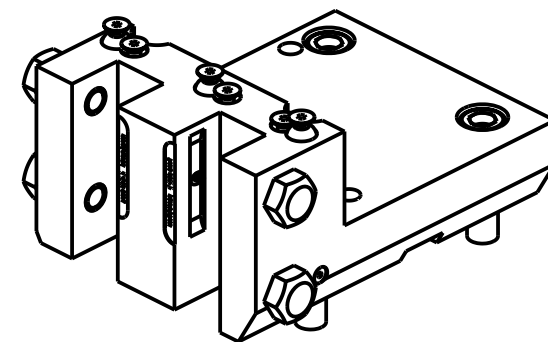
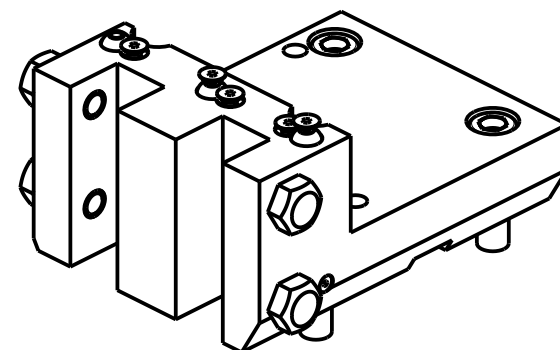
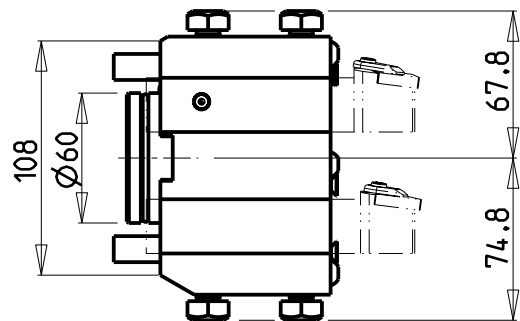
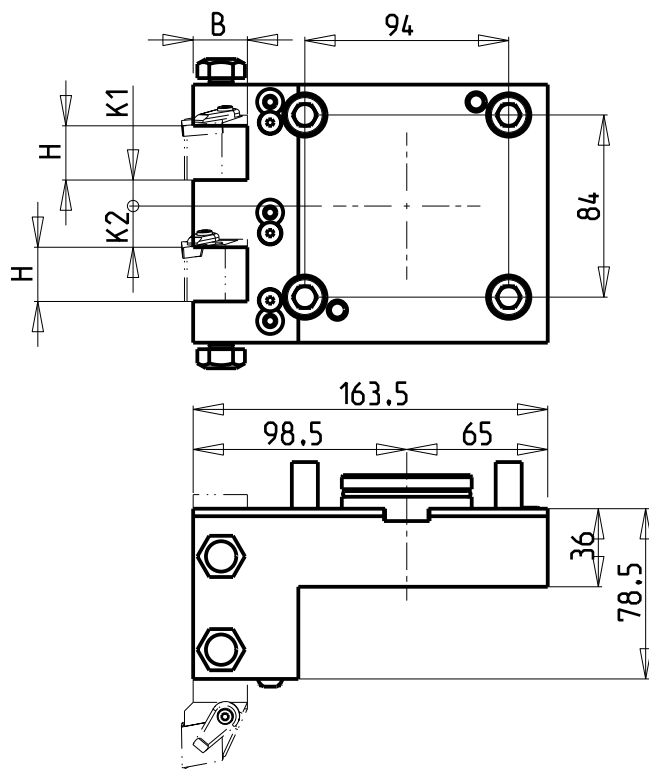

MNL0062510

Cod. MT	N°Utensili N°Tools N°Werkzeuge	Reversibile lato mandrino/contromandrino Reversible sub/main spindle side Umkehrbare Spindel-seite/ Gegenspindel-seite	Lubrificazione int. Coolant through Innenkuehlung	Lubrificazione est. Ext. coolant Aussenkuehlung	Misure Dimensions Masse	H	B	K1	K2
MNL0062500	2	X	-	X	mm	25	25	12	19
MNL0062540	2	X	-	X	Inch	1"	1"	1/2"	3/4"
MNL0062000	2	X	-	X	mm	20	20	12	19
MNL0061905	2	X	-	X	Inch	3/4"	3/4"	1/2"	3/4"
MNL0062510	2	X	P=70bar	X	mm	25	25	12	19

DMG-MORI

NL1500/2000/2500/3000 12 STAZIONI - NLX1500/2000/2500/3000 12 STAZIONI - NLX4000 - NZL2000/2500 - NZX2500 (BMT60)
NT4200/4250/4300/5400 - CTX2500 (BMT60)

PORTAUTENSILE RADIALE SOVRAPPOSTO QD=25mm / QD=1" / QD=20mm / QD=3/4"

Radial single side twin static tool QD=25mm / QD=1" / QD=20mm / QD=3/4"

Radial Werkzeughalter ueberlagert QD=25mm / QD=1" / QD=20mm / QD=3/4"

Subject to change without notice.

M.T. srl

Via Casino Albini 480
Tel. 0541/956034-957884
Fax 0541/956341
47842 S. GIOVANNI IN M. (RN)
e-mail: mtma@mtmarchetti.com
http://www.mtmarchetti.com



PAGINA MNL442-1-00

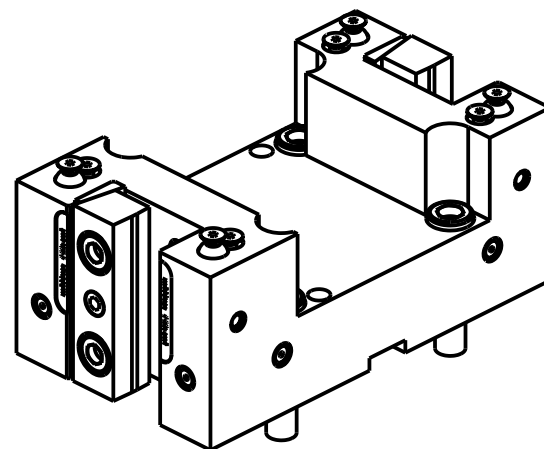
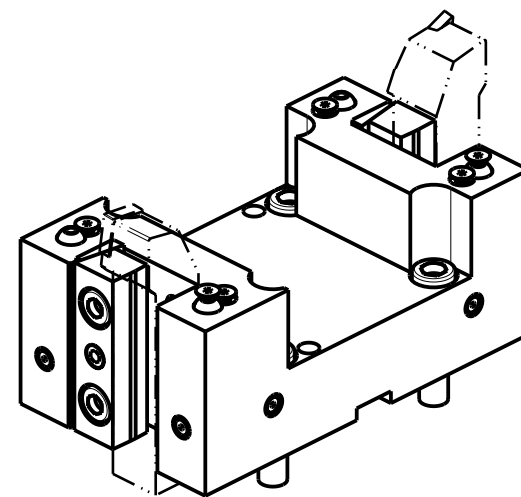
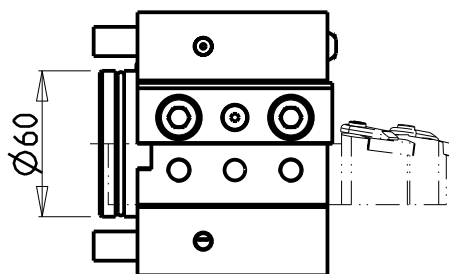
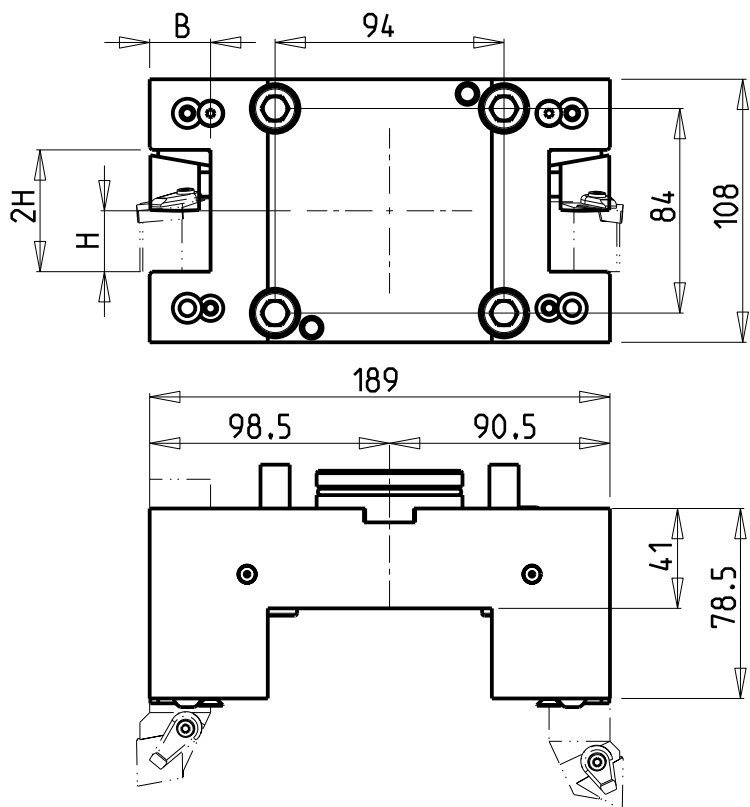

MNL0052510

Cod. MT	Cod. MORI-SEIKI	N°Utensili N°Tools N°Werkzeuge	Reversibile lato mandrino/contromandrino Reversible sub/main spindle side Umkehrbare Spindel-seite/ Gegenspindel-seite	Lubrificazione int. Coolant through Innenkuehlung	Lubrificazione est. Ext. coolant Aussenkuehlung	Misure Dimensions Masse	B	H
MNL0052500	T00184	2/4	X	-	X	mm	25	25
MNL0052510	-	2/4	X	P=70bar	X	mm	25	25
MNL0052540	T00199	2/4	X	-	X	Inch	1"	1"
MNL0052000	T00185	2/4	X	-	X	mm	20	20
MNL0051905	T00201	2/4	X	-	X	Inch	3/4"	3/4"

DMG-MORI

NL1500/2000/2500/3000 12 STAZIONI - NLX1500/2000/2500/3000 12 STAZIONI - NLX4000 - NZL2000/2500 - NZX2500 (BMT60)
NT4200/4250/4300/5400 - NTX2000/2500/3000 2ND GEN. 10ST. - CTX2500 (BMT60)

PORTAUTENSILE RADIALE DOPPIO QD=25mm / QD=1" / QD=20mm / QD=3/4"

Radial double static tool QD=25mm / QD=1" / QD=20mm / QD=3/4"

Radial Doppel-Werkzeughalter QD=25mm / QD=1" / QD=20mm / QD=3/4"

Subject to change without notice.

M.T. srl

Via Casino Albini 480
Tel. 0541/956034-957884
Fax 0541/956341

47842 S. GIOVANNI IN M. (RN)
e-mail: mtma@mtmarchetti.com
http://www.mtmarchetti.com



PAGINA MNL453-1-00

10/2021

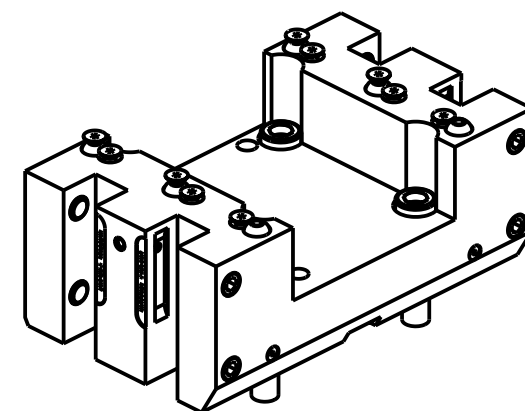
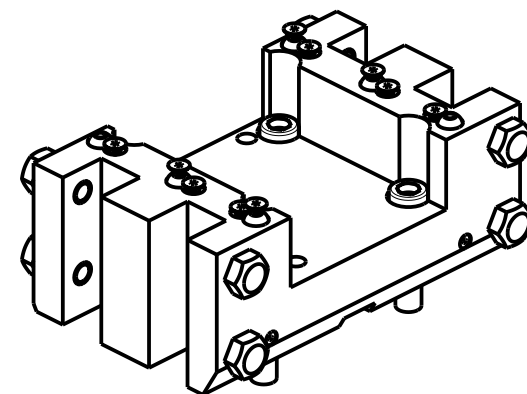
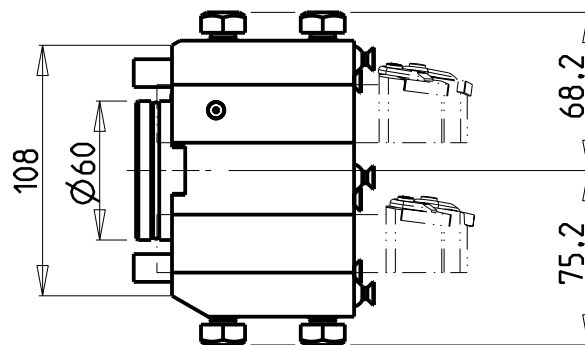
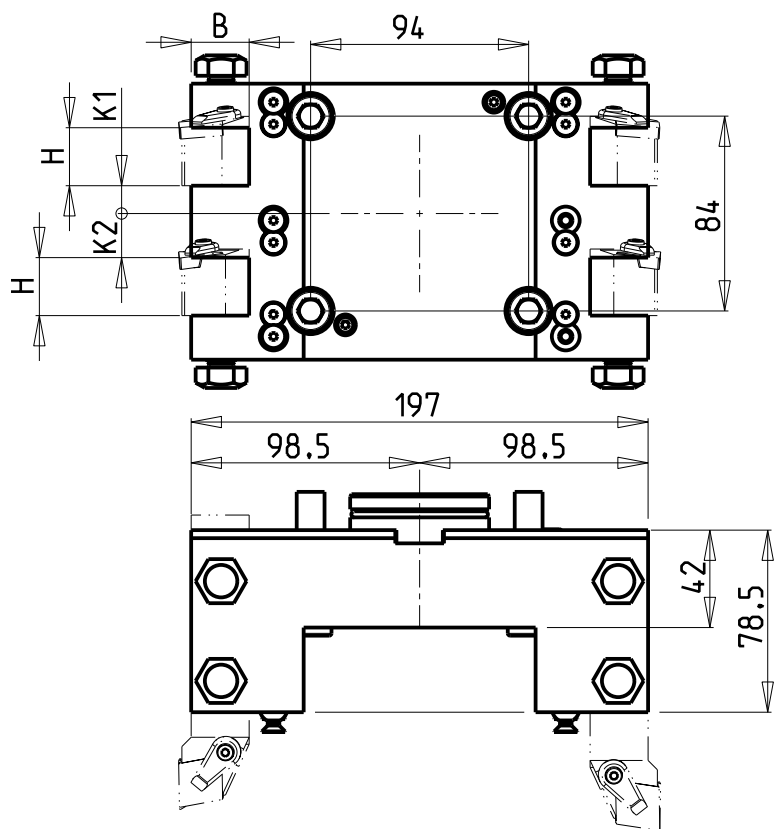

MNL0072010

Cod. MT	N°Utensili N°Tools N°Werkzeuge	Reversibile lato mandrino/contromandrino Reversible sub/main spindle side Umkehrbare Spindel-seite/ Gegenspindel-seite	Lubrificazione int. Coolant through Innenkuehlung	Lubrificazione est. Ext. coolant Aussenkuehlung	Misure Dimensions Masse	H	B	K1	K2
MNL0072500	4	X	-	X	mm	25	25	12	19
MNL0072540	4	X	-	X	Inch	1"	1"	1/2"	3/4"
MNL0072010	4	X	P=70bar	X	mm	20	20	12	19
MNL0071905	4	X	-	X	Inch	3/4"	3/4"	1/2"	3/4"

DMG-MORI

NL1500/2000/2500/3000 12 STAZIONI - NLX1500/2000/2500/3000 12 STAZIONI - NLX4000 - NZL2000/2500 - NZX2500 (BMT60)
NT4200/4250/4300/5400 - CTX2500 (BMT60)

PORTAUTENSILE RADIALE DOPPIO SOVRAPPOSTO QD=25mm / QD=1" / QD=20mm / QD=3/4"

Radial double side twin static tool QD=25mm / QD=1" / QD=20mm / QD=3/4"

Radial Doppel-Werkzeughalter ueberlagert QD=25mm / QD=1" / QD=20mm / QD=3/4"

Subject to change without notice.

M.T. srl

Via Casino Albini 480
Tel. 0541/956034-957884
Fax 0541/956341

47842 S. GIOVANNI IN M. (RN)
e-mail: mtma@mtmarchetti.com
http://www.mtmarchetti.com



PAGINA MNL463-1-00

10/2021

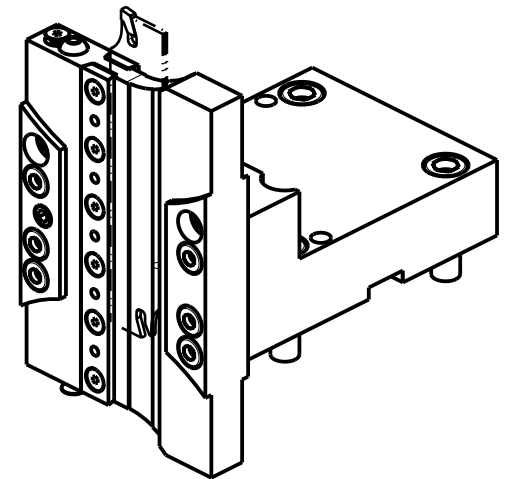
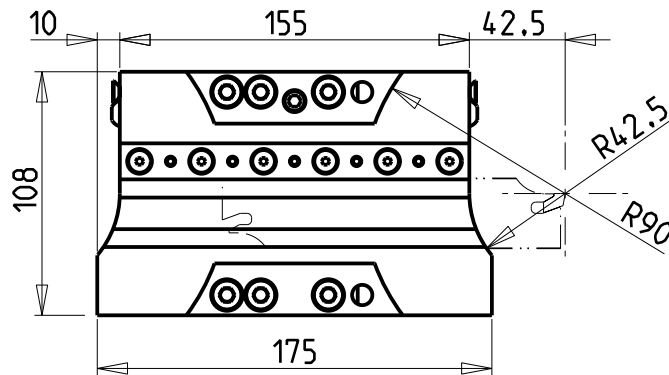
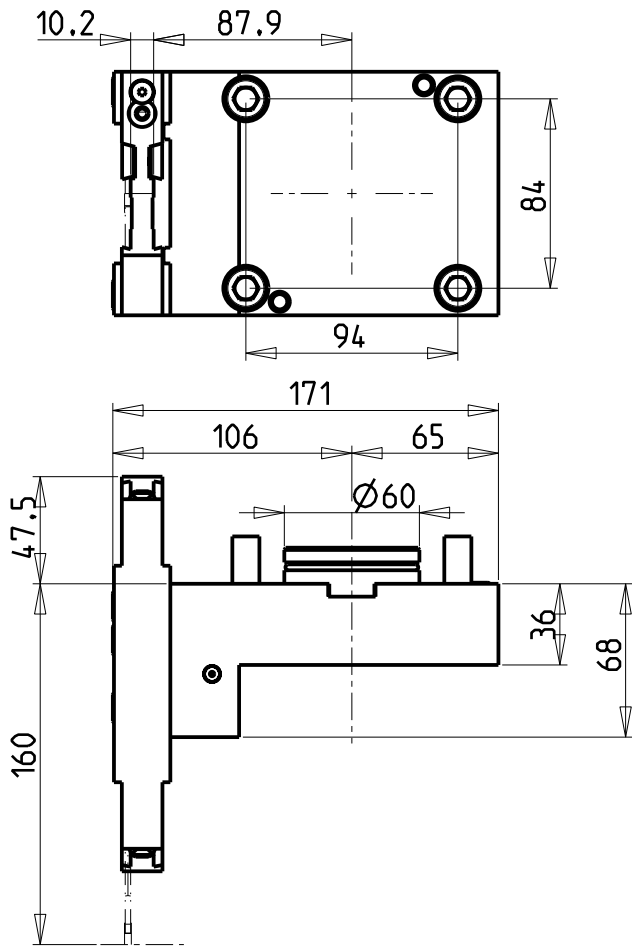

POSSIBILITA' DI LAVORO M3/M4
 OPTION OF M3/M4 WORKING
 ARBEITSMÖGLICHKEIT M3/M4

DOTAZIONI - SUPPLIED WITH - AUSSTATTUNG

- N°1 - LAMA - BLADE - KLINGE ISCAR H=32 Sp. 3/4mm (KENNAMETAL OPTIONAL)
- N°10 - INSERTI - INSERTS - EINLAGEN
- N°1 - CHIAVE A T PER MONTAGGIO INSERTI
 - T-WRENCH FOR INSERT SET UP
 - T-SCHLUESSEL FUER EINSATZSTUECK-MONTAGE

Cod. MT	N°Utensili N°Tools N°Werkzeuge
MNL0140132	1

DMG-MORI

NL1500/2000/2500/3000 12 STAZIONI - NLX1500/2000/2500/3000 12 STAZIONI - NLX4000 - NZL2000/2500 - NZX2500 (BMT60)
 NTX2000/2500/3000 2ND GEN. 10ST. - CTX2500 (BMT60)

PORTAUTENSILE PER LAMA DOPPIO

Radial double blade holder

Radial Doppel-Abstechhalter

Subject to change without notice.

M.T. srl

Via Casino Albini 480
 Tel. 0541/956034-957884
 Fax 0541/956341
 47842 S. GIOVANNI IN M. (RN)
 e-mail: mtma@mtmarchetti.com
 http://www.mtmarchetti.com



PAGINA MNL520-1-00

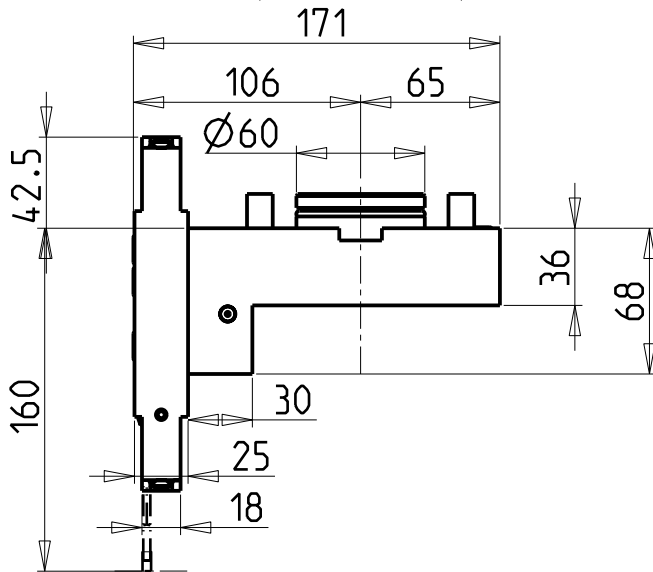
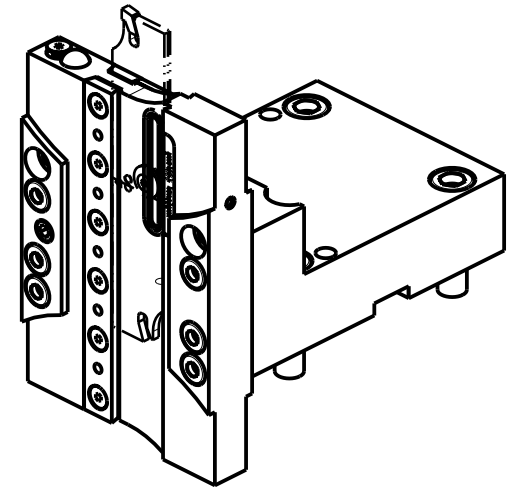
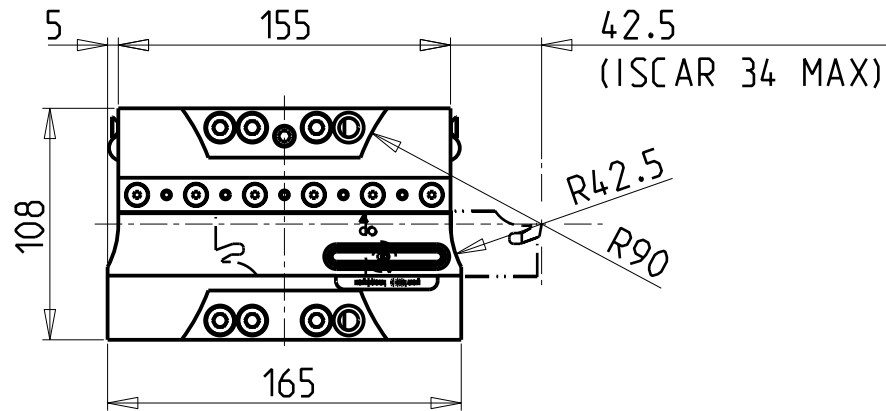
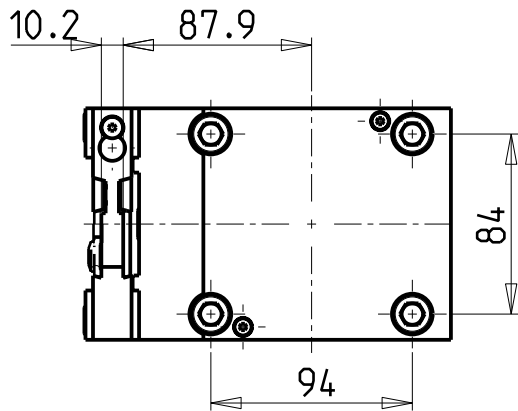

POSSIBILITA' DI LAVORO M3/M4
 OPTION OF M3/M4 WORKING
 ARBEITSMÖGLICHKEIT M3/M4

**KIT LAME NON INCLUSI (OPZIONALI)
 BLADES NOT SUPPLIED WITH (OPTIONAL)
 KLINGEN NICHT INBEGRIFFEN (OPTIONAL)**

- LAMA-BLADE-KLINGE SANDVIK H=32 sp.3 cod. QD_NN2G60C 25A
 +INSERTI-INSERTS-EINLAGEN cod. QD_NG_0300_0002_CM_1145 (10 pz.)
- LAMA-BLADE-KLINGE SANDVIK H=32 sp.4 cod. QD_NN2H60C 25A
 +INSERTI-INSERTS-EINLAGEN cod. QD_NH_0400_0002_CM_1145 (10 pz.)
- LAMA-BLADE-KLINGE ISCAR H=32 sp.3 cod. SGFH_32K_3
 +INSERTI-INSERTS-EINLAGEN cod. 6011365 (10pz.)
- LAMA-BLADE-KLINGE ISCAR H=32 sp.4 cod. SGFH_32K_4
 +INSERTI-INSERTS-EINLAGEN cod. 6011366 (10pz.)
- LAMA-BLADE-KLINGE WALTER H=32 sp.3 cod. G2042.32N-3T45SX-P
 +INSERTI-INSERTS-EINLAGEN cod. SX-3E300N02-CE4 WSM33S (10pz.) + CHIAVE-KEY cod. FS1494
- LAMA-BLADE-KLINGE WALTER H=32 sp.4 cod. G2042.32N-4T50SX-P
 +INSERTI-INSERTS-EINLAGEN cod. SX-4E400N02-CE4 WSM33S (10pz.) + CHIAVE-KEY cod. FS1494

Cod. MT	N°Utensili N°Tools N°Werkzeuge	Lubr.esterna Ext. coolant Aussenkuehlung	Lubr.interna Coolant through Innenkuehlung
MNL0860132	1	X	P=70bar

DMG-MORI

NL1500/2000/2500/3000 12 STAZIONI - NLX1500/2000/2500/3000 12 STAZIONI - NLX4000 - NZL2000/2500 - NZX2500 (BMT60)
 NTX2000/2500/3000 2ND GEN. 10ST. - CTX2500 (BMT60)

PORTAUTENSILE PER LAMA DOPPIO CON LUBRIFICAZIONE INTERNA

Radial double blade holder with internal coolant

Radial Doppel-Abstechhalter mit Innenkuehlung

Subject to change without notice.

M.T. srl

Via Casino Albini 480
 Tel. 0541/956034-957884
 Fax 0541/956341
 47842 S. GIOVANNI IN M. (RN)
 e-mail: mtma@mtmarchetti.com
 http://www.mtmarchetti.com



PAGINA MNL520-1-04

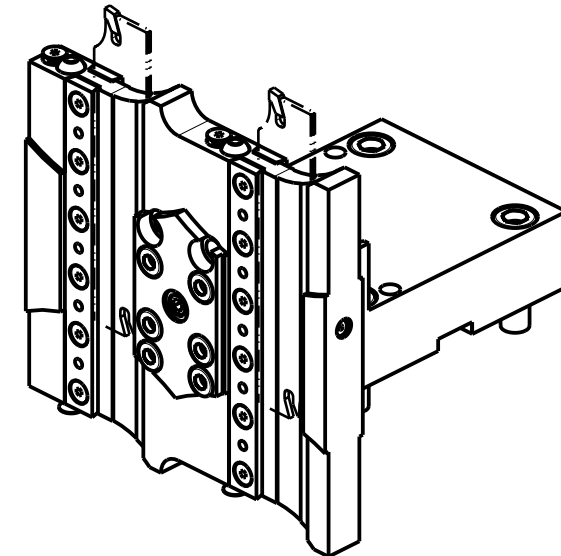
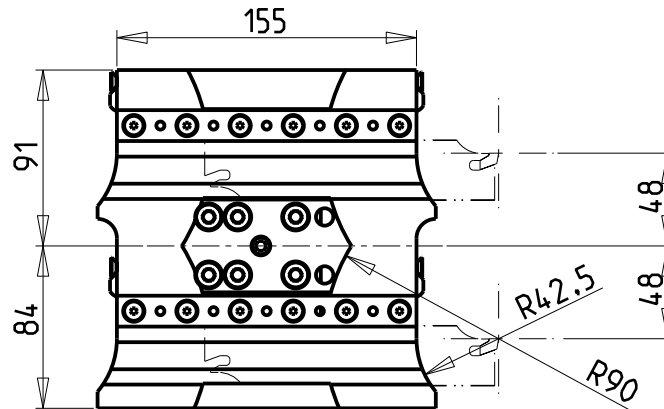
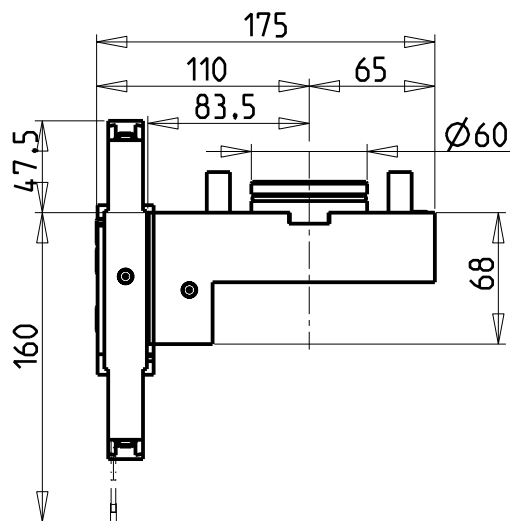
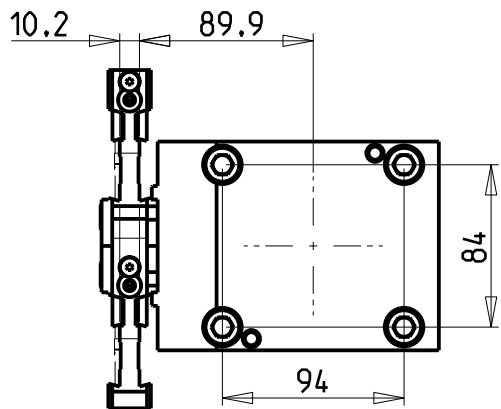

POSSIBILITA' DI LAVORO M3/M4
 OPTION OF M3/M4 WORKING
 ARBEITSMOGLICHKEIT M3/M4

SOLO PER MACCHINE CON ASSE Y
 ONLY FOR Y-AXIS MACHINES
 NUR FUR MASCHINEN MIT ACHSE Y

DOTAZIONI - SUPPLIED WITH - AUSSTATTUNG

N°1 - LAMA - BLADE - KLINGE ISCAR H=32 Sp. 3/4mm
 (KENNAMETAL OPTIONAL)

N°10 - INSERTI - INSERTS - EINLAGEN

N°1 - CHIAVE A T PER MONTAGGIO INSERTI
 - T-WRENCH FOR INSERT SET UP
 - T-SCHLUESSEL FUER EINSATZSTUECK-MONTAGE

Cod. MT

N°Utensili
 N° Tools
 N° Werkzeuge

MNL0160232

2

DMG-MORI

NL1500/2000/2500/3000 12 STAZIONI - NLX1500/2000/2500/3000 12 STAZIONI - NLX4000 - NZL2000/2500 - NZX2500 (BMT60)
 CTX2500 (BMT60)

PORTAUTENSILE PER LAMA DOPPIO SOVRAPPOSTO

Radial double twin-side blade holder

Radial Doppel-Abstechhalter ueberlagert

Subject to change without notice.

M.T. srl

Via Casino Albini 480
 Tel. 0541/956034-957884
 Fax 0541/956341
 47842 S. GIOVANNI IN M. (RN)
 e-mail: mtma@mtmarchetti.com
 http://www.mtmarchetti.com



PAGINA MNL525-1-00

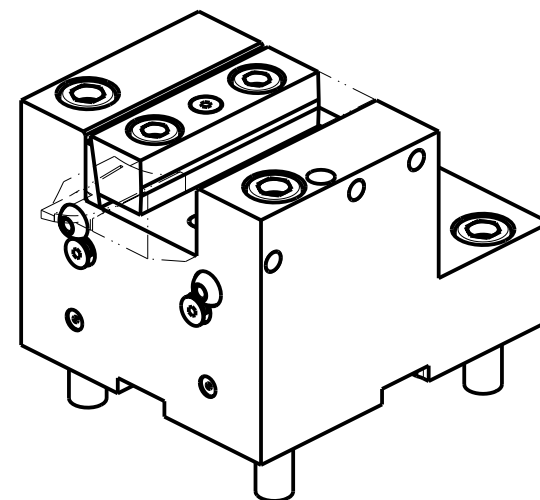
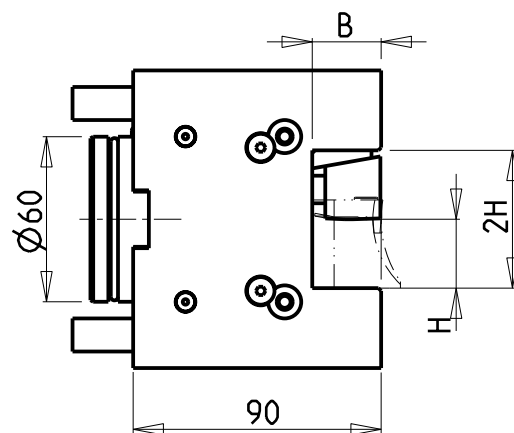
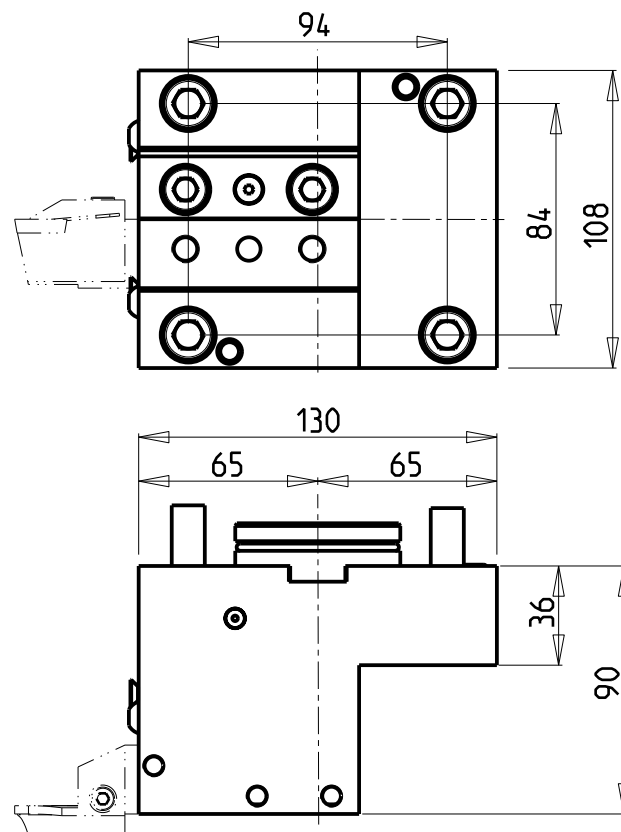

Cod. MT	Cod. MORI-SEIKI	N°Utensili N°Tools N°Werkzeuge	Reversibile lato mandrino/contromandrino Reversible sub/main spindle side Umkehrbare Spindel-seite/ Gegenspindel-seite	Misure Dimensions Masse	B	H
MNL0132500	T03005	1/2	X	mm	25	25
MNL0132540	T03013	1/2	X	Inch	1"	1"
MNL0132000	T03006	1/2	X	mm	20	20
MNL0131905	T03014	1/2	X	Inch	3/4"	3/4"

DMG-MORI

NL1500/2000/2500/3000 12 STAZIONI - NLX1500/2000/2500/3000 12 STAZIONI - NLX4000 - NZL2000/2500 - NZX2500 (BMT60)
 NT4200/4250/4300/5400 - NTX2000/2500/3000 2ND GEN. 10ST. - CTX2500 (BMT60)

PORTAUTENSILE ASSIALE SINGOLO QD=25mm / QD=1" / QD=20mm / QD=3/4"

Single axial static tool QD=25mm / QD=1" / QD=20mm / QD=3/4"

Axial Single-Werkzeughalter QD=25mm / QD=1" / QD=20mm / QD=3/4"

Subject to change without notice.

M.T. srl

Via Casino Albini 480
 Tel. 0541/956034-957884
 Fax 0541/956341
 47842 S. GIOVANNI IN M. (RN)
 e-mail: mtma@mtmarchetti.com
 http://www.mtmarchetti.com



PAGINA MNL552-1-00

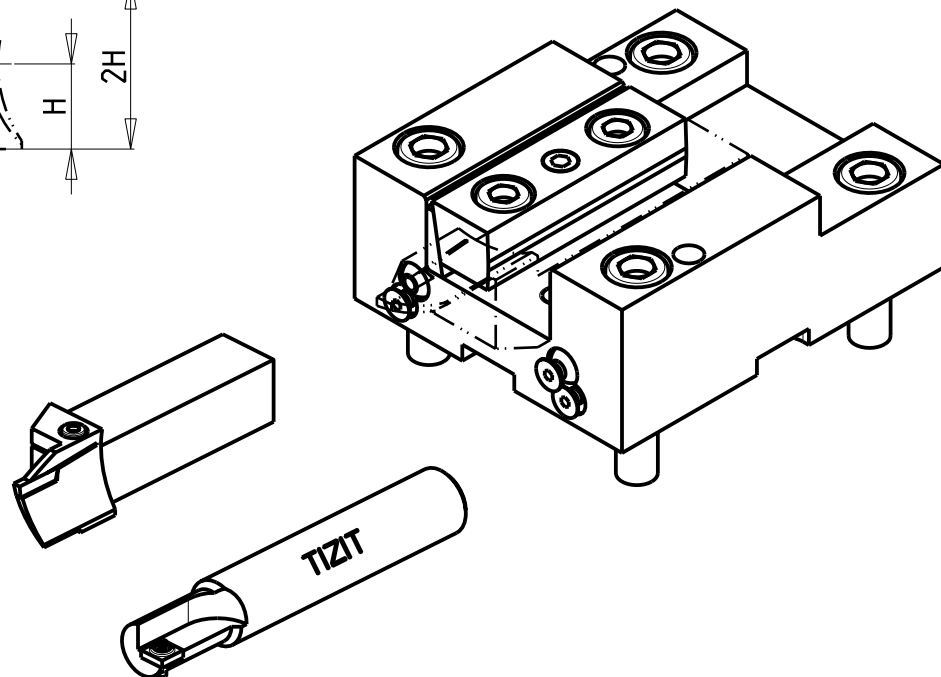
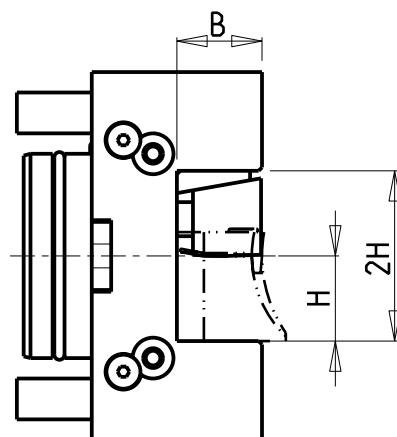
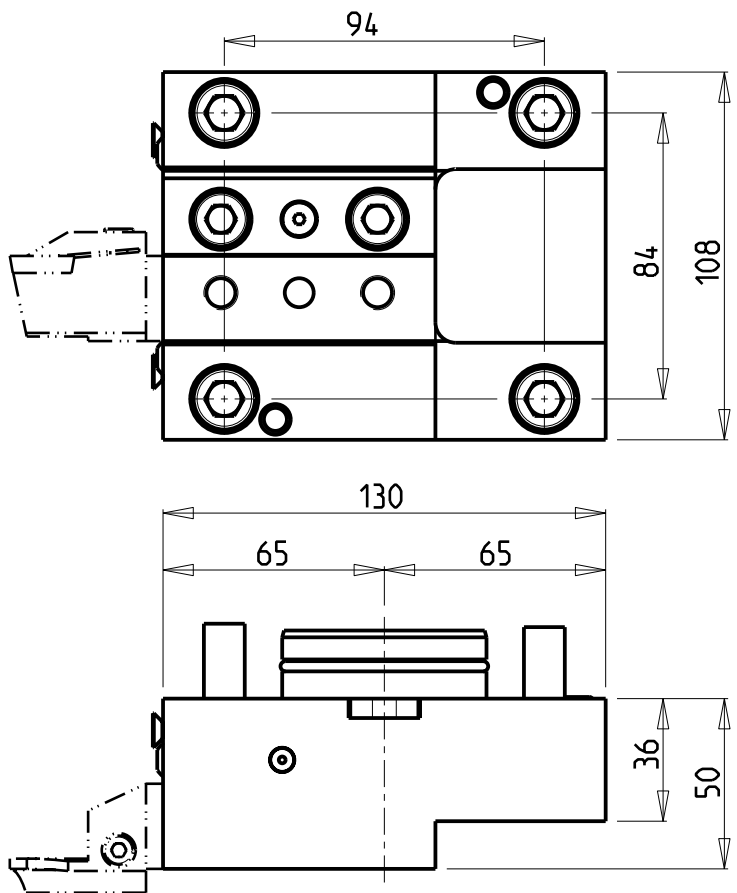

Cod. MT	Cod. MORI-SEIKI	N°Utensili N° Tools N° Werkzeuge	Reversibile lato mandrino/contromandrino Reversible sub/main spindle side Umkehrbare Spindel-seite/ Gegenspindel-seite	Misure Dimensions Masse	B	H
MNL0302500	T03005	1	X	mm	25	25
MNL0302000	T03006	1	X	mm	20	20

DMG-MORI

NL1500/2000/2500/3000 12 STAZIONI - NLX1500/2000/2500/3000 12 STAZIONI - NLX4000 - NZL2000/2500 - NZX2500 (BMT60)
NT4200/4250/4300/5400 - CTX2500 (BMT60)

PORTAUTENSILE ASSIALE RIBASSATO SINGOLO QD=25mm / QD=20mm

Axial single lower height static tool QD=25mm / QD=20mm

Axial Single-Werkzeughalter abgeflacht QD=25mm / QD=20mm

Subject to change without notice.

M.T. srl

Via Casino Albini 480
Tel. 0541/956034-957884
Fax 0541/956341
47842 S. GIOVANNI IN M. (RN)
e-mail: mtma@tmarchetti.com
<http://www.tmmarchetti.com>



PAGINA MNL562-1-00

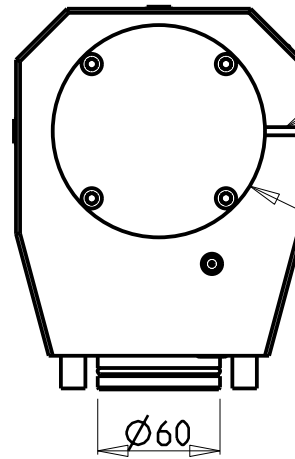
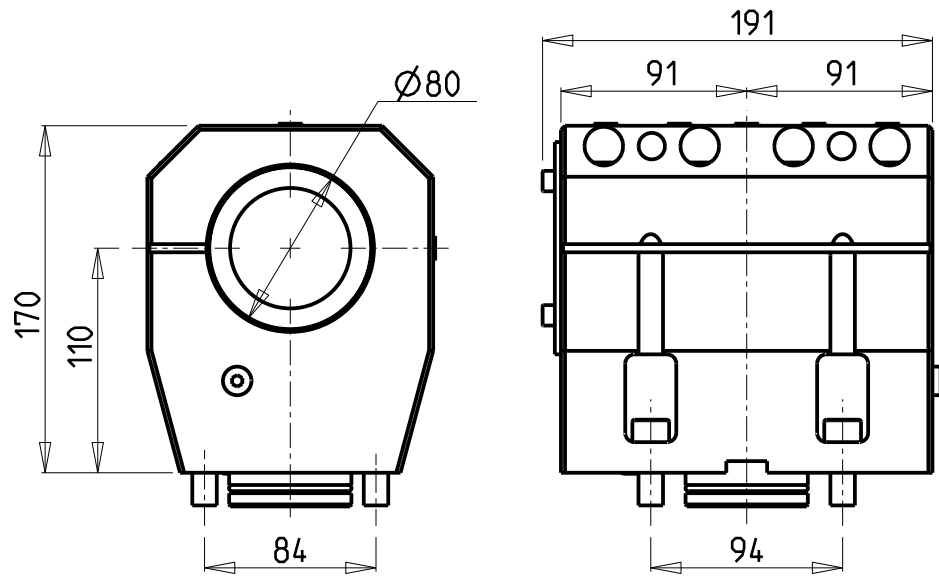

SOLO GUARNIZIONE (OPZIONALE)
 ONLY SEAL (OPTIONAL)
 NUR DICHTUNG (OPTIONAL)
 cod. MNL0620002

KIT ADDUZIONE INTERNA (OPZIONALE)
 KIT FOR INTERNAL COOLANT (OPTIONAL)
 KIT FUER INTERNE KUEHLMITTELZUFUHR (OPTIONAL)
 Ø80 cod. KIT1005013

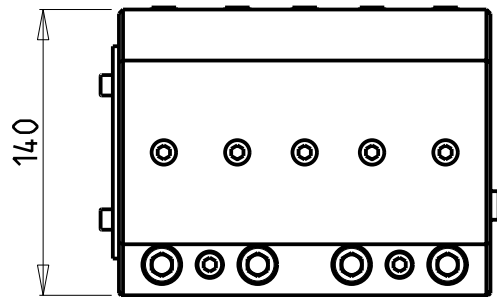

ATTENZIONE - ATTENTION - ACHTUNG

- VERIFICARE LE MISURE DI INGOMBRO PER POSSIBILE INTERFERENZA SU ALCUNI MODELLI DI MACCHINE
- Please check the overall sizes for possible interferences on some machine models
- Bitte überprüfen sie das ausmass um mögliche interferenzen auf einigen maschinen modellen zu vermeiden

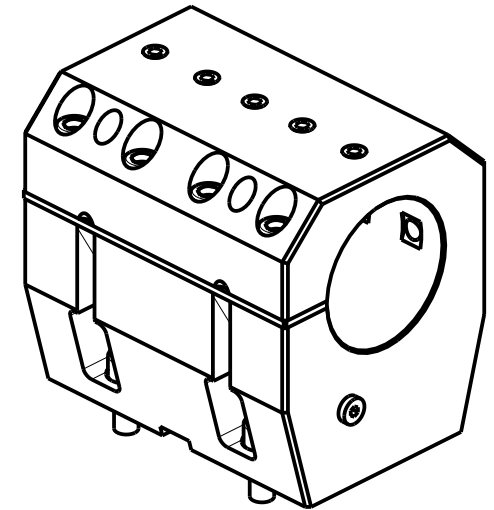

Cod. MT	N°Utensili N°Tools N°Werkzeuge	Lubrificazione int. opzionale Coolant through optional Innenkühlung Optional	Lubrificazione est. Ext. coolant Aussenkühlung
MNL0628000	1	X	X

DMG-MORI

NL1500/2000/2500/3000 12 STAZIONI - NLX1500/2000/2500/3000 12 STAZIONI - NLX4000 - NZL2000/2500 - NZX2500 (BMT60)
 NT4200/4250/4300/5400 - CTX2500 (BMT60)

PORTAUTENSILE ASSIALE PER BARENO Ø80mm H=110mm

Axial single boring bar holder Ø80mm H=110mm

Axial Bohrhälter Ø80mm H=110mm

Subject to change without notice.

M.T. srl

Via Casino Albini 480
 Tel. 0541/956034-957884
 Fax 0541/956341
 47842 S. GIOVANNI IN M. (RN)
 e-mail: mtma@mtmarchetti.com
 http://www.mtmarchetti.com



PAGINA MNL580-1-20

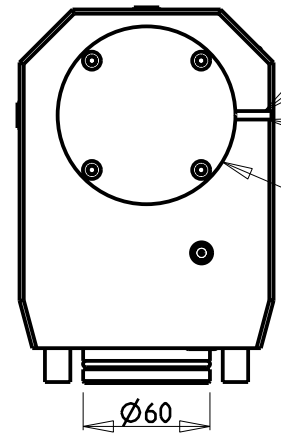
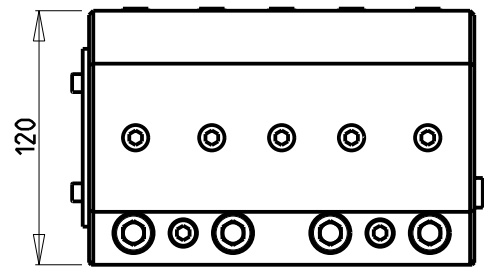
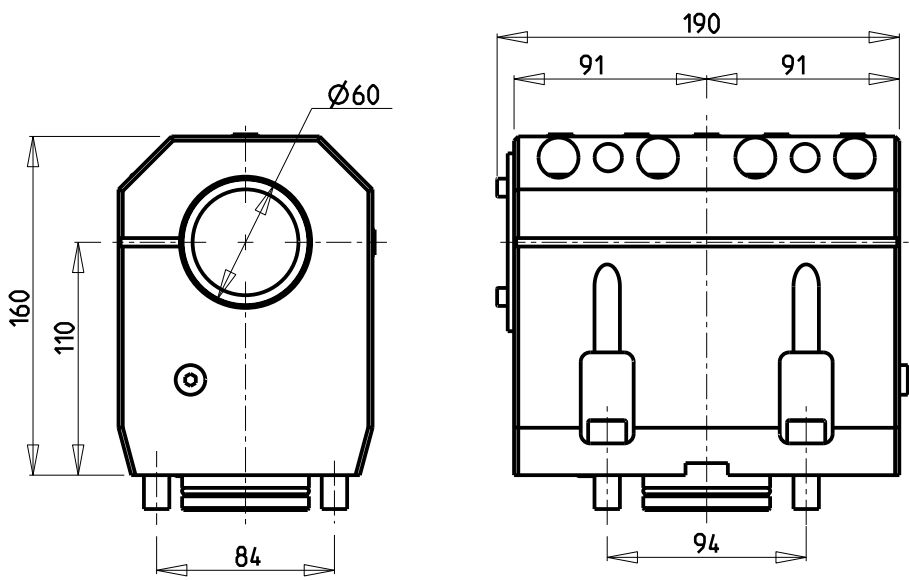

SOLO GUARNIZIONE (OPZIONALE)
 ONLY SEAL (OPTIONAL)
 NUR DICHTUNG (OPTIONAL)
 cod. MNL0620002

KIT ADDUZIONE INTERNA (OPZIONALE)
 KIT FOR INTERNAL COOLANT (OPTIONAL)
 KIT FUER INTERNE KUEHLMITTELZUFUHR (OPTIONAL)
 Ø60 cod. KIT1005025

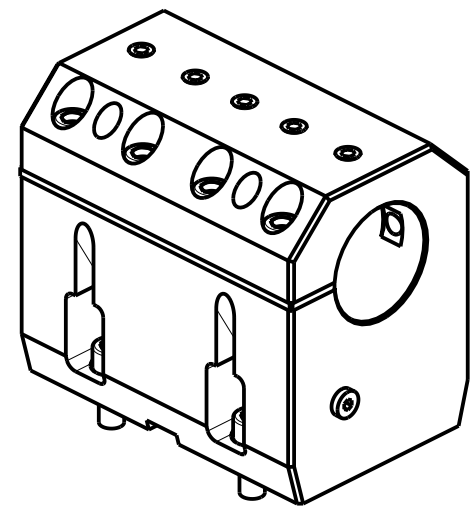

ATTENZIONE - ATTENTION - ACHTUNG

- VERIFICARE LE MISURE DI INGOMBRO PER POSSIBILE INTERFERENZA SU ALCUNI MODELLI DI MACCHINE
- Please check the overall sizes for possible interferences on some machine models
- Bitte überprüfen sie das ausmass um mögliche interferenzen auf einigen maschinen modellen zu vermeiden

Cod. MT	N°Utensili N°Tools N°Werkzeuge	Lubrificazione int. opzionale Coolant through optional Innenkühlung Optional	Lubrificazione est. Ext. coolant Aussenkühlung
MNL0616000	1	X	X

DMG-MORI
 NL1500/2000/2500/3000 12 STAZIONI - NLX1500/2000/2500/3000 12 STAZIONI - NLX4000 - NZL2000/2500 - NZX2500 (BMT60)
 NT4200/4250/4300/5400 - NTX2000/2500/3000 2ND GEN. 10ST. - CTX2500 (BMT60)

PORTAUTENSILE ASSIALE PER BARENO Ø60mm H=110mm
 Axial single boring bar holder Ø60mm H=110mm
 Axial Bohrhälter Ø60mm H=110mm

Subject to change without notice.

M.T. srl
 Via Casino Albini 480
 Tel. 0541/956034-957884
 Fax 0541/956341
 47842 S. GIOVANNI IN M. (RN)
 e-mail: mtma@mtmarchetti.com
 http://www.mtmarchetti.com



PAGINA MNL590-1-20

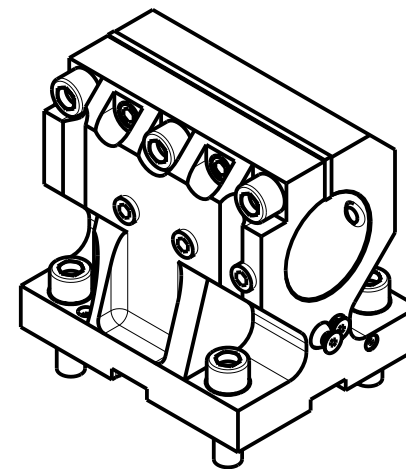
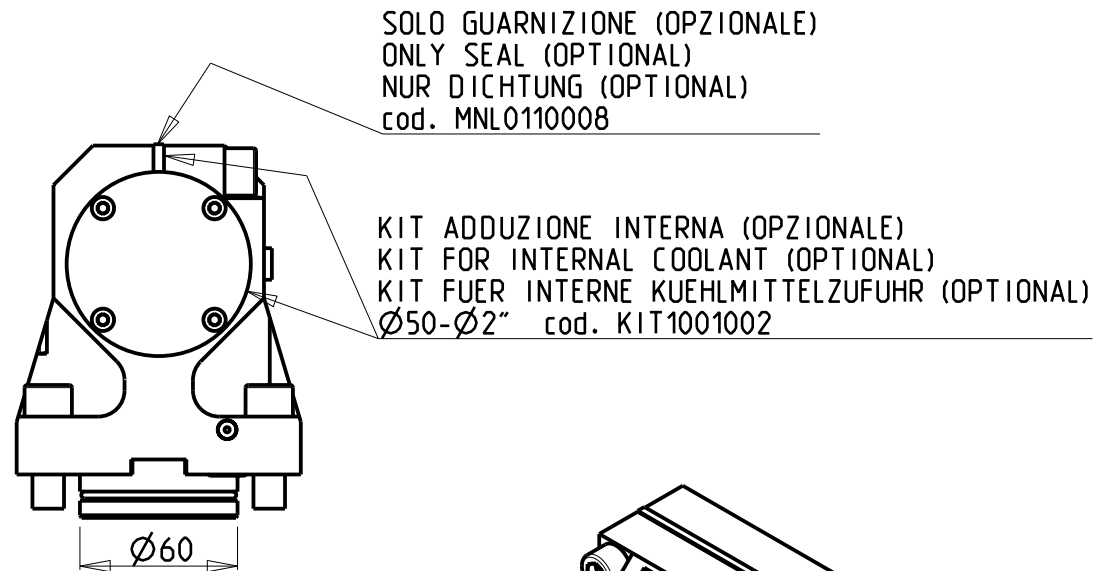
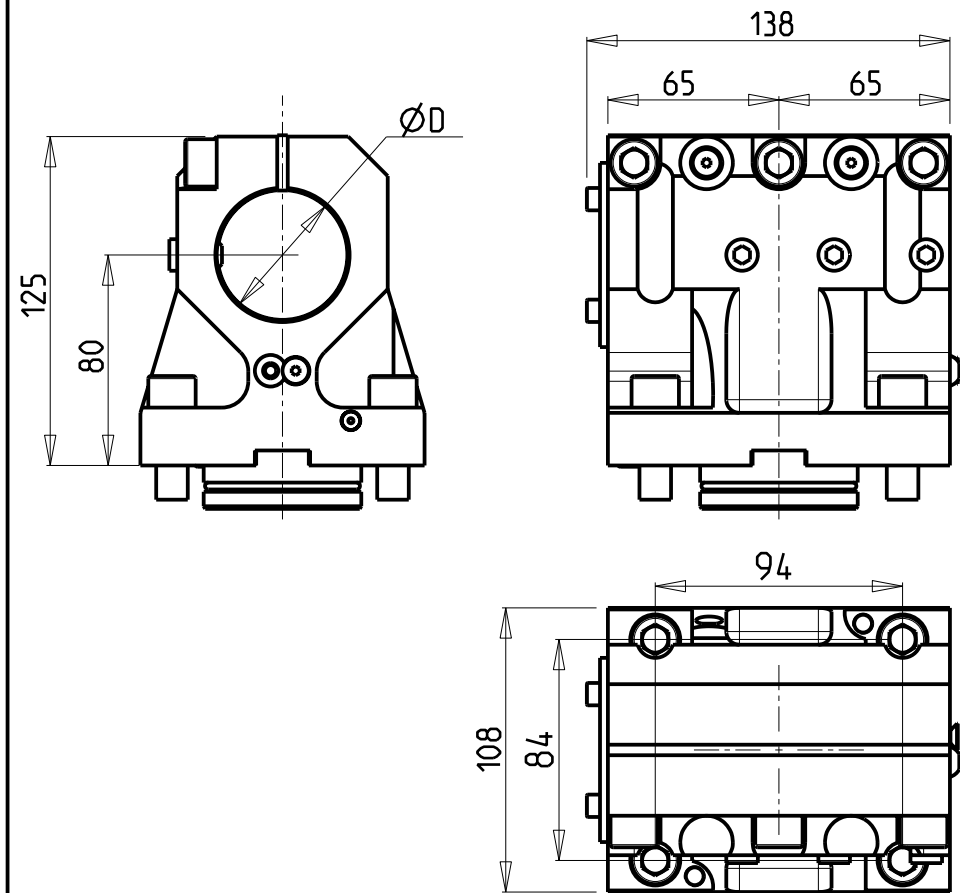

Cod. MT	Cod. MORI-SEIKI	N°Utensili N°Tools N°Werkzeuge	Reversibile lato mandrino/contromandrino Reversible sub/main spindle side Umkehrbare Spindel-seite/ Gegenspindel-seite	Lubrificazione int. opzionale Coolant through optional Innenkuehlung Optional	Lubrificazione est. Ext. coolant Aussenkuehlung	Misure Dimensions Masse	D
MNL0115000	T10098	1	X	X	X	mm	50
MNL0115080	T10102	1	X	X	X	Inch	2"

PER BOCCOLE DI RIDUZIONE VEDI PAG. TBL150-1-00
FOR REDUCING BUSHINGS SEE PAGE TBL150-1-00
FÜR REDUZIERBUCHSE SIEHE SEITE TBL150-1-00

DMG-MORI

NL1500/2000/2500/3000 12 STAZIONI - NLX1500/2000/2500/3000 12 STAZIONI - NLX4000 - NZL2000/2500 - NZX2500 (BMT60)
NTX2000/2500/3000 2ND GEN. 10ST. - CTX2500 (BMT60)

PORTAUTENSILE ASSIALE PER BARENO Ø50mm / Ø2" H=80mm

Axial single boring bar holder Ø50mm / Ø2" H=80mm

Axial Bohrhälter Ø50mm / Ø2" H=80mm

Subject to change without notice.

M.T. srl

Via Casino Albini 480
Tel. 0541/956034-957884
Fax 0541/956341
47842 S. GIOVANNI IN M. (RN)
e-mail: mtma@mtmarchetti.com
http://www.mtmarchetti.com



PAGINA MNL610-1-20

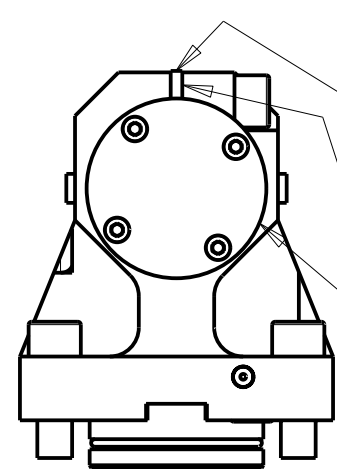
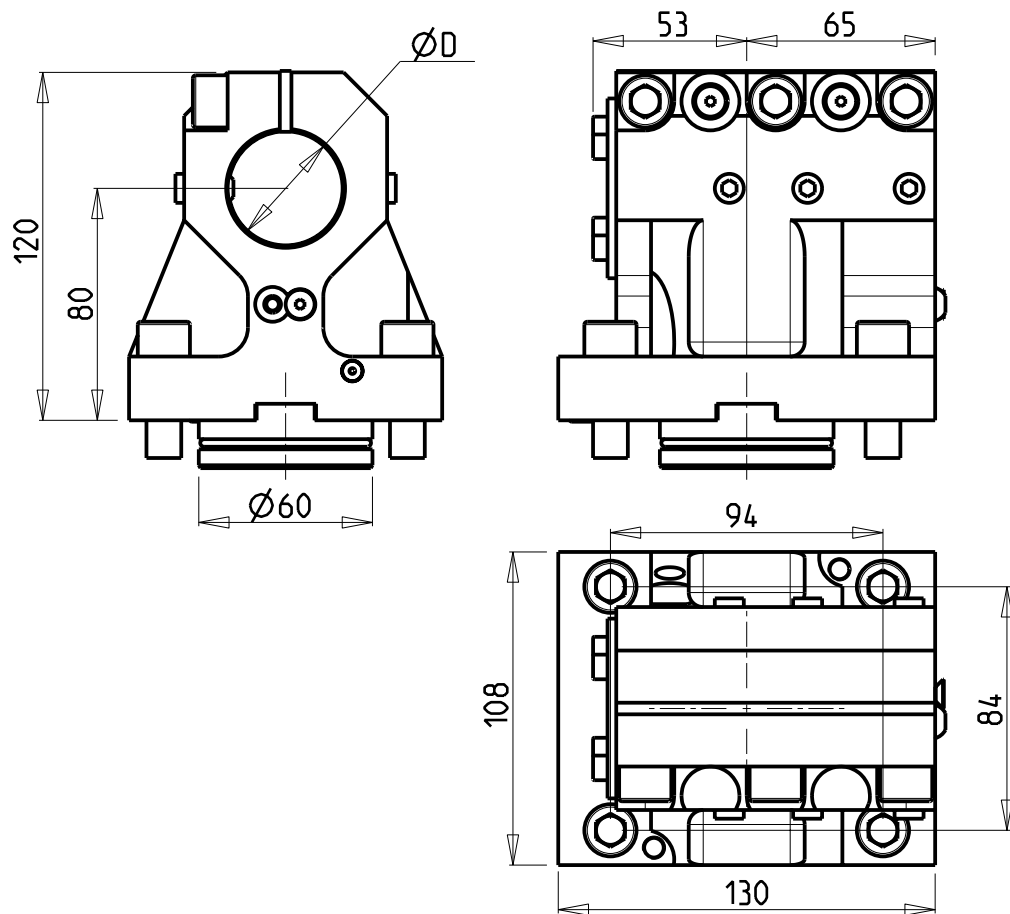

SOLO GUARNIZIONE (OPZIONALE)
 ONLY SEAL (OPTIONAL)
 NUR DICHTUNG (OPTIONAL)
 cod. 0520013

KIT ADDUZIONE INTERNA (OPZIONALE)
 KIT FOR INTERNAL COOLANT (OPTIONAL)
 KIT FUER INTERNE KUEHLMITTELZUFUHR (OPTIONAL)
 Ø40 cod. KIT1003003
 Ø1 1/2" cod. KIT1003004

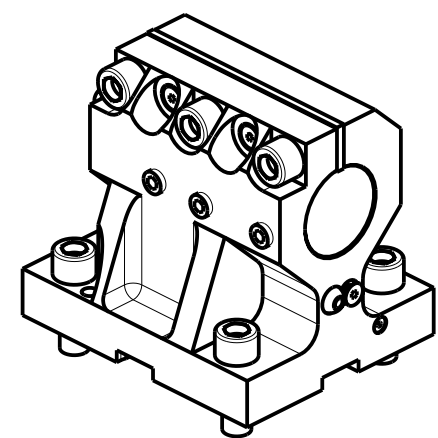

Cod. MT	Cod. MORI-SEIKI	N°Utensili N°Tools N°Werkzeuge	Reversibile lato mandrino/contromandrino Reversible sub/main spindle side Umkehrbare Spindel-seite/ Gegenspindel-seite	Lubrificazione int. opzionale Coolant through optional Innenkühlung Optional	Lubrificazione est. Ext. coolant Aussenkühlung	Misure Dimensions Masse	D
MNL0114000	T10097/T13128	1	X	X	X	mm	40
MNL0113810	T10101/T13130	1	X	X	X	Inch	1 1/2"

PER BOCCOLE DI RIDUZIONE VEDI PAG. TBL150-1-00
 FOR REDUCING BUSHINGS SEE PAGE TBL150-1-00
 FÜR REDUZIERBUCHSE SIEHE SEITE TBL150-1-00

DMG-MORI
 NL1500/2000/2500/3000 12 STAZIONI - NLX1500/2000/2500/3000 12 STAZIONI - NLX4000 - NZL2000/2500 - NZX2500 (BMT60)
 NTX2000/2500/3000 2ND GEN. 10ST. - CTX2500 (BMT60)

PORTAUTENSILE ASSIALE PER BARENO Ø40mm / Ø1 1/2" H=80mm
 Axial single boring bar holder Ø40mm / Ø1 1/2" H=80mm
 Axial Bohrhälter Ø40mm / Ø1 1/2" H=80mm

Subject to change without notice.

M.T. srl
 Via Casino Albini 480
 Tel. 0541/956034-957884
 Fax 0541/956341
 47842 S. GIOVANNI IN M. (RN)
 e-mail: mtma@mtmarchetti.com
 http://www.mtmarchetti.com



PAGINA MNL630-1-20

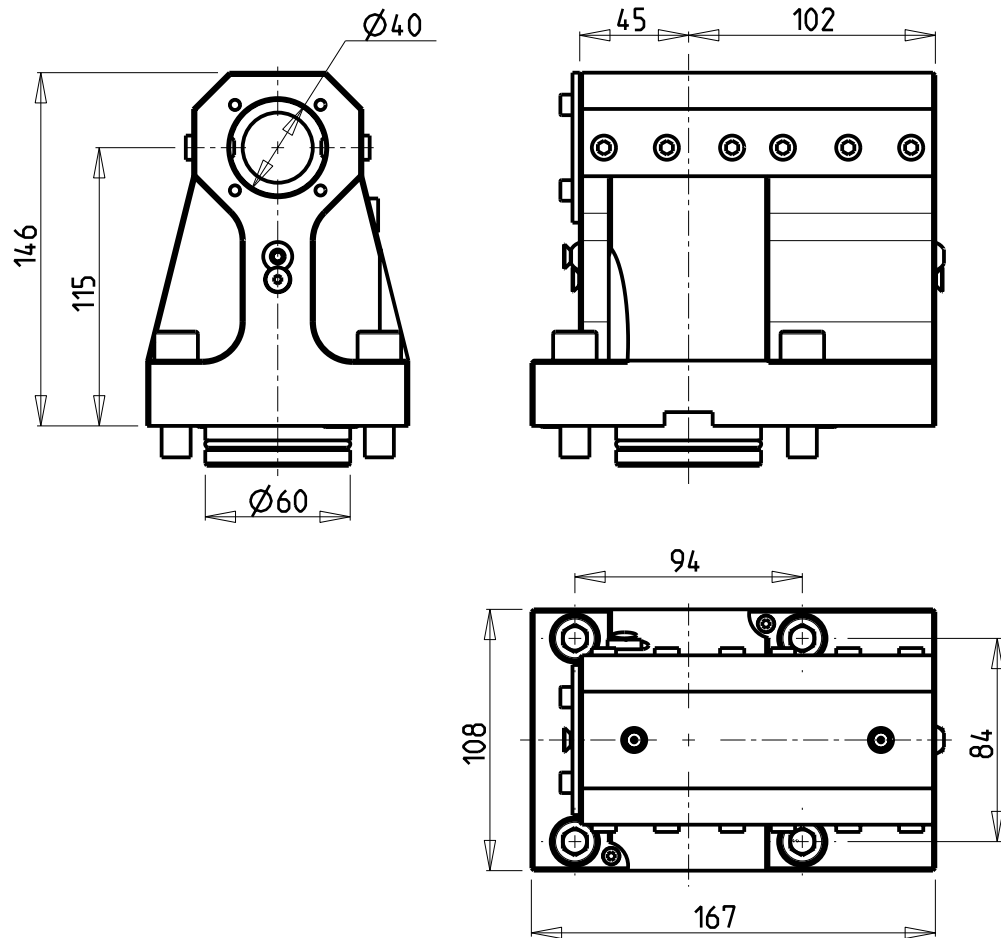

KIT ADDUZIONE INTERNA (OPZIONALE)
 KIT FOR INTERNAL COOLANT (OPTIONAL)
 KIT FUER INTERNE KUEHLMITTELZUFUHR (OPTIONAL)
 Ø40 cod. KIT1000003

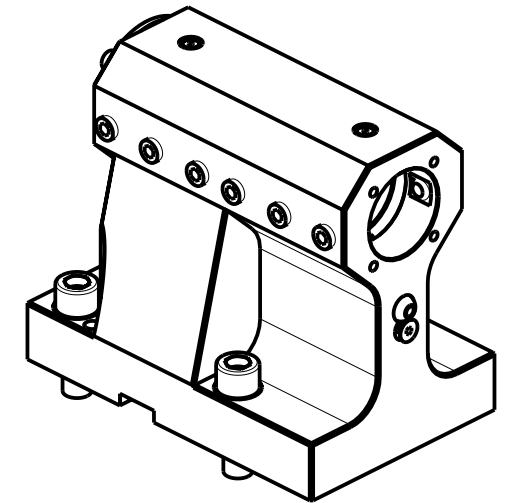

PER BOCCOLE DI RIDUZIONE VEDI PAG. TBL150-1-00
 FOR REDUCING BUSHINGS SEE PAGE TBL150-1-00
 FÜR REDUZIERBUCHSE SIEHE SEITE TBL150-1-00

Cod. MT	N°Utensili N°Tools N°Werkzeuge	Reversibile lato mandrino/contromandrino Reversible sub/main spindle side Umkehrbare Spindel-seite/ Gegenspindel-seite	Lubrificazione int. opzionale Coolant through optional Innenkühlung Optional	Lubrificazione est. Ext. coolant Aussenkühlung
MNL0604000	1	X	X	X

DMG-MORI

NL1500/2000/2500/3000 12 STAZIONI - NLX1500/2000/2500/3000 12 STAZIONI - NLX4000 - NZL2000/2500 - NZX2500 (BMT60)
 NT4200/4250/4300/5400 - NTX2000/2500/3000 2ND GEN. 10ST. - CTX2500 (BMT60)

PORTAUTENSILE ASSIALE PROLUNGATO PER BARENO Ø40mm H=115mm

Axial single extended boring bar holder Ø40mm H=115mm

Axial Bohrhälter verlaengerf Ø40mm H=115mm

Subject to change without notice.

M.T. srl

Via Casino Albini 480
 Tel. 0541/956034-957884
 Fax 0541/956341
 47842 S. GIOVANNI IN M. (RN)
 e-mail: mtma@mtmarchetti.com
 http://www.mtmarchetti.com



PAGINA MNL760-1-10

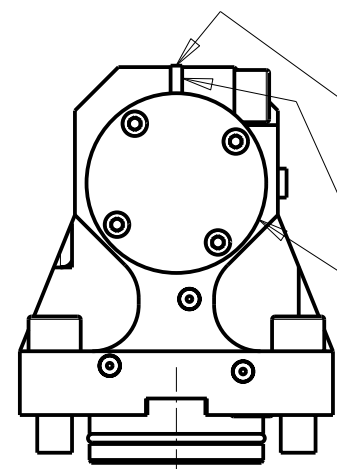
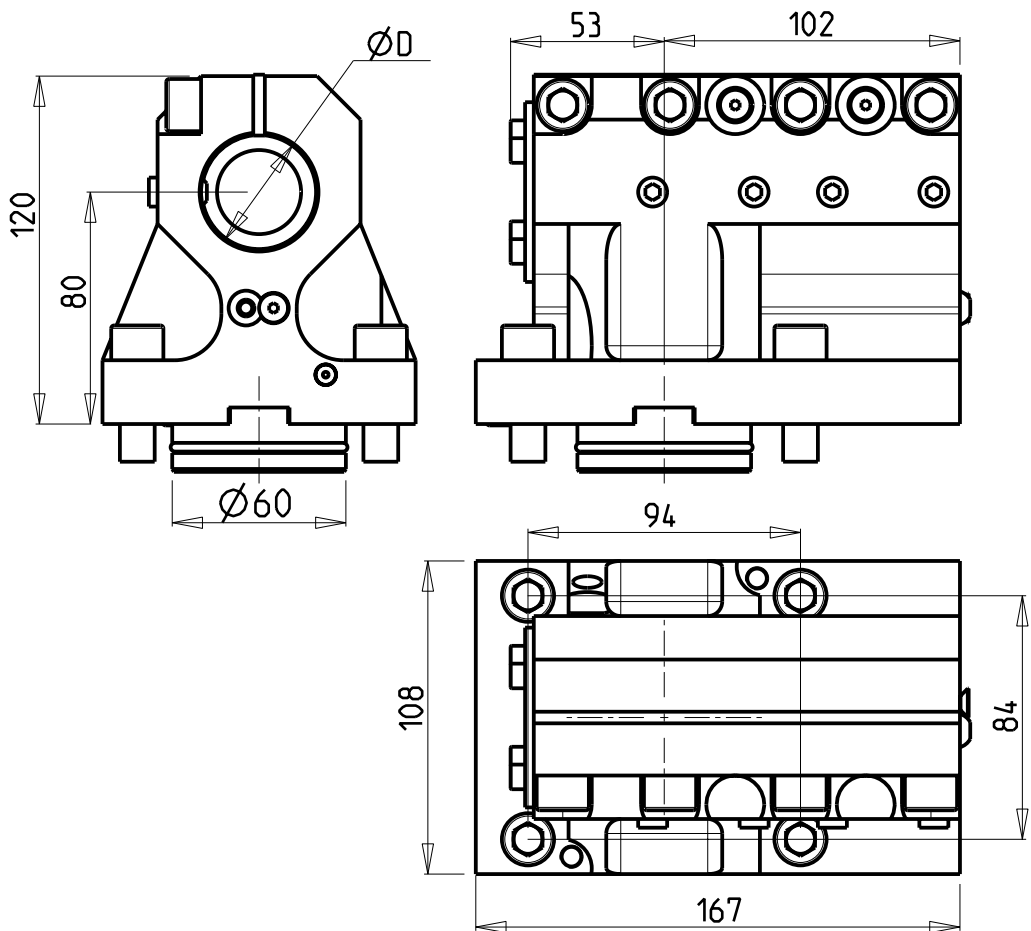

SOLO GUARNIZIONE (OPZIONALE)
 ONLY SEAL (OPTIONAL)
 NUR DICHTUNG (OPTIONAL)
 cod. MNL0310005

KIT ADDUZIONE INTERNA (OPZIONALE)
 KIT FOR INTERNAL COOLANT (OPTIONAL)
 KIT FUER INTERNE KUEHLMITTELZUFUHR (OPTIONAL)
 Ø40 cod. KIT1002003
 Ø1 1/2" cod. KIT1002004

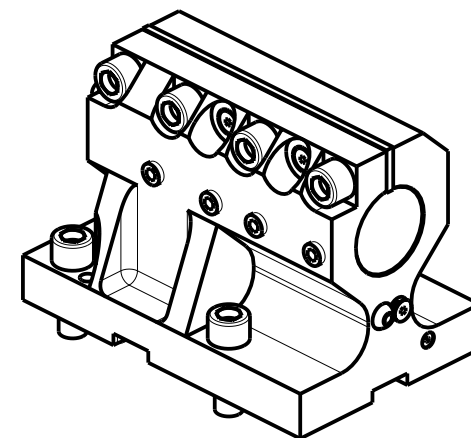

Cod. MT	N°Utensili N° Tools N° Werkzeuge	Reversibile lato mandrino/contromandrino Reversible sub/main spindle side Umkehrbare Spindel-seite/ Gegenspindel-seite	Lubrificazione int. opzionale Coolant through optional Innenkuhlung Optional	Lubrificazione est. Ext. coolant Aussenkuhlung ..	Misure Dimensions Masse	D
MNL0314000	1	X	X	X	mm	40
MNL0313810	1	X	X	X	inch	1 1/2"

PER BOCCOLE DI RIDUZIONE VEDI PAG. TBL150-1-00
 FOR REDUCING BUSHINGS SEE PAGE TBL150-1-00
 FUR REDUZIERBUCHSE SIEHE SEITE TBL150-1-00

DMG-MORI

NL1500/2000/2500/3000 12 STAZIONI - NLX1500/2000/2500/3000 12 STAZIONI - NLX4000 - NZL2000/2500 - NZX2500 (BMT60)
 NTX2000/2500/3000 2ND GEN. 10ST. - CTX2500 (BMT60)

PORTAUTENSILE ASSIALE PROLUNGATO PER BARENO Ø40mm / Ø1 1/2" H=80mm

Axial single extended boring bar holder Ø40mm / Ø1 1/2" H=80mm

Axial Bohrhälter verlaengerf Ø40mm / Ø1 1/2" H=80mm

Subject to change without notice.

M.T. srl

Via Casino Albini 480
 Tel. 0541/956034-957884
 Fax 0541/956341

47842 S. GIOVANNI IN M. (RN)
 e-mail: mtma@mtmarchetti.com
 http://www.mtmarchetti.com



PAGINA MNL760-1-20

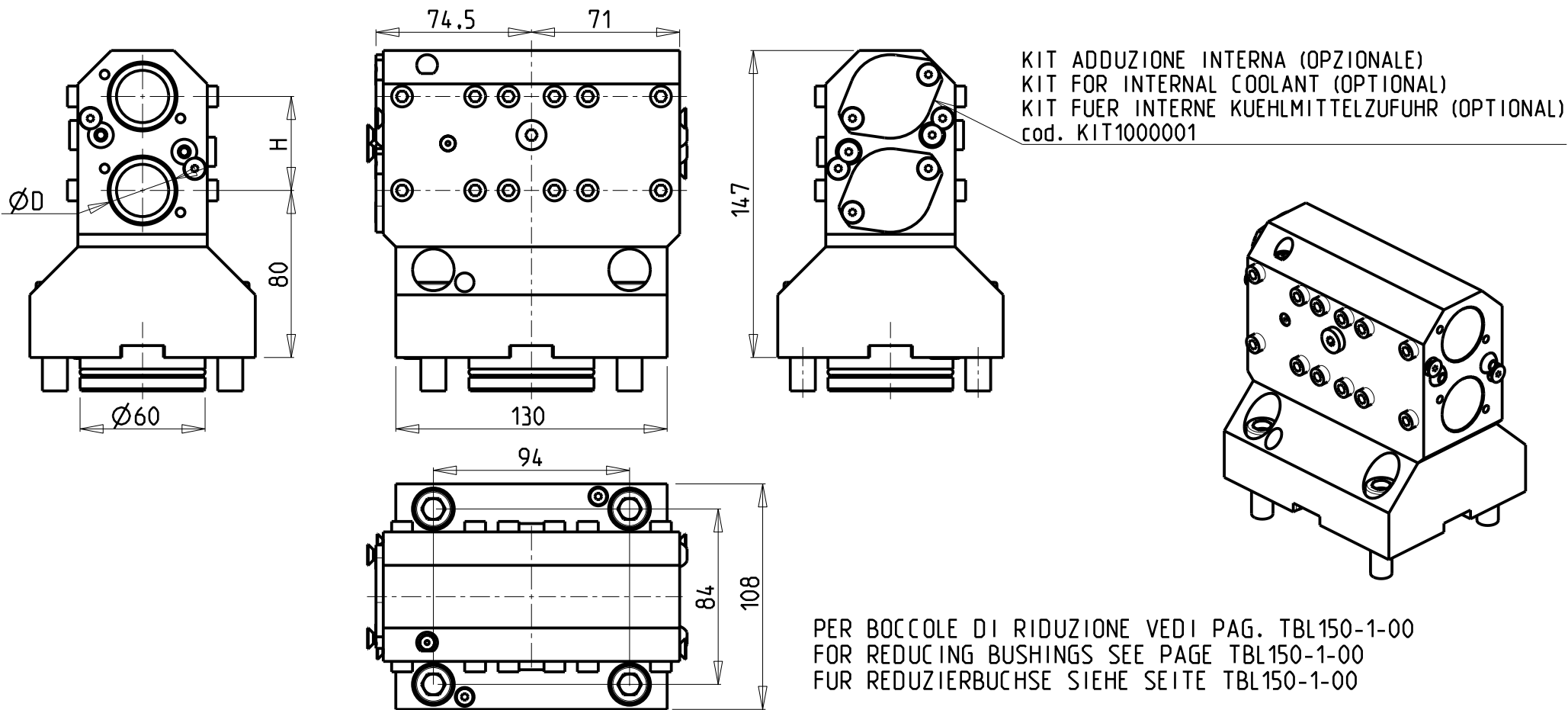

Cod. MT	Cod. MORI-SEIKI	N°Utensili N°Tools N°Werkzeuge	Lubrificazione int. opzionale Coolant through optional Innenkuehlung Optional	Lubrificazione est. Ext. coolant Aussenkuehlung	Misure Dimensions Masse	D	H
MNL0103200	T10096	2+2	X	X	mm	32	45
MNL0103175	T10100	2+2	X	X	Inch	1 1/4"	1 3/4"

DMG-MORI

NL1500/2000/2500/3000 12 STAZIONI - NLX1500/2000/2500/3000 12 STAZIONI - NLX4000 - NZL2000/2500 - NZX2500 (BMT60)
 NTX2000/2500/3000 2ND GEN. 10ST. - CTX2500 (BMT60)

PORTAUTENSILE ASSIALE PER BARENO 2+2 POSIZIONI Ø32mm / Ø1 1/4"

Axial 2+2 position boring bar holder Ø32mm / Ø1 1/4"

Axial Bohrhalter 2+2 Positionen Ø32mm / Ø1 1/4"

Subject to change without notice.

M.T. srl

Via Casino Albini 480
 Tel. 0541/956034-957884
 Fax 0541/956341

47842 S. GIOVANNI IN M. (RN)
 e-mail: mtma@mtmarchetti.com
 http://www.mtmarchetti.com



PAGINA MNL872-1-00

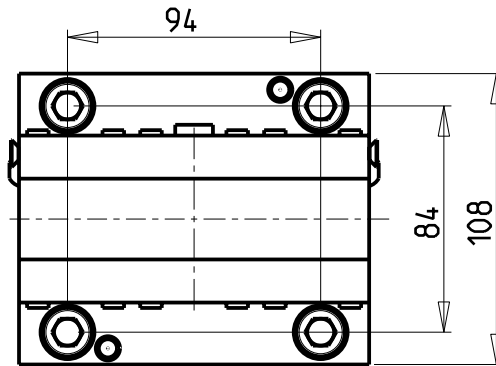
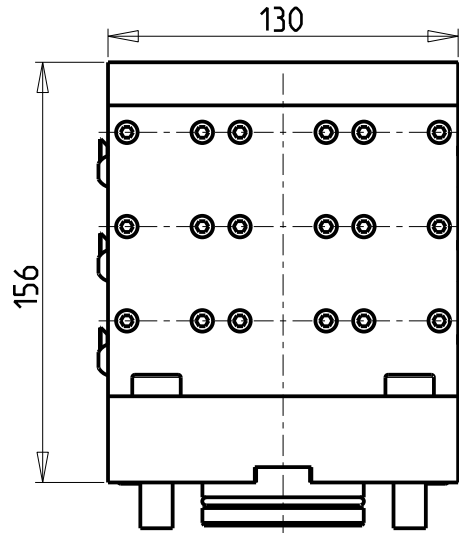
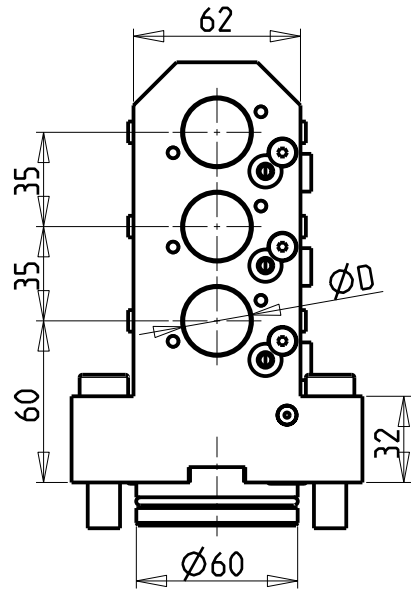

KIT ADDUZIONE INTERNA (OPZIONALE)
 KIT FOR INTERNAL COOLANT (OPTIONAL)
 KIT FUER INTERNE KUEHLMITTELZUFUHR (OPTIONAL)
 cod. KIT1000006

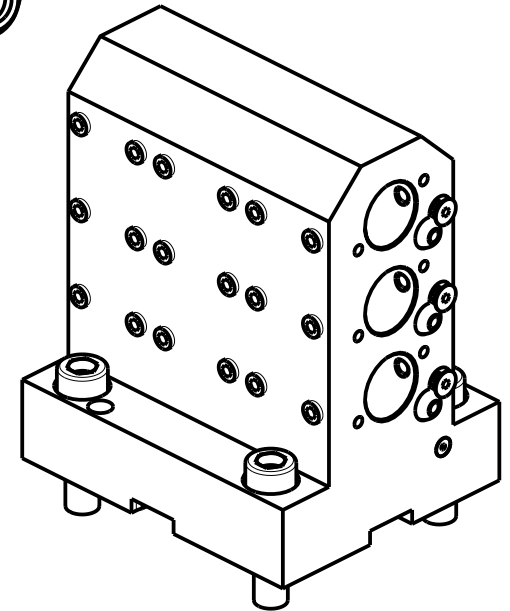

PER BOCCOLE DI RIDUZIONE VEDI PAG. TBL150-1-00
 FOR REDUCING BUSHINGS SEE PAGE TBL150-1-00
 FÜR REDUZIERBUCHSE SIEHE SEITE TBL150-1-00

Cod. MT	N°Utensili N°Tools N°Werkzeuge	Reversibile lato mandrino/contromandrino Reversible sub/main spindle side Umkehrbare Spindel-seite/ Gegenspindel-seite	Lubrificazione int. opzionale Coolant through optional Innenkuehlung Optional	Lubrificazione est. Ext. coolant Aussenkuehlung	D
MNL0182500	3+3	X	X	X	25
MNL0182540	3+3	X	X	X	1"

DMG-MORI

NL1500/2000/2500/3000 12 STAZIONI - NLX1500/2000/2500/3000 12 STAZIONI - NLX4000 - NZL2000/2500 - NZX2500 (BMT60)
 NTX2000/2500/3000 2ND GEN. 10ST. - CTX2500 (BMT60)

PORTAUTENSILE ASSIALE PER BARENO 3+3 POSIZIONI Ø25mm / Ø1"

Axial 3+3 position boring bar holder Ø25mm / Ø1"

Axial Bohrhälter 3+3 Positionen Ø25mm / Ø1"

Subject to change without notice.

M.T. srl

Via Casino Albini 480
 Tel. 0541/956034-957884
 Fax 0541/956341

47842 S. GIOVANNI IN M. (RN)
 e-mail: mtma@mtmarchetti.com
 http://www.mtmarchetti.com



PAGINA MNL894-1-00

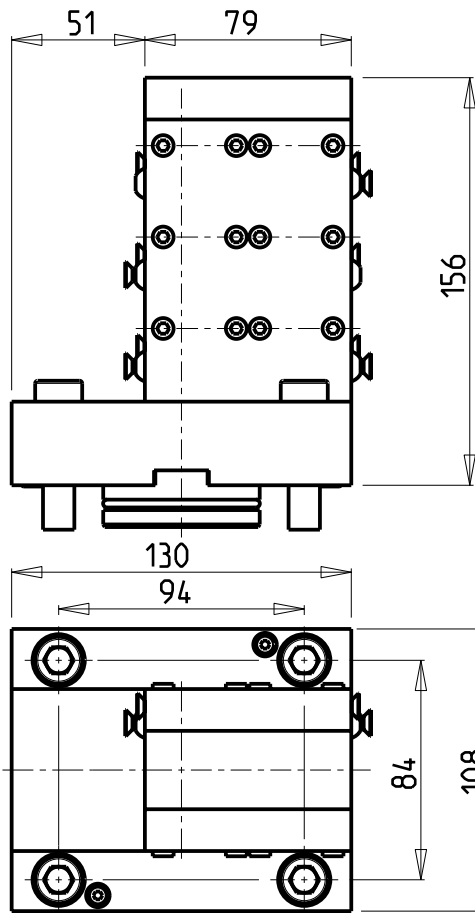
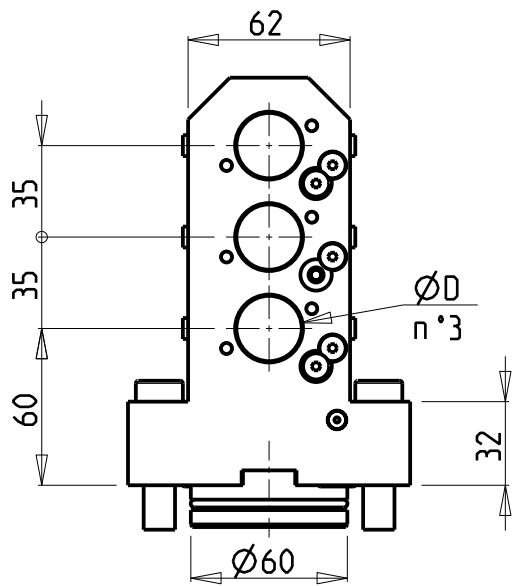

KIT ADDUZIONE INTERNA (OPZIONALE)
 KIT FOR INTERNAL COOLANT (OPTIONAL)
 KIT FUER INTERNE KUEHLMITTELZUFUHR (OPTIONAL)
 cod. KIT1000006

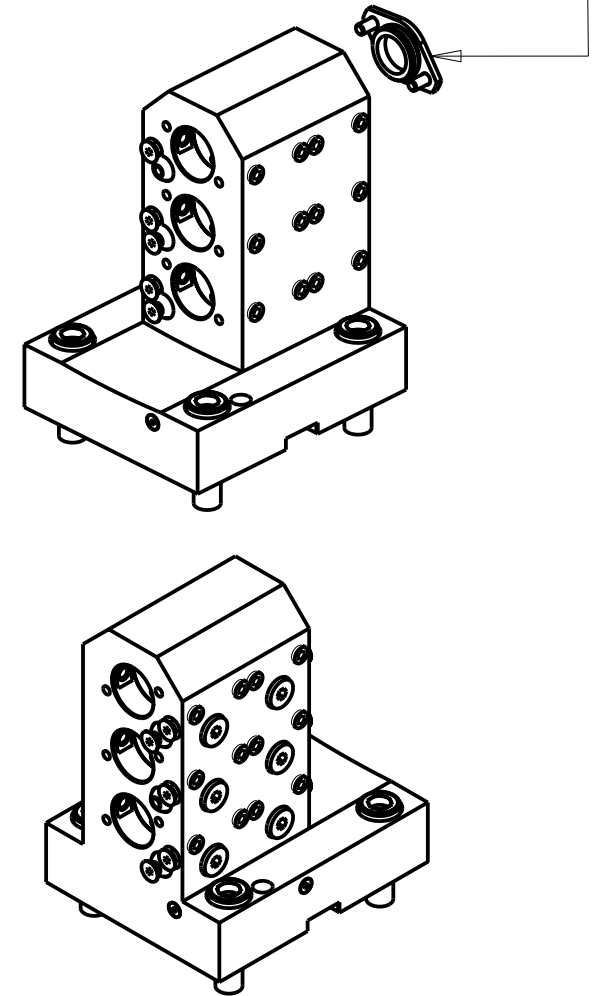

PER BOCCOLE DI RIDUZIONE VEDI PAG. TBL150-1-00
 FOR REDUCING BUSHINGS SEE PAGE TBL150-1-00
 FÜR REDUZIERBUCHSE SIEHE SEITE TBL150-1-00

Cod. MT	N°Utensili N°Tools N°Werkzeuge	Reversibile lato mandrino/contromandrino Reversible sub/main spindle side Umkehrbare Spindel-seite/ Gegenspindel-seite	Lubrificazione int. opzionale Coolant through optional Innenkuehlung Optional	Lubrificazione est. Ext. coolant Aussenkuehlung	D
MNL0192500	3	X	X	X	25
MNL0192540	3	X	X	X	1"

DMG-MORI

NL1500/2000/2500/3000 12 STAZIONI - NLX1500/2000/2500/3000 12 STAZIONI - NLX4000
 NTX2000/2500/3000 2ND GEN. 10ST. - CTX2500 (BMT60)

PORTAUTENSILE ASSIALE ARRETRATO PER BARENO 3 POSIZIONI Ø25mm / Ø1"

Axial 3 position rear set boring bar holder Ø25mm / Ø1"

Axial Bohrhälter 3 Positionen zurueckversetzt Ø25mm / Ø1"

Subject to change without notice.

M.T. srl

Via Casino Albini 480
 Tel. 0541/956034-957884
 Fax 0541/956341
 47842 S. GIOVANNI IN M. (RN)
 e-mail: mtma@mtmarchetti.com
 http://www.mtmarchetti.com



PAGINA MNL904-1-00

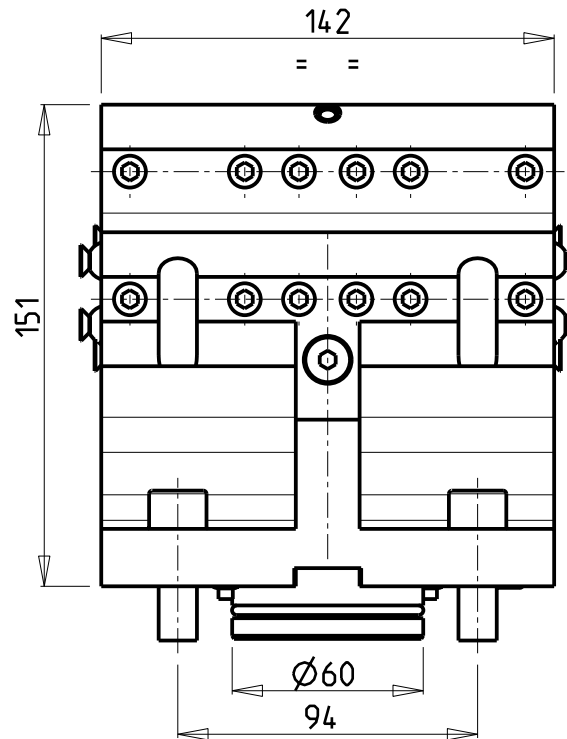
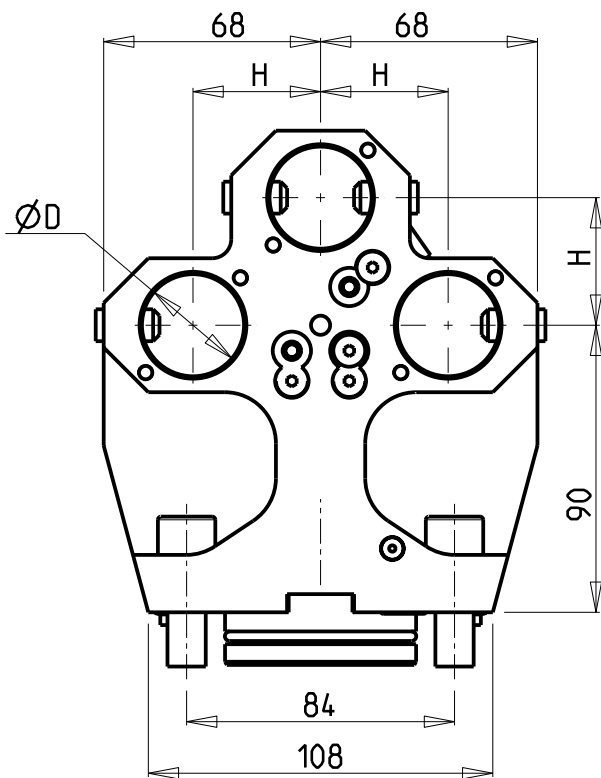

KIT ADDUZIONE INTERNA (OPZIONALE)
 KIT FOR INTERNAL COOLANT (OPTIONAL)
 KIT FUER INTERNE KUEHLMITTELZUFUHR (OPTIONAL)
 cod. KIT1000001

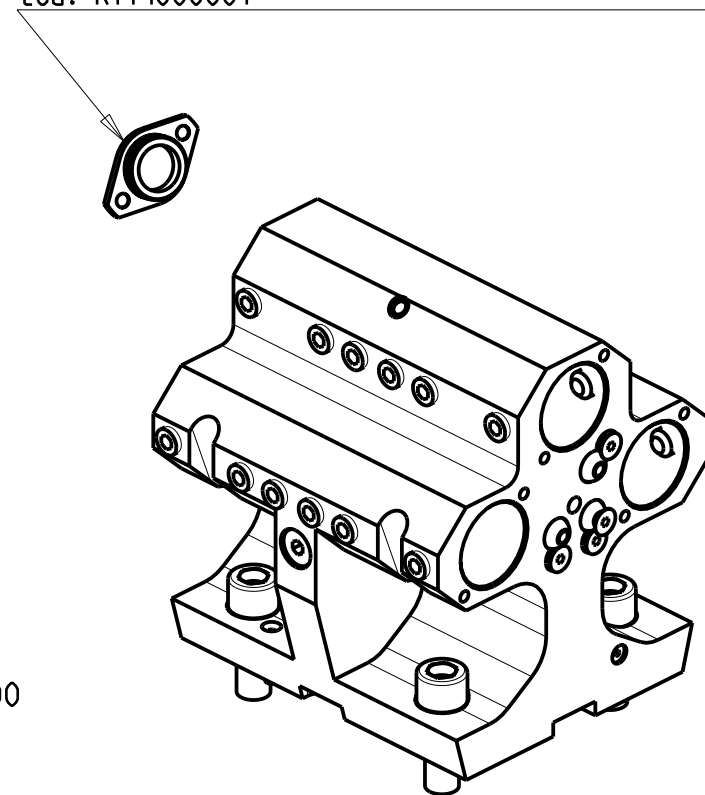

PER BOCCOLE DI RIDUZIONE VEDI PAG. TBL150-1-00
 FOR REDUCING BUSHINGS SEE PAGE TBL150-1-00
 FUR REDUZIERBUCHSE SIEHE SEITE TBL150-1-00

Cod. MT	N°Utensili N°Tools N°Werkzeuge	Lubrificazione int. Coolant through Innenkuehlung	Lubrificazione est. Ext. coolant Aussenkuehlung	Misure Dimensions Masse	D	H
MNL0093200	3+3	X	X	mm	32	40
MNL0093175	3+3	X	X	Inch	1 1/4"	1 1/2"

DMG-MORI

NL1500/2000/2500/3000 12 STAZIONI - NLX1500/2000/2500/3000 12 STAZIONI - NLX4000 - NZL2000/2500 - NZX2500 (BMT60)
 NTX2000/2500/3000 2ND GEN. 10ST. - CTX2500 (BMT60)

PORTAUTENSILE ASSIALE PER BARENO 3+3 POSIZIONI Ø32mm / Ø1 1/4"

Axial 3+3 position boring bar holder Ø32mm / Ø1 1/4"

Axial Bohrhalter 3+3 Positionen Ø32mm / Ø1 1/4"

Subject to change without notice.

M.T. srl

Via Casino Albini 480
 Tel. 0541/956034-957884
 Fax 0541/956341

47842 S. GIOVANNI IN M. (RN)
 e-mail: mtma@mtmarchetti.com
 http://www.mtmarchetti.com



PAGINA MNL912-1-00

ATTENZIONE - ATTENTION - ACHTUNG

- VERIFICARE LE MISURE DI INGOMBRO PER POSSIBILE INTERFERENZA
- Please check the overall sizes for possible interferences
- Bitte überprüfen sie das Ausmass um mögliche Interferenzen zu vermeiden

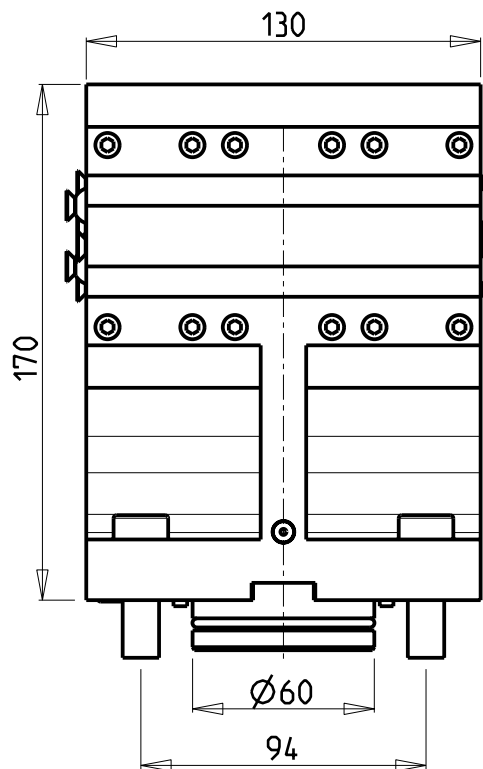
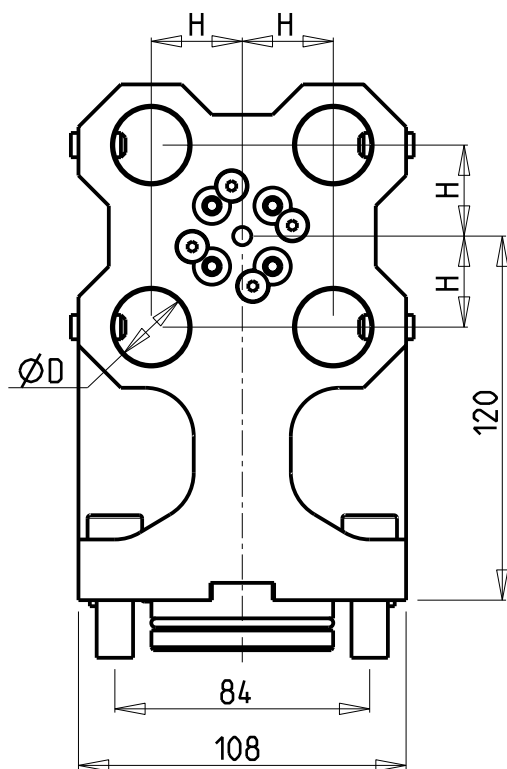

PER BOCCOLE DI RIDUZIONE VEDI PAG. TBL150-1-00
 FOR REDUCING BUSHINGS SEE PAGE TBL150-1-00
 FÜR REDUZIERBUCHSE SIEHE SEITE TBL150-1-00

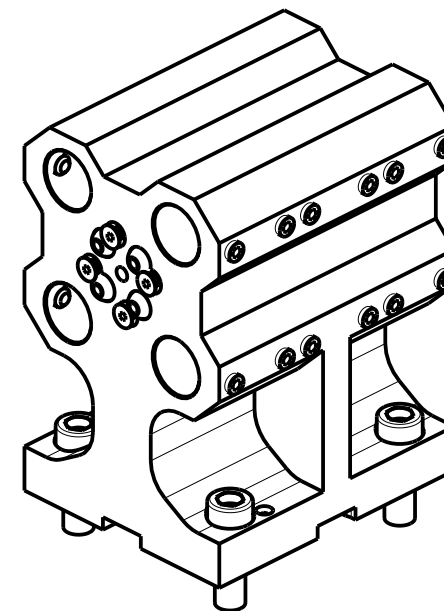

Cod. MT	N°Utensili N°Tools N°Werkzeuge	Lubrificazione est. Ext. coolant Aussenkuehlung	Misure Dimensions Masse	D	H
MNL0082500	4+4	X	mm	25	30
MNL0082540	4+4	X	Inch	1"	1 1/4"

DMG-MORI

NL1500/2000/2500/3000 12 STAZIONI - NLX1500/2000/2500/3000 12 STAZIONI - NLX4000 - CTX2500 (BMT60)

PORTAUTENSILE ASSIALE PER BARENO 4+4 POSIZIONI Ø25mm / Ø1"

Axial 4+4 position boring bar holder Ø25mm / Ø1"

Axial Bohrhälter 4+4 Positionen Ø25mm / Ø1"

Subject to change without notice.

M.T. srl

Via Casino Albini 480
 Tel. 0541/956034-957884
 Fax 0541/956341
 47842 S. GIOVANNI IN M. (RN)
 e-mail: mtma@mtmarchetti.com
 http://www.mtmarchetti.com



PAGINA MNL922-1-00

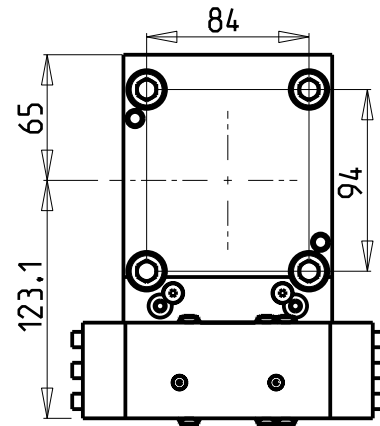
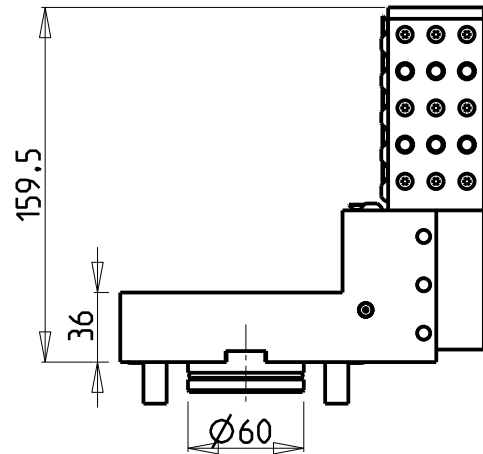
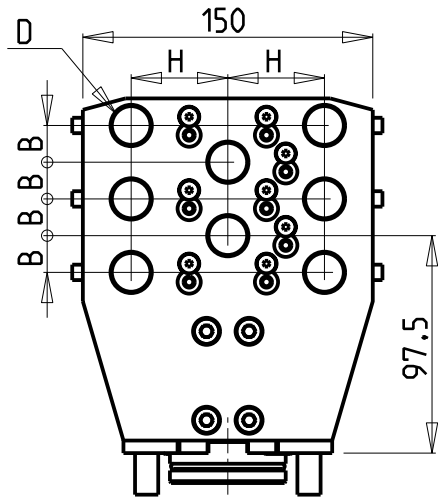

DOTAZIONI - SUPPLIED WITH - AUSSTATTUNG

mm	N*5 Boccole - Bushings - Buchsen Ø16-12-10-8-6 N*1 ER16 Portapinza - Collet holder - Zangenhalter N*1 ER25 Portapinza - Collet holder - Zangenhalter
inch	N*3 Boccole - Bushings - Buchsen Ø1/2"-3/8"-1/4" N*1 ER16 Portapinza - Collet holder - Zangenhalter N*1 ER25 Portapinza - Collet holder - Zangenhalter

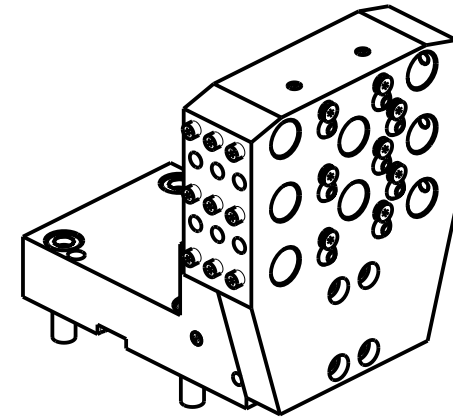

ATTENZIONE - ATTENTION - ACHTUNG

- VERIFICARE LE MISURE DI INGOMBRO PER POSSIBILE INTERFERENZA
- Please check the overall sizes for possible interferences
- Bitte überprüfen sie das Ausmass um mögliche Interferenzen zu vermeiden

Cod. MT	N°Utensili N°Tools N°Werkzeuge	Reversibile lato mandrino/contromandrino Reversible sub/main spindle side Umkehrbare Spindel-seite/ Gegenspindel-seite	Lubrificazione est. Ext. coolant Aussenkuehlung	Misure Dimensions Masse	D	B	H
MNL0122000	8	X	X	mm	20	16	50
MNL0121905	8	X	X	Inch	3/4"	5/8"	2"

DMG-MORI

NL1500/2000/2500/3000 12 STAZIONI - NLX1500/2000/2500/3000 12 STAZIONI - NLX4000 - CTX2500 (BMT60)

PORTAUTENSILE ASSIALE PER BARENO 8 POSIZIONI Ø20mm / Ø3/4"

Axial 8 position boring bar holder Ø20mm / Ø3/4"

Axial Bohrhälter 8 Positionen Ø20mm / Ø3/4"

Subject to change without notice.

M.T. srl

Via Casino Albini 480
Tel. 0541/956034-957884
Fax 0541/956341
47842 S. GIOVANNI IN M. (RN)
e-mail: mtma@mtmarchetti.com
http://www.mtmarchetti.com



PAGINA MNL933-1-00

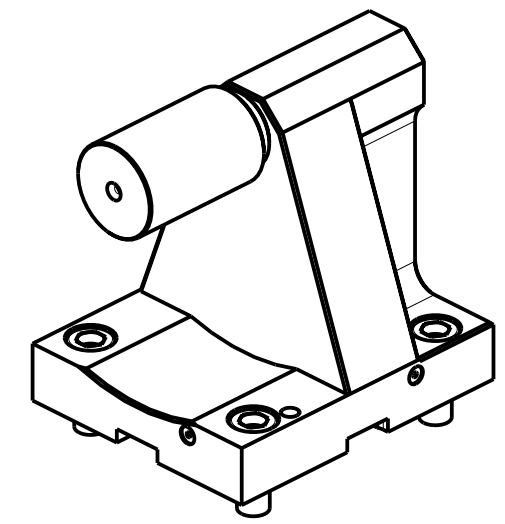
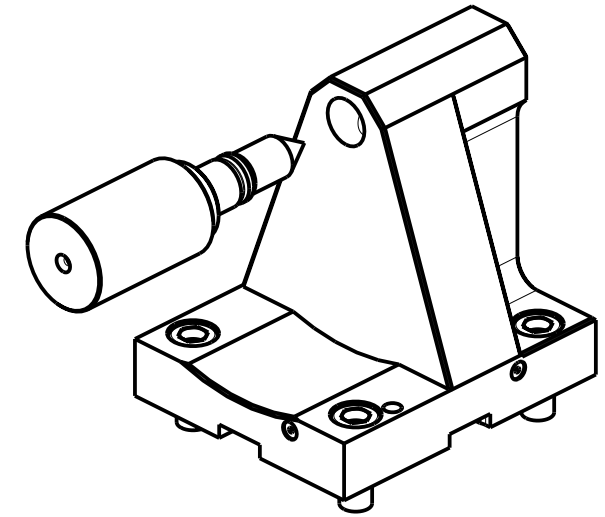
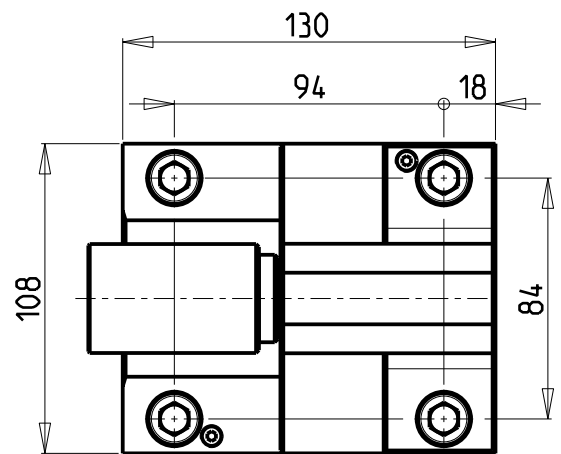
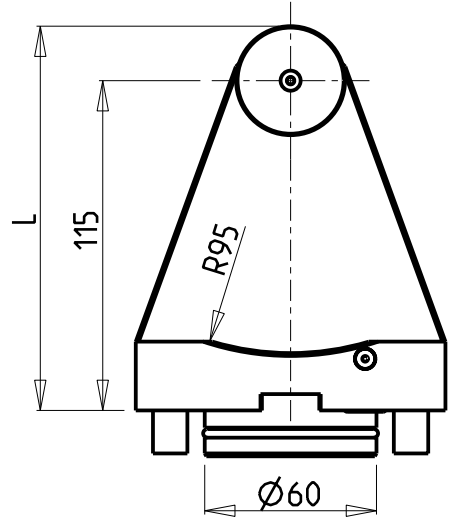
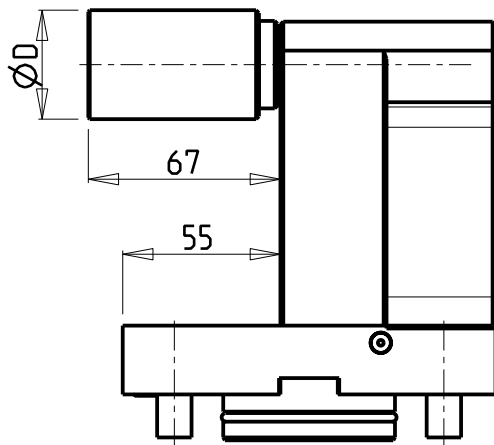

Cod. MT	N°Utensili N°Tools N°Werkzeuge	Reversibile lato mandrino/contromandrino Reversible sub/main spindle side Umkehrbare Spindelsete/ Gegenspindelsete	D	L
MNL0360100	1	X	38	134
MNL0360100L	1	X	2"	140.4

DMG-MORI

NL1500/2000/2500/3000 12 STAZIONI - NLX1500/2000/2500/3000 12 STAZIONI - NLX4000 - NZL2000/2500 - NZX2500 (BMT60)
 NT4200/4250/4300/5400 - NTX2000/2500/3000 2ND GEN. 10ST. - CTX2500 (BMT60)

CONTROPUNTA PER CONTROMANDRINO

Tailstock for subspindle
 Gegenspintz fuer Gegenspindel

Subject to change without notice.

M.T. srl

Via Casino Albini 480
 Tel. 0541/956034-957884
 Fax 0541/956341
 47842 S. GIOVANNI IN M. (RN)
 e-mail: mtma@mtmarchetti.com
 http://www.mtmarchetti.com



PAGINA MNL950-1-00

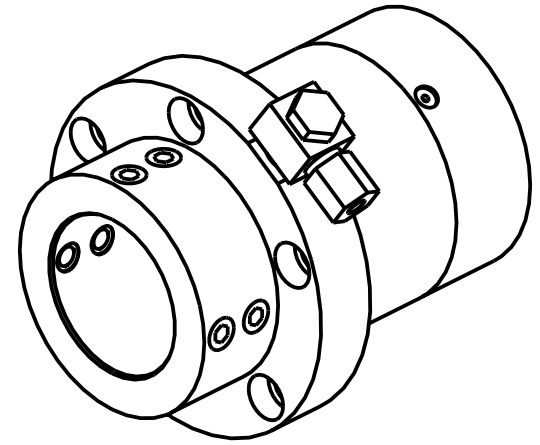
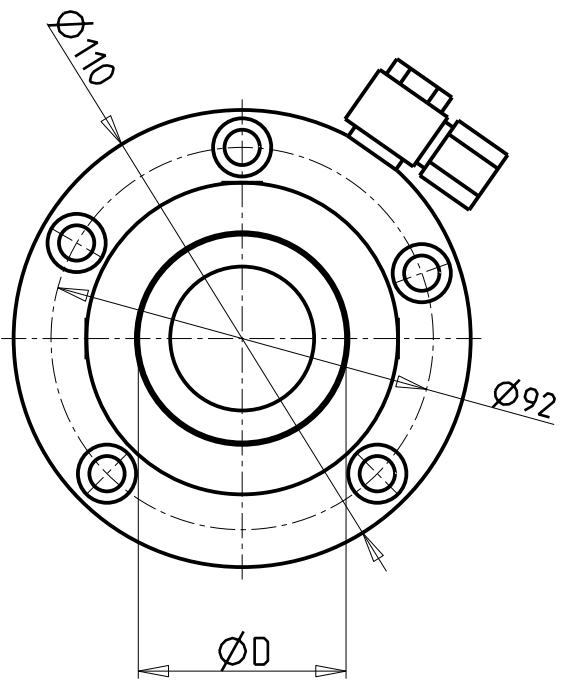
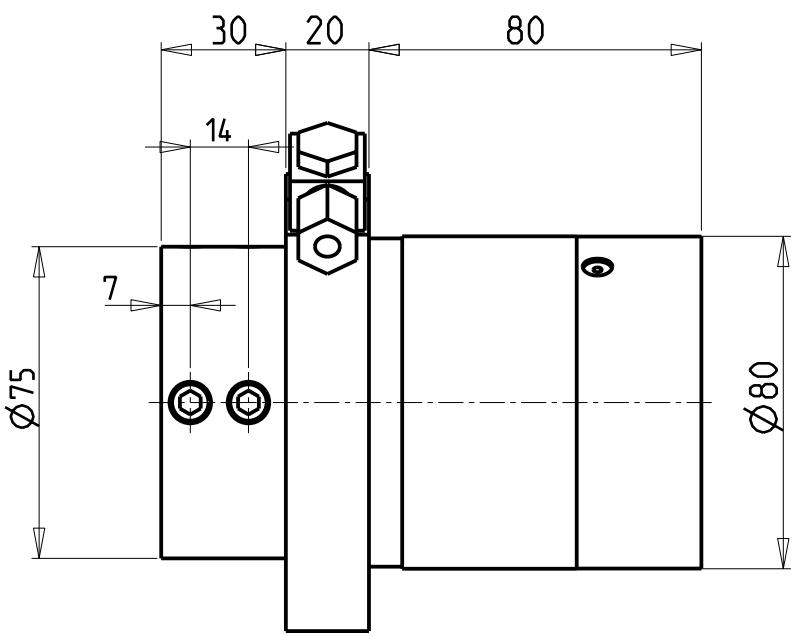

PER BOCCOLE DI RIDUZIONE VEDI PAG. TBL150-1-00
 FOR REDUCING BUSHINGS SEE PAGE TBL150-1-00
 FÜR REDUZIERBUCHSE SIEHE SEITE TBL150-1-00

Cod. MT	Lubrificazione int. Coolant through Innenkühlung	ØD
MNL0285000	X	50
MNL0285080	X	2"

DMG-MORI
 NL1500/2000/2500
 ADATTATORE CONTROPUNTA (DISTANZA PUNTE 700mm)
 Tailstock adapter (700mm drill head distance)
 Gegenspitz-Adapter (Spitzabstand 700mm)

M.T. srl
 Via Casino Albini 480
 Tel. 0541/956034-957884
 Fax 0541/956341
 47842 S. GIOVANNI IN M. (RN)
 e-mail: mtma@mtmarchetti.com
 http://www.mtmarchetti.com



PAGINA MNL955-1-00

Subject to change without notice.

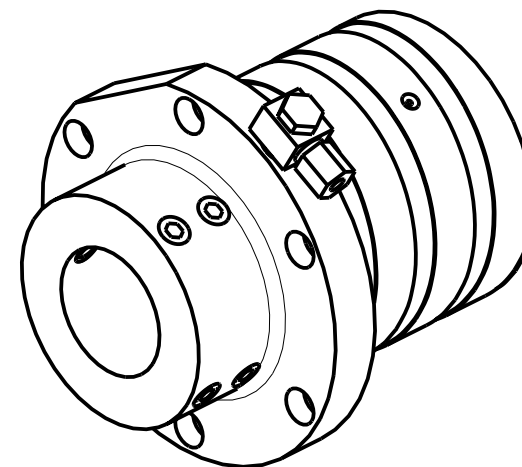
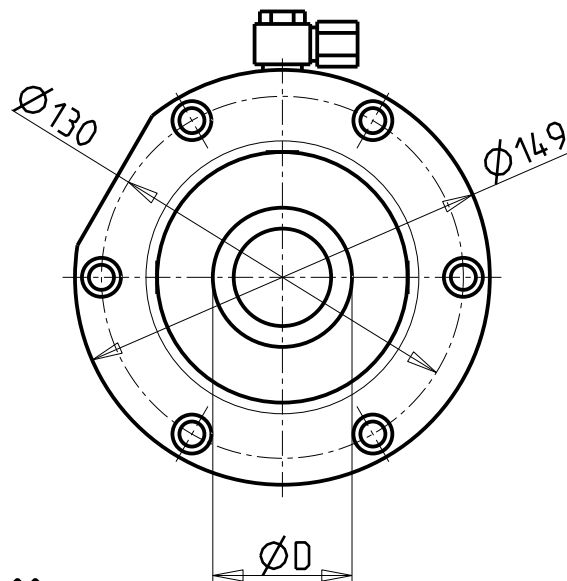
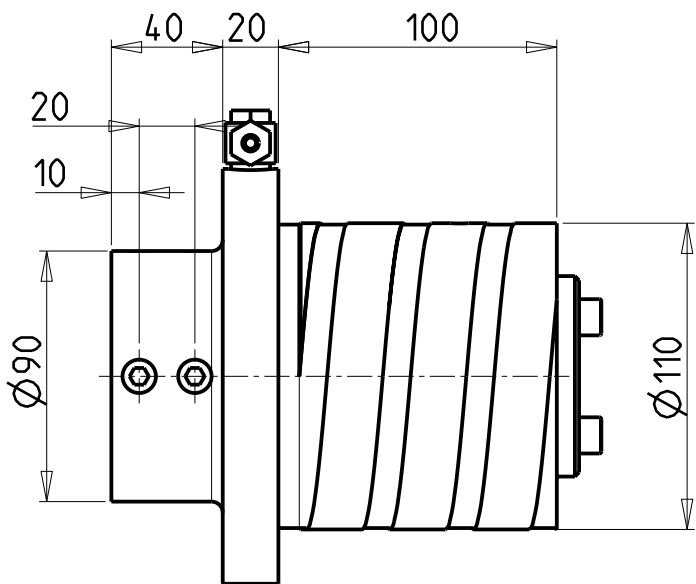

PER BOCCOLE DI RIDUZIONE VEDI PAG. TBL150-1-00
 FOR REDUCING BUSHINGS SEE PAGE TBL150-1-00
 FÜR REDUZIERBUCHSE SIEHE SEITE TBL150-1-00

Cod. MT	Lubrificazione int. Coolant through Innenkuehlung	ØD
MNL0275000	X	50
MNL0275080	X	2"

DMG-MORI
 NL2500/3000

ADATTATORE CONTROPUNTA (DISTANZA PUNTE 1250mm)
 Tailstock adapter (1250mm drill head distance)
 Gegenspitz-Adapter (Spitzabstand 1250mm)

Subject to change without notice.

M.T. srl

Via Casino Albini 480
 Tel. 0541/956034-957884
 Fax 0541/956341
 47842 S. GIOVANNI IN M. (RN)
 e-mail: mtma@mtmarchetti.com
 http://www.mtmarchetti.com



PAGINA MNL960-1-00

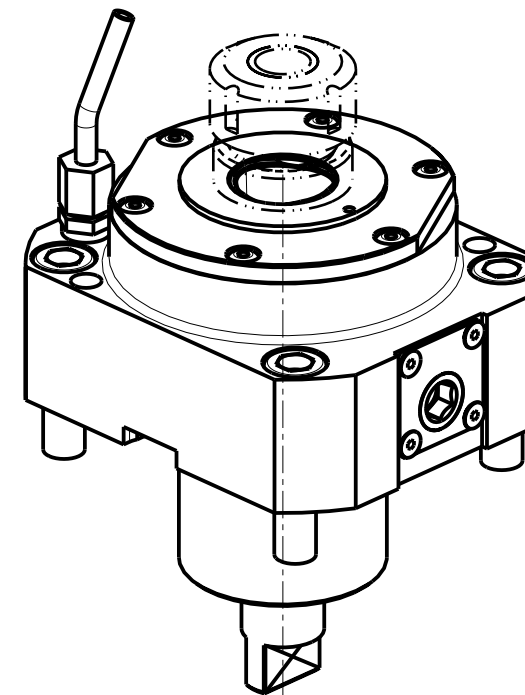
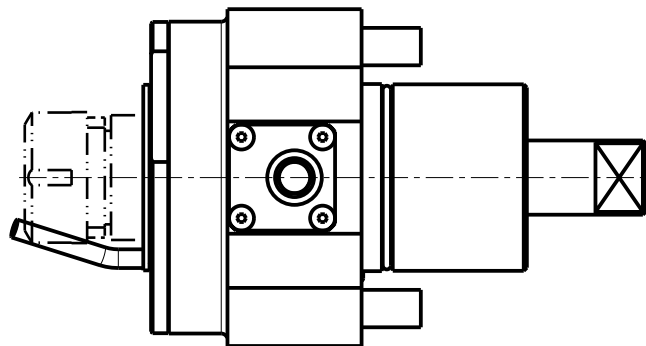
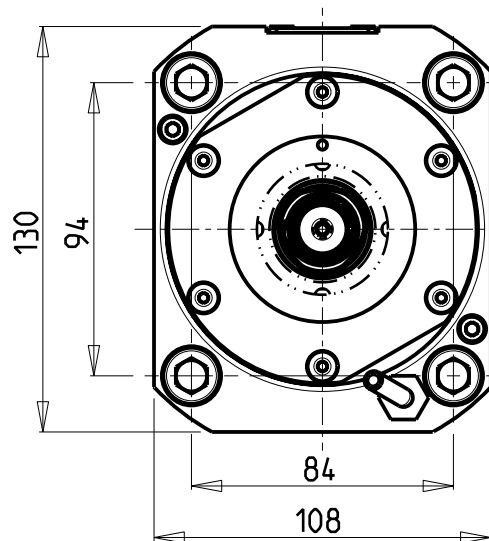
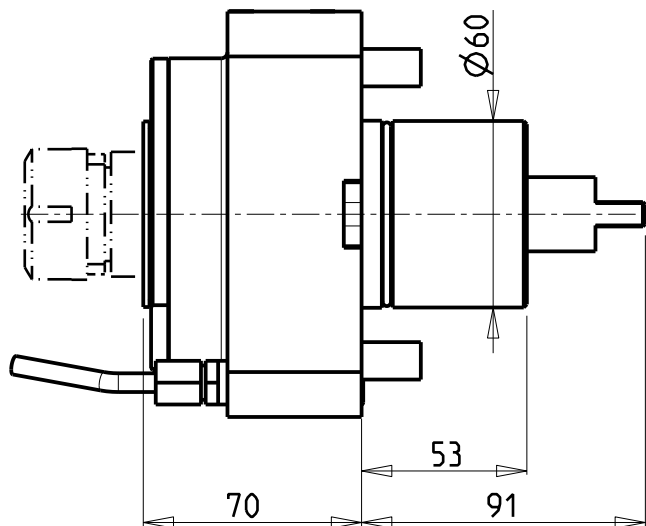

Cod. MT	TAGLIA Size Masse	I	RPM	Coppia Max Max Torque Max Drehmoment	Lubr.esterna Ext. coolant Aussenkuehlung
MNL0530140	C4	1:1	6000	100Nm	X
MNL0530150	C5	1:1	6000	100Nm	X

DMG-MORI

NL1500/2000/2500/3000 12 STAZIONI - NLX1500/2000/2500/3000 12 STAZIONI - NLX4000 - NZL2000/2500 - NZX2500 (BMT60)
 NT4200/4250/4300/5400 - NTX2000/2500/3000 2ND GEN. 10ST. - CTX2500 (BMT60)

MODULO MOTORIZZATO RADIALE MT CAPTO

Radial driven tool MT CAPTO

Radial angetriebenes Werkzeug MT CAPTO

Subject to change without notice.

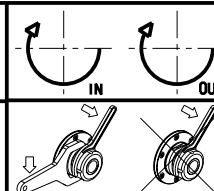

M.T. srl

Via Casino Albini 480
 Tel. 0541/956034-957884
 Fax 0541/956341
 47842 S. GIOVANNI IN M. (RN)
 e-mail: mtma@mtmarchetti.com
 http://www.mtmarchetti.com



PAGINA MNL010-A-40

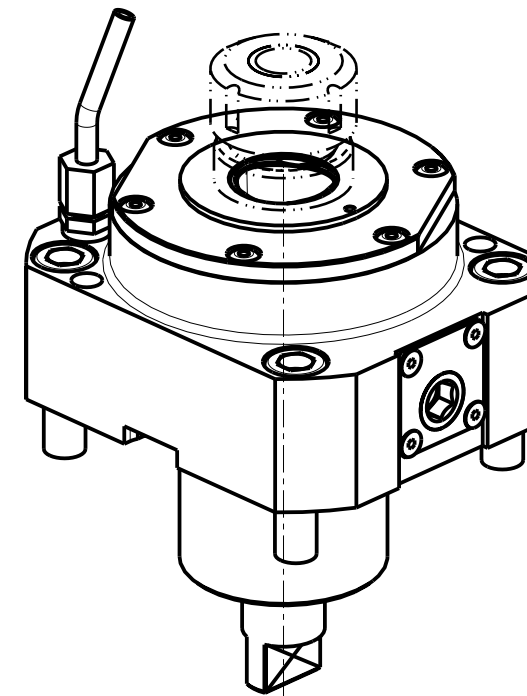
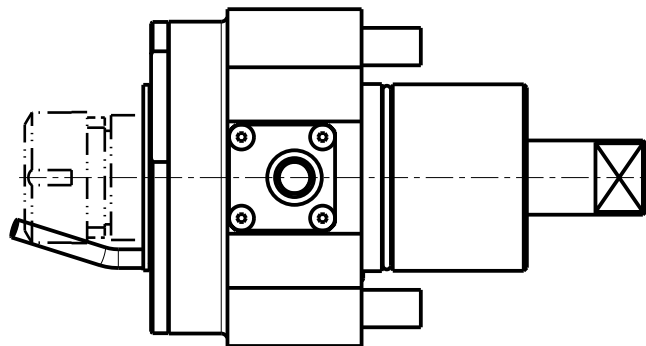
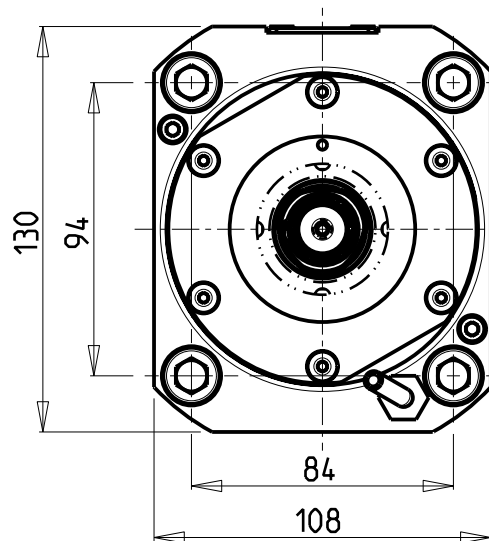
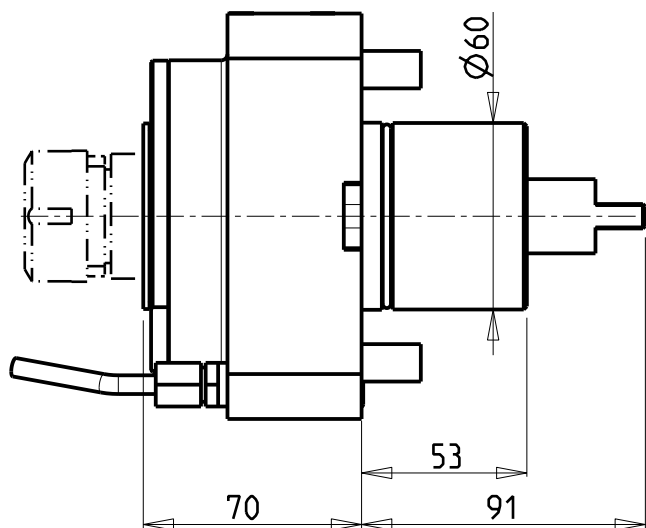

Cod. MT	TAGLIA Size Masse	I	RPM	Coppia Max Max Torque Max Drehmoment	Lubr.esterna Ext. coolant Aussenkuehlung
MNL0810140	C4	1:1	10000	100Nm	X
MNL0810150	C5	1:1	10000	100Nm	X

DMG-MORI

NL1500/2000/2500/3000 12 STAZIONI - NLX1500/2000/2500/3000 12 STAZIONI - NLX4000 - NZL2000/2500 - NZX2500 (BMT60)
 NT4200/4250/4300/5400 - NTX2000/2500/3000 2ND GEN. 10ST. - CTX2500 (BMT60)

MODULO MOTORIZZATO RADIALE 10000 RPM MT CAPTO

Radial driven tool 10000 rpm MT CAPTO

Radial angetriebenes Werkzeug 10000 rpm MT CAPTO

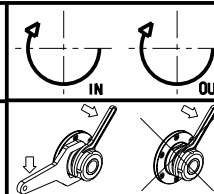

M.T. srl

Via Casino Albini 480
 Tel. 0541/956034-957884
 Fax 0541/956341
 47842 S. GIOVANNI IN M. (RN)
 e-mail: mtma@mtmarchetti.com
 http://www.mtmarchetti.com



PAGINA MNL010-A-41

Subject to change without notice.

10/2021

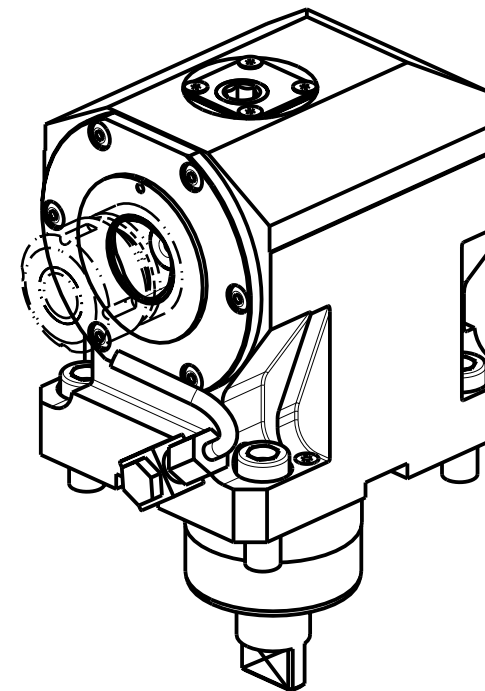
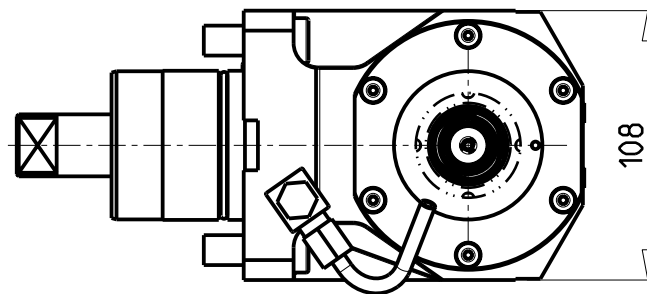
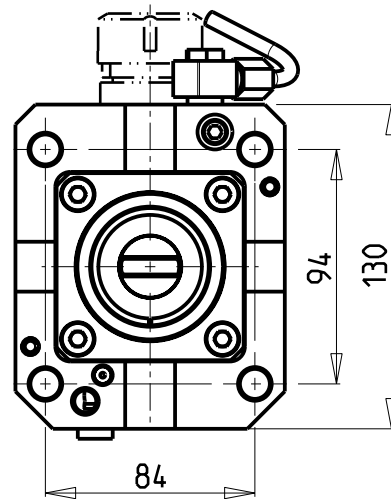
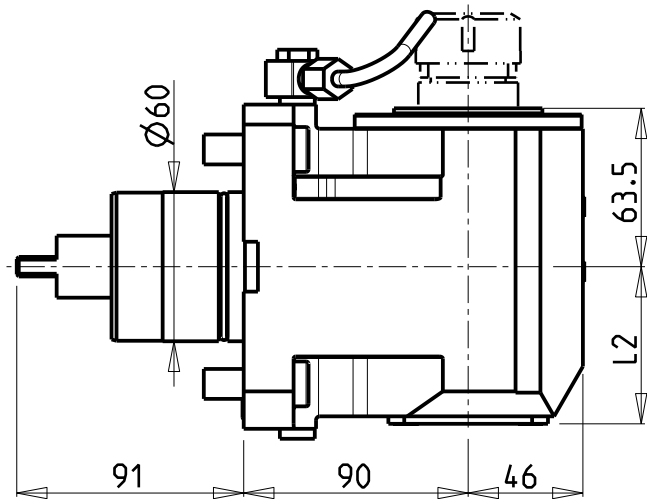

Cod. MT	TAGLIA Size Masse	i	RPM	Coppia Max Max Torque Max Drehmoment	Reversibile lato mandrino/contromandrino Reversible sub/main spindle side Umkehrbare Spindel-seite/ Gegenspindel-seite	Lubr.interna Coolant through Innenkuehlung	Lubr.esterna Ext. coolant Aussenkuehlung	L2
MNL0520140	C4	1:1	6000	100Nm	X	-	X	63
MNL0520240	C4	1:1	6000	100Nm	X	P=70bar	X	75.5
MNL0520150	C5	1:1	6000	100Nm	X	-	X	63
MNL0520250	C5	1:1	6000	100Nm	X	P=70bar	X	75.5

DMG-MORI

NL1500/2000/2500/3000 12 STAZIONI - NLX1500/2000/2500/3000 12 STAZIONI - NLX4000 - NZL2000/2500 - NZX2500 (BMT60)
NT4200/4250/4300/5400 - NTX2000/2500/3000 2ND GEN. 10ST. - CTX2500 (BMT60)

MODULO MOTORIZZATO ASSIALE MT CAPTO

Axial driven tool MT CAPTO

Axial angetriebenes Werkzeug MT CAPTO

Subject to change without notice.

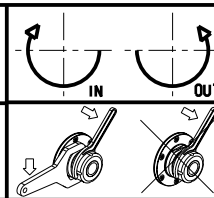

M.T. srl

Via Casino Albini 480
Tel. 0541/956034-957884
Fax 0541/956341

47842 S. GIOVANNI IN M. (RN)
e-mail: mtma@tmarchetti.com
http://www.tmmarchetti.com



PAGINA MNL150-A-40

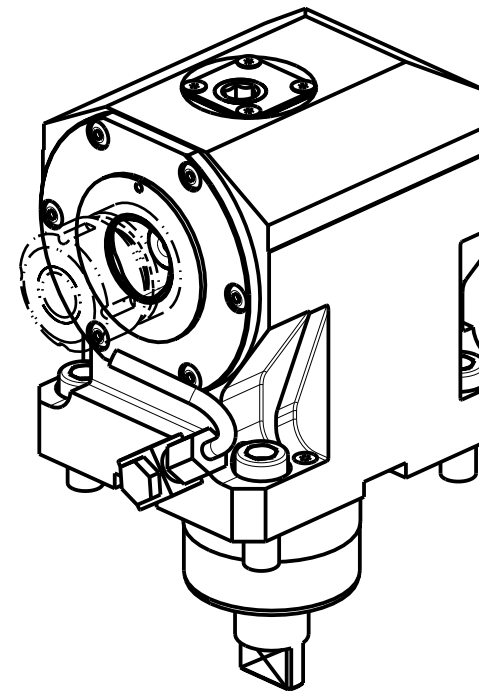
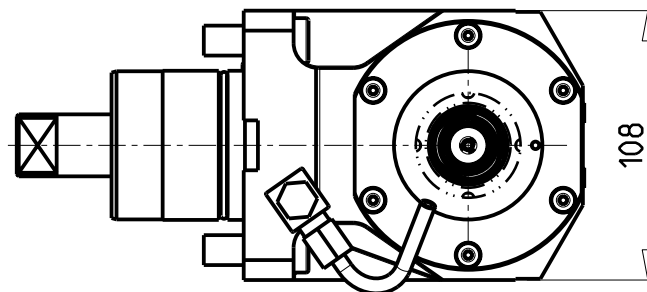
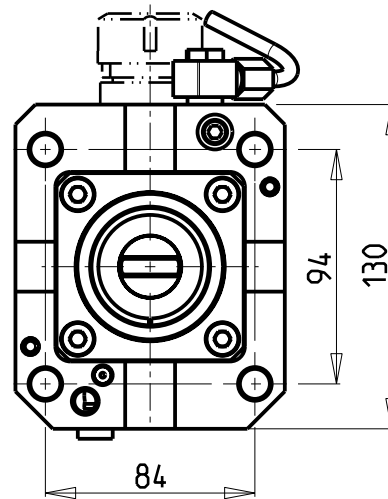
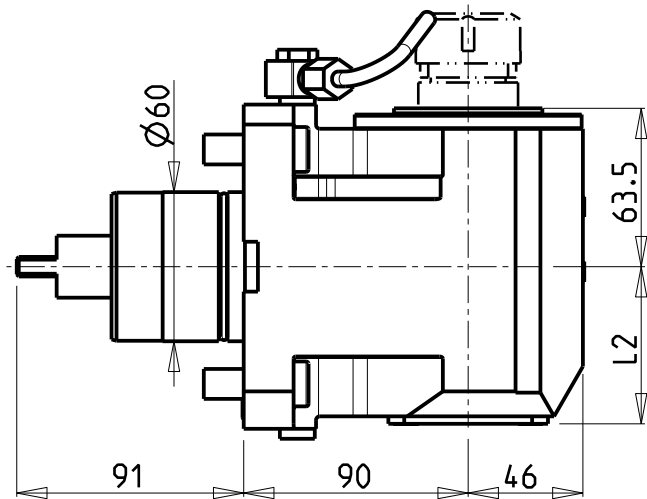

Cod. MT	TAGLIA Size Masse	I	RPM	Coppia Max Max Torque Max Drehmoment	Reversibile lato mandrino/contromandrino Reversible sub/main spindle side Umkehrbare Spindel-seite/ Gegenspindel-seite	Lubr.interna Coolant through Innenkuehlung	Lubr.esterna Ext. coolant Aussenkuehlung	L2
MNL0800140	C4	1:1	10000	100Nm	X	-	X	63
MNL0800240	C4	1:1	10000	100Nm	X	P=70bar	X	75.5
MNL0800150	C5	1:1	10000	100Nm	X	-	X	63
MNL0800250	C5	1:1	10000	100Nm	X	P=70bar	X	75.5

DMG-MORI

NL1500/2000/2500/3000 12 STAZIONI - NLX1500/2000/2500/3000 12 STAZIONI - NLX4000 - NZL2000/2500 - NZX2500 (BMT60)
 NT4200/4250/4300/5400 - NTX2000/2500/3000 2ND GEN. 10ST. - CTX2500 (BMT60)

MODULO MOTORIZZATO ASSIALE 10000 RPM MT CAPTO

Axial driven tool 10000 rpm MT CAPTO

Axial angetriebenes Werkzeug 10000 rpm MT CAPTO

Subject to change without notice.

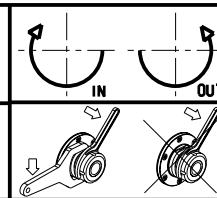

M.T. srl

Via Casino Albini 480
 Tel. 0541/956034-957884
 Fax 0541/956341
 47842 S. GIOVANNI IN M. (RN)
 e-mail: mtma@mtmarchetti.com
 http://www.mtmarchetti.com



PAGINA MNL150-A-41

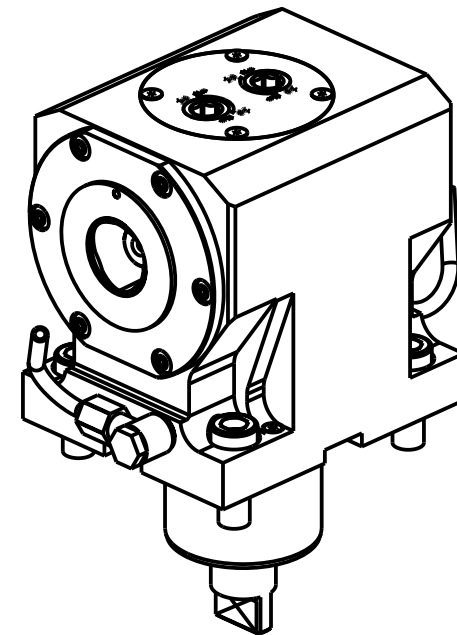
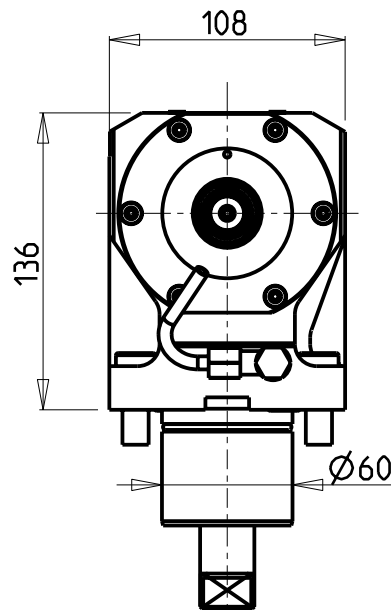
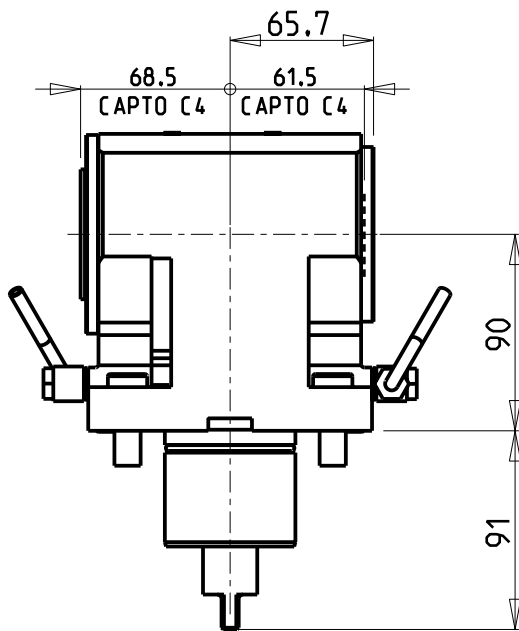
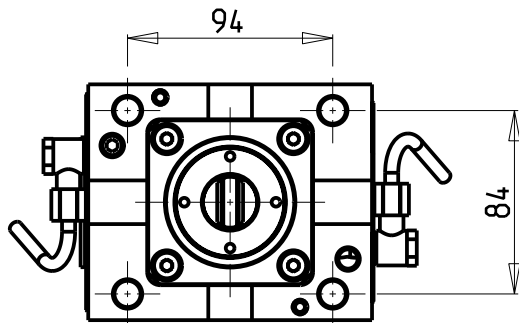

Cod. MT	TAGLIA Size Masse	I	RPM	Coppia Max Max Torque Max Drehmoment	Reversibile lato mandrino/contromandrino Reversible sub/main spindle side Umkehrbare Spindel-seite/ Gegenspindel-seite	Lubr.esterna Ext. coolant Aussenkuehlung
MNL1170240	C4+C4	1:1	10000	100Nm	X	X

DMG-MORI

NL1500/2000/2500/3000 12 STAZIONI - NLX1500/2000/2500/3000 12 STAZIONI - NLX4000 - NZL2000/2500 - NZX2500 (BMT60)
NT4200/4250/4300/5400 - CTX2500 (BMT60)

MODULO MOTORIZZATO ASSIALE BISPORGENTE 10000 RPM MT CAPTO

Axial opposite face twin driven tool 10000 rpm MT CAPTO

Axial angetriebenes Werkzeug halb vorspringend 10000 rpm mit MT CAPTO

Subject to change without notice.

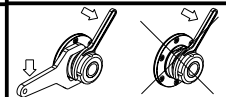

M.T. srl

Via Casino Albini 480
Tel. 0541/956034-957884
Fax 0541/956341

47842 S. GIOVANNI IN M. (RN)
e-mail: mtma@mtmarchetti.com
http://www.mtmarchetti.com



PAGINA MNL240-A-41

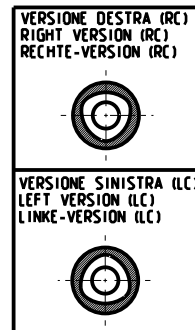
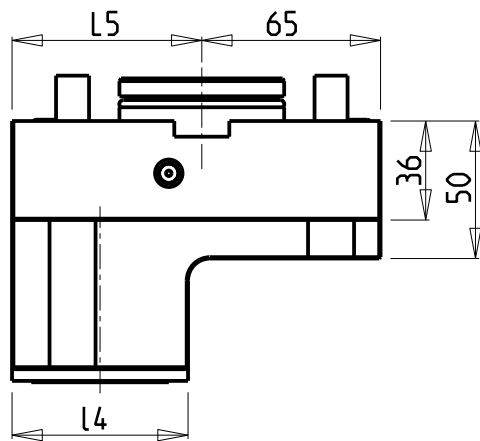
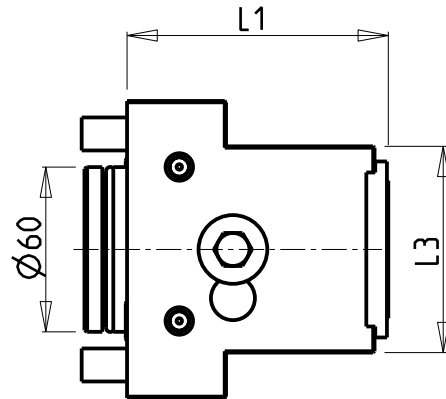
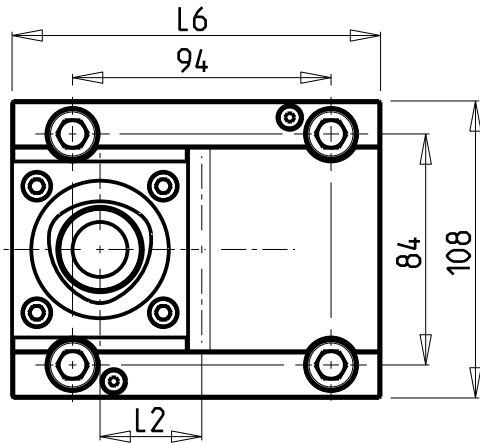

PER ORDINARE LA VERSIONE SX
AGGIUNGERE "LC" AL CODICE IN TABELLA.
ES: MNL0464010 DIVENTA MNL0464010LC

TO ORDER LEFT VERSION
ADD A "LC" IN THE CODE-CHARTS.
EXAMPLE: MNL0464010 BECOMES MNL0464010LC

UM DIE LINKE-VERSION ZU BESTELLEN, BEI DER
ARTIKELBEZEICHNUNG "LC" HINZUFUEGEN.
BEISPIEL: MNL0464010 WIRD DANN MNL0464010LC

ATTENZIONE - ATTENTION - ACHTUNG

-il cod. MNL0465015 è indicato per le lavorazioni su mandrino nelle macchine NT e su contromandrino nelle macchine NL

-it is advisable to use the tool MNL0465015 on NT machines for machinings on main spindle and on NL machines for machinings on sub-spindle

-Den Artikel MNL0465015 empfehlen wir fuer Verarbeitungen auf Hauptspindeln von NT Maschinen und auf Gegenspindeln von NL Maschinen

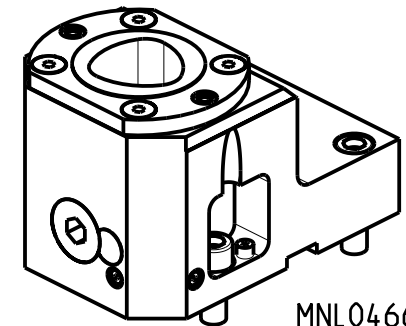
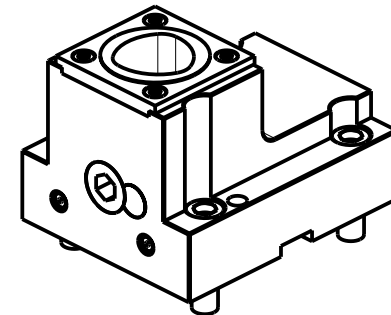

MNL0466010

Cod. MT	N°Utensili N°Tools N°Werkzeuge	Lubrificazione int. Coolant through Innenkuehlung	Reversibile lato mandrino/contromandrino Reversible sub/main spindle side Umkehrbare Spindel-seite/ Gegenspindel-seite	TAGLIA Size Masse	L1	L2	L3	L4	L5	L6
MNL0464010	1	X	X	C4	90	45	63	48	69	134
MNL0465010	1	X	X	C5	95	37	75	64	69	134
MNL0465015	1	X	X	C5	95	62.5	75	64	94.5	159.5
MNL0466010	1	X	X	C6	108	55	108	94	97	162

DMG-MORI

NL1500/2000/2500/3000 12 STAZIONI - NLX1500/2000/2500/3000 12 STAZIONI - NLX4000 - NZL2000/2500 - NZX2500 (BMT60)
NT4200/4250/4300/5400 - NTX2000/2500/3000 2ND GEN. 10ST. - CTX2500 (BMT60)

PORTAUTENSILE RADIALE SINGOLO MT CAPTO

Radial single static tool MT CAPTO

Radial Single-Werkzeughalter MT CAPTO

Subject to change without notice.

M.T. srl

Via Casino Albini 480
Tel. 0541/956034-957884
Fax 0541/956341
47842 S. GIOVANNI IN M. (RN)
e-mail: mtma@mtmarchetti.com
http://www.mtmarchetti.com



PAGINA MNL420-A-40

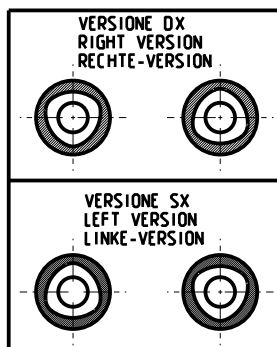
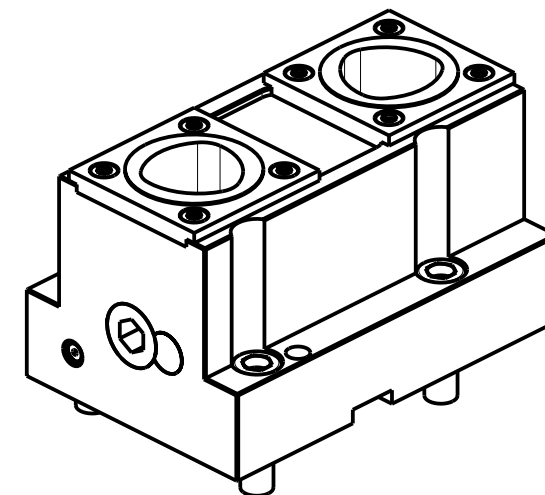
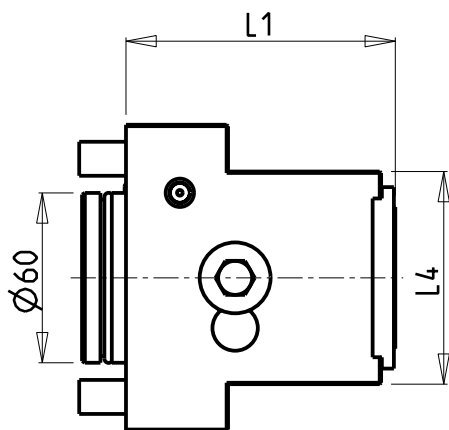
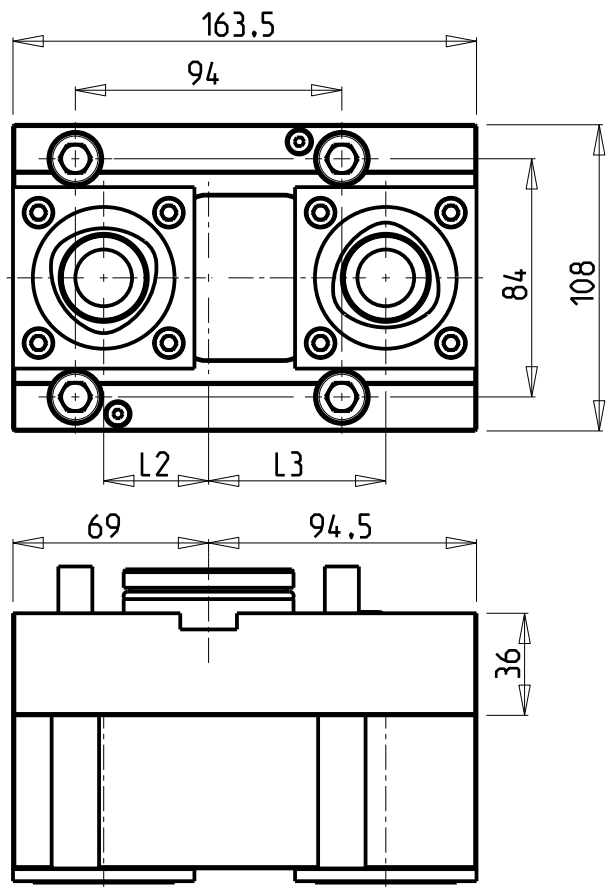

PER ORDINARE LA VERSIONE SX
AGGIUNGERE "LC" AL CODICE IN TABELLA.
ES: MNL0464010 DIVENTA MNL0464010LC

TO ORDER LEFT VERSION
ADD A "LC" IN THE CODE-CHARTS.
EXAMPLE: MNL0464010 BECOMES MNL0464010LC

UM DIE LINKE-VERSION ZU BESTELLEN, BEI DER
ARTIKELBEZEICHNUNG "LC" HINZUFUEGEN.
BEISPIEL: MNL0464010 WIRD DANN MNL0464010LC

Cod. MT	N°Utensili N°Tools N°Werkzeuge	Lubrificazione int. Coolant through Innenkuehlung	TAGLIA Size Masse	L1	L2	L3	L4
MNL0474020	2	X	C4	90	45	70.5	63
MNL0475020	2	X	C5	95	37	62.5	75

DMG-MORI

NL1500/2000/2500/3000 12 STAZIONI - NLX1500/2000/2500/3000 12 STAZIONI - NLX4000 - NZL2000/2500 - NZX2500 (BMT60)
NT4200/4250/4300/5400 - NTX2000/2500/3000 2ND GEN. 10ST. - CTX2500 (BMT60)

PORTAUTENSILE RADIALE DOPPIO MT CAPTO

Radial double static tool MT CAPTO

Radial Doppel-Werkzeughalter MT CAPTO

Subject to change without notice.

M.T. srl

Via Casino Albini 480
Tel. 0541/956034-957884
Fax 0541/956341
47842 S. GIOVANNI IN M. (RN)
e-mail: mtma@tmarchetti.com
http://www.tmmarchetti.com



PAGINA MNL450-A-40

10/2021

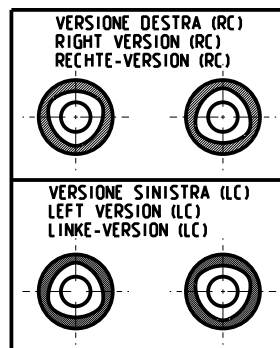
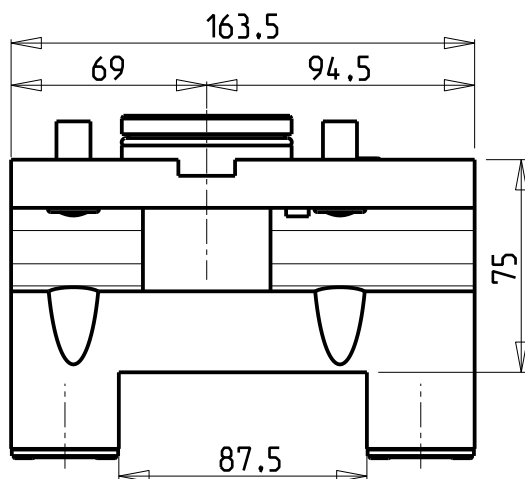
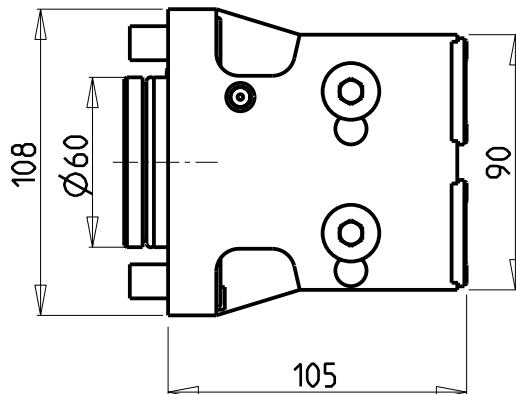
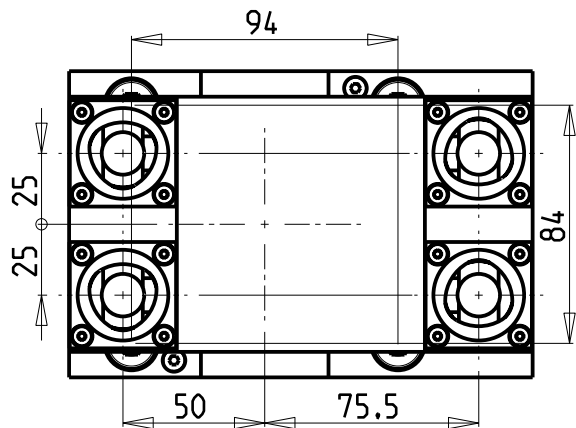

**PER ORDINARE LA VERSIONE SX
AGGIUNGERE "LC" AL CODICE IN TABELLA.
ES: MNL0464010 DIVENTA MNL0464010LC**

**TO ORDER LEFT VERSION
ADD A "LC" IN THE CODE-CHARTS.
EXAMPLE: MNL0464010 BECOMES MNL0464010LC**

**UM DIE LINKE-VERSION ZU BESTELLEN, BEI DER
ARTIKELBEZEICHNUNG "LC" HINZUFUEGEN.
BEISPIEL: MNL0464010 WIRD DANN MNL0464010LC**

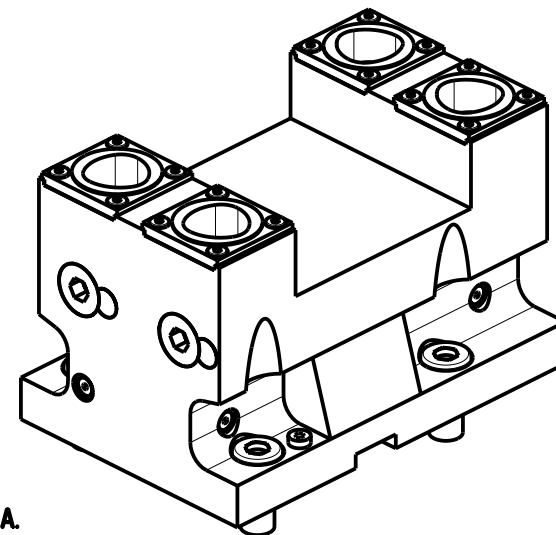

Cod. MT	N°Utensili N°Tools N°Werkzeuge	Lubrificazione int. Coolant through Innenkuehlung	TAGLIA Size Masse
MNL0483240	4	X	C3

DMG-MORI

NL1500/2000/2500/3000 12 STAZIONI - NLX1500/2000/2500/3000 12 STAZIONI - NLX4000 - NZL2000/2500 - NZX2500 (BMT60)
NT4200/4250/4300/5400 - NTX2000/2500/3000 2ND GEN. 10ST. - CTX2500 (BMT60)

PORTAUTENSILE RADIALE DOPPIO SOVRAPPOSTO 2+2 POS. MT CAPTO

Radial double 2+2 upright position static tool MT CAPTO

Radial Doppel-Werkzeughalter 2+2 Positionen ueberlagert MT CAPTO

Subject to change without notice.

M.T. srl

Via Casino Albini 480
Tel. 0541/956034-957884
Fax 0541/956341
47842 S. GIOVANNI IN M. (RN)
e-mail: mtma@mtmarchetti.com
http://www.mtmarchetti.com



PAGINA MNL460-A-30

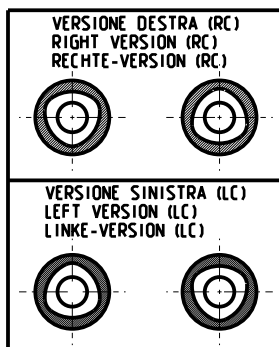
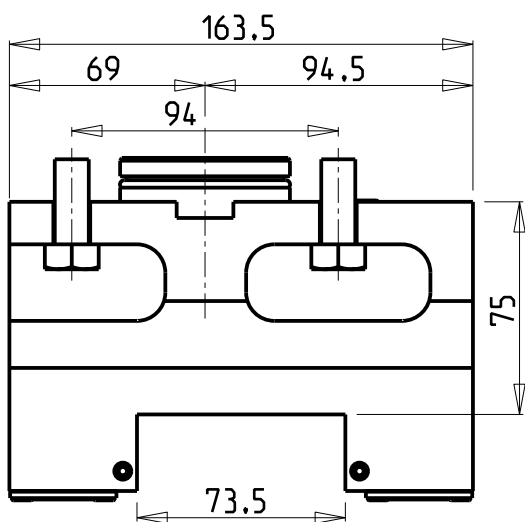
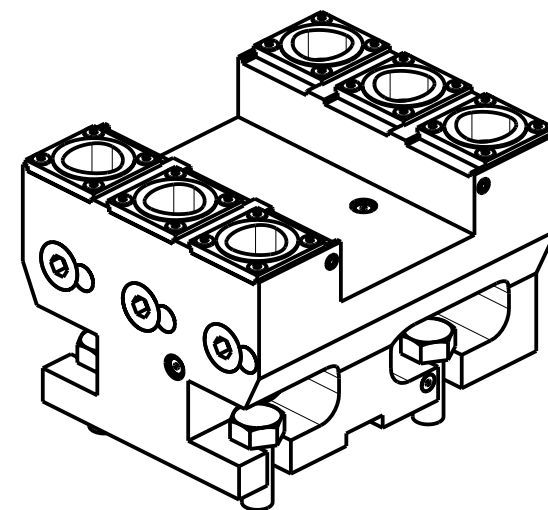
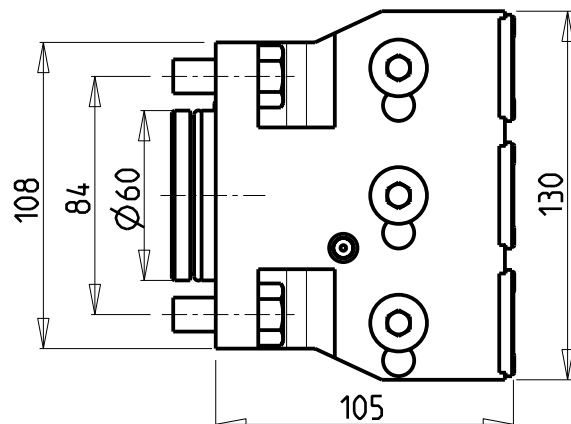
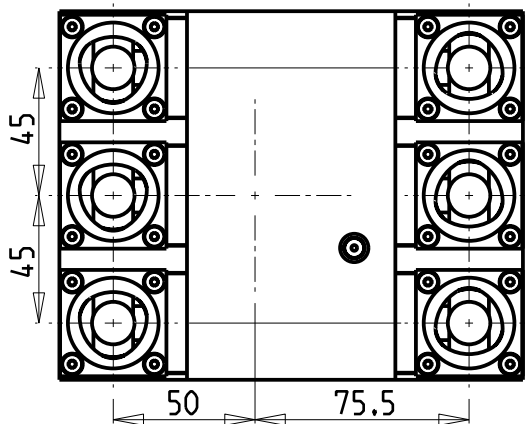

PER ORDINARE LA VERSIONE SX
AGGIUNGERE "LC" AL CODICE IN TABELLA.
ES: MNL0464010 DIVENTA MNL0464010LC

TO ORDER LEFT VERSION
ADD A "LC" IN THE CODE-CHARTS.
EXAMPLE: MNL0464010 BECOMES MNL0464010LC

UM DIE LINKE-VERSION ZU BESTELLEN, BEI DER
ARTIKELBEZEICHNUNG "LC" HINZUFUEGEN.
BEISPIEL: MNL0464010 WIRD DANN MNL0464010LC

Cod. MT	N°Utensili N°Tools N°Werkzeuge	Lubrificazione int. Coolant through Innenkuehlung	TAGLIA Size Masse
MNL0483260	6	X	C3

DMG-MORI

NL1500/2000/2500/3000 12 STAZIONI - NLX1500/2000/2500/3000 12 STAZIONI - NLX4000 - NZL2000/2500 - NZX2500 (BMT60)
NT4200/4250/4300/5400 - CTX2500 (BMT60)

PORTAUTENSILE RADIALE DOPPIO SOVRAPPOSTO 3+3 POSIZIONI MT CAPTO

Radial double 3+3 upright position static tool MT CAPTO

Radial Doppel-Werkzeughalter 3+3 Positionen ueberlagert MT CAPTO

Subject to change without notice.

M.T. srl

Via Casino Albini 480
Tel. 0541/956034-957884
Fax 0541/956341
47842 S. GIOVANNI IN M. (RN)
e-mail: mtma@mtmarchetti.com
http://www.mtmarchetti.com



PAGINA MNL465-A-30

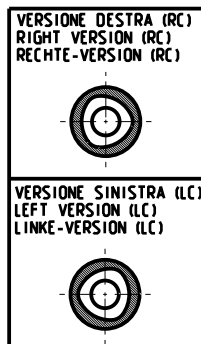
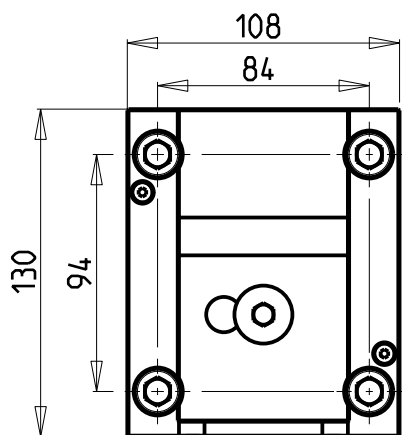
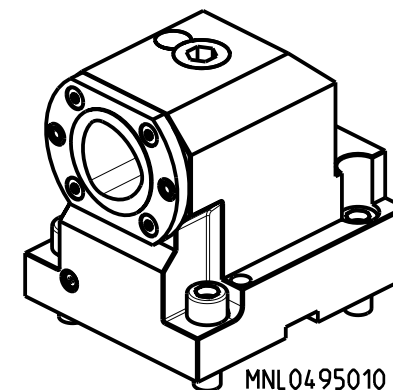
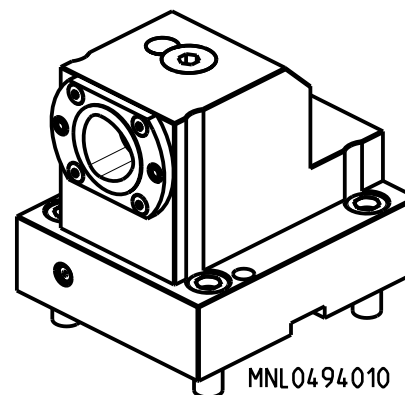
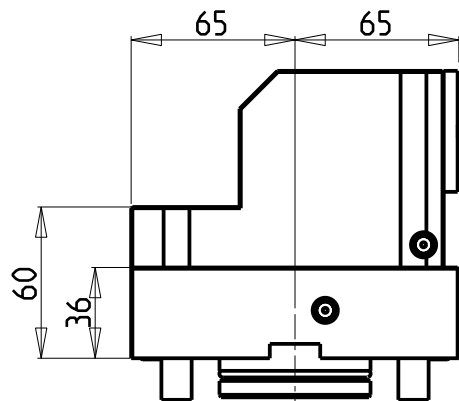
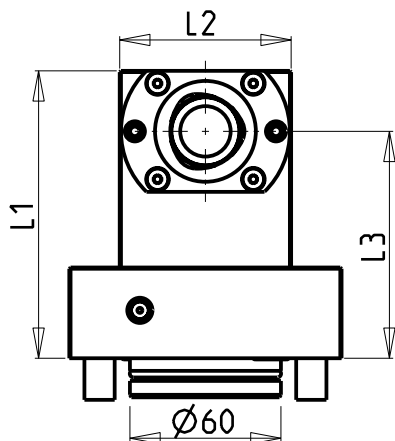

**PER ORDINARE LA VERSIONE SX
AGGIUNGERE "LC" AL CODICE IN TABELLA.
ES: MNL0464010 DIVENTA MNL0464010LC**

**TO ORDER LEFT VERSION
ADD A "LC" IN THE CODE-CHARTS.
EXAMPLE: MNL0464010 BECOMES MNL0464010LC**

**UM DIE LINKE-VERSION ZU BESTELLEN, BEI DER
ARTIKELBEZEICHNUNG "LC" HINZUFUEGEN.
BEISPIEL: MNL0464010 WIRD DANN MNL0464010LC**

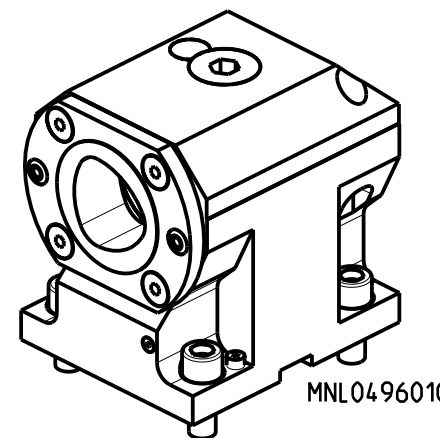

ATTENZIONE - ATTENTION - ACHTUNG

- utilizzare il cod. MNL0495015 per eseguire lavorazioni su macchine NT4000 serie
- use part number MNL0495015 for machinings on NT4000 series machines
- Bitte benutzen sie den MNL0495015 Artikel, um Arbeiten auf NT4000 Maschinen auszufuehren

Cod. MT	N°Utensili N°Tools N°Werkzeuge	Lubrificazione int. Coolant through Innenkuehlung	Reversibile lato mandrino/contromandrino Reversible sub/main spindle side Umkehrbare Spindel-seite/ Gegenspindel-seite	TAGLIA Size Masse	L1	L2	L3
MNL0494010	1	X	X	C4	114	68	90
MNL0495010	1	X	X	C5	122	83	90
MNL0495015	1	X	X	C5	152	83	120
MNL0496010	1	X	X	C6	132	108	90

DMG-MORI

NL1500/2000/2500/3000 12 STAZIONI - NLX1500/2000/2500/3000 12 STAZIONI - NLX4000 - NZL2000/2500 - NZX2500 (BMT60)
NT4200/4250/4300/5400 - NTX2000/2500/3000 2ND GEN. 10ST. - CTX2500 (BMT60)

PORTAUTENSILE ASSIALE SINGOLO MT CAPTO

Axial single static tool MT CAPTO

Axial Single-Werkzeughalter MT CAPTO

Subject to change without notice.

M.T. srl

Via Casino Albini 480
Tel. 0541/956034-957884
Fax 0541/956341
47842 S. GIOVANNI IN M. (RN)
e-mail: mtma@mtmarchetti.com
http://www.mtmarchetti.com



PAGINA MNL550-A-40

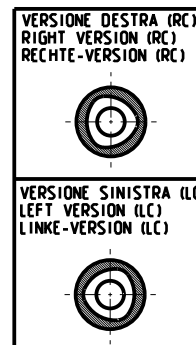
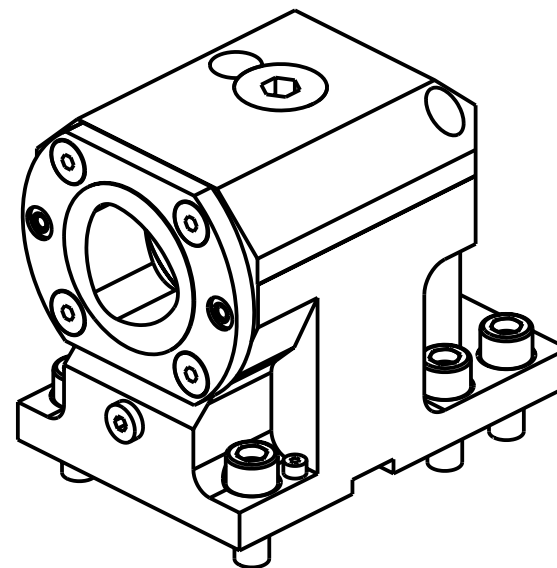
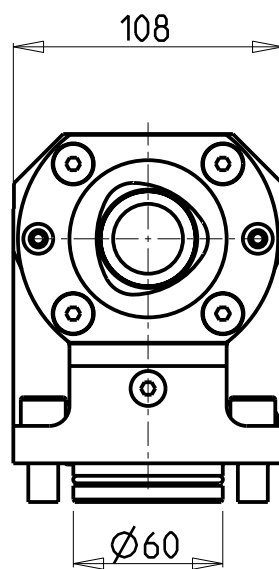
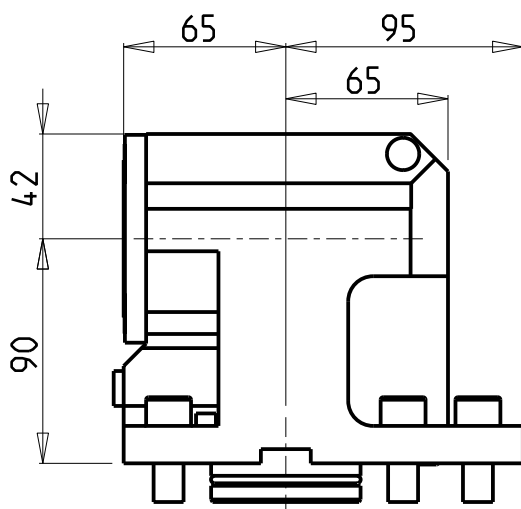
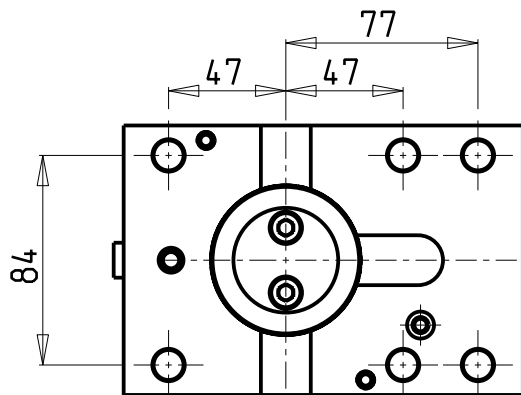

PER ORDINARE LA VERSIONE SX
AGGIUNGERE "LC" AL CODICE IN TABELLA.
ES: MNL1196010 DIVENTA MNL1196010LC

TO ORDER LEFT VERSION
ADD A "LC" IN THE CODE-CHARTS.
EXAMPLE: MNL1196010 BECOMES MNL1196010LC

UM DIE LINKE-VERSION ZU BESTELLEN, BEI DER
ARTIKELBEZEICHNUNG "LC" HINZUFUEGEN.
BEISPIEL: MNL1196010 WIRD DANN MNL1196010LC

Cod. MT	N°Utensili N°Tools N°Werkzeuge	Lubrificazione int. Coolant through Innenkuehlung	Lubrificazione est. Ext. coolant Aussenkuehlung	TAGLIA Size Masse
MNL1196010	1	X	X	C6

DMG-MORI
NLX2500 - NLX3000 - NLX4000 - CTX2500 (BMT60)

PORTAUTENSILE ASSIALE SINGOLO MT CAPTO
Axial single static tool MT CAPTO
Axial Single-Werkzeughalter MT CAPTO

Subject to change without notice.

M.T. srl
Via Casino Albini 480
Tel. 0541/956034-957884
Fax 0541/956341
47842 S. GIOVANNI IN M. (RN)
e-mail: mtma@mtmarchetti.com
http://www.mtmarchetti.com



PAGINA MNL552-A-60

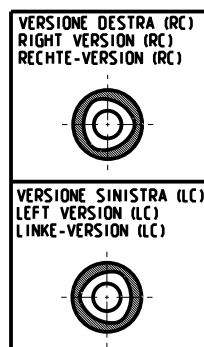
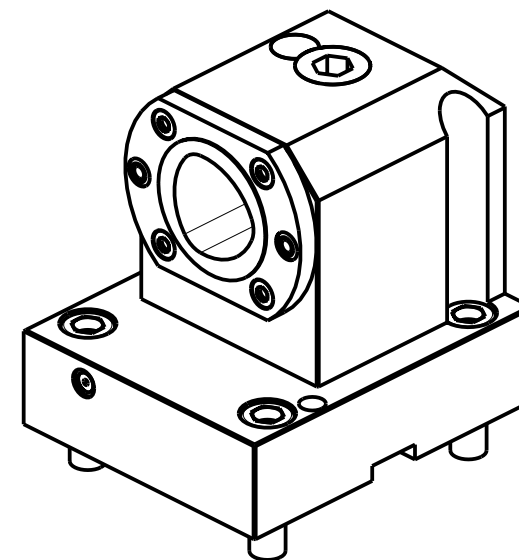
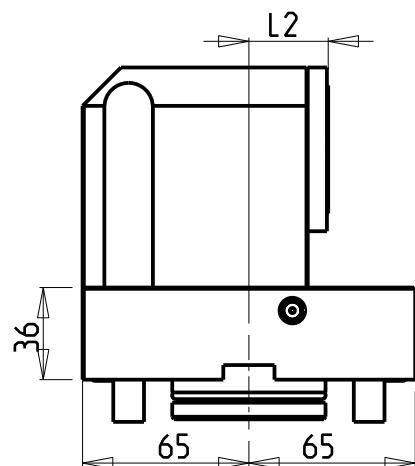
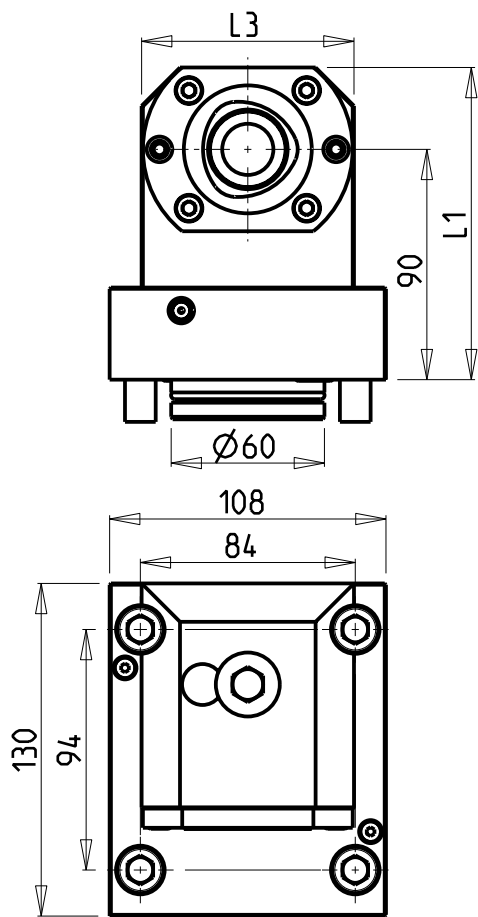

PER ORDINARE LA VERSIONE SX
AGGIUNGERE "LC" AL CODICE IN TABELLA.
ES: MNL0464010 DIVENTA MNL0464010LC

TO ORDER LEFT VERSION
ADD A "LC" IN THE CODE-CHARTS.
EXAMPLE: MNL0464010 BECOMES MNL0464010LC

UM DIE LINKE-VERSION ZU BESTELLEN, BEI DER
ARTIKELBEZEICHNUNG "LC" HINZUFUEGEN.
BEISPIEL: MNL0464010 WIRD DANN MNL0464010LC

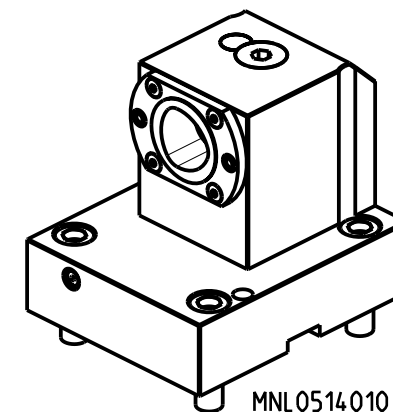

MNL0514010

Cod. MT	N°Utensili N°Tools N°Werkzeuge	Lubrificazione int. Coolant through Innenkuehlung	Reversibile lato mandrino/contromandrino Reversible sub/main spindle side Umkehrbare Spindel-seite/ Gegenspindel-seite	TAGLIA Size Masse	L1	L2	L3
MNL0514010	1	X	X	C4	114	21	68
MNL0515010	1	X	X	C5	122	31	83

DMG-MORI

NL1500/2000/2500/3000 12 STAZIONI - NLX1500/2000/2500/3000 12 STAZIONI - NLX4000 - NZL2000/2500 - NZX2500 (BMT60)
NT4200/4250/4300/5400 - NTX2000/2500/3000 2ND GEN. 10ST. - CTX2500 (BMT60)

PORTAUTENSILE ASSIALE SINGOLO ARRETRATO MT CAPTO

Axial rear-set boring single static tool MT CAPTO

Axial Single-Werkzeughalter zurueckversetzt MT CAPTO

Subject to change without notice.

M.T. srl

Via Casino Albini 480
Tel. 0541/956034-957884
Fax 0541/956341
47842 S. GIOVANNI IN M. (RN)
e-mail: mtma@mtmarchetti.com
http://www.mtmarchetti.com



PAGINA MNL555-A-40

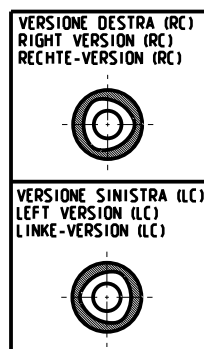
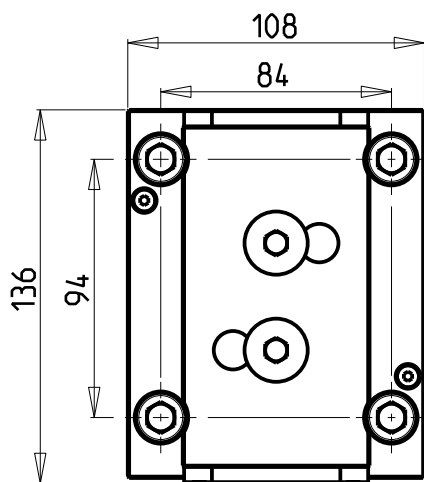
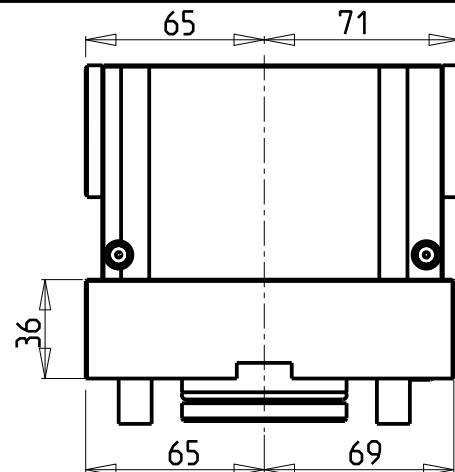
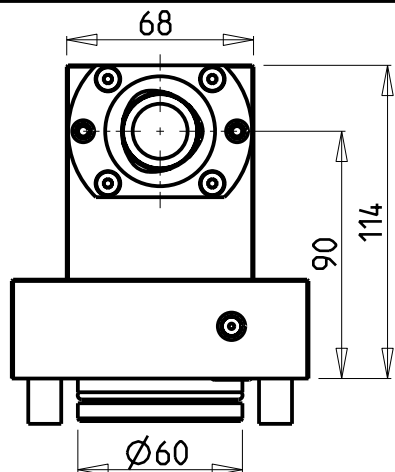

PER ORDINARE LA VERSIONE SX
AGGIUNGERE "LC" AL CODICE IN TABELLA.
ES: MNL0464010 DIVENTA MNL0464010LC

TO ORDER LEFT VERSION
ADD A "LC" IN THE CODE-CHARTS.
EXAMPLE: MNL0464010 BECOMES MNL0464010LC

UM DIE LINKE-VERSION ZU BESTELLEN, BEI DER
ARTIKELBEZEICHNUNG "LC" HINZUFUEGEN.
BEISPIEL: MNL0464010 WIRD DANN MNL0464010LC

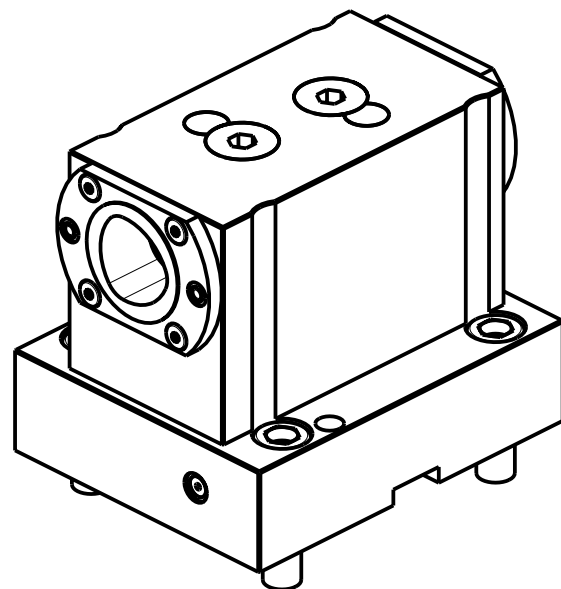

Cod. MT	N°Utensili N°Tools N°Werkzeuge	Lubrificazione int. Coolant through Innenkuehlung	Reversibile lato mandrino/contromandrino Reversible sub/main spindle side Umkehrbare Spindel-seite/ Gegenspindel-seite	TAGLIA Size Masse
MNL0504020	1+1	X	X	C4

DMG-MORI

NL1500/2000/2500/3000 12 STAZIONI - NLX1500/2000/2500/3000 12 STAZIONI - NLX4000 - NZL2000/2500 - NZX2500 (BMT60)
NT4200/4250/4300/5400 - CTX2500 (BMT60)

PORTAUTENSILE ASSIALE BISPORGENTE MT CAPTO

Axial opposite face twin static tool MT CAPTO

Axial Halter halb vorspringend mit MT CAPTO

Subject to change without notice.

M.T. srl

Via Casino Albini 480
Tel. 0541/956034-957884
Fax 0541/956341

47842 S. GIOVANNI IN M. (RN)
e-mail: mtma@mtmarchetti.com
http://www.mtmarchetti.com

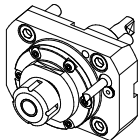
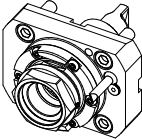
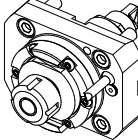
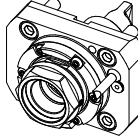
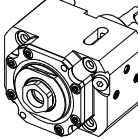
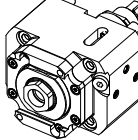
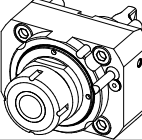
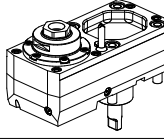
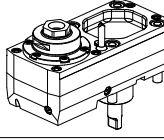
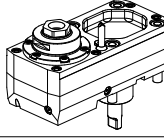
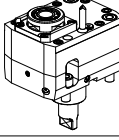
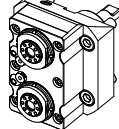

PAGINA MNL570-A-40

		PAGINA Page Seite
MODULO MOTORIZZATO RADIALE Radial driven tool Radial angetriebenes Werkzeug		MNZ010.1.00
MODULO MOTORIZZATO RADIALE MTSK Radial MTSK driven tool Radial MTSK angetriebenes Werkzeug		MNZ010.1.00.K
MODULO MOTORIZZATO RADIALE 12000 RPM Radial driven tool 12000 rpm Radial angetriebenes Werkzeug 12000 rpm		MNZ010.1.01
MODULO MOTORIZZATO RADIALE MTSK 12000 RPM Radial MTSK driven tool 12000 rpm Radial MTSK angetriebenes Werkzeug 12000 rpm		MNZ010.1.01.K
MODULO MOTORIZZATO RADIALE ALTA PRESSIONE Radial driven tool high pressure Radial angetriebenes Werkzeug hochdruck		MNZ010.1.20
MODULO MOTORIZZATO RADIALE 12000 RPM Radial driven tool 12000 rpm Radial angetriebenes Werkzeug 12000 rpm		MNZ010.1.21
MODULO MOTORIZZATO RADIALE MAGGIORATO Radial reinforced driven tool Radial angetriebenes Werkzeug vergrößert		MNZ020.1.00
MODULO MOTORIZZATO RADIALE DISASSATO IN Z 90mm Radial driven tool re-directed in Z by 90mm Radial angetriebenes Werkzeug achsversetzt in Z um 90mm		MNZ030.1.10
MODULO MOTORIZZATO RADIALE RIDOTTO I=2:1 DISASSATO IN Z 90mm Radial geared-down I=2:1 driven tool re-directed in Z by 90mm Radial angetriebenes Werkzeug untersetzt I=2:1 achsversetzt in Z um 90mm		MNZ030.1.20
MODULO MOTOR. RADIALE MOLTIPLICATO I=1:2 DISASSATO IN Z 90mm Radial geared-up I=1:2 driven tool re-directed in Z by 90mm Radial angetriebenes Werkzeug uebersetzt I=1:2 achsversetzt in Z um 90mm		MNZ030.1.30
MODULO MOTORIZZATO RADIALE DISASSATO IN Z 36mm 12000 RPM Radial driven tool re-directed in Z by 36mm 12000 rpm Radial angetriebenes Werkzeug achsversetzt in Z um 36mm 12000 rpm		MNZ033.1.11
MODULO MOTORIZZATO RADIALE 2 USCITE IN Y Radial single side twin head driven tool in Y Radial angetriebenes Werkzeug 2 Ausgaenge ueberlagert in Y		MNZ080.1.00

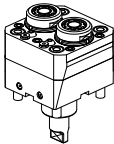
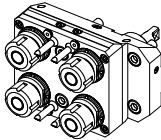
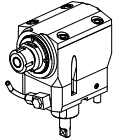
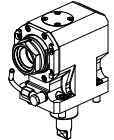
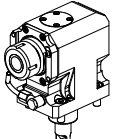
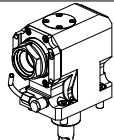
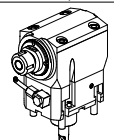
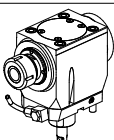
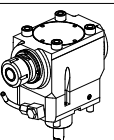
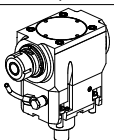
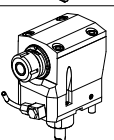
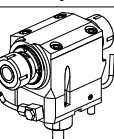
		PAGINA Page Seite
<p>MODULO MOTORIZZATO RADIALE 2 USCITE IN Y Radial single side twin head driven tool in Y Radial angetriebenes Werkzeug 2 Ausgaenge uebertlagert in Y</p>		MNZ080.1.05
<p>MODULO MOTORIZZATO RADIALE 4 USCITE Radial 4 head driven tool Radial angetriebenes Werkzeug 4 Ausgaenge</p>		MNZ100.1.00
<p>MODULO MOTORIZZATO ASSIALE H=85mm Axial driven tool H=85mm Axial angetriebenes Werkzeug H=85mm</p>		MNZ150.1.10
<p>MODULO MOTORIZZATO ASSIALE MTSK H=85mm Axial MTSK driven tool H=85mm Axial MTSK angetriebenes Werkzeug H=85mm</p>		MNZ150.1.10.K
<p>MODULO MOTORIZZATO ASSIALE 12000 RPM H=85mm Axial driven tool 12000 rpm H=85mm Axial angetriebenes Werkzeug 12000 rpm H=85mm</p>		MNZ150.1.11
<p>MODULO MOTORIZZATO ASSIALE MTSK 12000 RPM H=85mm Axial MTSK driven tool 12000 rpm H=85mm Axial MTSK angetriebenes Werkzeug 12000 rpm H=85mm</p>		MNZ150.1.11.K
<p>MODULO MOTORIZZATO ASSIALE H=100mm Axial driven tool H=100mm Axial angetriebenes Werkzeug H=100mm</p>		MNZ150.1.20
<p>MODULO MOTORIZZATO ASSIALE RIDOTTO I=2:1 Axial geared-down I=2:1 driven tool Axial angetriebenes Werkzeug untersetzt I=2:1</p>		MNZ190.1.10
<p>MODULO MOTORIZZATO ASSIALE MOLTIPLICATO I=1:2 H=85mm Axial geared-up I=1:2 driven tool H=85mm Axial angetriebenes Werkzeug uebersetzt I=1:2 H=85mm</p>		MNZ200.1.10
<p>MODULO MOTORIZZATO ASSIALE MOLTIPLICATO I=1:2 H=100mm Axial geared-up I=1:2 driven tool H=100mm Axial angetriebenes Werkzeug uebersetzt I=1:2 H=100mm</p>		MNZ200.1.20
<p>MODULO MOTOR. ASSIALE PER POLIGONATURA INTERNA H=85mm Axial driven tool for internal polygon-making H=85mm Axial angetriebenes Werkzeug fuer interne Facettierung H=85mm</p>		MNZ230.1.10
<p>MODULO MOTORIZZATO ASSIALE BISPORGENTE H=85mm Axial opposite face twin driven tool H=85mm Axial angetriebenes Werkzeug halb vorspringend H=85mm</p>		MNZ240.1.10

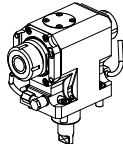
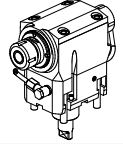
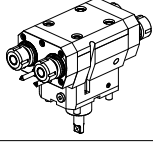
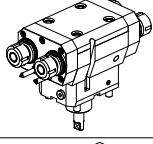
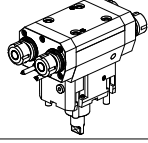
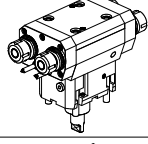
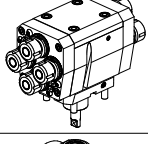
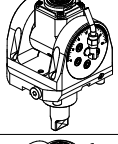
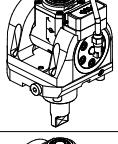
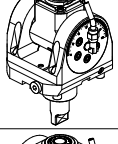
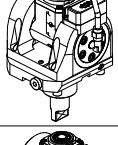
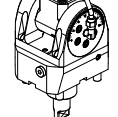
		PAGINA Page Seite
<p>MODULO MOTORIZZATO ASSIALE BISPORGENTE 12000 RPM Axial opposite face twin driven tool 12000 rpm Axial angetriebenes Werkzeug halb vorspringend 12000 rpm</p>		MNZ240.1.11
<p>MODULO MOTORIZZATO ASSIALE BISPORGENTE H=100mm Axial opposite face twin driven tool H=100mm Axial angetriebenes Werkzeug halb vorspringend H=100mm</p>		MNZ240.1.20
<p>MODULO MOTORIZZATO ASSIALE 2/4 USCITE IN Y H=85mm Axial multiple 2/4 outlet driven tool in Y H=85mm Axial angetriebenes Mehrspindel-Werkzeug 2/4 Ausgaenge in Y H=85mm</p>		MNZ268.1.00
<p>MODULO MOTORIZZATO ASSIALE 2/4 USCITE IN Y 12000 RPM H=85mm Axial multiple 2/4 outlet driven tool in Y 12000 rpm H=85mm Axial angetriebenes Mehrspindel-Werkzeug 2/4 Ausgaenge in Y 12000 rpm H=85mm</p>		MNZ268.1.01
<p>MODULO MOTORIZZATO ASSIALE 2/4 USCITE IN Y H=100mm Axial multiple 2/4 outlet driven tool in Y H=100mm Axial angetriebenes Mehrspindel-Werkzeug 2/4 Ausgaenge in Y H=100mm</p>		MNZ268.1.10
<p>MODULO MOTORIZZATO ASSIALE 2/4 USCITE IN Y 12000 RPM H=100mm Axial multiple 2/4 outlet driven tool in Y 12000 rpm H=100mm Axial angetriebenes Mehrspindel-Werkzeug 2/4 Ausgaenge in Y 12000 rpm H=100mm</p>		MNZ268.1.11
<p>MODULO MOTORIZZATO ASSIALE 4/8 USCITE Axial multiple 4/8 outlet driven tool Axial angetriebenes Mehrspindel-Werkzeug 4/8 Ausgaenge</p>		MNZ270.1.00
<p>MODULO MOTORIZZATO ORIENTABILE +/-90° H=50mm +/-90° adjustable angle driven tool H=50mm Angetriebenes Werkzeug schwenkbar +/-90° H=50mm</p>		MNZ335.1.00
<p>MODULO MOTORIZZATO ORIENTABILE +/-90° CON NONIO DIGITALE H=50mm +/-90° adjustable angle driven tool with digital display H=50mm Angetriebenes Werkzeug schwenkbar +/-90° mit digital display H=50mm</p>		MNZ335.1.01
<p>MODULO MOTORIZZATO ORIENTABILE +/-90° 12000 RPM H=50mm +/-90° adjustable angle driven tool 12000 rpm H=50mm Angetriebenes Werkzeug schwenkbar +/-90° 12000 rpm H=50mm</p>		MNZ335.1.02
<p>MODULO MOTOR. ORIENT. +/-90° 12000 RPM CON NONIO DIGIT. H=50mm +/-90° adjustable angle driven tool 12000 rpm with digital display H=50mm Angetriebenes Werkzeug schwenkbar +/-90° 12000 rpm mit digital display H=50mm</p>		MNZ335.1.03
<p>MODULO MOTORIZZATO ORIENTABILE +/-90° H=77mm +/-90° adjustable angle driven tool H=77mm Angetriebenes Werkzeug schwenkbar +/-90° H=77mm</p>		MNZ335.1.10

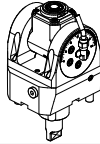
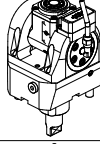
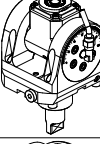
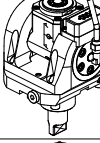
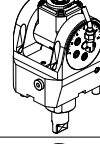
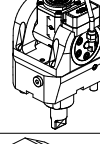
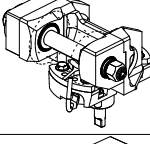
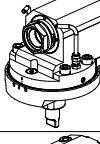
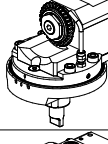
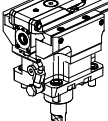
		PAGINA Page Seite
<p>MODULO MOTORIZZ. ORIENTABILE +/-90° CON NONIO DIGITALE H=77mm +/-90° adjustable angle driven tool with digital display H=77mm Angetriebenes Werkzeug schwenkbar +/-90° mit digital display H=77mm</p>		MNZ335.1.11
<p>MODULO MOTORIZZATO ORIENTABILE +/-90° 12000 RPM H=77mm +/-90° adjustable angle driven tool 12000 rpm H=77mm Angetriebenes Werkzeug schwenkbar +/-90° 12000 rpm H=77mm</p>		MNZ335.1.12
<p>MODULO MOTOR. ORIENT. +/-90° 12000 RPM CON NONIO DIGIT. H=77mm +/-90° adjustable angle driven tool 12000 rpm with digital display H=77mm Angetriebenes Werkzeug schwenkbar +/-90° 12000 rpm mit digital display H=77mm</p>		MNZ335.1.13
<p>MODULO MOTORIZZATO ORIENTABILE +/-90° MOLTIPLICATO l=1:2 H=50mm +/-90° adjustable angle driven tool geared-up l=1:2 H=50mm Angetriebenes Werkzeug schwenkbar +/-90° uebersetzt l=1:2 H=50mm</p>		MNZ336.1.00
<p>MODULO MOT. ORIENT. +/-90° MOLTIPL. l=1:2 CON NONIO DIGIT. H=50mm +/-90° adjustable angle driven tool geared-up l=1:2 with digital display H=50mm Angetr. Werkzeug schwenkbar +/-90° uebersetzt l=1:2 mit digital display H=50mm</p>		MNZ336.1.01
<p>MODULO MOTORIZZATO ORIENTABILE +/-90° MOLTIPLICATO l=1:2 H=77mm +/-90° adjustable angle driven tool geared-up l=1:2 H=77mm Angetriebenes Werkzeug schwenkbar +/-90° uebersetzt l=1:2 H=77mm</p>		MNZ336.1.10
<p>MODULO MOT. ORIENT. +/-90° MOLTIPL. l=1:2 CON NONIO DIGIT. H=77mm +/-90° adjustable angle driven tool geared-up l=1:2 with digital display H=77mm Angetr. Werkzeug schwenkbar +/-90° uebersetzt l=1:2 mit digital display H=77mm</p>		MNZ336.1.11
<p>MODULO MOTORIZZATO PORTACREATORE Driven gear hobber Angetriebenes Zahnradwaelzfraes-Werkzeug</p>		MNZ340.1.00
<p>MODULO MOTORIZZATO ASSIALE MTSK PER POWER SKIVING H=98,5mm Axial MTSK driven tool for Power Skiving H=98,5mm Axial MTSK angetriebenes Werkzeug fuer Power Skiving H=98,5mm</p>		MNZ350.1.00.K
<p>MODULO MOTORIZZATO ASSIALE ANGOLARE ±180° Axial adjustable angle ±180° driven tool Axial angetriebenes Werkzeug schwenkbar ±180°</p>		MNZ355.1.00
<p>MODULO MOTORIZZATO PER VITI SENZA FINE Driven tool for worm screws Angetriebenes werkzeug fuer schrauben ohne ende</p>		MNZ359.1.00
<p>MODULO MOTORIZZATO STOZZATORE CORSA 50mm H=85mm Slotting driven tool 50mm stroke H=85mm Keilnutenstossmaschine 50mm Hub H=85mm</p>		MNZ360.1.00

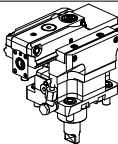
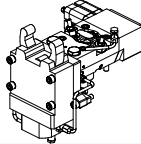
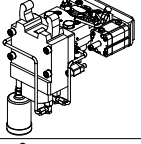
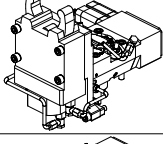
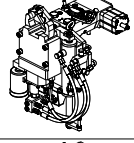
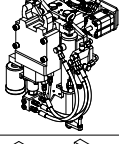
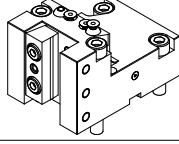
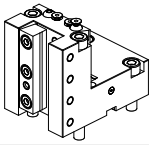
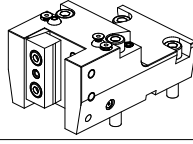
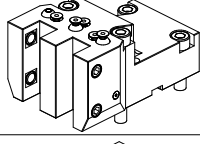
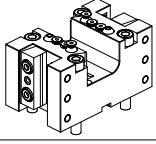
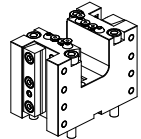
		PAGINA Page Seite
<p>MODULO MOTORIZZATO STOZZATORE CORSA 25mm H=85mm Slotting driven tool 25mm stroke H=85mm Keilnutenstossmaschine 25mm Hub H=85mm</p>		MNZ360.1.01
<p>MODULO MOTORIZZATO PER LUNETTA (TAGLIA 1) Steady rest driven tool (Size 1) Angetriebenes werkzeug fuer luenette (Groesse 1)</p>		MNZ361.1.00
<p>MODULO MOTORIZZATO PER LUNETTA (TAGLIA 1) Steady rest driven tool (Size 1) Angetriebenes werkzeug fuer luenette (Groesse 1)</p>		MNZ361.1.10
<p>MODULO MOTORIZZATO PER LUNETTA RIALZATA (TAGLIA 1) Higher version steady rest driven tool (Size 1) Angetriebenes werkzeug fuer luenette, hoehere Version (Groesse 1)</p>		MNZ362.1.00
<p>MODULO MOTORIZZATO PER LUNETTA RETRATTILE (TAGLIA 1) Driven toolholder for sliding steady rest (Size 1) Luenettenwerkzeug zurueck versetzte Version (Groesse 1)</p>		MNZ363.1.00
<p>MODULO MOTORIZZATO PER LUNETTA RETRATTILE (TAGLIA 1) Driven toolholder for sliding steady rest (Size 1) Luenettenwerkzeug zurueck versetzte Version (Groesse 1)</p>		MNZ363.1.10
<p>PORTAUTENSILE RADIALE SINGOLO QD=20mm / QD=3/4" H=70mm Radial single static tool QD=20mm / QD=3/4" H=70mm Radial Single-Werkzeughalter QD=20mm / QD=3/4" H=70mm</p>		MNZ420.1.00
<p>PORTAUTENSILE RADIALE SINGOLO QD=20mm / QD=3/4" H=95mm Radial single static tool QD=20mm / QD=3/4" H=95mm Radial Single-Werkzeughalter QD=20mm / QD=3/4" H=95mm</p>		MNZ420.1.10
<p>PORTAUTENSILE RADIALE SINGOLO QD=25mm / QD=1" H=70mm Radial single static tool QD=25mm / QD=1" H=70mm Radial Single-Werkzeughalter QD=25mm / QD=1" H=70mm</p>		MNZ423.1.00
<p>PORTAUTENSILE RADIALE SOVRAPPOSTO QD=20mm / QD=3/4" H=70mm Radial single side twin static tool QD=20mm / QD=3/4" H=70mm Radial Werkzeughalter ueberlagert QD=20mm / QD=3/4" H=70mm</p>		MNZ440.1.00
<p>PORTAUTENSILE RADIALE DOPPIO QD=20mm / QD=3/4" H=70mm Radial double static tool QD=20mm / QD=3/4" H=70mm Radial Doppel-Werkzeughalter QD=20mm / QD=3/4" H=70mm</p>		MNZ450.1.00
<p>PORTAUTENSILE RADIALE DOPPIO QD=20mm / QD=3/4" H=95mm Radial double static tool QD=20mm / QD=3/4" H=95mm Radial Doppel-Werkzeughalter QD=20mm / QD=3/4" H=95mm</p>		MNZ450.1.10

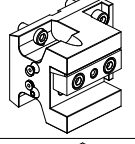
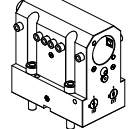
		PAGINA Page Seite
<p>PORTAUT. RADIALE DOPPIO SOVRAPPOSTO QD=20mm / QD=3/4" H=70mm Radial double side twin static tool QD=20mm / QD=3/4" H=70mm Radial Doppel-Werkzeughalter ueberlagert QD=20mm / QD=3/4" H=70mm</p>		MNZ460.1.00
<p>PORTAUTENSILE PER LAMA DOPPIO Radial double blade holder Radial Doppel-Abstechhalter</p>		MNZ520.1.00
<p>PORTAUTENSILE RADIALE PER LAMA Radial blade holder Radial Abstechhalter</p>		MNZ520.1.01
<p>PORTAUTENSILE PER LAMA DOPPIO CON LUBRIFICAZIONE INTERNA Radial double blade holder with internal coolant Radial Doppel-Abstechhalter mit Innenkuehlung</p>		MNZ520.1.04
<p>PORTAUTENSILE RADIALE PER LAMA CON LUBRIFICAZIONE INTERNA Radial blade holder with internal coolant Radial Abstechhalter mit Innenkuehlung</p>		MNZ520.1.05
<p>PORTAUTENSILE ASSIALE SINGOLO QD=20mm / QD=3/4" H=85mm Axial single static tool QD=20mm / QD=3/4" H=85mm Axial Single-Werkzeughalter QD=20mm / QD=3/4" H=85mm</p>		MNZ550.1.00
<p>PORTAUTENSILE ASSIALE SINGOLO QD=20mm / QD=3/4" H=50mm Axial single static tool QD=20mm / QD=3/4" H=50mm Axial Single-Werkzeughalter QD=20mm / QD=3/4" H=50mm</p>		MNZ550.1.10
<p>PORTAUTENSILE ASSIALE SINGOLO QD=25mm Axial single static tool QD=25mm Axial Single-Werkzeughalter QD=25mm</p>		MNZ552.1.00
<p>PORTAUTENSILE ASSIALE DOPPIO QD=20mm / QD=3/4" Axial double static tool QD=20mm / QD=3/4" Axial Doppel-Werkzeughalter QD=20mm / QD=3/4"</p>		MNZ570.1.00
<p>PORTAUTENSILE ASSIALE DOPPIO QD=25mm / QD=1" Axial double static tool QD=25mm / QD=1" Axial Doppel-Werkzeughalter QD=25mm / QD=1"</p>		MNZ572.1.00
<p>PORTAUTENSILE ASSIALE PER BARENO Ø40mm / Ø1 1/2" H=90mm Axial single boring bar holder Ø40mm / Ø1 1/2" H=90mm Axial Bohrhalter Ø40mm / Ø1 1/2" H=90mm</p>		MNZ630.1.20
<p>PORTAUTENSILE ASSIALE PER BARENO Ø40mm H=100mm Axial single boring bar holder Ø40mm H=100mm Axial Bohrhalter Ø40mm H=100mm</p>		MNZ640.1.10

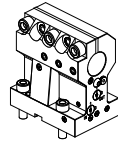
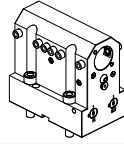
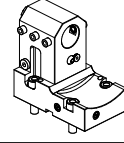
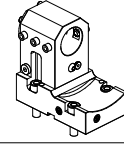
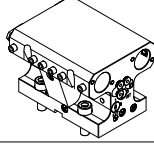
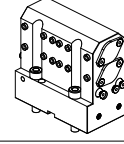
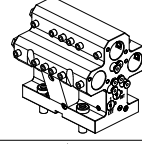
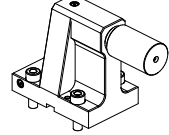
		PAGINA Page Seite
<p>PORTAUTENSILE ASSIALE PER BARENO $\varnothing 32\text{mm}$ / $\varnothing 1\frac{1}{4}"$ H=90mm Axial single boring bar holder $\varnothing 32\text{mm}$ / $\varnothing 1\frac{1}{4}"$ H=90mm Axial Bohrhalter $\varnothing 32\text{mm}$ / $\varnothing 1\frac{1}{4}"$ H=90mm</p>		MNZ650.1.20
<p>PORTAUTENSILE ASSIALE PER BARENO $\varnothing 32\text{mm}$ / $\varnothing 1\frac{1}{4}"$ H=100mm Axial single boring bar holder $\varnothing 32\text{mm}$ / $\varnothing 1\frac{1}{4}"$ H=100mm Axial Bohrhalter $\varnothing 32\text{mm}$ / $\varnothing 1\frac{1}{4}"$ H=100mm</p>		MNZ660.1.10
<p>PORTAUTENSILE ASSIALE ARRETRATO PER BARENO $\varnothing 32\text{mm}$ H=100mm Axial single rear set boring bar holder $\varnothing 32\text{mm}$ H=100mm Axial Bohrhalter zurueckversetzt $\varnothing 32$ mm H=100mm</p>		MNZ845.1.10
<p>PORTAUTENSILE ASSIALE ARRETRATO PER BARENO $\varnothing 40\text{mm}$ H=100mm Axial single rear set boring bar holder $\varnothing 40\text{mm}$ H=100mm Axial Bohrhalter zurueckversetzt $\varnothing 40\text{mm}$ H=100mm</p>		MNZ845.1.20
<p>PORTAUT. ASSIALE PER BARENO 2+2 POSIZIONI $\varnothing 25\text{mm}$ / $\varnothing 1"$ / $\varnothing 20\text{mm}$ / $\varnothing 3/4"$ Axial 2+2 position boring bar holder $\varnothing 25\text{mm}$ / $\varnothing 1"$ / $\varnothing 20\text{mm}$ / $\varnothing 3/4"$ Axial Bohrhalter 2+2 Positionen $\varnothing 25\text{mm}$ / $\varnothing 1"$ / $\varnothing 20\text{mm}$ / $\varnothing 3/4"$</p>		MNZ864.1.00
<p>PORTAUT. ASSIALE PER BARENO 2+2 POSIZIONI $\varnothing 25\text{mm}$ / $\varnothing 1"$ Axial 2+2 position boring bar holder $\varnothing 25\text{mm}$ / $\varnothing 1"$ Axial Bohrhalter 2+2 Positionen $\varnothing 25\text{mm}$ / $\varnothing 1"$</p>		MNZ874.1.00
<p>PORTAUT. ASSIALE PER BARENO 3+3 POSIZIONI $\varnothing 25\text{mm}$ / $\varnothing 1"$ / $\varnothing 20\text{mm}$ / $\varnothing 3/4"$ Axial 3+3 position boring bar holder $\varnothing 25\text{mm}$ / $\varnothing 1"$ / $\varnothing 20\text{mm}$ / $\varnothing 3/4"$ Axial Bohrhalter 3+3 Positionen $\varnothing 25\text{mm}$ / $\varnothing 1"$ / $\varnothing 20\text{mm}$ / $\varnothing 3/4"$</p>		MNZ914.1.00
<p>CONTROPUNTA PER CONTROMANDRINO Tailstock for subspindle Gegenspintz fuer Gegenspindel</p>		MNZ950.1.00

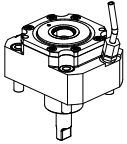
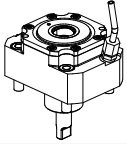
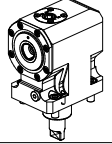
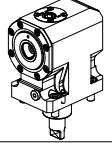
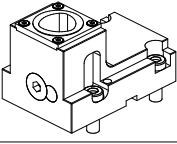
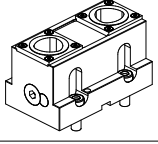
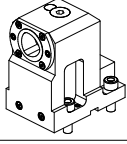
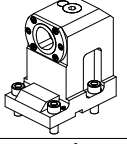
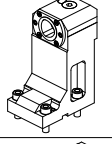
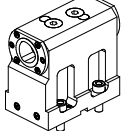
		PAGINA Page Seite
<p>MODULO MOTORIZZATO RADIALE MT CAPTO Radial driven tool MT CAPTO Radial angetriebenes Werkzeug MT CAPTO</p>		MNZ010.A.30
<p>MODULO MOTORIZZATO RADIALE 12000 RPM MT CAPTO Radial driven tool 12000 rpm MT CAPTO Radial angetriebenes Werkzeug 12000 rpm MT CAPTO</p>		MNZ010.A.31
<p>MODULO MOTORIZZATO ASSIALE MT CAPTO Axial driven tool MT CAPTO Axial angetriebenes Werkzeug MT CAPTO</p>		MNZ150.A.30
<p>MODULO MOTORIZZATO ASSIALE 12000 RPM MT CAPTO Axial driven tool 12000 rpm MT CAPTO Axial angetriebenes Werkzeug 12000 rpm MT CAPTO</p>		MNZ150.A.31
<p>PORTAUTENSILE RADIALE SINGOLO MT CAPTO Radial single static tool MT CAPTO Radial Single-Werkzeughalter MT CAPTO</p>		MNZ420.A.40
<p>PORTAUTENSILE RADIALE DOPPIO MT CAPTO Radial double static tool MT CAPTO Radial doppel-Werkzeughalter MT CAPTO</p>		MNZ450.A.40
<p>PORTAUTENSILE ASSIALE SINGOLO MT CAPTO Axial single static tool MT CAPTO Axial Single-Werkzeughalter MT CAPTO</p>		MNZ550.A.40
<p>PORTAUTENSILE ASSIALE SINGOLO ARRETRATO MT CAPTO Axial single rear-set boring static tool MT CAPTO Axial Single-Werkzeughalter zurueckversetzt MT CAPTO</p>		MNZ555.A.40
<p>PORTAUTENSILE ASSIALE SINGOLO ARRETRATO MT CAPTO Axial single rear-set boring static tool MT CAPTO Axial Single-Werkzeughalter zurueckversetzt MT CAPTO</p>		MNZ556.A.40
<p>PORTAUTENSILE ASSIALE BISPORGENTE MT CAPTO Axial opposite face twin static tool MT CAPTO Axial Halter halb vorspringend mit MT CAPTO</p>		MNZ570.A.40

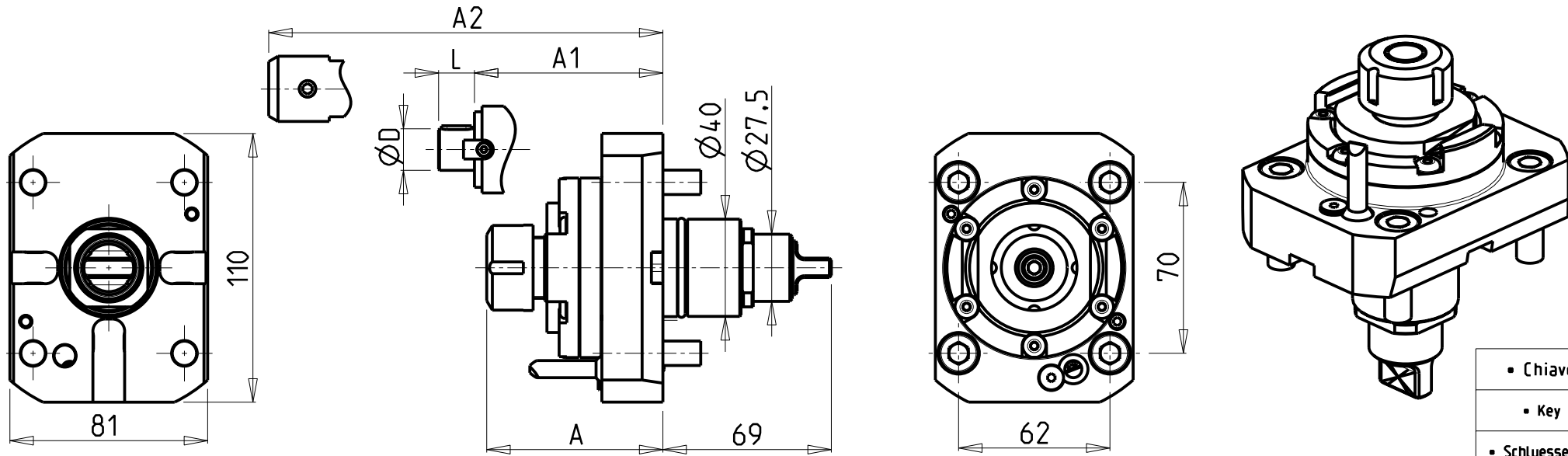

- Chiave inclusa
- Key included
- Schluessel inbegriffen

Cod. MT	Cod. MORI-SEIKI	Mandrino Spindel Spindel	I	RPM	Coppia Max Max Torque Max Drehmoment	Lubrificazione int. Coolant through Innenkuehlung	Lubrificazione est. Ext. coolant Aussenkuehlung	A	A1	A2	D	L	CHIAVI NON INCLUDE Keys not included Schluessel nicht einbegriffen	
MNZ0020120	T32254	ER20	1:1	6000	40Nm		X	72.16	-	-	-	-	MNZ0410005	CHSTER20
MNZ0020125	T32274	ER25	1:1	6000	40Nm		X	73.16	-	-	-	-	MNZ0410005	CHSTER25
MNZ0020132	-	ER32	1:1	6000	40Nm		X	76.16	-	-	-	-	MNZ0410005	CHSTER32
MNZ0020225	-	ER25	1:1	6000	40Nm	P=30bar	X	81.66	-	-	-	-	MNZ0410005	CHSTER25
MNZ0020232	-	ER32	1:1	6000	40Nm	P=30bar	X	86.16	-	-	-	-	MNZ0410005	CHSTER32
MNZ0020416	-	Ø16x17	1:1	6000	40Nm		X	-	54.5	-	16	17	MNZ0410005	CH_VTCROCE_M08
MNZ0020422	-	Ø22x19	1:1	6000	40Nm		X	-	54.5	-	22	19	MNZ0410005	CH_VTCROCE_M10
MNZ0020419	-	Ø3/4"x3/4"	1:1	6000	40Nm		X	-	54.5	-	3/4"	3/4"	MNZ0410005	CH_VTCROCE_M08
MNZ0020308	-	WELDON 8	1:1	6000	40Nm		X	-	-	72.5	-	-		
MNZ0020310	-	WELDON 10	1:1	6000	40Nm		X	-	-	74.5	-	-		
MNZ0020312	-	WELDON 12	1:1	6000	40Nm		X	-	-	77	-	-		
MNZ0020316	-	WELDON 16	1:1	6000	40Nm		X	-	-	79.5	-	-		

DMG-MORI

NZ1500/2000 - NZX1500/2000 - NZX2500 (BMT40) - NT3100/3150/3200 - NL1500/2000/2500 20 STAZ. - NLX1500/2000/2500 20 STAZ. - NT1000/2000
 NTX1000/2000 - NTX1000/2000/2500/3000 2ND GEN. 12ST. - DURATURN 2050MC/2550MC - NRX2000 - ALX1500/2000/2500 - ECOTURN 450 (BMT40)

MODULO MOTORIZZATO RADIALE
 Radial driven tool
 Radial angetriebenes Werkzeug

Subject to change without notice.

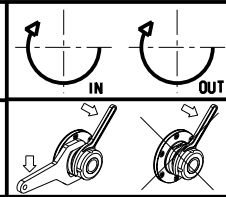

M.T. srl

Via Casino Albini 480
 Tel. 0541/956034-957884
 Fax 0541/956341
 47842 S. GIOVANNI IN M. (RN)
 e-mail: mtma@mtmarchetti.com
 http://www.mtmarchetti.com



PAGINA MNZ010-1-00

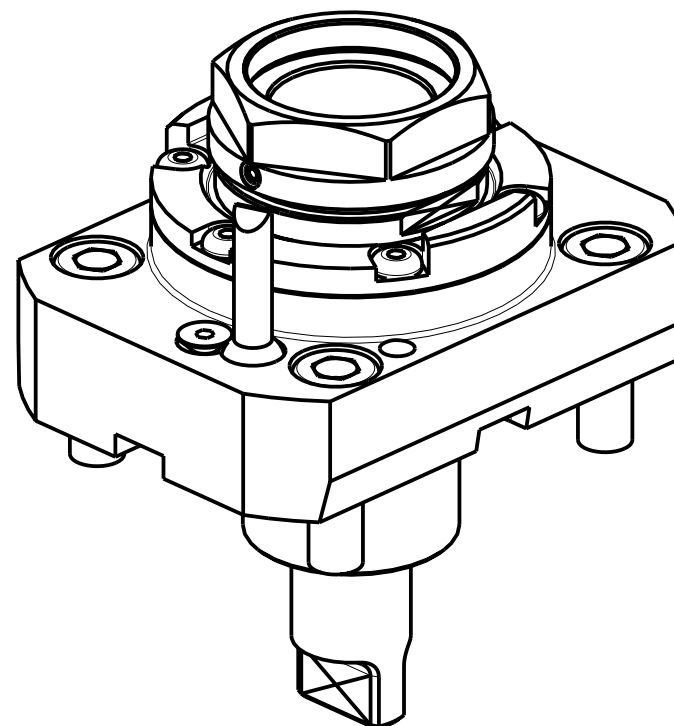
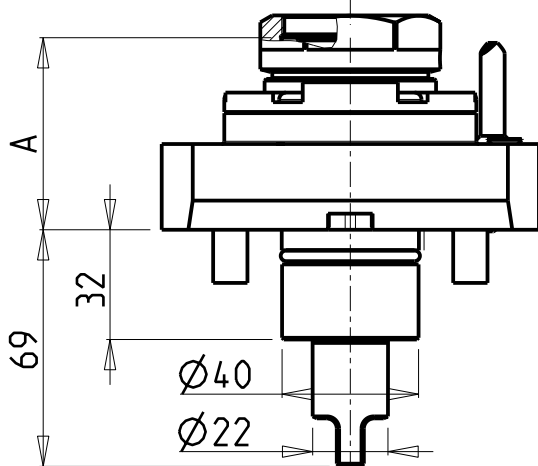
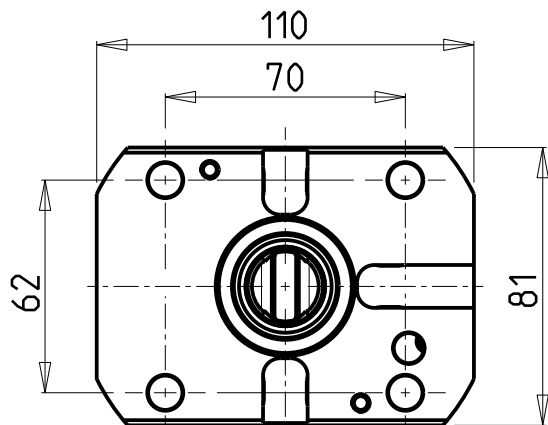

PER PORTAUTENSILI MODULARI MTSK-40 VEDI PAG. TBL300-1-40
 FOR MTSK-40 QUICK CHANGE TOOLHOLDERS CLAMPINGS SEE PAGE TBL300-1-40
 FUER MTSK-40 MODULARE WERKZEUGAUFNAHMEN SIEHE SEITE TBL300-1-40

Cod. MT	Mandrino Spindle Spindel	I	RPM	Coppia Max Max Torque Max Drehmoment	Lubrificazione int. Coolant through Innenkuehlung	Lubrificazione est. Ext. coolant Aussenkuehlung	A	CHIAVI NON INCLUSE Keys not included Schlüssel nicht einbegriffen	
MNZ0410140	MTSK-40	1:1	6000	40Nm	-	X	56	CHUB46	MNZ0410005 •
MNZ0410240	MTSK-40	1:1	6000	40Nm	P=70bar	X	68	CHUB46	MNZ0410005 •

- Chiave inclusa
- Key included
- Schlüssel inbegriffen

DMG-MORI

NZ1500/2000 - NZX1500/2000 - NZX2500 (BMT40) - NT3100/3150/3200 - NL1500/2000/2500 20 STAZ. - NLX1500/2000/2500 20 STAZ. - NT1000/2000
 NTX1000/2000 - NTX1000/2000/2500/3000 2ND GEN. 12ST. - DURATURN 2050MC/2550MC - NRX2000 - ALX1500/2000/2500 - ECOTURN 450 (BMT40)

MODULO MOTORIZZATO RADIALE MTSK

Radial MTSK driven tool

Radial MTSK angetriebenes Werkzeug

Subject to change without notice.

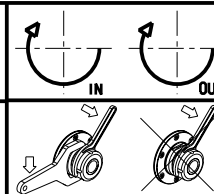

M.T. srl

Via Casino Albini 480
 Tel. 0541/956034-957884
 Fax 0541/956341

47842 S. GIOVANNI IN M. (RN)
 e-mail: mtma@tmarchetti.com
 http://www.tmmarchetti.com



PAGINA MNZ010-1-00-K

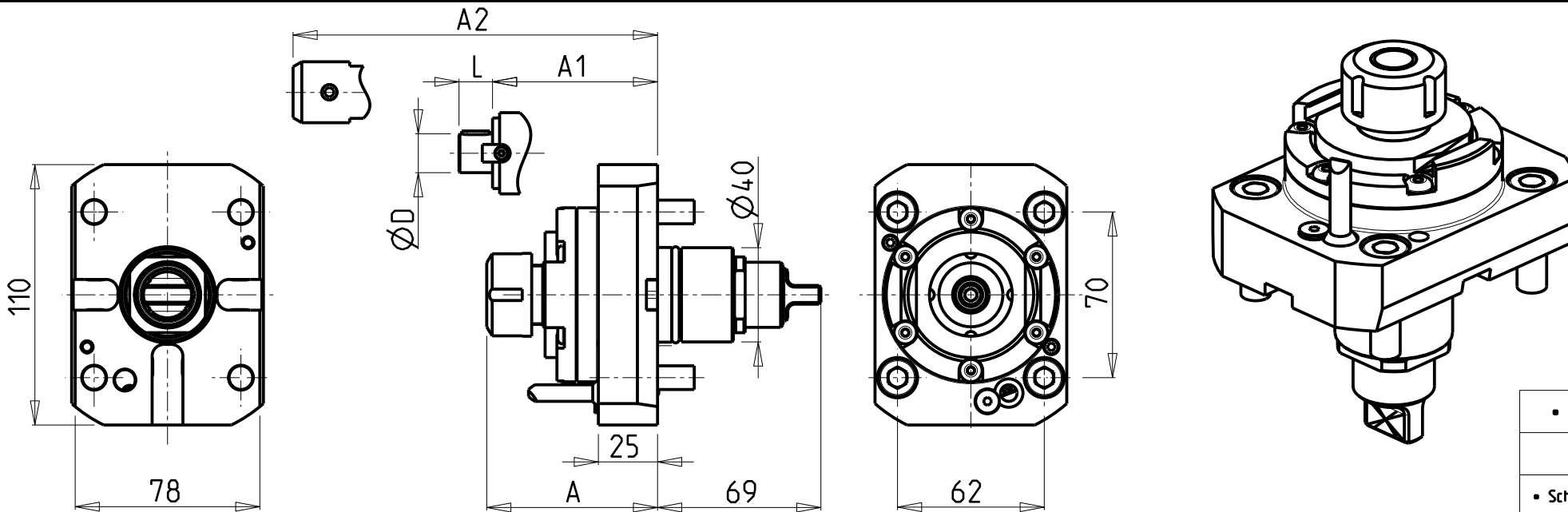

- Chiave inclusa
- Key included
- Schlüssel inbegriffen

Cod. MT	Mandrino Spindle Spindel	I	RPM	Coppia Max Max Torque Max Drehmoment	Lubrificazione int. Coolant through Innenkuehlung	Lubrificazione est. Ext. coolant Aussenkuehlung	A	A1	A2	D	L	CHIAVI NON INCLUDE Keys not included Schlüssel nicht einbegriffen	
MNZ0440120	ER20	1:1	12000	40Nm	-	X	72.16	-	-	-	-	MNZ0410005	CHSTER20
MNZ0440125	ER25	1:1	12000	40Nm	-	X	73.16	-	-	-	-	MNZ0410005	CHSTER25
MNZ0440132	ER32	1:1	12000	40Nm	-	X	76.16	-	-	-	-	MNZ0410005	CHSTER32
MNZ0440232	ER32	1:1	12000	40Nm	P=70bar	X	86.66	-	-	-	-	MNZ0410005	CHSTER32
MNZ0440416	Ø16x17	1:1	12000	40Nm	-	X	-	54.5	-	16	17	MNZ0410005	CH_VTCROCE_M08
MNZ0440422	Ø22x19	1:1	12000	40Nm	-	X	-	54.5	-	22	19	MNZ0410005	CH_VTCROCE_M10
MNZ0440419	Ø3/4"x3/4"	1:1	12000	40Nm	-	X	-	54.5	-	3/4"	3/4"	MNZ0410005	CH_VTCROCE_M08
MNZ0440308	WELDON 8	1:1	12000	40Nm	-	X	-	-	72.5	-	-	-	-
MNZ0440310	WELDON 10	1:1	12000	40Nm	-	X	-	-	74.5	-	-	-	-
MNZ0440312	WELDON 12	1:1	12000	40Nm	-	X	-	-	77	-	-	-	-
MNZ0440316	WELDON 16	1:1	12000	40Nm	-	X	-	-	79.5	-	-	-	-

NEW

DMG-MORI
 NZ1500/2000 - NZX1500/2000 - NZX2500 (BMT40) - NL1500/2000/2500 20 STAZ. - NLX1500/2000/2500 20 STAZ.
 NTX1000/2000 - NTX1000/2000/2500/3000 2ND GEN. 12ST. - NRX2000 - ALX1500/2000/2500

MODULO MOTORIZZATO RADIALE 12000 RPM
 Radial driven tool 12000 rpm
 Radial angetriebenes Werkzeug 12000 rpm

Subject to change without notice.

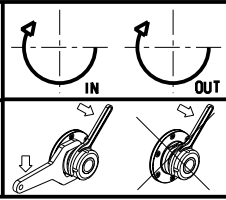

M.T. srl
 Via Casino Albini 480
 Tel. 0541/956034-957884
 Fax 0541/956341
 47842 S. GIOVANNI IN M. (RN)
 e-mail: mtma@mtmarchetti.com
 http://www.mtmarchetti.com



PAGINA MNZ010-1-01

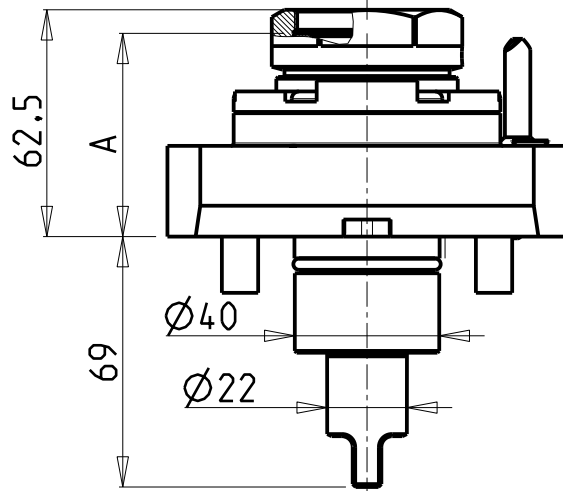
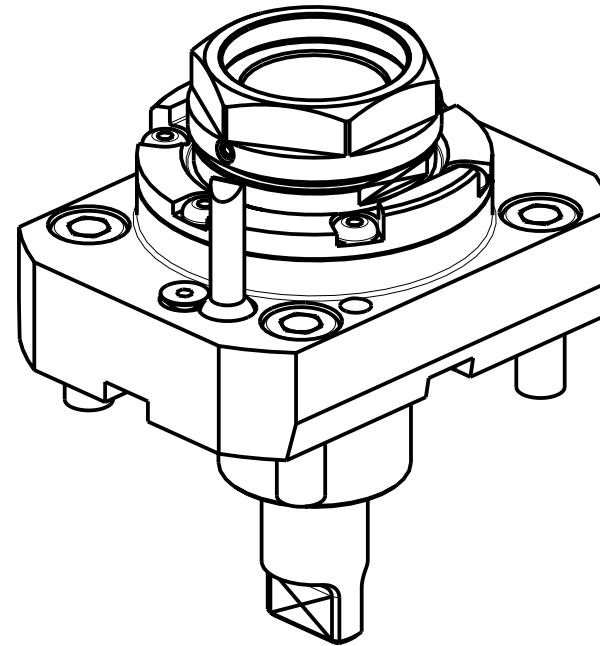
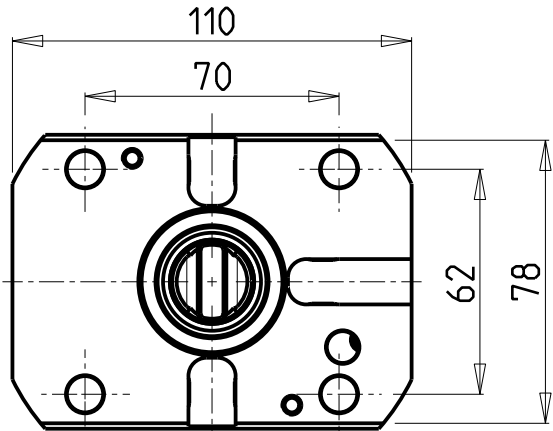

PER PORTAUTENSILI MODULARI MTSK-40 VEDI PAG. TBL300-1-40
 FOR MTSK-40 QUIK CHANGE TOOLHOLDERS CLAMPINGS SEE PAGE TBL300-1-40
 FUER MTSK-40 MODULARE WERKZEUGAUFNAHMEN SIEHE SEITE TBL300-1-40

Cod. MT	Mandrino Spindle Spindel	I	RPM	Coppia Max Max Torque Max Drehmoment	Lubrificazione int. Coolant through Innenkuehlung	Lubrificazione est. Ext. coolant Aussenkuehlung	A	CHIAVI NON INCLUSE Keys not included Schlüssel nicht einbegriffen	
MNZ0450140	MTSK-40	1:1	12000	40Nm	-	X	56	CHUB46	MNZ0410005 *
MNZ0450240	MTSK-40	1:1	12000	40Nm	P=70bar	X	68	CHUB46	MNZ0410005 *

- Chiave inclusa
- Key included
- Schlüssel inbegriffen

NEW

DMG-MORI

NZ1500/2000 - NZX1500/2000 - NZX2500 (BMT40) - NL1500/2000/2500 20 STAZ. - NLX1500/2000/2500 20 STAZ.
 NTX1000/2000 - NTX1000/2000/2500/3000 2ND GEN. 12ST. - NRX2000 - ALX1500/2000/2500

MODULO MOTORIZZATO RADIALE MTSK 12000 RPM

Radial MTSK driven tool 12000 rpm

Radial MTSK angetriebenes Werkzeug 12000 rpm

Subject to change without notice.

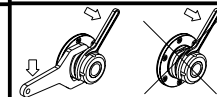
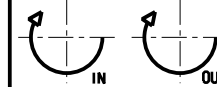

M.T. srl

Via Casino Albini 480
 Tel. 0541/956034-957884
 Fax 0541/956341
 47842 S. GIOVANNI IN M. (RN)
 e-mail: mtma@mtmarchetti.com
 http://www.mtmarchetti.com



PAGINA MNZ010-1-01-K

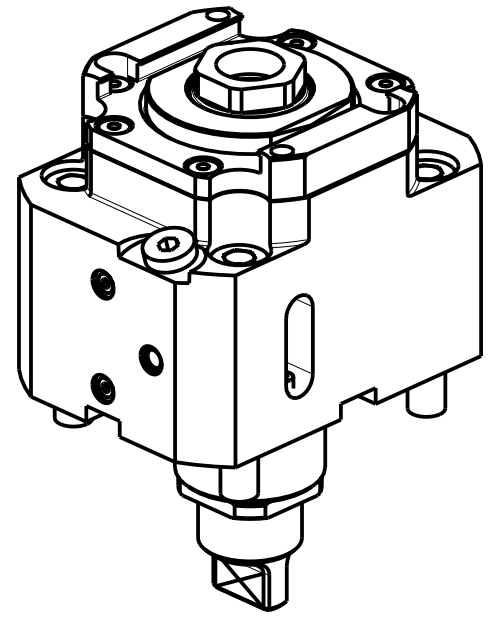
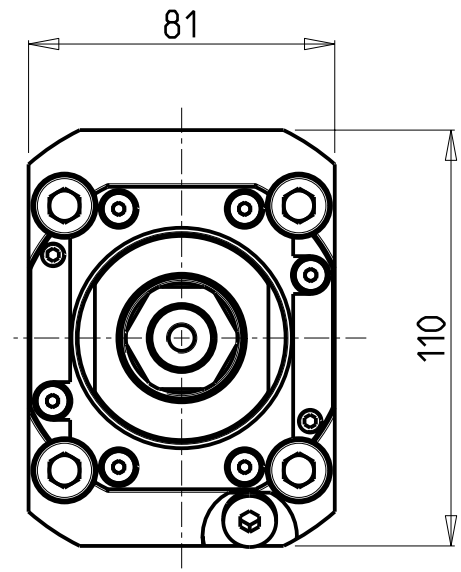
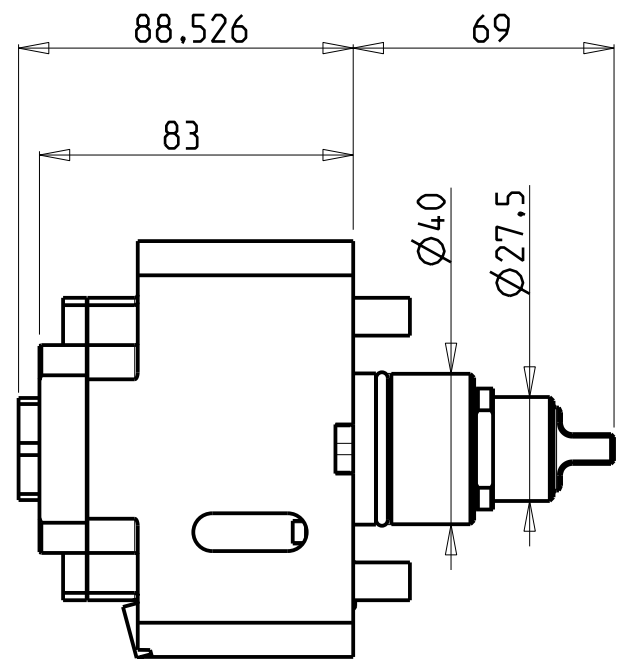
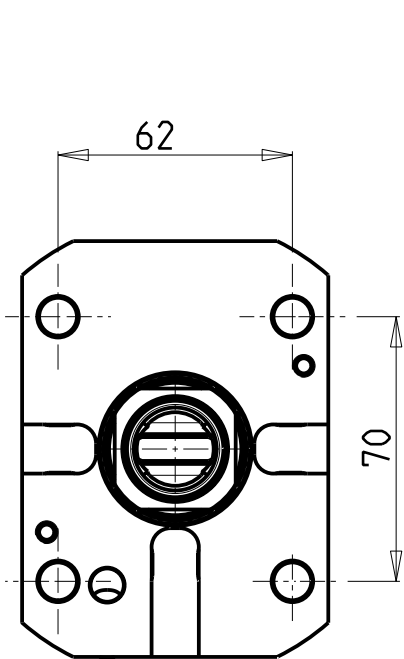

- Chiave inclusa
- Key included
- Schluessel inbegriffen

Cod. MT	Cod. MORI-SEIKI	Mandrino Spindle Spindel	I	RPM	Coppia Max Max Torque Max Drehmoment	Lubrificazione int. Coolant through Innenkuehlung	Lubrificazione est. Ext. coolant Aussenkuehlung	CHIAVI NON INCLUSE Keys not included Schluessel nicht inbegriffen	
MNZ0340125	-	ERA25	1:1	6000	40Nm	P=80bar	X	MNZ0410005 ▪	CHUB27

DMG-MORI

NZ1500/2000 - NZX1500/2000 - NZX2500 (BMT40) - NT3100/3150/3200 - NL1500/2000/2500 20 STAZ. - NLX1500/2000/2500 20 STAZ. - NT1000/2000
 NTX1000/2000 - NTX1000/2000/2500/3000 2ND GEN. 12ST. - DURATURN 2050MC/2550MC - NRX2000 - ALX1500/2000/2500 - ECOTURN 450 (BMT40)

MODULO MOTORIZZATO RADIALE ALTA PRESSIONE

Radial driven tool high pressure
 Radial angetriebenes Werkzeug hochdruck

Subject to change without notice.

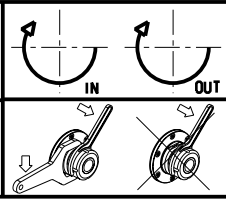

M.T. srl
 Via Casino Albini 480
 Tel. 0541/956034-957884
 Fax 0541/956341
 47842 S. GIOVANNI IN M. (RN)
 e-mail: mtma@tmarchetti.com
 http://www.tmmarchetti.com



PAGINA MNZ010-1-20

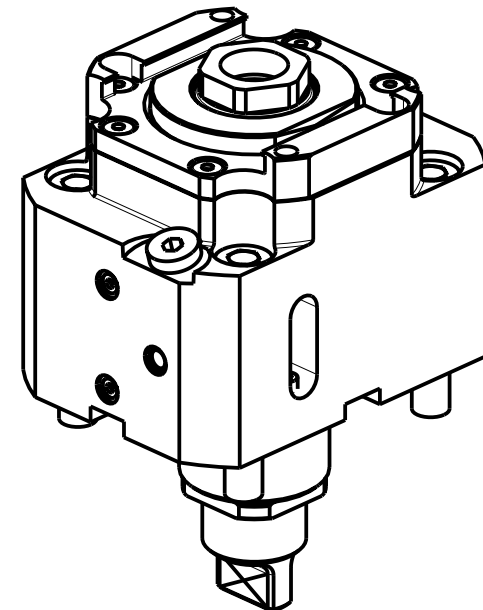
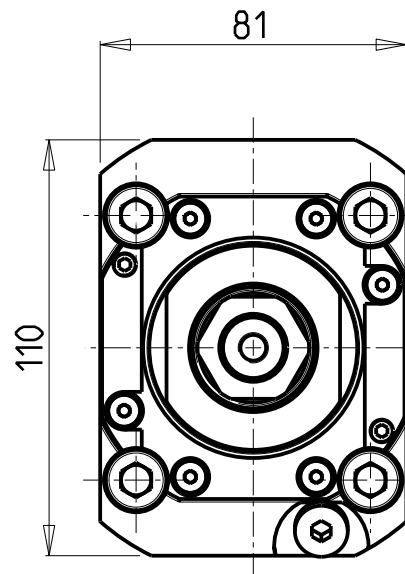
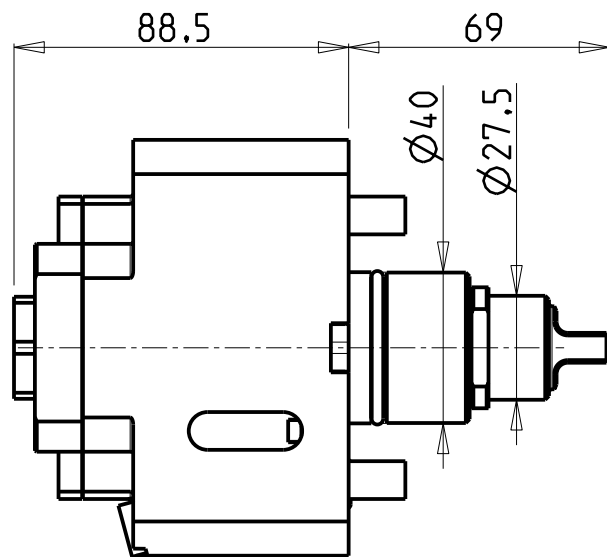
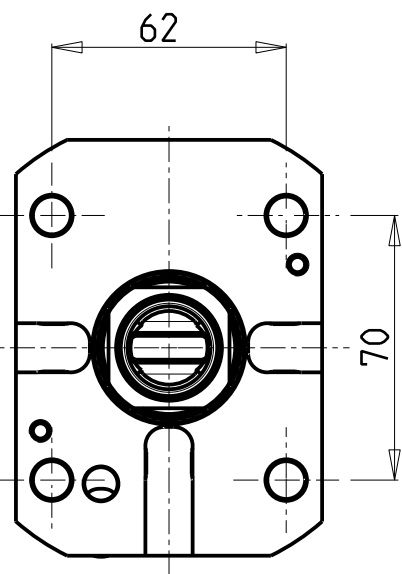

Cod. MT	Cod. MORI-SEIKI	Mandrino Spindle Spindel	I	RPM	Coppia Max Max Torque Max Drehmoment	Lubrificazione int. Coolant through Innenkuehlung	Lubrificazione est. Ext. coolant Aussenkuehlung	CHIAVI NON INCLUSE Keys not included Schlüssel nicht einbegriffen	
MNZ0460125	-	ERA25	1:1	12000	40Nm	P=30bar	X	CHUB27	MNZ0410005

- Chiave inclusa
- Key included
- Schlüssel inbegriffen

DMG-MORI

NZ1500/2000 - NZX1500/2000 - NZX2500 (BMT40) - NL1500/2000/2500 20 STAZ. - NLX1500/2000/2500 20 STAZ.
 NTX1000/2000 - NTX1000/2000/2500/3000 2ND GEN. 12ST. - NRX2000 - ALX1500/2000/2500

MODULO MOTORIZZATO RADIALE 12000 RPM

Radial driven tool 12000 rpm

Radial angetriebenes Werkzeug 12000 rpm

Subject to change without notice.

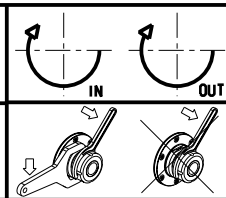

M.T. srl
 Via Casino Albini 480
 Tel. 0541/956034-957884
 Fax 0541/956341
 47842 S. GIOVANNI IN M. (RN)
 e-mail: mtma@mtmarchetti.com
 http://www.mtmarchetti.com



PAGINA MNZ010-1-21

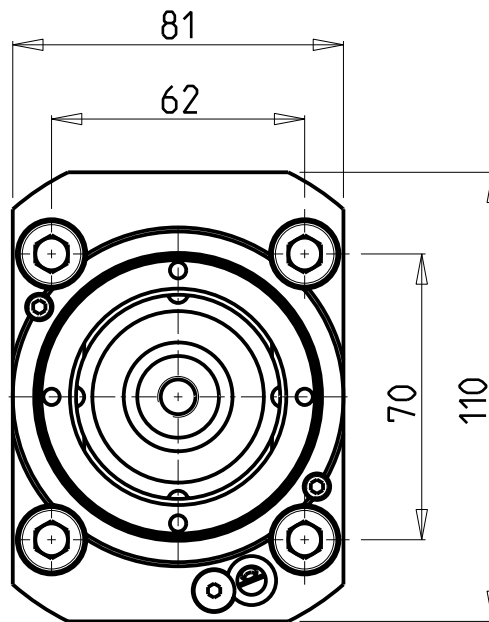
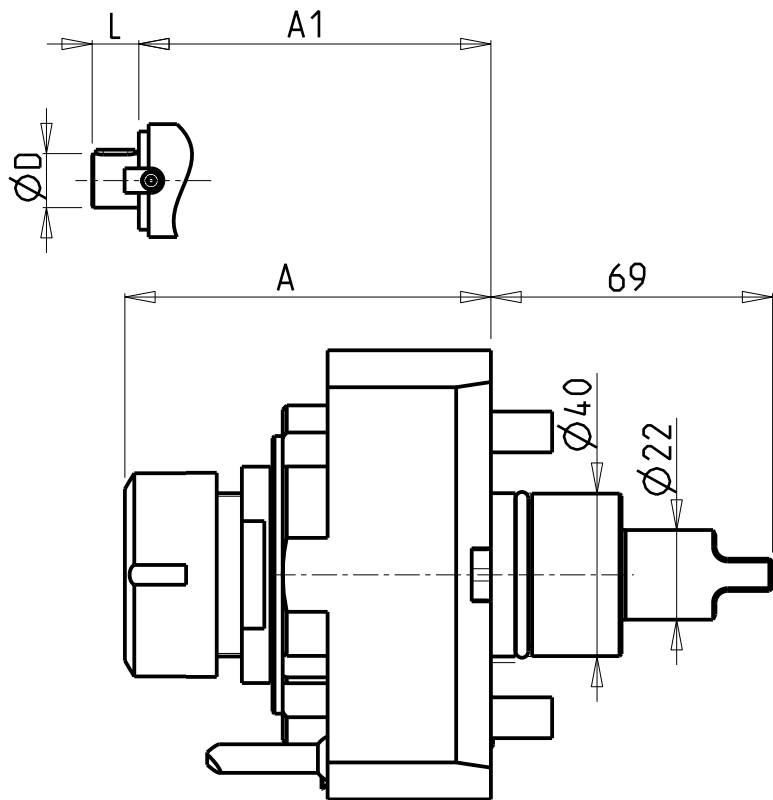

CUSCINETTI MAGGIORATI PER LAVORAZIONI PESANTI

Reinforced bearings for
heavy machining

Vergroesserte lager fuer
schwerere Bearbeitungen

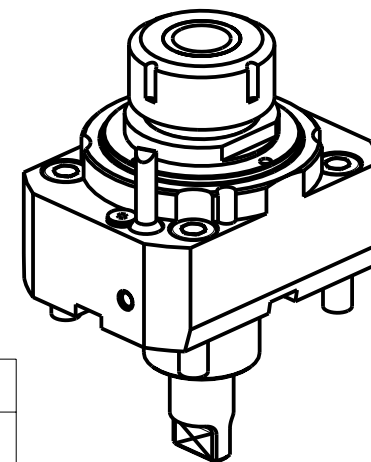

- Chiave inclusa
- Key included
- Schluessel inbegriffen

Cod. MT	Mandrino Spindle Spindel	I	RPM	Coppia Max Max Torque Max Drehmoment	Lubrificazione int. Coolant through Innenkuehlung	Lubrificazione est. Ext. coolant Aussenkuehlung	A	A1	D	L	CHIAVI NON INCLUSE Keys not included Schluessel nicht inbegriffen		
MNZ0360132	ER32	1:1	6000	40Nm		X	89.66	-	-	-	CHSTER32	CHUB46	
MNZ0730440	ERA40	1:1	6000	40Nm	P=70bar	X	89.7	-	-	-	CHTAER40ZC ▪	MNZ0410005 ▪	CHUB36
MNZ0360516	Ø16x17	1:1	6000	40Nm		X	-	68	16	17	CH_VTCROCE_M08 ▪	CHUB46	
MNZ0360519	Ø3/4"x3/4"	1:1	6000	40Nm		X	-	68	3/4"	3/4"	CH_VTCROCE_M08 ▪	CHUB46	
MNZ0360522	Ø22x19	1:1	6000	40Nm		X	-	68	22	19	CH_VTCROCE_M10 ▪	CHUB46	

DMG-MORI

NZ1500/2000 - NZX1500/2000 - NZX2500 (BMT40) - NT3100/3150/3200 - NL1500/2000/2500 20 STAZ. - NLX1500/2000/2500 20 STAZ. - NT1000/2000
NTX1000/2000 - NTX1000/2000/2500/3000 2ND GEN. 12ST. - DURATURN 2050MC/2550MC - NRX2000 - ALX1500/2000/2500 - ECOTURN 450 (BMT40)

MODULO MOTORIZZATO RADIALE MAGGIORATO

Radial reinforced driven tool

Radial angetriebenes Werkzeug vergroessert

Subject to change without notice.

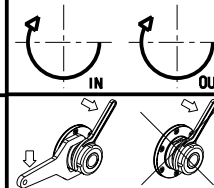

M.T. srl

Via Casino Albini 480
Tel. 0541/956034-957884
Fax 0541/956341

47842 S. GIOVANNI IN M. (RN)
e-mail: mtma@tmarchetti.com
http://www.tmmarchetti.com



PAGINA MNZ020-1-00

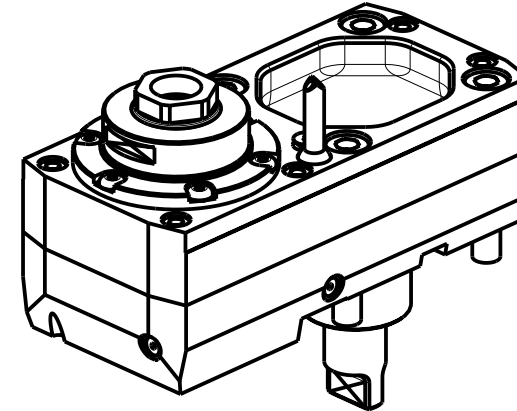
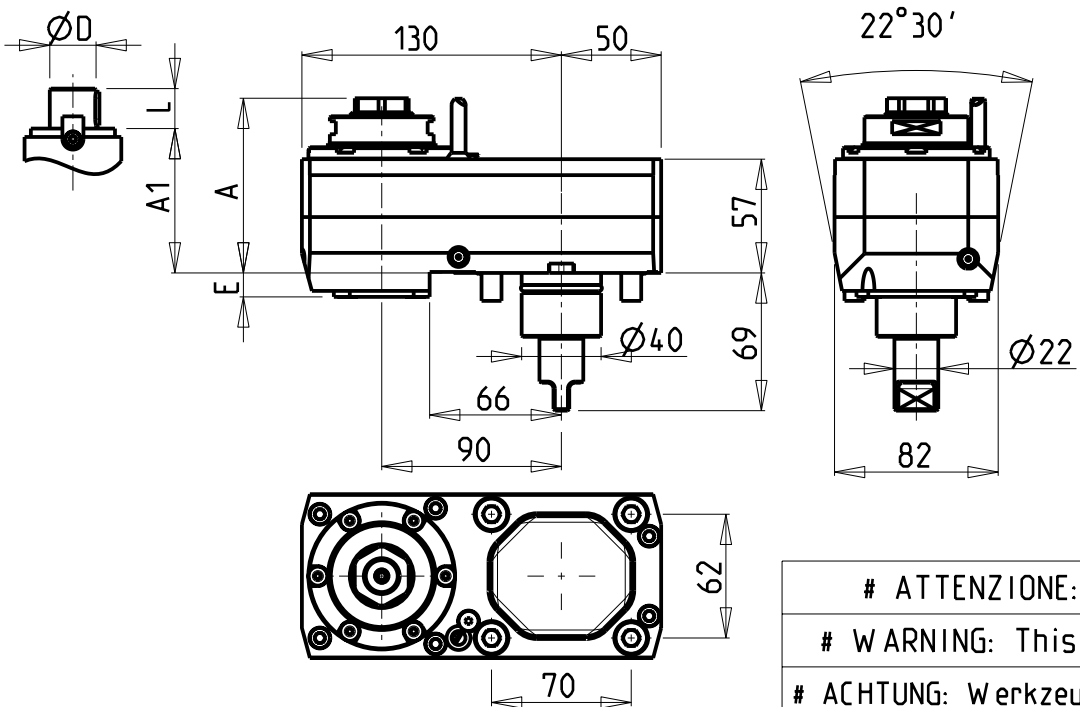

ATTENZIONE: Non si monta su macchine NT3000 SERIE
 # WARNING: This tool can not be mounted on NT3000 SERIES
 # ACHTUNG: Werkzeug darf nicht auf NT3000 SERIEN montiert werden

- Chiave inclusa
- Key included
- Schluessel inbegriffen

Cod. MT	Mandrino Spindle Spindel	I	RPM	Coppia Max Max Torque Max Drehmoment	Reversibile lato mandrino/contromandrino Reversible sub/main spindle side Umkehrbare Spindel-seite/ Gegenspindel-seite	Lu-br.interna Coolant through Innenkuehlung	Lu-br.esterna Ext. coolant Aus-senkuehlung	A	A1	D	L	E	CHIAVI NON INCLUDE Keys not included Schluessel nicht einbegriffen	
MNZ0060220	ER A 20	1:1	6000	40Nm	X		X	81.73	-	-	-	12	CHUB46	CHUB22
MNZ0060225	ER A 25	1:1	6000	40Nm	X		X	87.53	-	-	-	12	CHUB46	CHUB27
MNZ0060232	ER A 32	1:1	6000	40Nm	X		X	95.03	-	-	-	12	CHUB46	CHUB32
MNZ0060425	ER A 25	1:1	6000	40Nm	X	P=70bar	X	87.53	-	-	-	22	CHUB46	CHUB27
MNZ0060432	ER A 32	1:1	6000	40Nm	X	P=70bar	X	95.03	-	-	-	22	CHUB46	CHUB32
MNZ0060216	Ø16x17	1:1	6000	40Nm	X		X	-	75.5	16	17	12	CHUB46	CH_VTCROCE_M08 •
MNZ0060222	Ø22x19	1:1	6000	40Nm	X		X	-	75.5	22	19	12	CHUB46	CH_VTCROCE_M10 •
MNZ0060219	Ø3/4"x3/4"	1:1	6000	40Nm	X		X	-	75.5	3/4"	3/4"	12	CHUB46	CH_VTCROCE_M08 •

DMG-MORI

NZ1500/2000 - NZX1500/2000 - NZX2500 (BMT40) - NT3100/3150/3200 - NL1500/2000/2500 20 STAZ. - NLX1500/2000/2500 20 STAZ. - NT1000/2000 NTX1000/2000 - NTX1000/2000/2500/3000 2ND GEN. 12ST. - DURATURN 2050MC/2550MC - NRX2000 - ALX1500/2000/2500 - ECOTURN 450 (BMT40)

MODULO MOTORIZZATO RADIALE DISASSATO IN Z 90mm

Radial driven tool re-directed in Z by 90mm

Radial angetriebenes Werkzeug achsversetzt in Z um 90mm

Subject to change without notice.

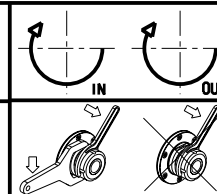

M.T. srl

Via Casino Albini 480
 Tel. 0541/956034-957884
 Fax 0541/956341

47842 S. GIOVANNI IN M. (RN)
 e-mail: mtma@mtmarchetti.com
 http://www.mtmarchetti.com



PAGINA MNZ030-1-10

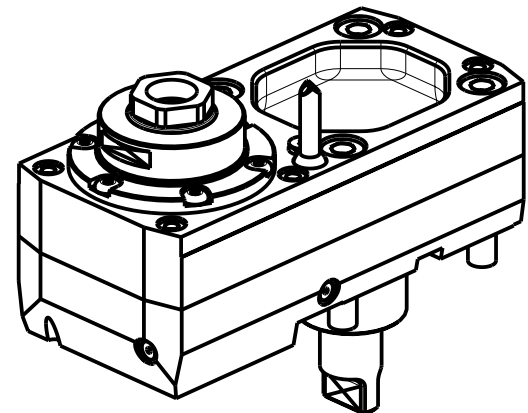
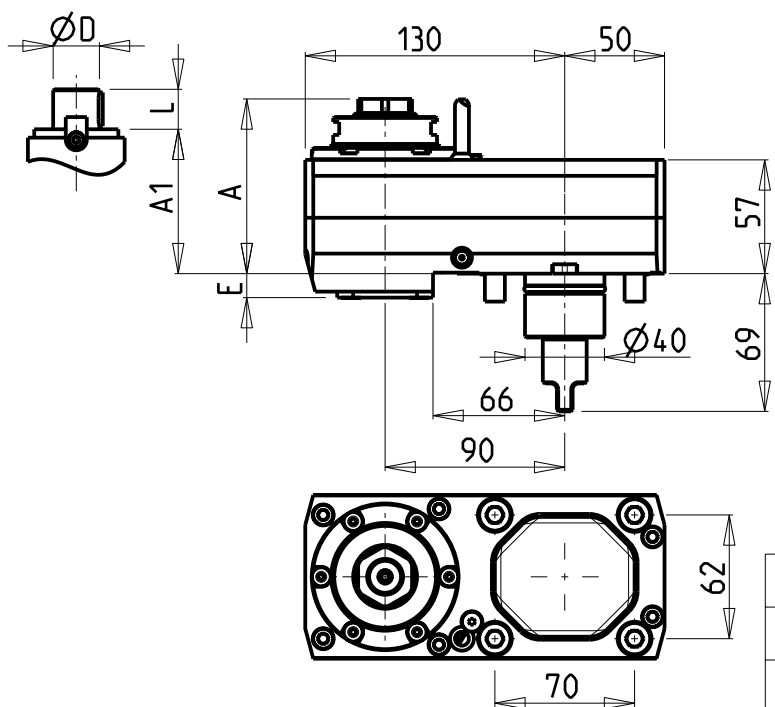

ATTENZIONE: Non si monta su macchine NT3000 SERIE
 # WARNING: This tool can not be mounted on NT3000 SERIES
 # ACHTUNG: Werkzeug darf nicht auf NT3000 SERIEN montiert werden

- Chiave inclusa
- Key included
- Schlüssel inbegriffen

Cod. MT	Mandrino Spindel	I	RPM	Coppia Max Max Torque Max Drehmoment	Reversibile lato mandrino/contromandrino Reversible sub/main spindle side Umkehrbare Spindel-seite/Gegenspindel-seite	Lubr.interna Coolant through Innenkuehlung	Lubr.esterna Ext. coolant Aussenkuehlung	A	A1	D	L	E	CHIAVI NON INCLUDE Keys not included Schluessel nicht einbegriffen	
													CHUB46	CHUB27
MNZ0060125	ER A 25	2:1	3000	60Nm	X	-	X	87.53	-	-	-	12	CHUB46	CHUB27
MNZ0060132	ER A 32	2:1	3000	60Nm	X	-	X	95.03	-	-	-	12	CHUB46	CHUB32
MNZ0060525	ER A 25	2:1	3000	60Nm	X	P=70bar	X	87.53	-	-	-	22	CHUB46	CHUB27
MNZ0060532	ER A 32	2:1	3000	60Nm	X	P=70bar	X	95.03	-	-	-	22	CHUB46	CHUB32
MNZ0060116	Ø16x17	2:1	3000	60Nm	X	-	X	-	75.5	16	17	12	CHUB46	CH_VTCROCE_M08 *
MNZ0060122	Ø22x19	2:1	3000	60Nm	X	-	X	-	75.5	22	19	12	CHUB46	CH_VTCROCE_M10 *
MNZ0060119	Ø3/4"x3/4"	2:1	3000	60Nm	X	-	X	-	75.5	3/4"	3/4"	12	CHUB46	CH_VTCROCE_M08 *

DMG-MORI
 NZ1500/2000 - NZX1500/2000 - NZX2500 (BMT40) - NT3100/3150/3200 - NL1500/2000/2500 20 STAZ. - NLX1500/2000/2500 20 STAZ. - NT1000/2000
 NTX1000/2000 - NTX1000/2000/2500/3000 2ND GEN. 12ST. - DURATURN 2050MC/2550MC - NRX2000 - ALX1500/2000/2500 - ECOTURN 450 (BMT40)

MODULO MOTORIZZATO RADIALE RIDOTTO I=2:1 DISASSATO IN Z 90mm
 Radial geared-down I=2:1 driven tool re-directed in Z by 90mm
 Radial angetriebenes Werkzeug untersetzt I=2:1 achsversetzt in Z um 90mm

Subject to change without notice.

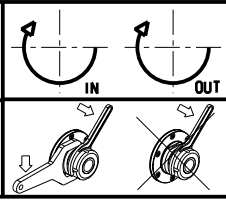

M.T. srl
 Via Casino Albini 480
 Tel. 0541/956034-957884
 Fax 0541/956341
 47842 S. GIOVANNI IN M. (RN)
 e-mail: mtma@mtmarchetti.com
 http://www.mtmarchetti.com



PAGINA MNZ030-1-20

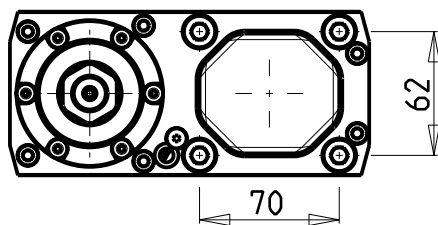
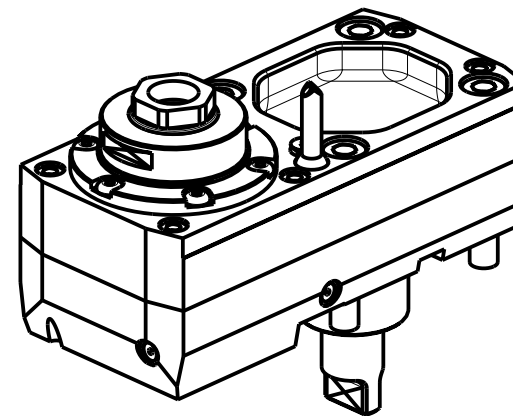
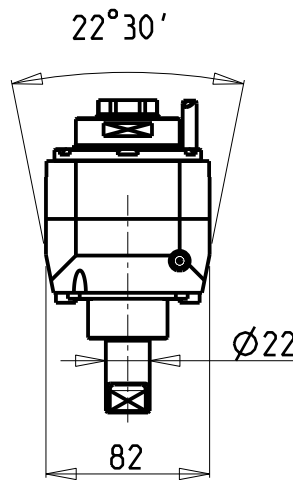
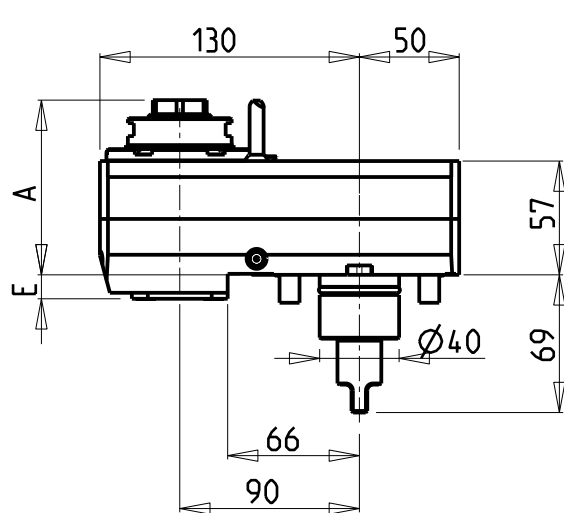

ATTENZIONE: Non si monta su macchine NT3000 SERIE

WARNING: This tool can not be mounted on NT3000 SERIES

ACHTUNG: Werkzeug darf nicht auf NT3000 SERIEN montiert werden

Cod. MT	Mandrino Spindle Spindel	I	RPM	Coppia Max Max Torque Max Drehmoment	Reversibile lato mandrino/contromandrino Reversible sub/main spindle side Umkehrbare Spindel-seite/ Gegenspindel-seite	Lubr.interna Coolant through Innenkuehlung	Lubr.esterna Ext. coolant Ausseinkuehlung	A	E	CHIAVI NON INCLUDE Keys not included Schluessel nicht einbegriffen	
MNZ0060320	ER A 20	1:2	12000	30Nm	X		X	88.73	12	CHUB46	CHUB22
MNZ0060620	ER A 20	1:2	12000	30Nm	X	P=70bar	X	88.73	22	CHUB46	CHUB22
MNZ0060325	ER A 25	1:2	12000	30Nm	X		X	94.53	12	CHUB46	CHUB27

DMG-MORI

NZ1500/2000 - NZX1500/2000 - NZX2500 (BMT40) - NT3100/3150/3200 - NL1500/2000/2500 20 STAZ. - NLX1500/2000/2500 20 STAZ. - NT1000/2000 NTX1000/2000 - NTX1000/2000/2500/3000 2ND GEN. 12ST. - DURATURN 2050MC/2550MC - NRX2000 - ALX1500/2000/2500 - ECOTURN 450 (BMT40)

MODULO MOTORIZZATO RADIALE MOLTIPLICATO I=1:2 DISASSATO IN Z 90mm

Radial geared-up I=1:2 driven tool re-directed in Z by 90mm

Radial angetriebenes Werkzeug uebersetzt I=1:2 achsversetzt in Z um 90mm

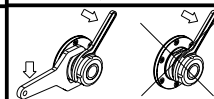
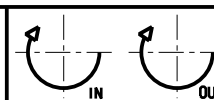

M.T. srl

Via Casino Albini 480
Tel. 0541/956034-957884
Fax 0541/956341

47842 S. GIOVANNI IN M. (RN)
e-mail: mtma@mtmarchetti.com
http://www.mtmarchetti.com



PAGINA MNZ030-1-30

Subject to change without notice.

10/2021

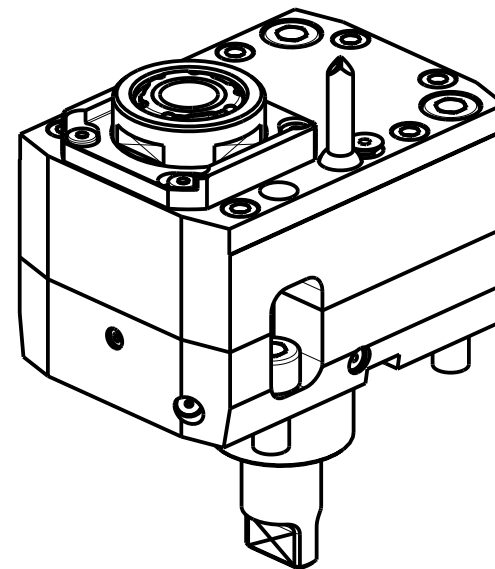
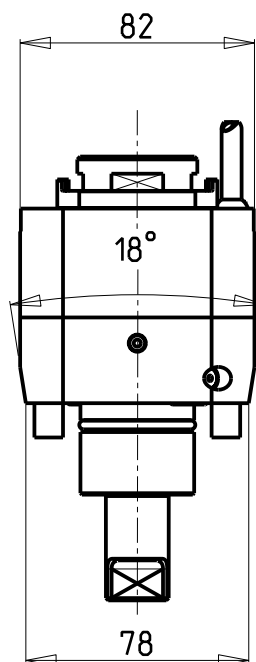
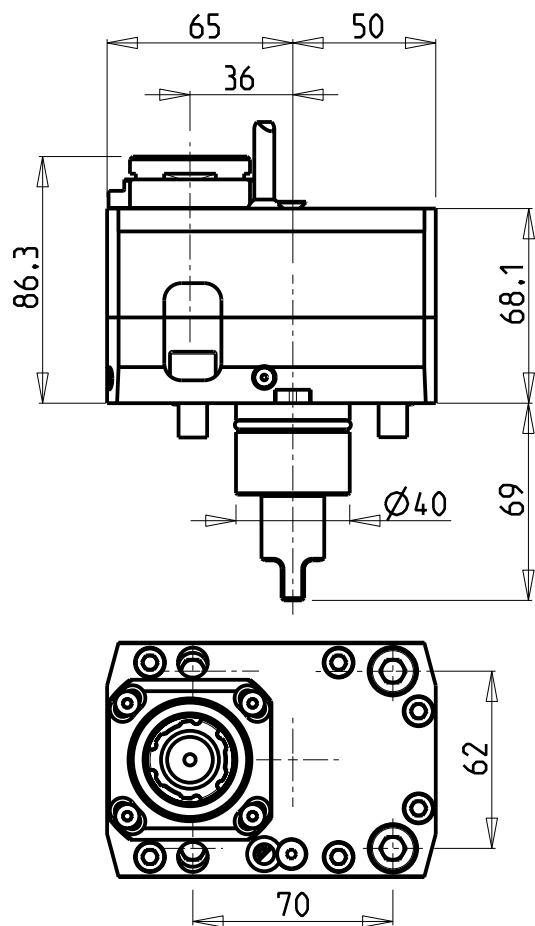

- Chiave inclusa
- Key included
- Schluessel inbegriffen

Cod. MT	Mandrino Spindle Spindel	I	RPM	Coppia Max Max Torque Max Drehmoment	Reversibile lato mandrino/contromandrino Reversible sub/main spindle side Umkehrbare Spindel-seite/ Gegenspindel-seite	Lubr.interna Coolant through Innenkuehlung	Lubr.esterna Ext. coolant Aussenkuehlung	CHIAVI NON INCLUSE Keys not included Schluessel nicht einbegriffen		
					X	-	X	C HUB27	C HTAER25ZC	OKU0290009
MNZ0570325	ERA25	1:1	12000	40Nm	X	-	X	C HUB27	C HTAER25ZC	OKU0290009
MNZ0570425	ERA25	1:1	12000	40Nm	X	P=30bar	X	C HUB27	C HTAER25ZC	OKU0290009

DMG-MORI

NZ1500/2000 - NZX1500/2000 - NZX2500 (BMT40) - NL1500/2000/2500 20 STAZ. - NLX1500/2000/2500 20 STAZ.
 NTX1000/2000 - NTX1000/2000/2500/3000 2ND GEN. - NRX2000 - ALX1500/2000/2500

MODULO MOTORIZZATO RADIALE DISASSATO IN Z 36mm 12000 RPM

Radial driven tool re-directed in Z by 36mm 12000 rpm

Radial angetriebenes Werkzeug achsversetzt in Z um 36mm 12000 rpm

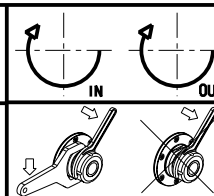

M.T. srl

Via Casino Albini 480
 Tel. 0541/956034-957884
 Fax 0541/956341
 47842 S. GIOVANNI IN M. (RN)
 e-mail: mtma@mtmarchetti.com
 http://www.mtmarchetti.com



PAGINA MNZ033-1-11

ATTENZIONE - ATTENTION - ACHTUNG

- Per lo smontaggio degli utensili utilizzare sempre la chiave di contrasto come indicato nel manuale d'uso.
- For disassembly of the tools use always the contrast key as mentioned in the user instructions.
- Fuer das Abmontieren der Werkzeuge immer den Gegenschlüssel benutzen wie in der Bedienungsanleitung erwaeht.

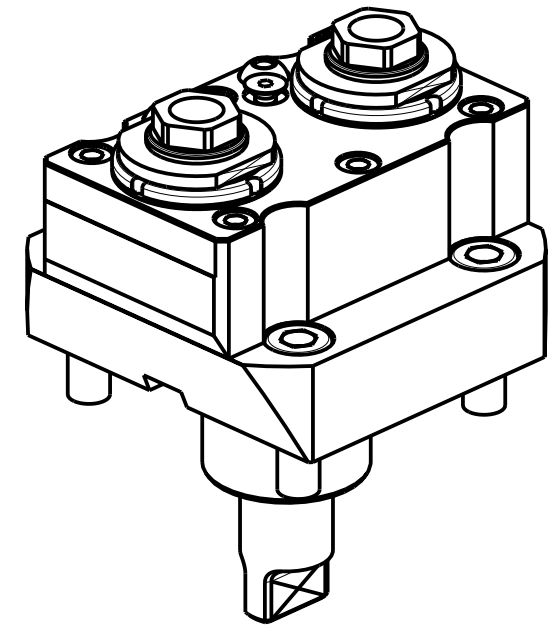
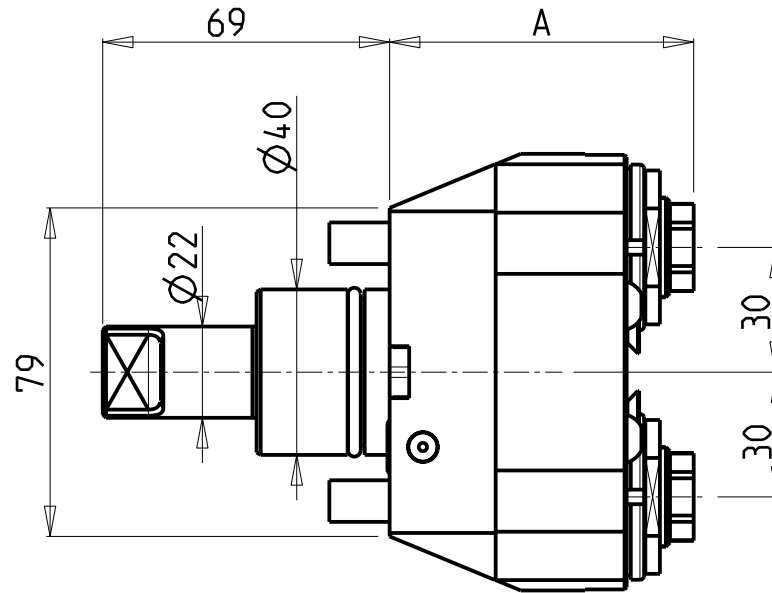
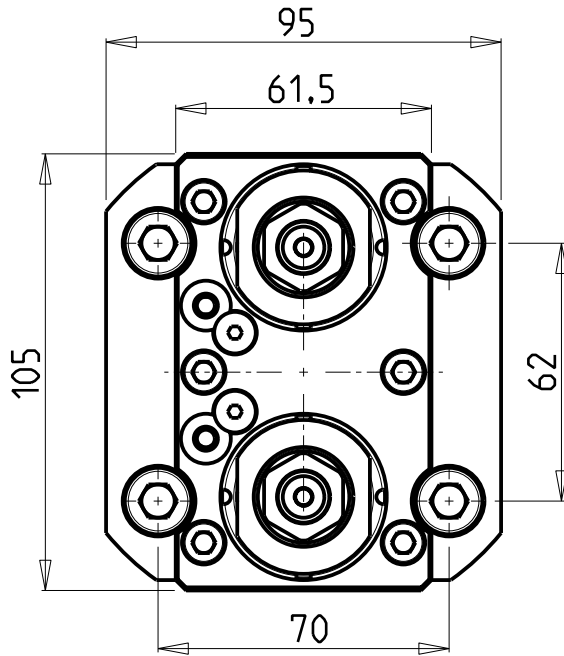

Cod. MT	Mandrino Spindle Spindel	I	RPM	Coppia Max Max Torque Max Drehmoment	Lubrificazione int. Coolant through Innenkuehlung	Lubrificazione est. Ext. coolant Aussenkuehlung	A	CHIAVI NON INCLUSE Keys not included Schlüssel nicht einbegriffen	
MNZ0030416	ERA16	1:1	6000	30Nm	-	X	73.13	CHUB32	CHUB19_SP3
MNZ0030516	ERA16	1:1	6000	30Nm	P=70bar	X	83.13	CHUB32	CHUB19_SP3
MNZ0030420	ER20	1:1	6000	30Nm	-	X	89.66	CHUB32	CHSTER20
MNZ0680220	ER20	1:1	6000	30Nm	P=70bar	X	96.16	CHUB32	CHSTER20

DMG-MORI

NZ1500/2000 - NZX1500/2000 - NT3100/3150/3200 - NL1500/2000/2500 20 STAZ. - NLX1500/2000/2500 20 STAZ. - NT1000/2000
 NTX1000/2000/2500/3000 2ND GEN. 12ST. - DURATURN 2050MC/2550MC - ALX1500/2000/2500 - ECOTURN 450 (BMT40)

MODULO MOTORIZZATO RADIALE 2 USCITE IN Y

Radial single side twin head driven tool in Y

Radial angetriebenes Werkzeug 2 Ausgaenge ueberlagert in Y

Subject to change without notice.

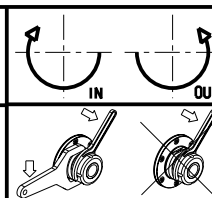

M.T. srl

Via Casino Albini 480
 Tel. 0541/956034-957884
 Fax 0541/956341
 47842 S. GIOVANNI IN M. (RN)
 e-mail: mtma@mtmarchetti.com
 http://www.mtmarchetti.com



PAGINA MNZ080-1-00

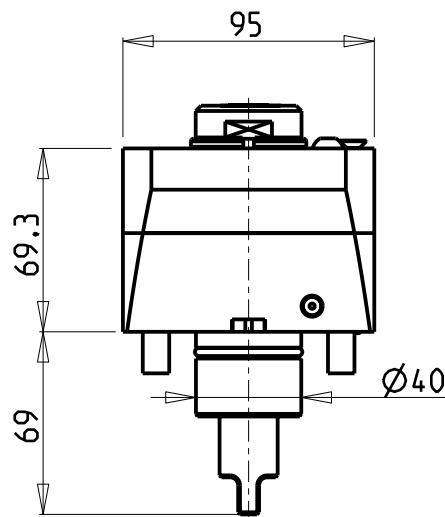
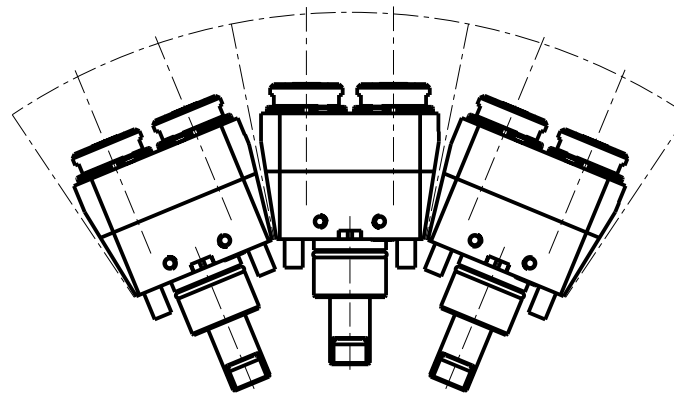
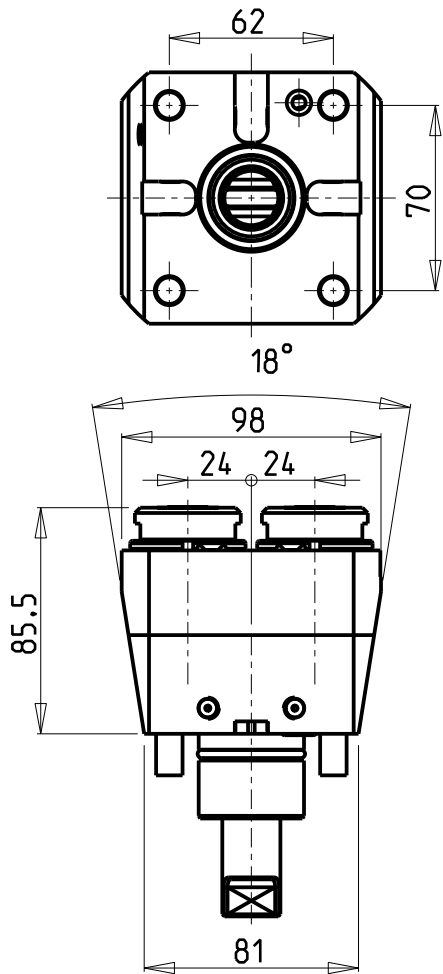

ATTENZIONE - ATTENTION - ACHTUNG

- Per lo smontaggio degli utensili utilizzare sempre la chiave di contrasto come indicato nel manuale d'uso.
- For disassembly of the tools use always the contrast key as mentioned in the user instructions.
- Fuer das Abmontieren der Werkzeuge immer den Gegenschlüssel benutzen wie in der Bedienungsanleitung erwaeht.

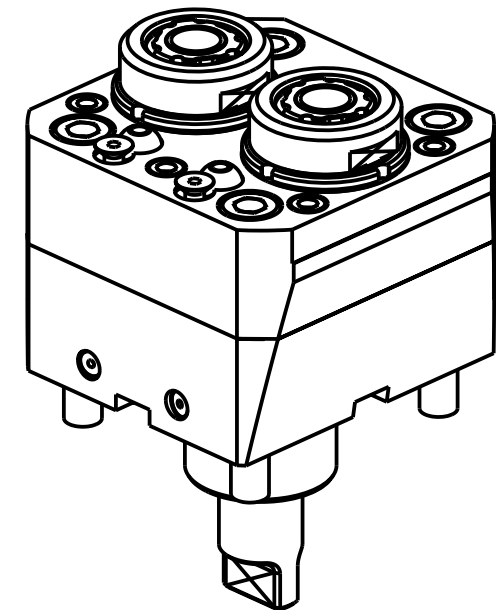

- Chiave inclusa
- Key included
- Schluessel inbegriffen

Cod. MT	Mandrino Spindle Spindel	I	RPM	Coppia Max Max Torque Max Drehmoment	Lubrificazione int. Coolant through Innenkuehlung	Lubrificazione est. Ext. coolant Aussenkuehlung	CHIAVI NON INCLUSE Keys not included Schluessel nicht einbegriffen		
MNZ0690320	ERA20	1:1	6000	30Nm	-	X	CHUB36	CHUB22	CHTAER20ZC ▪
MNZ0690420	ERA20	1:1	6000	30Nm	P=70bar	X	CHUB36	CHUB22	CHTAER20ZC ▪

DMG-MORI

NZ1500/2000 - NZX1500/2000 - NT3100/3150/3200 - NL1500/2000/2500 20 STAZ. - NLX1500/2000/2500 20 STAZ. - NT1000/2000
NTX1000/2000/2500/3000 2ND GEN. 12ST. - DURATURN 2050MC/2550MC - ALX1500/2000/2500 - ECOTURN 450 (BMT40)

MODULO MOTORIZZATO RADIALE 2 USCITE IN Y

Radial single side twin head driven tool in Y

Radial angetriebenes Werkzeug 2 Ausgaenge ueberlagert in Y

Subject to change without notice.

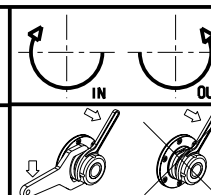

M.T. srl

Via Casino Albini 480
Tel. 0541/956034-957884
Fax 0541/956341
47842 S. GIOVANNI IN M. (RN)
e-mail: mtma@mtmarchetti.com
http://www.mtmarchetti.com



PAGINA MNZ080-1-05

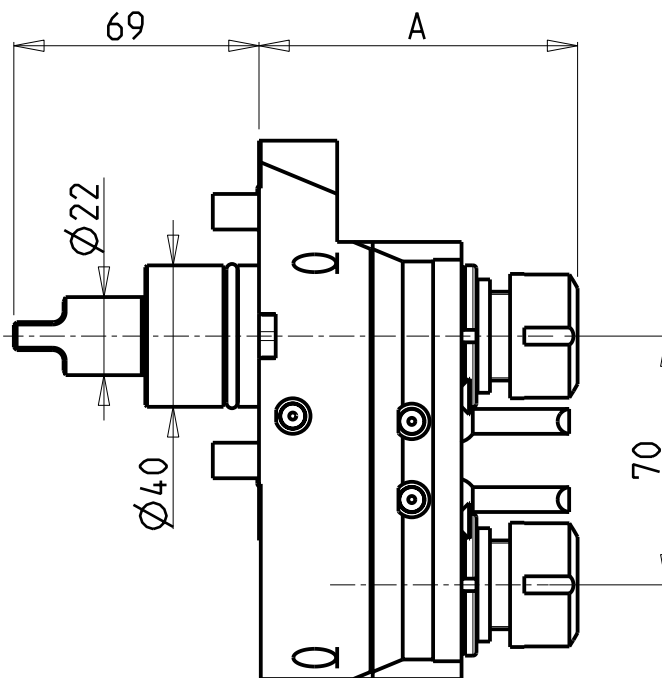
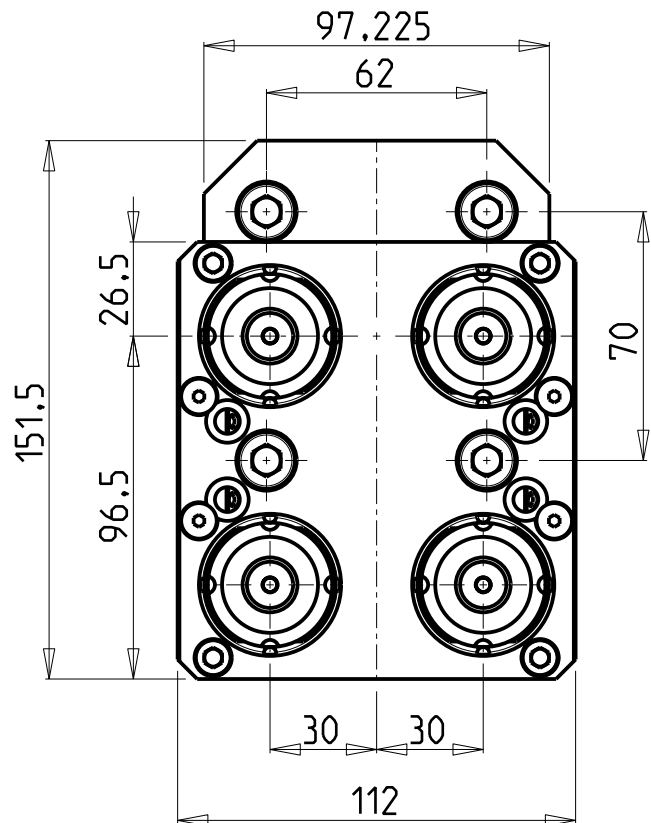

ATTENZIONE - ATTENTION - ACHTUNG

- Per lo smontaggio degli utensili utilizzare sempre la chiave di contrasto come indicato nel manuale d'uso.
- For disassembly of the tools use always the contrast key as mentioned in the user instructions.
- Fuer das Abmontieren der Werkzeuge immer den Gegenschlüssel benutzen wie in der Bedienungsanleitung erwaeht.

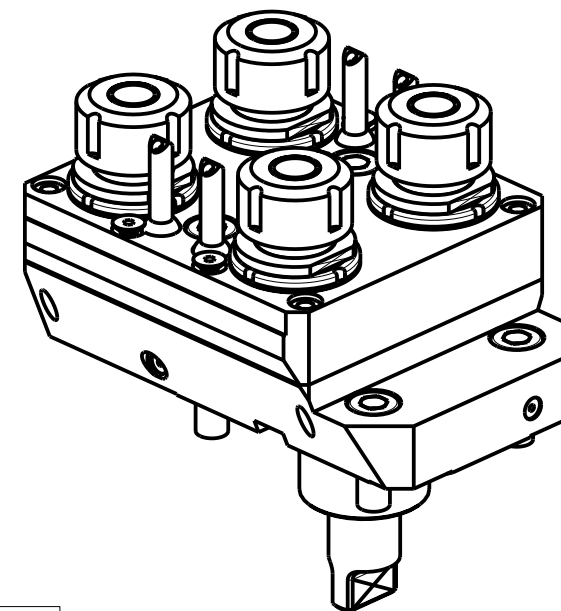

Cod. MT	Mandrino Spindle Spindel	I	RPM	Coppia Max Max Torque Max Drehmoment	N°Utensili N°Tools N°Werkzeuge	Reversibile lato mandrino/contromandrino Reversible sub/main spindle side Umkehrbare Spindel-seite/ Gegenspindel-seite	Lubrificazione est. Ext. coolant Auslenkuehlung	A	CHIAVI INCLUSE Keys included Schlüssel einbegriffen	
									CHUB32	CHSTER16
MNZ0030116	ER16	1:1	6000	30Nm	4	X	X	67.26	CHUB32	CHSTER16
MNZ0030120	ER20	1:1	6000	30Nm	4	X	X	89.66	CHUB32	CHSTER20

DMG-MORI

NZ1500/2000 - NZX1500/2000 - NT3100/3150/3200 - NL1500/2000/2500 20 STAZ. - NLX1500/2000/2500 20 STAZ. - NT1000/2000
NTX1000/2000/2500/3000 2ND GEN. 12ST. - DURATURN 2050MC/2550MC - ALX1500/2000/2500 - ECOTURN 450 (BMT40)

MODULO MOTORIZZATO RADIALE 4 USCITE

Radial 4 head driven tool

Radial angetriebenes Werkzeug 4 Ausgaenge

Subject to change without notice.

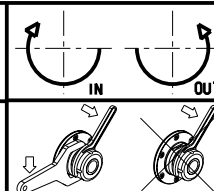

M.T. srl

Via Casino Albini 480
Tel. 0541/956034-957884
Fax 0541/956341

47842 S. GIOVANNI IN M. (RN)
e-mail: mtma@mtmarchetti.com
http://www.mtmarchetti.com



PAGINA MNZ100-1-00

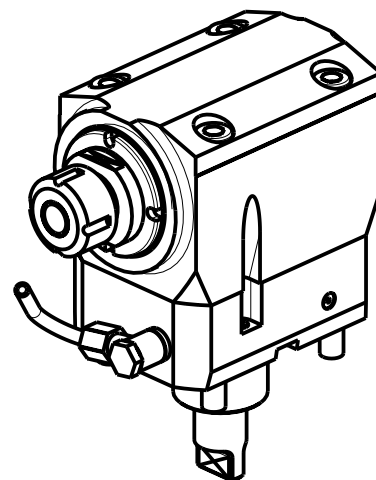
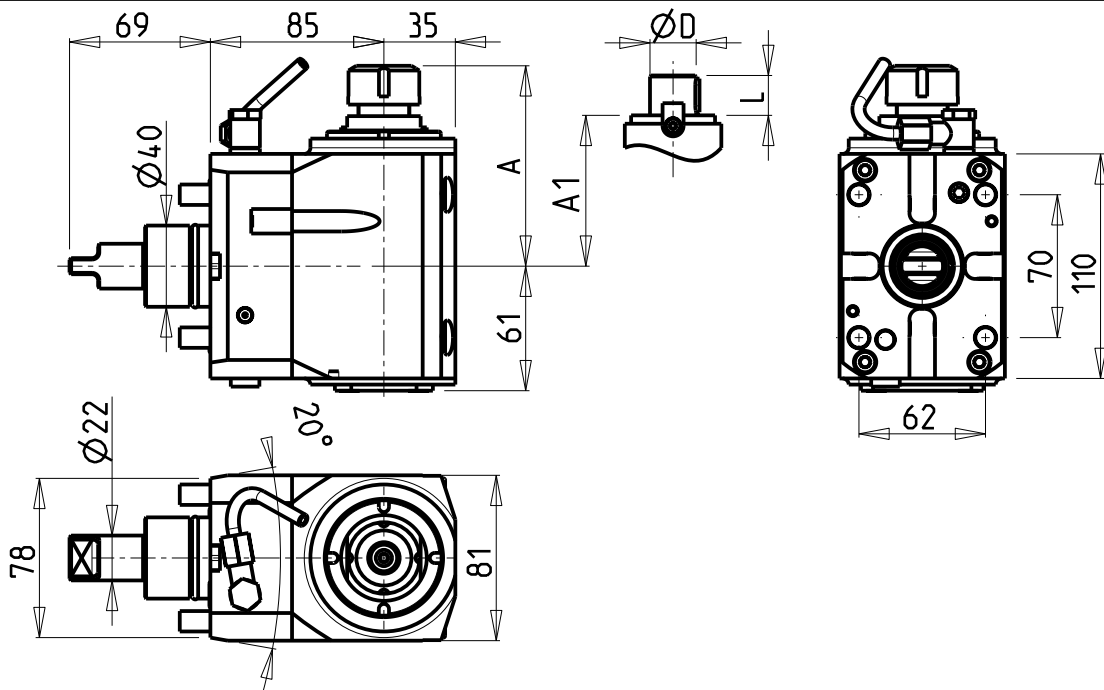

ATTENZIONE - ATTENTION - ACHTUNG

- Per lo smontaggio degli utensili utilizzare sempre la chiave di contrasto come indicato nel manuale d'uso.
- For disassembly of the tools use always the contrast key as mentioned in the user instructions.
- Fuer das Abmontieren der Werkzeuge immer den Gegenschlüssel benutzen wie in der Bedienungsanleitung erwäehnt.

- Chiave inclusa
- Key included
- Schlüssel inbegriffen

Cod. MT	Cod. MORI-SEIKI	Mandrino Spindle Spindel	I	RPM	Coppia Max Max Torque Max Drehmoment	Reversibile lato mandrino/contromandrino Reversible sub/main spindle side Umkehrbare Spindel-seite/ Gegenspindel-seite	Lubr.interna Coolant through Innenkuehlung	Lubr.esterna Ext. coolant Aussenkuehlung	A	A1	B	D	L	CHIAVI NON INCLUDE Keys not included Schluessel nicht einbegriffen	
MNZ0010120	T32255	ER20	1:1	6000	40Nm	X		X	98.16	-	61	-	-	CHUB36	CHSTER20
MNZ0010125	T32275	ER25	1:1	6000	40Nm	X		X	99.16	-	61	-	-	CHUB36	CHSTER25
MNZ0010132		ER32	1:1	6000	40Nm	X		X	102.16	-	61	-	-	CHUB36	CHSTER32
MNZ0010225		ER25	1:1	6000	40Nm	X	P=70bar	X	99.16	-	71	-	-	CHUB36	CHSTER25
MNZ0010232		ER32	1:1	6000	40Nm	X	P=70bar	X	102.76	-	71	-	-	CHUB36	CHSTER32
MNZ0011617		Ø16x17	1:1	6000	40Nm	X		X	-	76.5	61	16	17	CHUB36	CH_VTCROCE_M08 •
MNZ0012219		Ø22x19	1:1	6000	40Nm	X		X	-	78.5	61	22	19	CHUB36	CH_VTCROCE_M10 •
MNZ0012721		Ø27x21	1:1	6000	40Nm	X		X	-	79.5	61	27	21	CHUB36	CH_VTCROCE_M12 •
MNZ0011919		Ø3/4"x3/4"	1:1	6000	40Nm	X		X	-	77	61	3/4"	3/4"	CHUB36	CH_VTCROCE_M08 •

DMG-MORI

NZ1500/2000 - NZX1500/2000 - NZX2500 (BMT40) - NT3100/3150/3200 - NL1500/2000/2500 20 STAZ. - NLX1500/2000/2500 20 STAZ. - NT1000/2000 NTX1000/2000 - NTX1000/2000/2500/3000 2ND GEN. 12ST. - DURATURN 2050MC/2550MC - NRX2000 - ALX1500/2000/2500 - ECOTURN 450 (BMT40)

MODULO MOTORIZZATO ASSIALE H=85mm

Axial driven tool H=85mm

Axial angetriebenes Werkzeug H=85mm

Subject to change without notice.

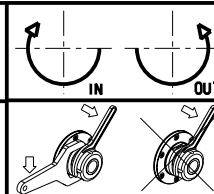

M.T. srl

Via Casino Albini 480
Tel. 0541/956034-957884
Fax 0541/956341

47842 S. GIOVANNI IN M. (RN)
e-mail: mtma@tmarchetti.com
http://www.tmmarchetti.com



PAGINA MNZ150-1-10

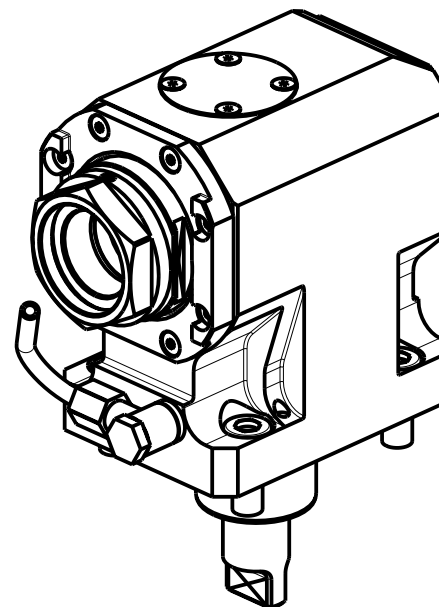
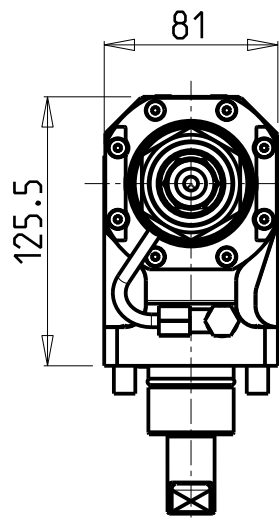
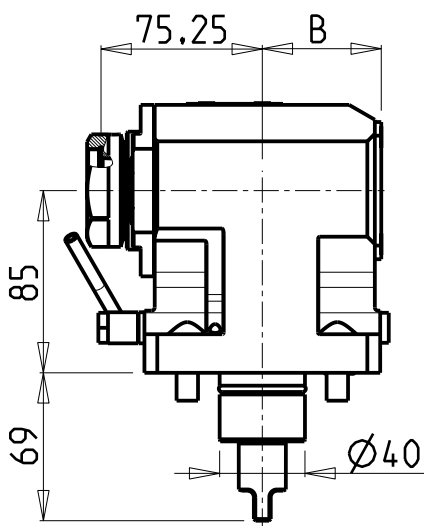
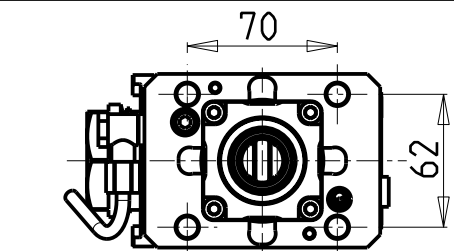

ATTENZIONE - ATTENTION - ACHTUNG

- Per lo smontaggio degli utensili utilizzare sempre la chiave di contrasto come indicato nel manuale d'uso.
- For disassembly of the tools use always the contrast key as mentioned in the user instructions.
- Fuer das Abmontieren der Werkzeuge immer den Gegenschlüssel benutzen wie in der Bedienungsanleitung erwäehnt.

PER PORTAUTENSILI MODULARI MTSK-40 VEDI PAG. TBL300-1-40
 FOR MTSK-40 QUIK CHANGE TOOLHOLDERS CLAMPINGS SEE PAGE TBL300-1-40
 FUER MTSK-40 MODULARE WERKZEUGAUFNAHMEN SIEHE SEITE TBL300-1-40

Cod. MT	Mandrino Spindle Spindel	I	RPM	Coppia Max Max Torque Max Drehmoment	Reversibile lato mandrino/contromandrino Reversible sub/main spindle side Umkehrbare Spindel-seite/ Gegenspindel-seite	Lubr.interna Coolant through Innenkuehlung	Lubr.esterna Ext. coolant Aussenkuehlung	B	CHIAVI NON INCLUSE Keys not included Schluessel nicht einbegriffen	
MNZ0400140	MTSK-40	1:1	6000	40Nm	X		X	55.5	CHUB46	MNZ0410005 •
MNZ0400240	MTSK-40	1:1	6000	40Nm	X	P=70bar	X	68	CHUB46	MNZ0410005 •

- Chiave inclusa
- Key included
- Schluessel inbegriffen

DMG-MORI

NZ1500/2000 - NZX1500/2000 - NZX2500 (BMT40) - NT3100/3150/3200 - NL1500/2000/2500 20 STAZ. - NLX1500/2000/2500 20 STAZ. - NT1000/2000
 NTX1000/2000 - NTX1000/2000/2500/3000 2ND GEN. 12ST. - DURATURN 2050MC/2550MC - NRX2000 - ALX1500/2000/2500 - ECOTURN 450 (BMT40)

MODULO MOTORIZZATO ASSIALE MTSK

Axial MTSK driven tool

Axial MTSK angetriebenes Werkzeug

Subject to change without notice.

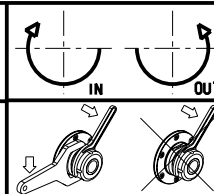

M.T. srl

Via Casino Albini 480
 Tel. 0541/956034-957884
 Fax 0541/956341
 47842 S. GIOVANNI IN M. (RN)
 e-mail: mtma@mtmarchetti.com
 http://www.mtmarchetti.com



PAGINA MNZ150-1-10-K

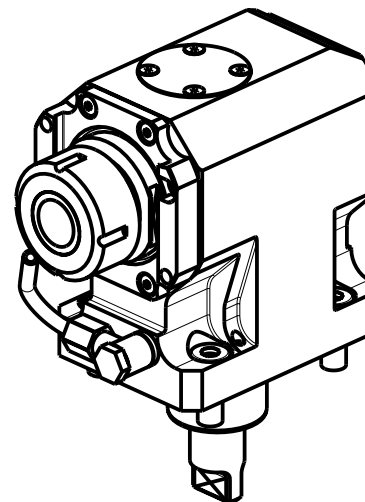
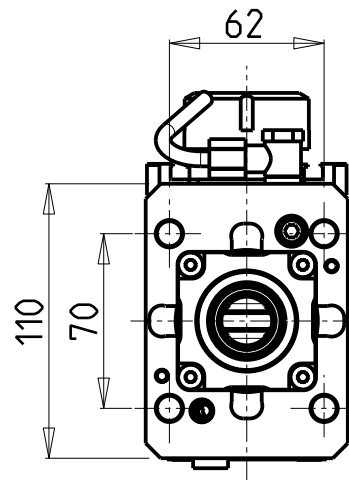
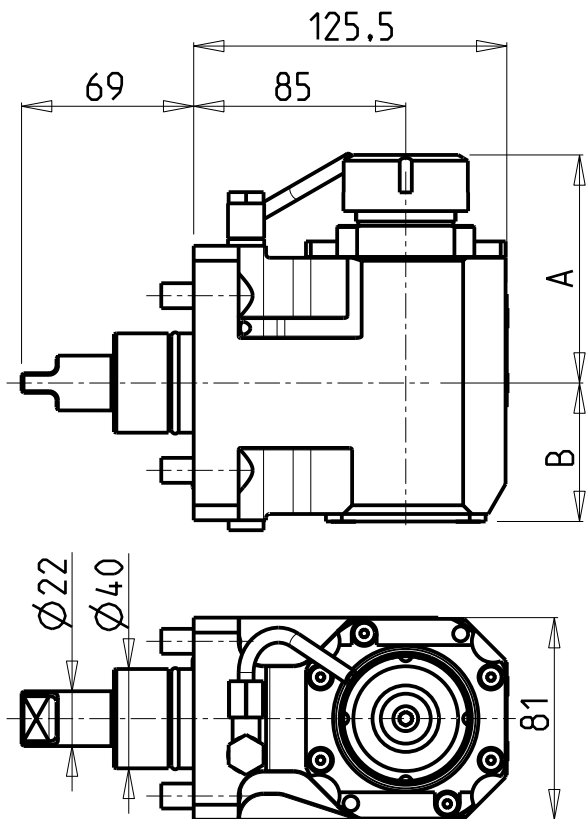

ATTENZIONE - ATTENTION - ACHTUNG

- Per lo smontaggio degli utensili utilizzare sempre la chiave di contrasto come indicato nel manuale d'uso.
- For disassembly of the tools use always the contrast key as mentioned in the user instructions.
- Fuer das Abmontieren der Werkzeuge immer den Gegenschlüssel benutzen wie in der Bedienungsanleitung erwäehnt.

- Chiave inclusa
- Key included
- Schluesel inbegriffen

Cod. MT	Mandrino Spindle Spindel	I	RPM	Coppia Max Max Torque Max Drehmoment	Reversibile lato mandrino/contromandrino Reversible sub/main spindle side Umkehrbare Spindelseite/ Gegenspindelseite	Lubr.interna Coolant through Innenkuehlung	Lubr.esterna Ext. coolant Aussenkuehlung	A	B	CHIAVI NON INCLUDE Keys not included Schluesel nicht einbegriffen	
MNZ0470125	ER25	1:1	12000	40Nm	X	-	X	88.4	55.5	CHSTER25	MNZ0410005 ▪
MNZ0470225	ER25	1:1	12000	40Nm	X	P=70bar	X	88.4	68	CHSTER25	MNZ0410005 ▪
MNZ0470132	ER32	1:1	12000	40Nm	X	-	X	91.4	55.5	CHSTER32	MNZ0410005 ▪
MNZ0470232	ER32	1:1	12000	40Nm	X	P=70bar	X	91.4	68	CHSTER32	MNZ0410005 ▪

DMG-MORI
 NZ1500/2000 - NZX1500/2000 - NZX2500 (BMT40) - NL1500/2000/2500 20 STAZ. - NLX1500/2000/2500 20 STAZ.
 NTX1000/2000 - NTX1000/2000/2500/3000 2ND GEN. 12ST. - NRX2000 - ALX1500/2000/2500

MODULO MOTORIZZATO ASSIALE 12000 RPM H=85mm
 Axial driven tool 12000 rpm H=85mm
 Axial angetriebenes Werkzeug 12000 rpm H=85mm

Subject to change without notice.

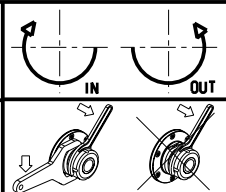

M.T. srl
 Via Casino Albini 480
 Tel. 0541/956034-957884
 Fax 0541/956341
 47842 S. GIOVANNI IN M. (RN)
 e-mail: mtma@tmarchetti.com
 http://www.tmmarchetti.com



PAGINA MNZ150-1-11

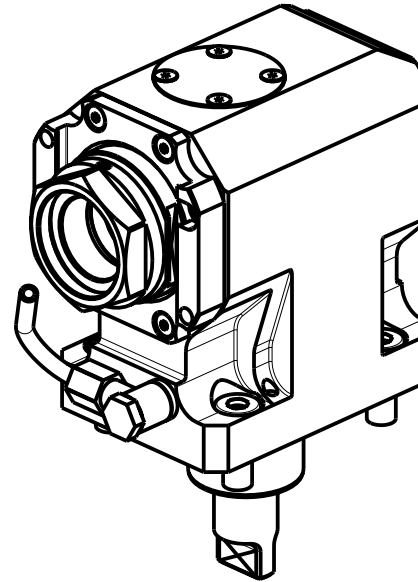
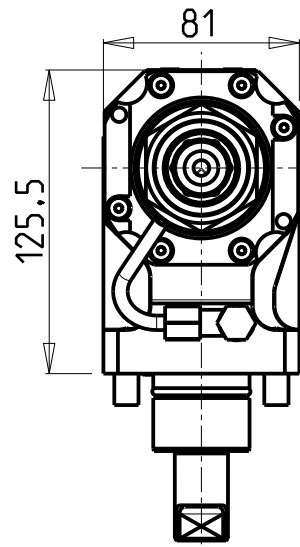
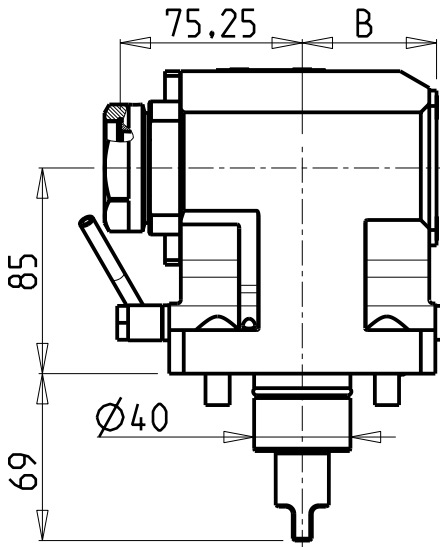
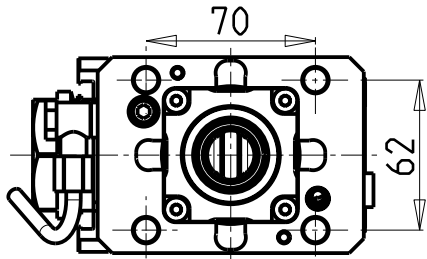

ATTENZIONE - ATTENTION - ACHTUNG

- Per lo smontaggio degli utensili utilizzare sempre la chiave di contrasto come indicato nel manuale d'uso.
- For disassembly of the tools use always the contrast key as mentioned in the user instructions.
- Fuer das Abmontieren der Werkzeuge immer den Gegenschlüssel benutzen wie in der Bedienungsanleitung erwaehtnt.

PER PORTAUTENSILI MODULARI MTSK-40 VEDI PAG. TBL300-1-40
 FOR MTSK-40 QUIK CHANGE TOOLHOLDERS CLAMPINGS SEE PAGE TBL300-1-40
 FUER MTSK-40 MODULARE WERKZEUGAUFNAHMEN SIEHE SEITE TBL300-1-40

Cod. MT	Mandrino Spindle Spindel	I	RPM	Coppia Max Max Torque Max Drehmoment	Reversibile lato mandrino/contromandrino Reversible sub/main spindle side Umkehrbare Spindel-seite/ Gegenspindel-seite	Lubr.interna Coolant through Innenkuehlung	Lubr.esterna Ext. coolant Aussenkuehlung	B	CHIAVI NON INCLUSE Keys not included Schluessel nicht einbegriffen
MNZ0480140	MTSK-40	1:1	12000	40Nm	X	-	X	55.5	CHUB46 MNZ0410005 •
MNZ0480240	MTSK-40	1:1	12000	40Nm	X	P=70bar	X	68	CHUB46 MNZ0410005 •

- Chiave inclusa
- Key included
- Schluessel inbegriffen

DMG-MORI

NZ1500/2000 - NZX1500/2000 - NZX2500 (BMT40) - NL1500/2000/2500 20 STAZ. - NLX1500/2000/2500 20 STAZ.
 NTX1000/2000 - NTX1000/2000/2500/3000 2ND GEN. 12ST. - NRX2000 - ALX1500/2000/2500

MODULO MOTORIZZATO ASSIALE MTSK 12000 RPM H=85mm

Axial MTSK driven tool 12000 rpm H=85mm

Axial MTSK angetriebenes Werkzeug 12000 rpm H=85mm

Subject to change without notice.

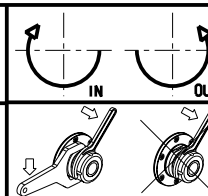

M.T. srl

Via Casino Albini 480
 Tel. 0541/956034-957884
 Fax 0541/956341
 47842 S. GIOVANNI IN M. (RN)
 e-mail: mtma@tmarchetti.com
 http://www.tmmarchetti.com



PAGINA MNZ150-1-11-K

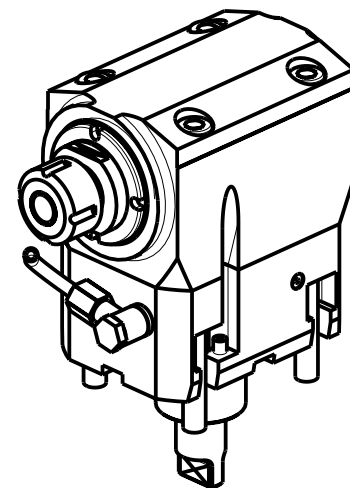
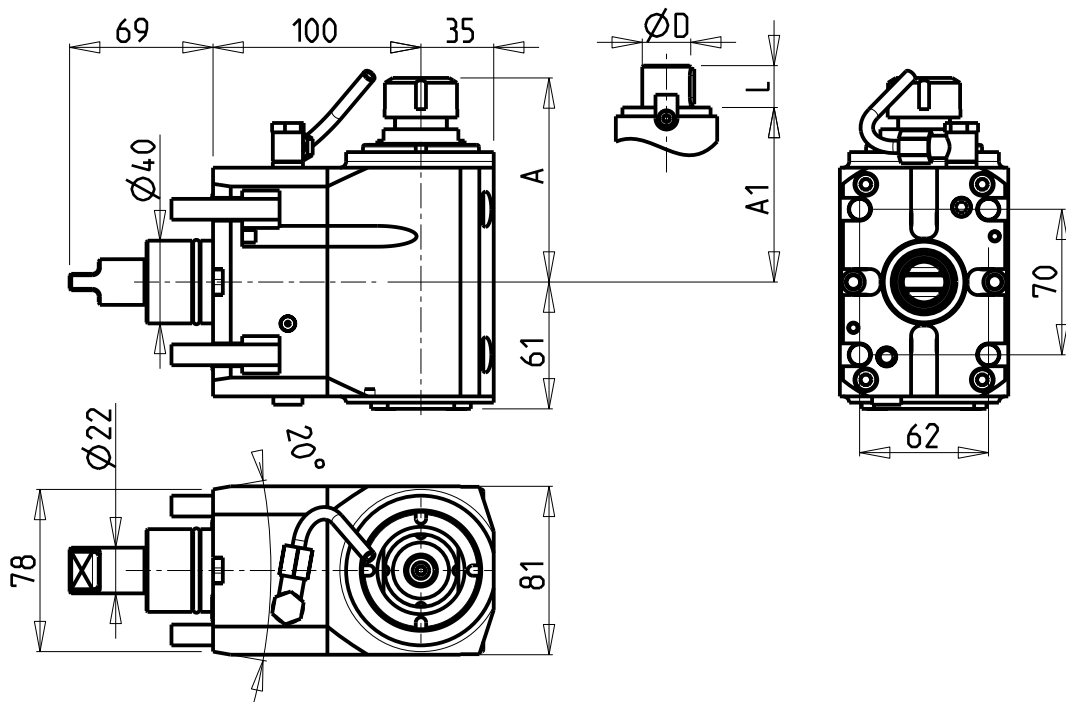

- Chiave inclusa
- Key included
- Schlüssel inbegriffen

ATTENZIONE - ATTENTION - ACHTUNG

- Per lo smontaggio degli utensili utilizzare sempre la chiave di contrasto come indicato nel manuale d'uso.
- For disassembly of the tools use always the contrast key as mentioned in the user instructions.
- Für das Abmontieren der Werkzeuge immer den Gegenschlüssel benutzen wie in der Bedienungsanleitung erwähnt.

ATTENZIONE - ATTENTION - ACHTUNG

- VERIFICARE LE MISURE DI INGOMBRO PER POSSIBILE INTERFERENZA SU ALCUNI MODELLI DI MACCHINE
- Please check the overall sizes for possible interferences on some machine models
- Bitte überprüfen sie das ausmass um mögliche interferenzen auf einigen maschinen modellen zu vermeiden

Cod. MT	Mandrino Spindle Spindel	I	RPM	Coppia Max Max Torque Max Drehmoment	Reversibile lato mandrino/contromandrino Reversible sub/main spindle side Umkehrbare Spindel-seite/ Gegen-spindel-seite	Lubr.interna Coolant through Innenkuehlung	Lubr.esterna Ext. coolant Ausseinkuehlung	A	A1	B	D	L	CHIAVI NON INCLUDE Keys not included Schlüssel nicht einbegriffen	
MNZ0210120	ER20	1:1	6000	40Nm	X		X	98.16	-	61	-	-	CHUB36	CHSTER20
MNZ0210125	ER25	1:1	6000	40Nm	X		X	99.16	-	61	-	-	CHUB36	CHSTER25
MNZ0210132	ER32	1:1	6000	40Nm	X		X	102.16	-	61	-	-	CHUB36	CHSTER32
MNZ0210225	ER25	1:1	6000	40Nm	X	P=70bar	X	99.16	-	71	-	-	CHUB36	CHSTER25
MNZ0210232	ER32	1:1	6000	40Nm	X	P=70bar	X	102.76	-	71	-	-	CHUB36	CHSTER32
MNZ0211617	Ø16x17	1:1	6000	40Nm	X		X	-	76.5	61	16	17	CHUB36	CH_VTCROCE_M08 ■
MNZ0212219	Ø22x19	1:1	6000	40Nm	X		X	-	78.5	61	22	19	CHUB36	CH_VTCROCE_M10 ■
MNZ0212721	Ø27x21	1:1	6000	40Nm	X		X	-	79.5	61	27	21	CHUB36	CH_VTCROCE_M12 ■
MNZ0211919	Ø3/4"x3/4"	1:1	6000	40Nm	X		X	-	77	61	3/4"	3/4"	CHUB36	CH_VTCROCE_M08 ■

DMG-MORI

NZ1500/2000 - NZX1500/2000 - NT3100/3150/3200 - NL1500/2000/2500 20 STAZ. - NLX1500/2000/2500 20 STAZ.
 NT1000/2000 - NTX1000/2000 - NTX1000/2000/2500/3000 2ND GEN. 12ST. - DURATURN 2050MC/2550MC - ALX1500/2000/2500

MODULO MOTORIZZATO ASSIALE H=100mm

Axial driven tool H=100mm

Axial angetriebenes Werkzeug H=100mm

Subject to change without notice.

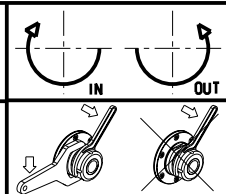

M.T. srl

Via Casino Albini 480
 Tel. 0541/956034-957884
 Fax 0541/956341

47842 S. GIOVANNI IN M. (RN)
 e-mail: mtma@mtmarchetti.com
 http://www.mtmarchetti.com



PAGINA MNZ150-1-20

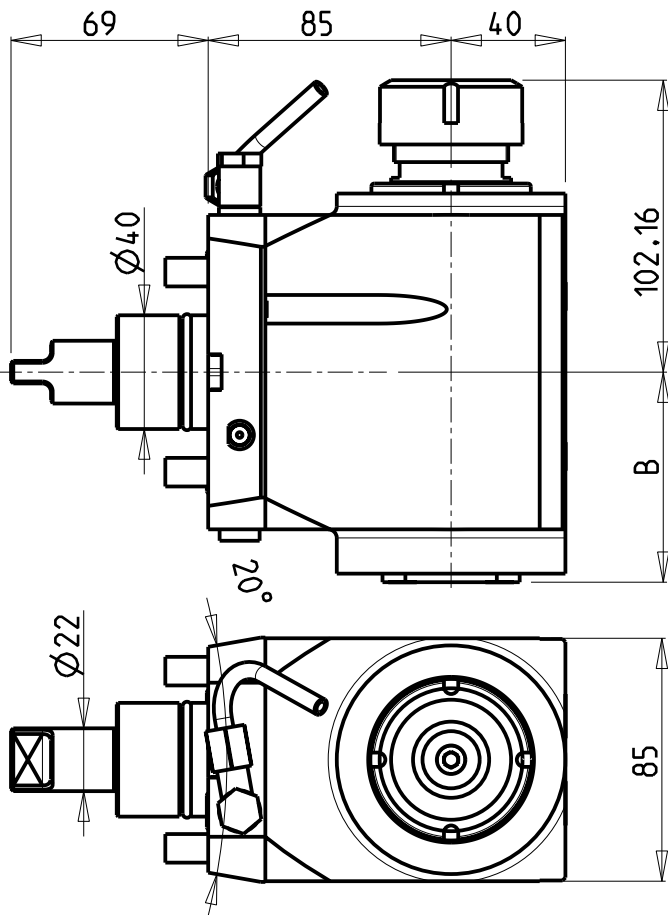

ATTENZIONE - ATTENTION - ACHTUNG

- Per lo smontaggio degli utensili utilizzare sempre la chiave di contrasto come indicato nel manuale d'uso.
- For disassembly of the tools use always the contrast key as mentioned in the user instructions.
- Fuer das Abmontieren der Werkzeuge immer den Gegenschlüssel benutzen wie in der Bedienungsanleitung erwäehnt.

ATTENZIONE - ATTENTION - ACHTUNG

- VERIFICARE LE MISURE DI INGOMBRO PER POSSIBILE INTERFERENZA SU ALCUNI MODELLI DI MACCHINE
- Please check the overall sizes for possible interferences on some machine models
- Bitte überprüfen sie das ausmass um mögliche interferenzen auf einigen maschinen modellen zu vermeiden

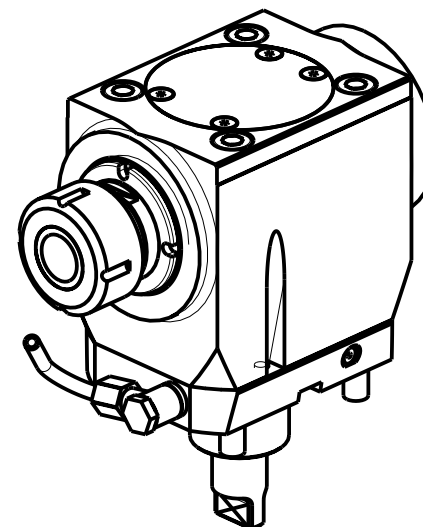

Cod. MT	Mandrino Spindle Spindel	I	RPM	Coppia Max Max Torque Max Drehmoment	Reversibile lato mandrino/contromandrino Reversible sub/main spindle side Umkehrbare Spindel-seite/ Gegenspindel-seite	Lubrificazione int. Coolant through Innenkuehlung	Lubrificazione est. Ext. coolant Aussenkuehlung	B	CHIAVI NON INCLUSE Keys not included Schluessel nicht einbegriffen	
MNZ0070132	ER32	2:1	3000	70Nm	X		X	73.5	CHUB36	CHSTER32
MNZ0070232	ER32	2:1	3000	70Nm	X	P=70bar	X	83.5	CHUB36	CHSTER32

DMG-MORI

NZ1500/2000 - NZX1500/2000 - NZX2500 (BMT40) - NT3100/3150/3200 - NL1500/2000/2500 20 STAZ. - NLX1500/2000/2500 20 STAZ. - NT1000/2000 NTX1000/2000 - NTX1000/2000/2500/3000 2ND GEN. 12ST. - DURATURN 2050MC/2550MC - NRX2000 - ALX1500/2000/2500 - ECOTURN 450 (BMT40)

MODULO MOTORIZZATO ASSIALE RIDOTTO I=2:1

Axial geared-down I=2:1 driven tool

Axial angetriebenes Werkzeug untersetzt I=2:1

Subject to change without notice.

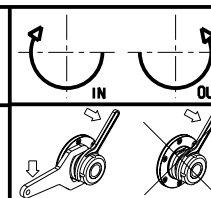

M.T. srl

Via Casino Albini 480
Tel. 0541/956034-957884
Fax 0541/956341
47842 S. GIOVANNI IN M. (RN)
e-mail: mtma@mtmarchetti.com
http://www.mtmarchetti.com



PAGINA MNZ190-1-10

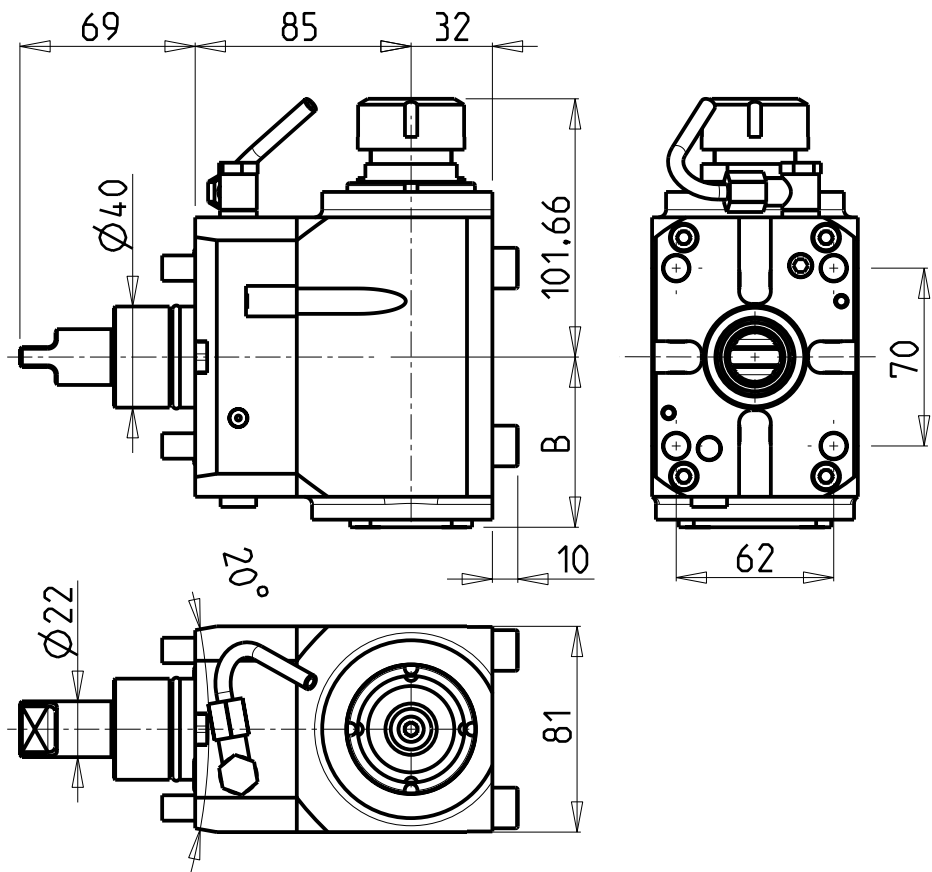

ATTENZIONE - ATTENTION - ACHTUNG

- VERIFICARE LE MISURE DI INGOMBRO PER POSSIBILE INTERFERENZA SU ALCUNI MODELLI DI MACCHINE
- Please check the overall sizes for possible interferences on some machine models
- Bitte überprüfen sie das ausmass um mögliche interferenzen auf einigen maschinen modellen zu vermeiden

ATTENZIONE - ATTENTION - ACHTUNG

- Per lo smontaggio degli utensili utilizzare sempre la chiave di contrasto come indicato nel manuale d'uso.
- For disassembly of the tools use always the contrast key as mentioned in the user instructions.
- Fuer das Abmontieren der Werkzeuge immer den Gegenschlüssel benutzen wie in der Bedienungsanleitung erwaeht.

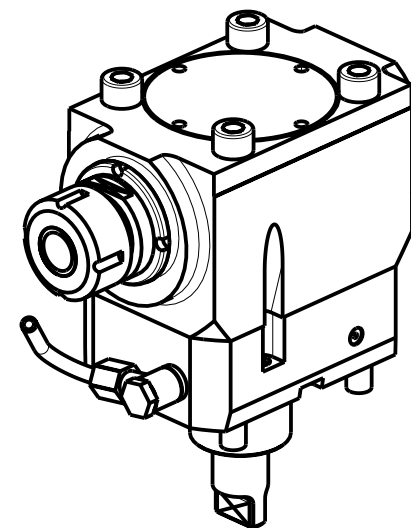

Cod. MT	Mandrino Spindle Spindel	I	RPM	Coppia Max Max Torque Max Drehmoment	Reversibile lato mandrino/controlmandrino Reversible sub/main spindle side Umkehrbare Spindel-seite/ Gegenspindel-seite	Lubrificazione int. Coolant through Innenkuehlung	Lubrificazione est. Ext. coolant Aussenkuehlung	B	CHIAVI NON INCLUSE Keys not included Schlüssel nicht einbegriffen	
MNZ0080125	ER25	1:2	12000	30Nm	X		X	67	CHUB36	CHSTER25
MNZ0080225	ER25	1:2	12000	30Nm	X	P=70bar	X	77	CHUB36	CHSTER25

DMG-MORI

NZ1500/2000 - NZX1500/2000 - NZX2500 (BMT40) - NT3100/3150/3200 - NL1500/2000/2500 20 STAZ. - NLX1500/2000/2500 20 STAZ. - NT1000/2000
NTX1000/2000 - NTX1000/2000/2500/3000 2ND GEN. 12ST. - DURATURN 2050MC/2550MC - NRX2000 - ALX1500/2000/2500 - ECOTURN 450 (BMT40)

MODULO MOTORIZZATO ASSIALE MOLTIPLICATO I=1:2 H=85mm

Axial geared-up I=1:2 driven tool H=85mm

Axial angetriebenes Werkzeug uebersetzt I=1:2 H=85mm

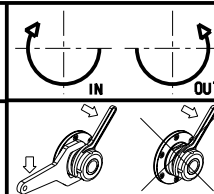

M.T. srl

Via Casino Albini 480
Tel. 0541/956034-957884
Fax 0541/956341
47842 S. GIOVANNI IN M. (RN)
e-mail: mtma@mtmarchetti.com
http://www.mtmarchetti.com



PAGINA MNZ200-1-10

Subject to change without notice.

10/2021

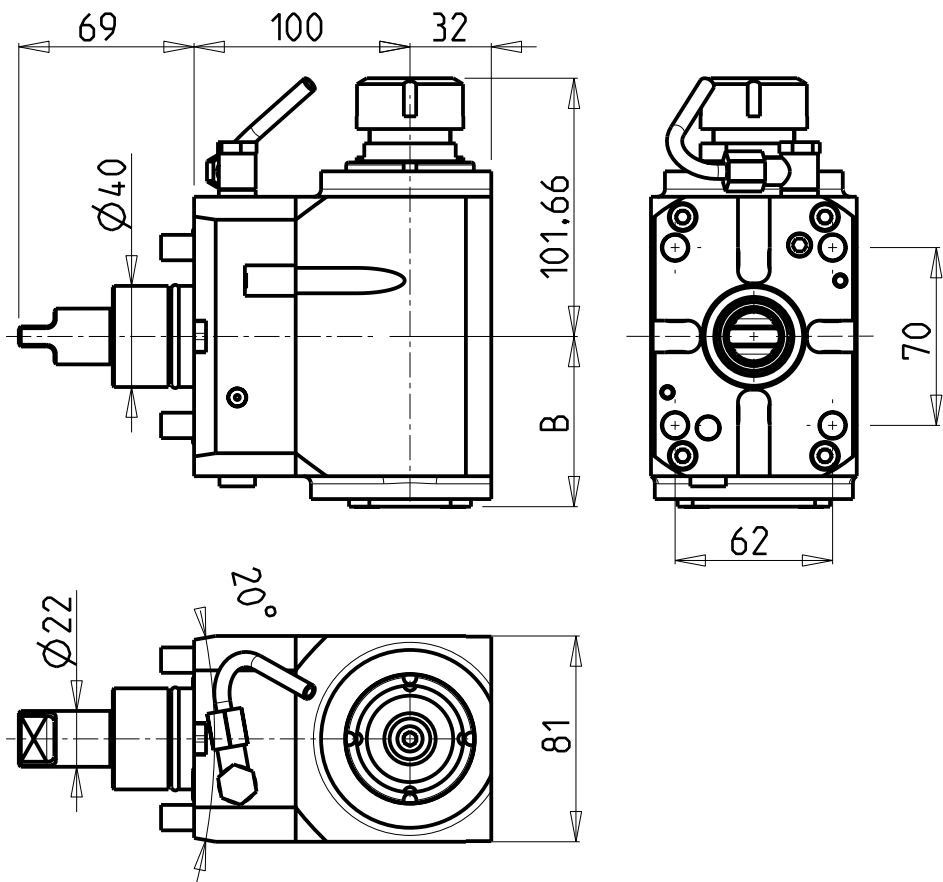

ATTENZIONE - ATTENTION - ACHTUNG

- VERIFICARE LE MISURE DI INGOMBRO PER POSSIBILE INTERFERENZA SU ALCUNI MODELLI DI MACCHINE
- Please check the overall sizes for possible interferences on some machine models
- Bitte überprüfen sie das ausmass um mögliche interferenzen auf einigen maschinen modellen zu vermeiden

ATTENZIONE - ATTENTION - ACHTUNG

- Per lo smontaggio degli utensili utilizzare sempre la chiave di contrasto come indicato nel manuale d'uso.
- For disassembly of the tools use always the contrast key as mentioned in the user instructions.
- Fuer das Abmontieren der Werkzeuge immer den Gegenschlüssel benutzen wie in der Bedienungsanleitung erwaeht.

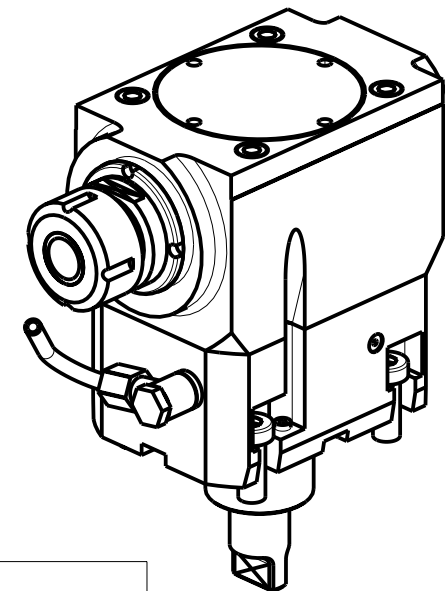

Cod. MT	Mandrino Spindle Spindel	I	RPM	Coppia Max Max Torque Max Drehmoment	Reversibile lato mandrino/contromandrino Reversible sub/main spindle side Umkehrbare Spindel-seite/ Gegenspindel-seite	Lubrificazione int. Coolant through Innenkuehlung	Lubrificazione est. Ext. coolant Aussenkuehlung	B	CHIAVI NON INCLUSE Keys not included Schlüssell nicht einbegriffen	
MNZ0081125	ER25	1:2	12000	30Nm	X		X	67	CHUB36	CHSTER25
MNZ0081225	ER25	1:2	12000	30Nm	X	P=70bar	X	77	CHUB36	CHSTER25

DMG-MORI

NZ1500/2000 - NZX1500/2000 - NT3100/3150/3200 - NL1500/2000/2500 20 STAZ. - NLX1500/2000/2500 20 STAZ.
 NT1000/2000 - NTX1000/2000 - NTX1000/2000/2500/3000 2ND GEN. 12ST. - DURATURN 2050MC/2550MC - ALX1500/2000/2500

MODULO MOTORIZZATO ASSIALE MOLTIPLICATO I=1:2 H=100mm

Axial geared-up I=1:2 driven tool H=100mm

Axial angetriebenes Werkzeug uebersetzt I=1:2 H=100mm

Subject to change without notice.

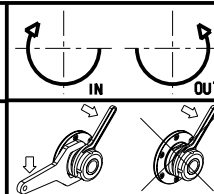

M.T. srl

Via Casino Albini 480
 Tel. 0541/956034-957884
 Fax 0541/956341
 47842 S. GIOVANNI IN M. (RN)
 e-mail: mtma@mtmarchetti.com
 http://www.mtmarchetti.com



PAGINA MNZ200-1-20

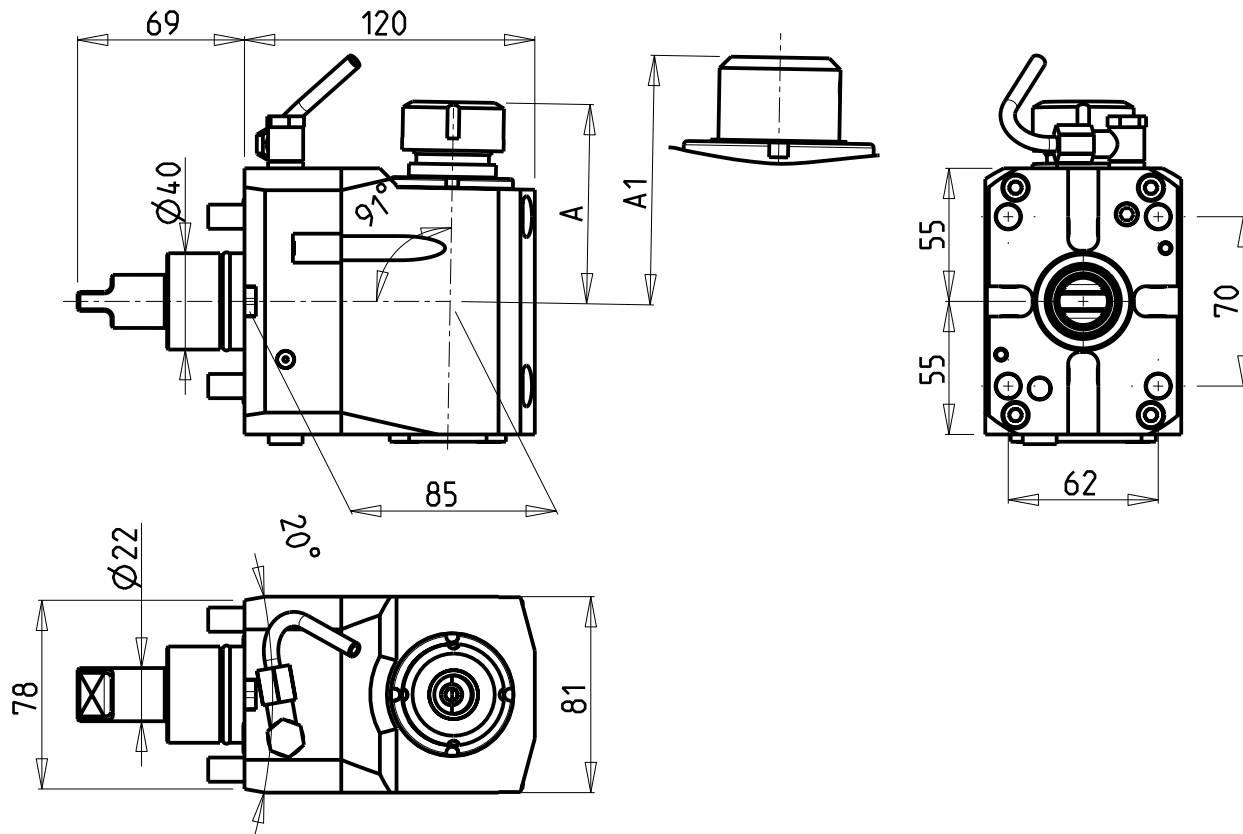

ATTENZIONE - ATTENTION - ACHTUNG

- Per lo smontaggio degli utensili utilizzare sempre la chiave di contrasto come indicato nel manuale d'uso.
- For disassembly of the tools use always the contrast key as mentioned in the user instructions.
- Fuer das Abmontieren der Werkzeuge immer den Gegenschlüssel benutzen wie in der Bedienungsanleitung erwaeht.

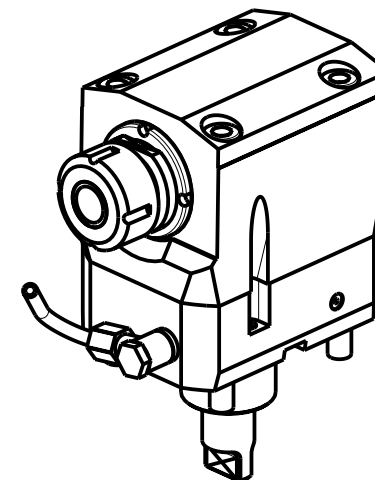

Cod. MT	Mandrino Spindle Spindel	I	RPM	Coppia Max Max Torque Max Drehmoment	Reversibile lato mandrino/contromandrino Reversible sub/main spindle side Umkehrbare Spindel-seite/ Gegenspindel-seite	Lubr.esterna Ext. coolant Aussenkuehlung	A	A1	CHIAVI NON INCLUSE Keys not included Schlüssel nicht einbegriffen	
									CHUB36	CHSTER25
MNZ0239125	ER25	1:1	6000	40Nm	X	X	82.36	-	CHUB36	CHSTER25
MNZ0239108	WELDON 8	1:1	6000	40Nm	X	X	-	76.5	-	-
MNZ0239110	WELDON 10	1:1	6000	40Nm	X	X	-	76.5	-	-
MNZ0239112	WELDON 12	1:1	6000	40Nm	X	X	-	76.5	-	-
MNZ0239116	WELDON 16	1:1	6000	40Nm	X	X	-	73.5	-	-

DMG-MORI

NZ1500/2000 - NZX1500/2000 - NZX2500 (BMT40) - NT3100/3150/3200 - NL1500/2000/2500 20 STAZ. - NLX1500/2000/2500 20 STAZ. - NT1000/2000
NTX1000/2000 - NTX1000/2000/2500/3000 2ND GEN. 12ST. - DURATURN 2050MC/2550MC - NRX2000 - ALX1500/2000/2500 - ECOTURN 450 (BMT40)

MODULO MOTORIZZATO ASSIALE PER POLIGONATURA INTERNA H=85mm

Axial driven tool for internal polygon-making H=85mm

Axial angetriebenes Werkzeug fuer interne Facettierung H=85 mm

Subject to change without notice.

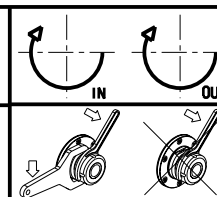

M.T. srl

Via Casino Albini 480
Tel. 0541/956034-957884
Fax 0541/956341
47842 S. GIOVANNI IN M. (RN)
e-mail: mtma@tmarchetti.com
http://www.mtmarchetti.com



PAGINA MNZ230-1-10

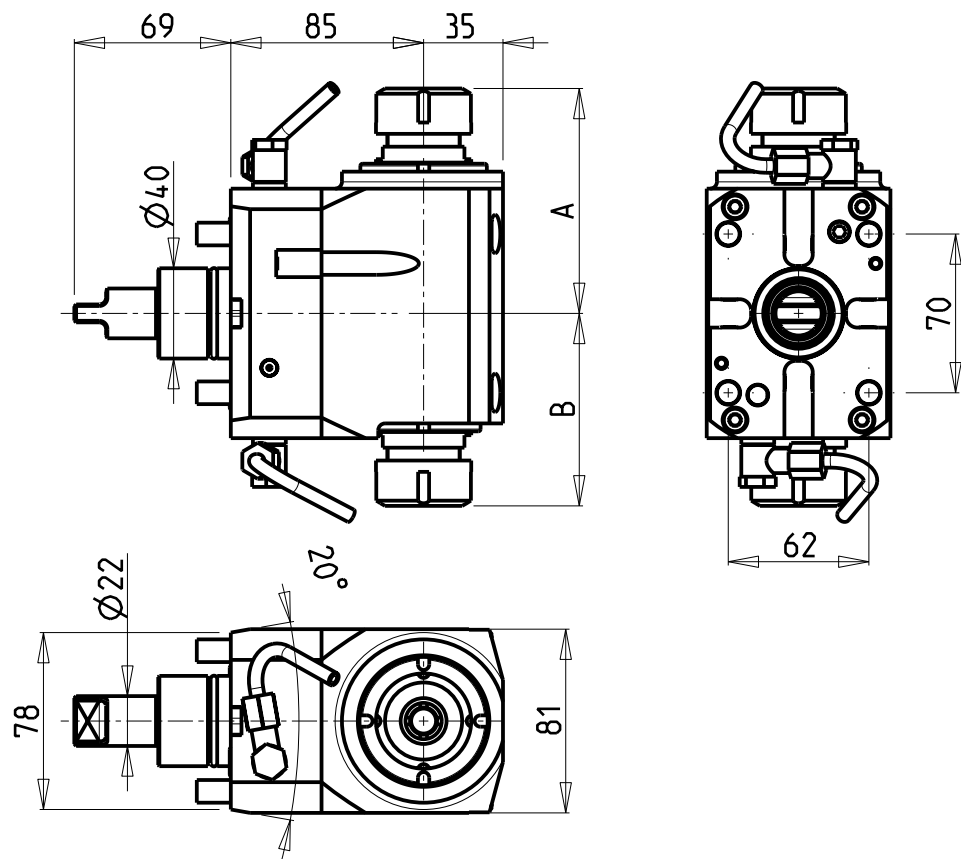

ATTENZIONE - ATTENTION - ACHTUNG

- VERIFICARE LE MISURE DI INGOMBRO PER POSSIBILE INTERFERENZA SU ALCUNI MODELLI DI MACCHINE
- Please check the overall sizes for possible interferences on some machine models
- Bitte überprüfen sie das ausmass um mögliche interferenzen auf einigen maschinen modellen zu vermeiden

ATTENZIONE - ATTENTION - ACHTUNG

- Per lo smontaggio degli utensili utilizzare sempre la chiave di contrasto come indicato nel manuale d'uso.
- For disassembly of the tools use always the contrast key as mentioned in the user instructions.
- Fuer das Abmontieren der Werkzeuge immer den Gegenschlüssel benutzen wie in der Bedienungsanleitung erwaeht.

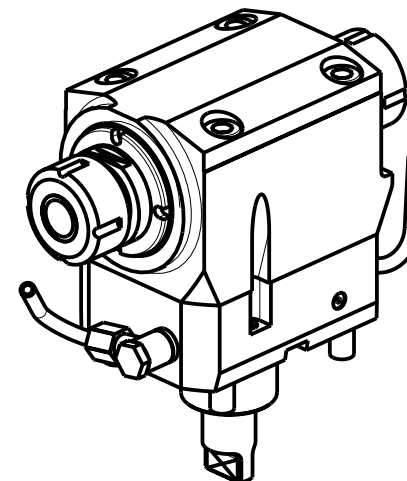

Cod. MT	Cod. MORI-SEIKI	Mandrino Spindle Spindel	I	RPM	Coppia Max Max Torque Max Drehmoment	Reversibile lato mandrino/contromandrino Reversible sub/main spindle side Umkehrbare Spindelseite/ Gegenspindelseite	Lubr.esterna Ext. coolant Aussenkuehlung	A	B	CHIAVI NON INCLUSE Keys not included Schlüssel nicht einbegriffen	
MNZ0010325	T32276	ER25+ER25	1:1	6000	40Nm	X	X	85.16	99.16	CHUB36	CHSTER25
MNZ0010332	-	ER32+ER32	1:1	6000	40Nm	X	X	88.16	102.16	CHUB36	CHSTER32

DMG-MORI

NZ1500/2000 - NZX1500/2000 - NT3100/3150/3200 - NL1500/2000/2500 20 STAZ. - NLX1500/2000/2500 20 STAZ.
NT1000/2000 - NTX1000/2000 - DURATURN 2050MC/2550MC - ALX1500/2000/2500 - ECOTURN 450 (BMT40)

MODULO MOTORIZZATO ASSIALE BISPORGENTE H=85mm

Axial opposite face twin driven tool H=85mm

Axial angetriebenes Werkzeug halb vorspringend H=85mm

Subject to change without notice.

M.T. srl

Via Casino Albini 480
Tel. 0541/956034-957884
Fax 0541/956341
47842 S. GIOVANNI IN M. (RN)
e-mail: mtma@mtmarchetti.com
http://www.mtmarchetti.com



PAGINA MNZ240-1-10

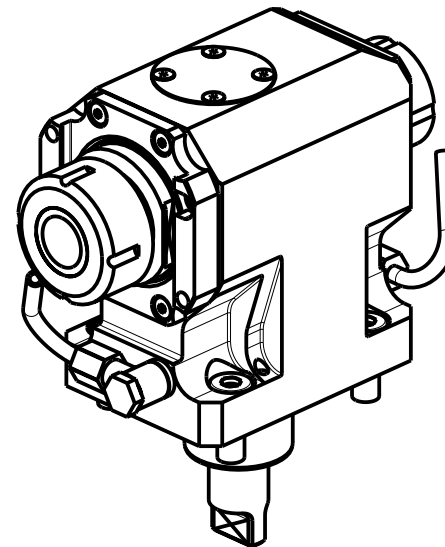
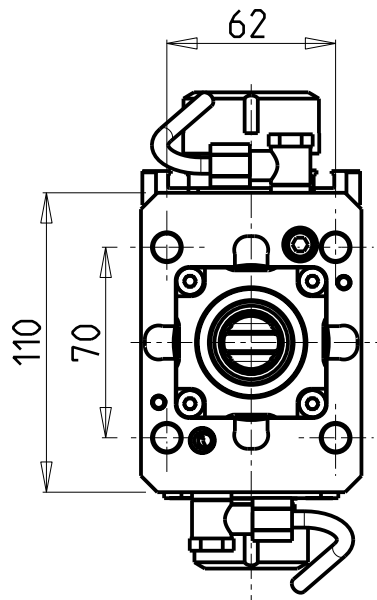
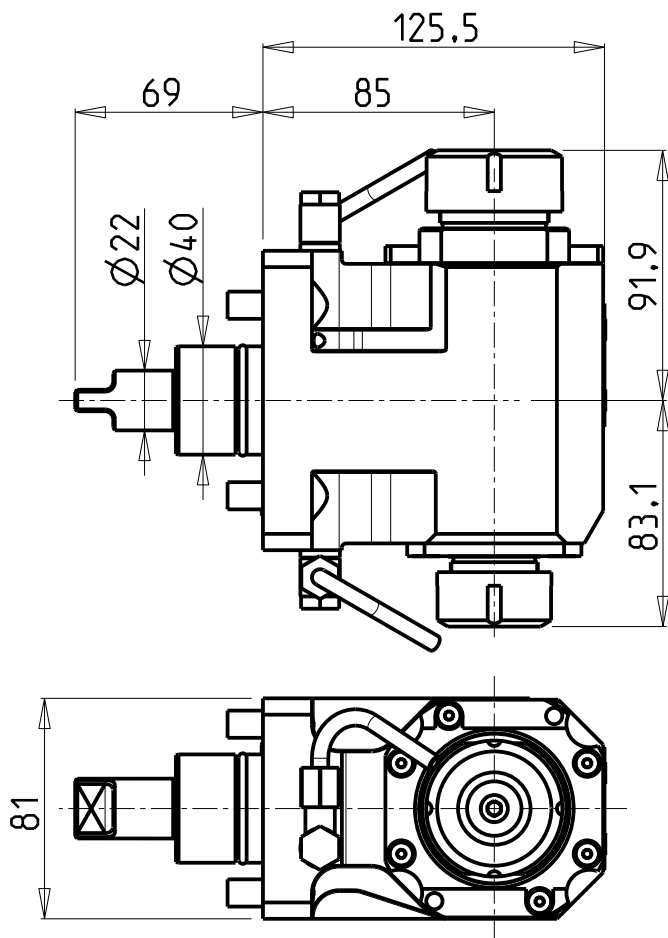

ATTENZIONE - ATTENTION - ACHTUNG

- Per lo smontaggio degli utensili utilizzare sempre la chiave di contrasto come indicato nel manuale d'uso.
- For disassembly of the tools use always the contrast key as mentioned in the user instructions.
- Fuer das Abmontieren der Werkzeuge immer den Gegenschlüssel benutzen wie in der Bedienungsanleitung erwaeht.

- Chiave inclusa
- Key included
- Schlüssel inbegriffen

Cod. MT	Mandrino Spindle Spindel	I	RPM	Coppia Max Max Torque Max Drehmoment	Reversibile lato mandrino/contromandrino Reversible sub/main spindle side Umkehrbare Spindel-seite/ Gegenspindel-seite	Lubr.esterna Ext. coolant Aussenkuehlung	CHIAVI NON INCLUDE Keys not included Schlüssel nicht einbegriffen		
MNZ0493225	ER32+ER25	1:1	12000	40Nm	X	X	CHSTER32	CHSTER25	MNZ0410005 •

DMG-MORI

NZ1500/2000 - NZX1500/2000 - NL1500/2000/2500 20 STAZ. - NLX1500/2000/2500 20 STAZ. - NTX1000/2000 - ALX1500/2000/2500

MODULO MOTORIZZATO ASSIALE BISPORGENTE 12000 RPM

Axial opposite face twin driven tool 12000 rpm

Axial angetriebenes Werkzeug halb vorspringend 12000 rpm

Subject to change without notice.

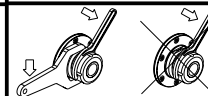

M.T. srl

Via Casino Albini 480
Tel. 0541/956034-957884
Fax 0541/956341
47842 S. GIOVANNI IN M. (RN)
e-mail: mtma@mtmarchetti.com
http://www.mtmarchetti.com



PAGINA MNZ240-1-11

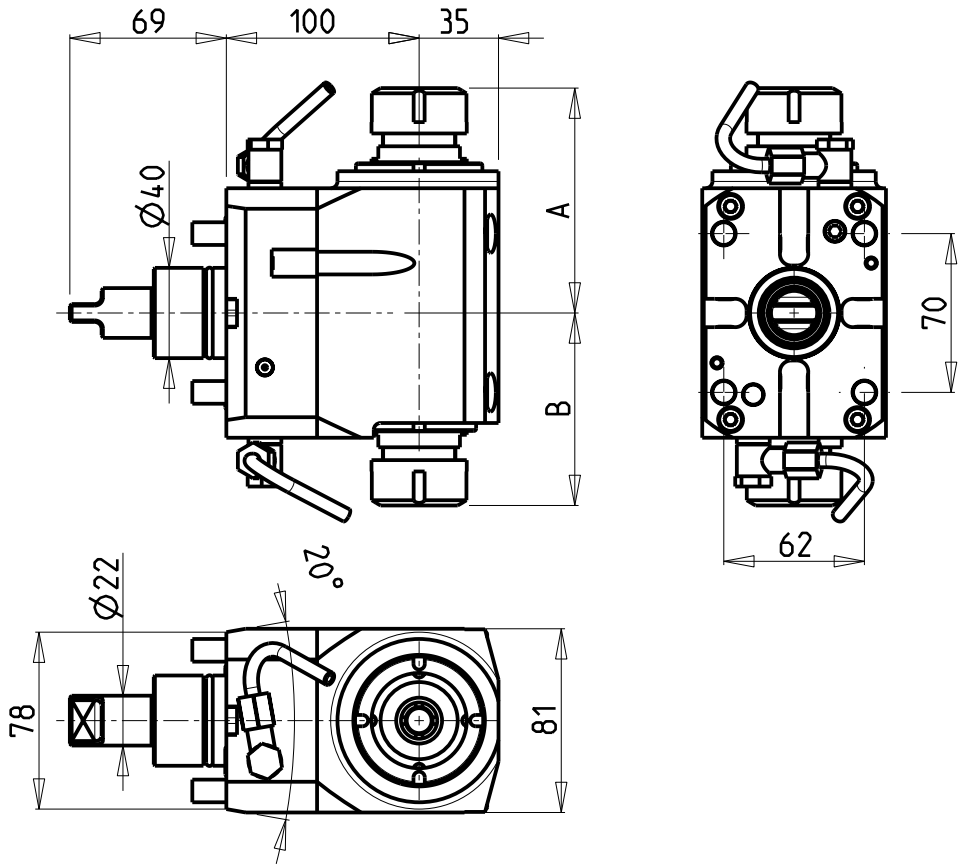

ATTENZIONE - ATTENTION - ACHTUNG

- VERIFICARE LE MISURE DI INGOMBRO PER POSSIBILE INTERFERENZA SU ALCUNI MODELLI DI MACCHINE
- Please check the overall sizes for possible interferences on some machine models
- Bitte überprüfen sie das ausmass um mögliche interferenzen auf einigen maschinen modellen zu vermeiden

ATTENZIONE - ATTENTION - ACHTUNG

- Per lo smontaggio degli utensili utilizzare sempre la chiave di contrasto come indicato nel manuale d'uso.
- For disassembly of the tools use always the contrast key as mentioned in the user instructions.
- Fuer das Abmontieren der Werkzeuge immer den Gegenschlüssel benutzen wie in der Bedienungsanleitung erwaeht.

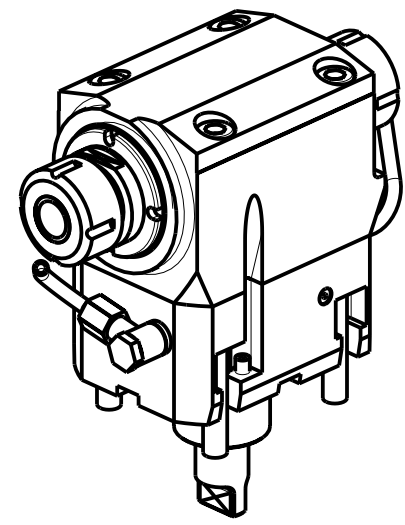

Cod. MT	Cod. MORI-SEIKI	Mandrino Spindle Spindel	I	RPM	Coppia Max Max Torque Max Drehmoment	Reversibile lato mandrino/contromandrino Reversible sub/main spindle side Umkehrbare Spindelsete/Gegenspindelsete	Lubr.esterna Ext. coolant Aussenkuehlung	A	B	CHIAVI NON INCLUSE Keys not included Schluessel nicht einbegriffen	
MNZ0210325	-	ER25+ER25	1:1	6000	40Nm	X	X	85.16	99.16	CHUB36	CHSTER25
MNZ0210332	-	ER32+ER32	1:1	6000	40Nm	X	X	88.16	102.16	CHUB36	CHSTER32

DMG-MORI

NZ1500/2000 - NZX1500/2000 - NT3100/3150/3200 - NL1500/2000/2500 20 STAZ. - NLX1500/2000/2500 20 STAZ.
 NT1000/2000 - NTX1000/2000 - DURATURN 2050MC /2550MC - ALX1500/2000/2500

MODULO MOTORIZZATO ASSIALE BISPORGENTE H=100mm

Axial opposite face twin driven tool H=100mm

Axial angetriebenes Werkzeug halb vorspringend H=100mm

Subject to change without notice.

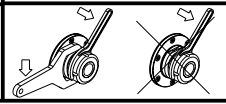

M.T. srl
 Via Casino Albini 480
 Tel. 0541/956034-957884
 Fax 0541/956341
 47842 S. GIOVANNI IN M. (RN)
 e-mail: mtma@mtmarchetti.com
 http://www.mtmarchetti.com



PAGINA MNZ240-1-20

ATTENZIONE - ATTENTION - ACHTUNG

- VERIFICARE LE MISURE DI INGOMBRO PER POSSIBILE INTERFERENZA SU ALCUNI MODELLI DI MACCHINE
- Please check the overall sizes for possible interferences on some machine models
- Bitte überprüfen sie das ausmass um mögliche interferenzen auf einigen maschinen modellen zu vermeiden

ATTENZIONE - ATTENTION - ACHTUNG

- Per lo smontaggio degli utensili utilizzare sempre la chiave di contrasto come indicato nel manuale d'uso.
- For disassembly of the tools use always the contrast key as mentioned in the user instructions.
- Fuer das Abmontieren der Werkzeuge immer den Gegenschlüssel benutzen wie in der Bedienungsanleitung erwäehnt.

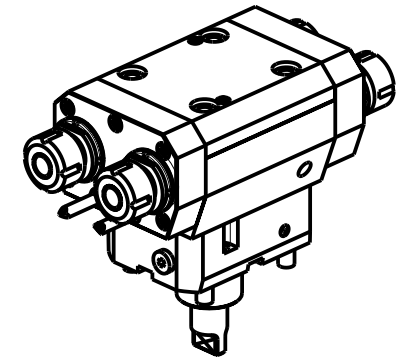
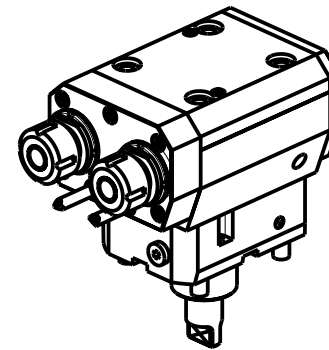
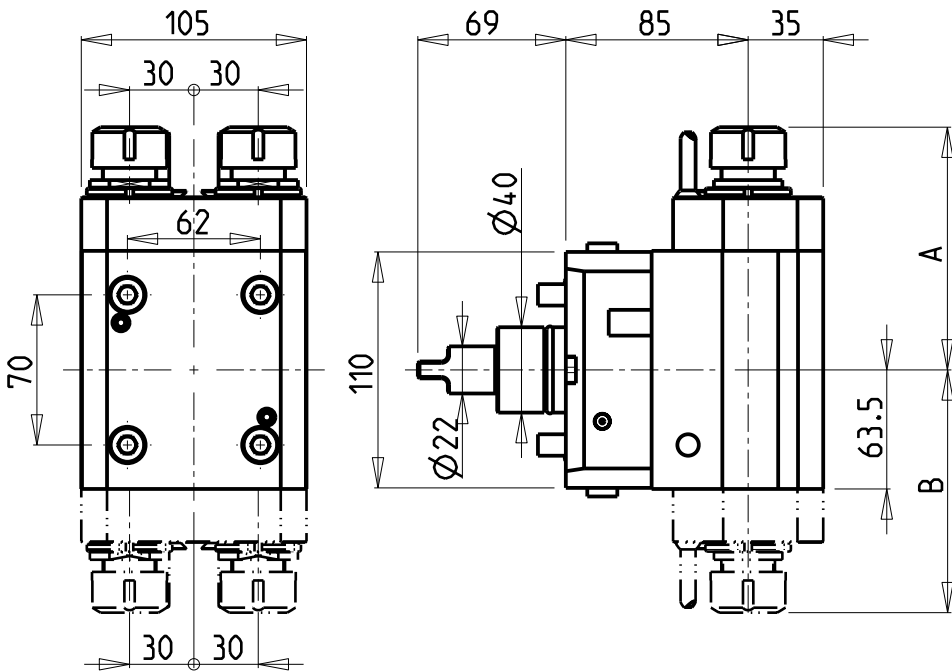

Cod. MT	Mandrino Spindle Spindel	I	RPM	Coppia Max Max Torque Max Drehmoment	N°Utensili N°Tools N°Werkzeuge	Reversibile lato mandrino/contromandrino Reversible sub/main spindle side Umkehrbare Spindel-seite/ Gegenspindel-seite	Lubr.esterna Ext. coolant Aussenkuehlung	A	B	CHIAVI NON INCLUDE Keys not included Schluessel nicht einbegriffen	
										CHUB32	CHUB19_SP3
MNZ0040316	ERA16	1:1	6000	40Nm	2	X	X	96.63	-	CHUB32	CHUB19_SP3
MNZ0040320	ER20	1:1	6000	40Nm	2	X	X	113.16	-	CHUB32	CHSTER20
MNZ0040416	ERA16+ERA16	1:1	6000	40Nm	2+2	X	X	96.63	96.63	CHUB32	CHUB19_SP3
MNZ0040420	ER20+ER20	1:1	6000	40Nm	2+2	X	X	113.16	113.16	CHUB32	CHSTER20

DMG-MORI

NZ1500/2000 - NZX1500/2000 - NT3100/3150/3200 - NL1500/2000/2500 20 STAZ. - NLX1500/2000/2500 20 STAZ.
 NT1000/2000 - DURATURN 2050MC/2550MC - ALX1500/2000/2500 - ECOTURN 450 (BMT40)

MODULO MOTORIZZATO ASSIALE 2/4 USCITE IN Y H=85mm

Axial multiple 2/4 outlet driven tool in Y H=85mm

Axial angetriebenes Mehrspindel-Werkzeug 2/4 Ausgaenge in Y H=85mm

Subject to change without notice.

M.T. srl

Via Casino Albini 480
 Tel. 0541/956034-957884
 Fax 0541/956341
 47842 S. GIOVANNI IN M. (RN)
 e-mail: mtma@mtmarchetti.com
 http://www.mtmarchetti.com

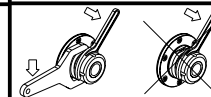

PAGINA MNZ268-1-00

ATTENZIONE - ATTENTION - ACHTUNG

- VERIFICARE LE MISURE DI INGOMBRO PER POSSIBILE INTERFERENZA SU ALCUNI MODELLI DI MACCHINE
- Please check the overall sizes for possible interferences on some machine models
- Bitte überprüfen sie das ausmass um mögliche interferenzen auf einigen maschinen modellen zu vermeiden

ATTENZIONE - ATTENTION - ACHTUNG

- Per lo smontaggio degli utensili utilizzare sempre la chiave di contrasto come indicato nel manuale d'uso.
- For disassembly of the tools use always the contrast key as mentioned in the user instructions.
- Fuer das Abmontieren der Werkzeuge immer den Gegenschlüssel benutzen wie in der Bedienungsanleitung erwaeht.

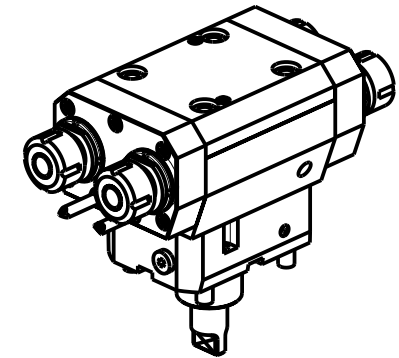
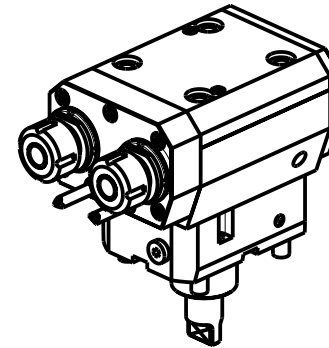
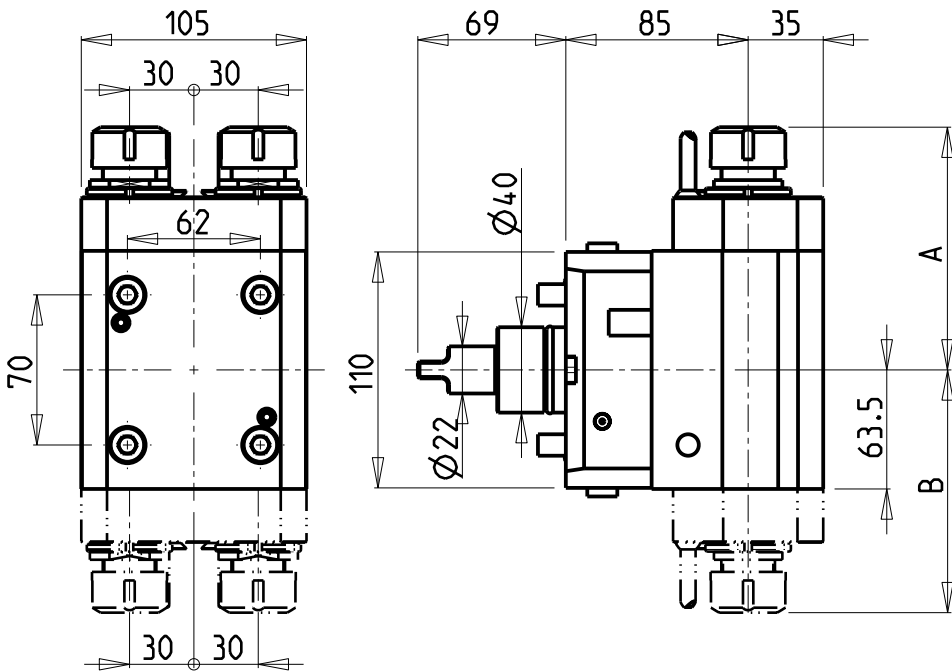

Cod. MT	Mandrino Spindle Spindel	I	RPM	Coppia Max Max Torque Max Drehmoment	N°Utensili N°Tools N°Werkzeuge	Reversibile lato mandrino/contromandrino Reversible sub/main spindle side Umkehrbare Spindelseite/ Gegenspindelseite	Lubr.esterna Ext. coolant Aussenkuehlung	A	B	CHIAVI NON INCLUDE Keys not included Schluessel nicht einbegriffen	
MNZ0610316	ERA16	1:1	12000	40Nm	2	X	X	96.63	-	CHUB32	CHUB19_SP3
MNZ0610320	ER20	1:1	12000	40Nm	2	X	X	113.16	-	CHUB32	CHSTER20
MNZ0610416	ERA16+ERA16	1:1	12000	40Nm	2+2	X	X	96.63	96.63	CHUB32	CHUB19_SP3
MNZ0610420	ER20+ER20	1:1	12000	40Nm	2+2	X	X	113.16	113.16	CHUB32	CHSTER20

DMG-MORI

NZ1500/2000 - NZX1500/2000 - NL1500/2000/2500 20 STAZ. - NLX1500/2000/2500 20 STAZ. - NTX1000/2000 - ALX1500/2000/2500

MODULO MOTORIZZATO ASSIALE 2/4 USCITE IN Y 12000 RPM H=85mm

Axial multiple 2/4 outlet driven tool in Y 12000 rpm H=85mm

Axial angetriebenes Mehrspindel-Werkzeug 2/4 Ausgaenge in Y 12000 rpm H=85mm

Subject to change without notice.

M.T. srl

Via Casino Albini 480
Tel. 0541/956034-957884
Fax 0541/956341
47842 S. GIOVANNI IN M. (RN)
e-mail: mtma@tmarchetti.com
http://www.mtmarchetti.com



PAGINA MNZ268-1-01

ATTENZIONE - ATTENTION - ACHTUNG

- VERIFICARE LE MISURE DI INGOMBRO PER POSSIBILE INTERFERENZA SU ALCUNI MODELLI DI MACCHINE
- Please check the overall sizes for possible interferences on some machine models
- Bitte überprüfen sie das ausmass um mögliche interferenzen auf einigen maschinen modellen zu vermeiden

ATTENZIONE - ATTENTION - ACHTUNG

- Per lo smontaggio degli utensili utilizzare sempre la chiave di contrasto come indicato nel manuale d'uso.
- For disassembly of the tools use always the contrast key as mentioned in the user instructions.
- Fuer das Abmontieren der Werkzeuge immer den Gegenschlüssel benutzen wie in der Bedienungsanleitung erwaeht.

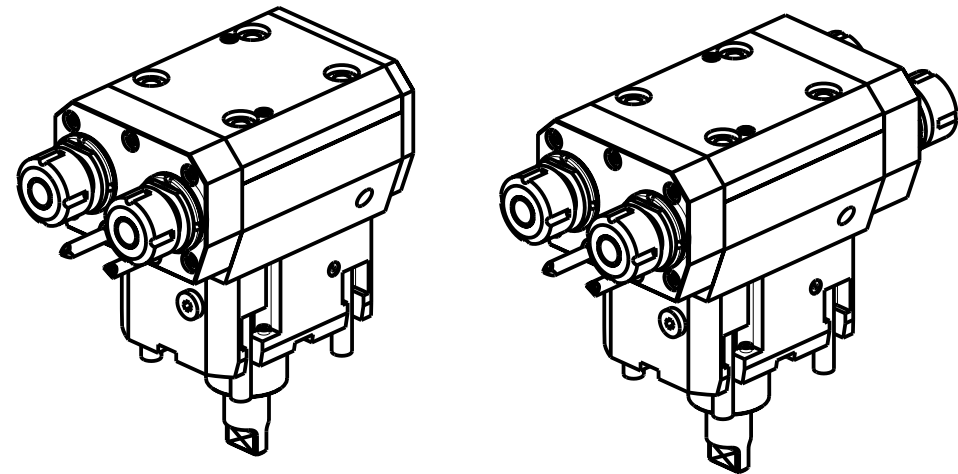
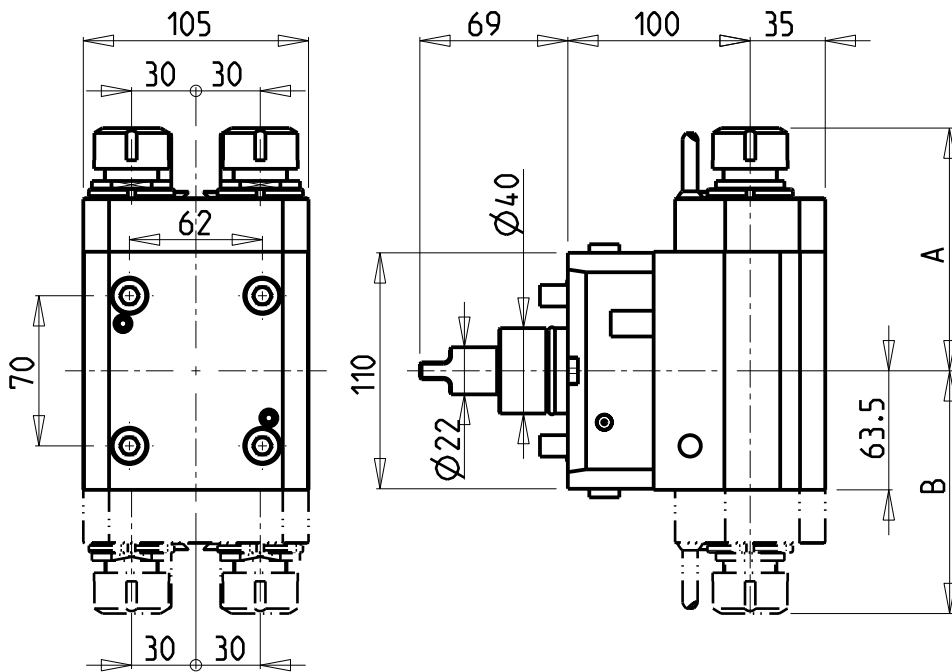

Cod. MT	Mandrino Spindle Spindel	I	RPM	Coppia Max Max Torque Max Drehmoment	N°Utensili N°Tools N°Werkzeuge	Reversibile lato mandrino/contromandrino Reversible sub/main spindle side Umkehrbare Spindelseite/ Gegenspindelseite	Lubr.esterna Ext. coolant Aussenkuehlung	A	B	CHIAVI NON INCLUSE Keys not included Schluessel nicht einbegriffen	
MNZ0041316	ERA16	1:1	6000	40Nm	2	X	X	96.63	-	CHUB32	CHUB19_SP3
MNZ0041320	ER20	1:1	6000	40Nm	2	X	X	113.16	-	CHUB32	CHSTER20
MNZ0041416	ERA16+ERA16	1:1	6000	40Nm	2+2	X	X	96.63	96.63	CHUB32	CHUB19_SP3
MNZ0041420	ER20+ER20	1:1	6000	40Nm	2+2	X	X	113.16	113.16	CHUB32	CHSTER20

DMG-MORI

NZ1500/2000 - NZX1500/2000 - NT3100/3150/3200 - NL1500/2000/2500 20 STAZ. - NLX1500/2000/2500 20 STAZ.
 NT1000/2000 - DURATURN 2050MC/2550MC - ALX1500/2000/2500

MODULO MOTORIZZATO ASSIALE 2/4 USCITE IN Y H=100mm

Axial multiple 2/4 outlet driven tool in Y H=100mm

Axial angetriebenes Mehrspindel-Werkzeug 2/4 Ausgaenge in Y H=100mm

Subject to change without notice.

M.T. srl

Via Casino Albini 480
 Tel. 0541/956034-957884
 Fax 0541/956341
 47842 S. GIOVANNI IN M. (RN)
 e-mail: mtma@mtmarchetti.com
 http://www.mtmarchetti.com



PAGINA MNZ268-1-10

ATTENZIONE - ATTENTION - ACHTUNG

- VERIFICARE LE MISURE DI INGOMBRO PER POSSIBILE INTERFERENZA SU ALCUNI MODELLI DI MACCHINE
- Please check the overall sizes for possible interferences on some machine models
- Bitte überprüfen sie das ausmass um mögliche interferenzen auf einigen maschinen modellen zu vermeiden

ATTENZIONE - ATTENTION - ACHTUNG

- Per lo smontaggio degli utensili utilizzare sempre la chiave di contrasto come indicato nel manuale d'uso.
- For disassembly of the tools use always the contrast key as mentioned in the user instructions.
- Fuer das Abmontieren der Werkzeuge immer den Gegenschlüssel benutzen wie in der Bedienungsanleitung erwaeht.

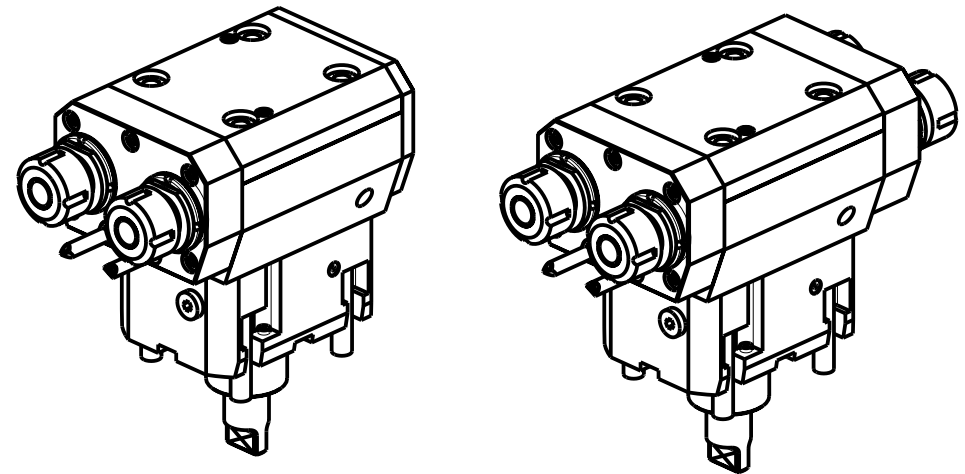
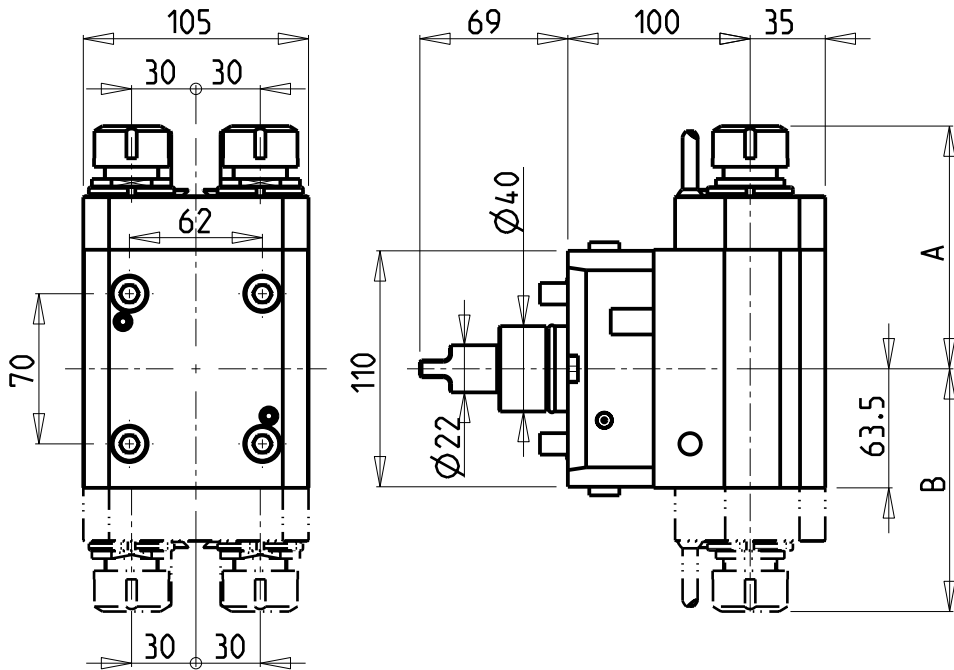

Cod. MT	Mandrino Spindle Spindel	I	RPM	Coppia Max Max Torque Max Drehmoment	N°Utensili N°Tools N°Werkzeuge	Reversibile lato mandrino/contromandrino Reversible sub/main spindle side Umkehrbare Spindel-seite/ Gegenspindel-seite	Lubr.esterna Ext. coolant Aussenkuehlung	A	B	CHIAVI NON INCLUSE Keys not included Schluessel nicht einbegriffen	
MNZ0611316	ERA16	1:1	12000	40Nm	2	X	X	96.63	-	CHUB32	CHUB19_SP3
MNZ0611320	ER20	1:1	12000	40Nm	2	X	X	113.16	-	CHUB32	CHSTER20
MNZ0611416	ERA16+ERA16	1:1	12000	40Nm	2+2	X	X	96.63	96.63	CHUB32	CHUB19_SP3
MNZ0611420	ER20+ER20	1:1	12000	40Nm	2+2	X	X	113.16	113.16	CHUB32	CHSTER20

DMG-MORI

NZ1500/2000 - NZX1500/2000 - NL1500/2000/2500 20 STAZ. - NLX1500/2000/2500 20 STAZ. - NTX1000/2000 - ALX1500/2000/2500

MODULO MOTORIZZATO ASSIALE 2/4 USCITE IN Y 12000 RPM H=100mm

Axial multiple 2/4 outlet driven tool in Y 12000 rpm H=100mm

Axial angetriebenes Mehrspindel-Werkzeug 2/4 Ausgaenge in Y 12000 rpm H=100mm

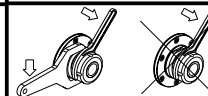

M.T. srl

Via Casino Albini 480
Tel. 0541/956034-957884
Fax 0541/956341
47842 S. GIOVANNI IN M. (RN)
e-mail: mtma@mtmarchetti.com
http://www.mtmarchetti.com



PAGINA MNZ268-1-11

Subject to change without notice.

10/2021

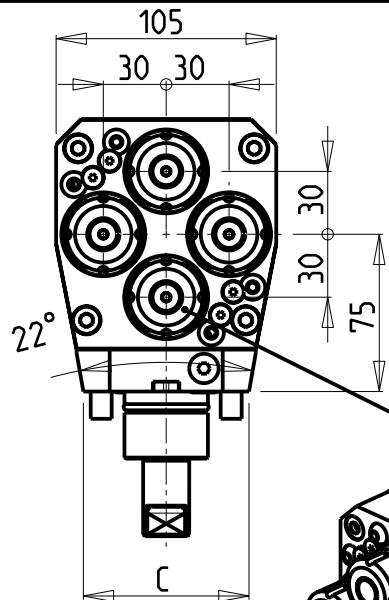
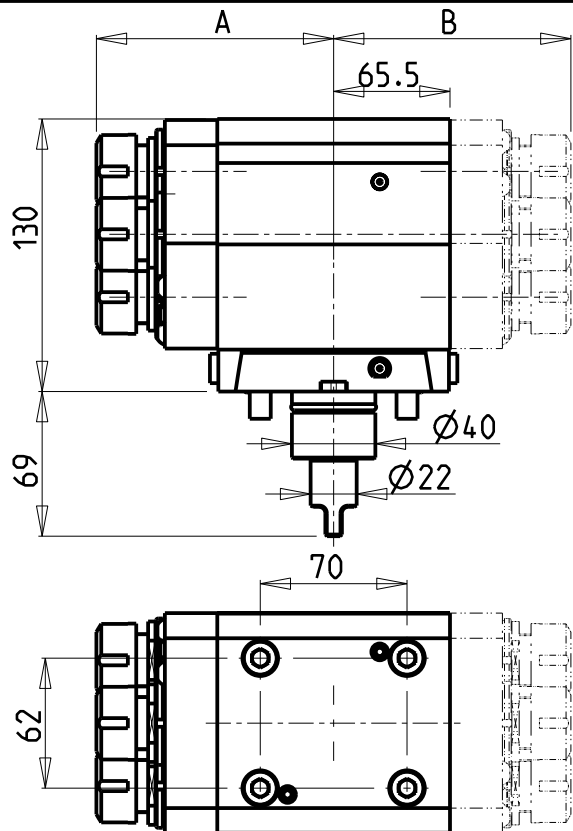

ATTENZIONE - ATTENTION - ACHTUNG

- Su macchine NZ1500/2000 - NZX1500/2000 - NT3000 SERIE non arriva in centro mandrino.
- On machines NZ1500/2000 - NZX1500/2000 - NT3000 SERIE tool does not get to the centre of the spindle axis.
- Auf Maschinen NZ1500/2000 - NZX1500/2000 - NT3000 SERIE erreicht das Werkzeug nicht die Mitte der Werkzeug-Achse.

ATTENZIONE - ATTENTION - ACHTUNG

- VERIFICARE LE MISURE DI INGOMBRO PER POSSIBILE INTERFERENZA SU ALCUNI MODELLI DI MACCHINE
- Please check the overall sizes for possible interferences on some machine models
- Bitte überprüfen sie das ausmass um mögliche interferenzen auf einigen maschinen modellen zu vermeiden

MNZ0670416

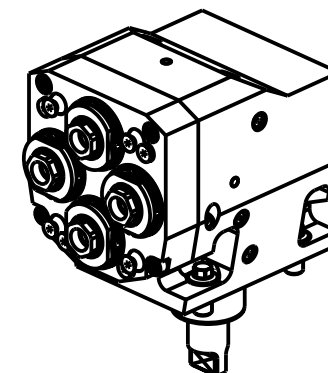
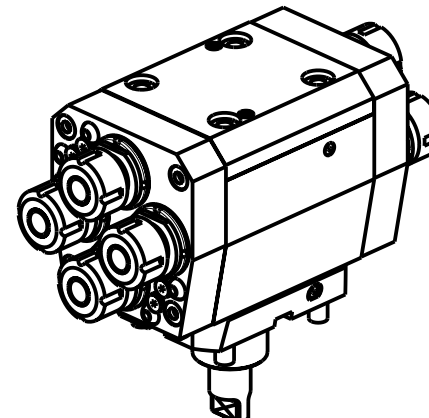
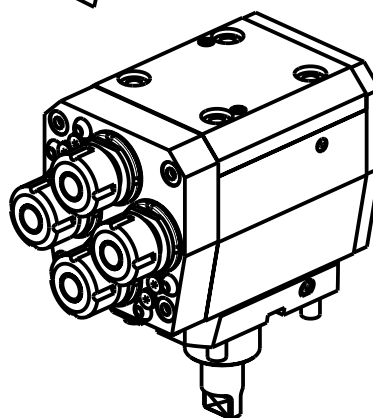

Cod. MT	Mandrino Spindle Spindel	I	RPM	Coppia Max Torque Max Drehmoment	N°Utensili N°Tools N°Werkzeuge	Reversibile lato mandrino/contromandrino Reversible sub/main spindle side Umkehrbare Spindel-seite/ Gegenspindel-seite	Lubr.interna Coolant through Innenkuehlung	Lubr.esterna Ext. coolant Aussenkuehlung	A	B	C	CHIAVI INCLUDE Keys included Schluessel einbegriffen	
MNZ0040116	ERA16	1:1	6000	30Nm	4	X	-	X	96.63	-	79	CHUB32	CHUB19_SP3
MNZ0670416	ERA16	1:1	6000	30Nm	4	X	P=70bar	X	99.07	-	82	CHUB32	CHUB19_SP3
MNZ0040120	ER20	1:1	6000	30Nm	4	X	-	X	113.16	-	79	CHUB32	CHSTER20
MNZ0040216	ERA16+ERA16	1:1	6000	30Nm	4+4	X	-	X	96.63	96.63	79	CHUB32	CHUB19_SP3
MNZ0040220	ER20+ER20	1:1	6000	30Nm	4+4	X	-	X	113.16	113.16	79	CHUB32	CHSTER20

DMG-MORI

NZ1500/2000 - NZX1500/2000 - NT3100/3150/3200 - NL1500/2000/2500 20 STAZ. - NLX1500/2000/2500 20 STAZ.
DURATURN 2050MC/2550MC - ECOTURN 450 (BMT40)

MODULO MOTORIZZATO ASSIALE 4/8 USCITE

Axial multiple 4/8 outlet driven tool

Axial angetriebenes Mehrspindel-Werkzeug 4/8 Ausgaenge

Subject to change without notice.

M.T. srl

Via Casino Albini 480
Tel. 0541/956034-957884
Fax 0541/956341

47842 S. GIOVANNI IN M. (RN)
e-mail: mtma@mtmarchetti.com
http://www.mtmarchetti.com



PAGINA MNZ270-1-00

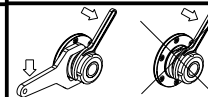

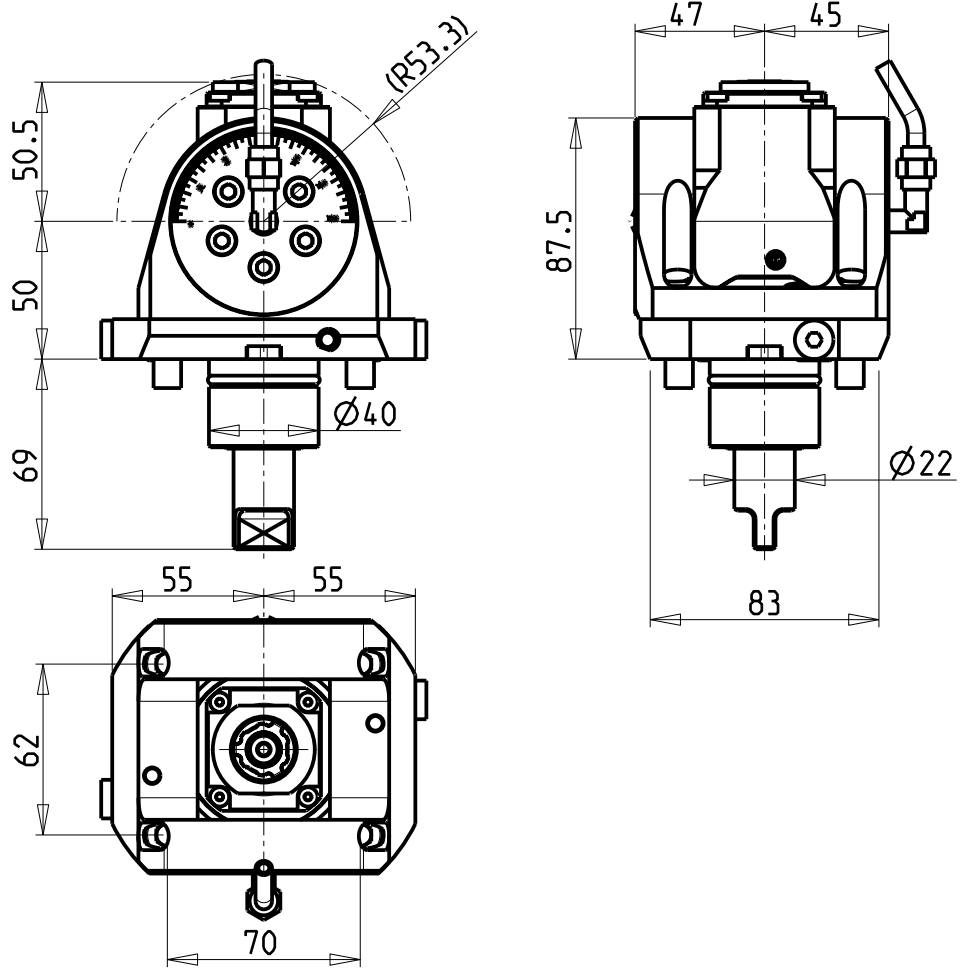

ATTENZIONE - ATTENTION - ACHTUNG

- Per lo smontaggio degli utensili utilizzare sempre la chiave di contrasto come indicato nel manuale d'uso.
- For disassembly of the tools use always the contrast key as mentioned in the user instructions.
- Fuer das Abmontieren der Werkzeuge immer den Gegenschlüssel benutzen wie in der Bedienungsanleitung erwäehnt.

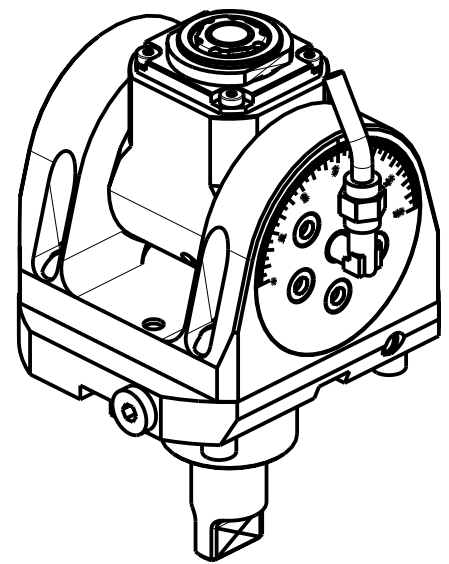

Cod. MT	Mandrino Spindle Spindel	I	RPM	Coppia Max Max Torque Max Drehmoment	Lubrificazione int. Coolant through Innenkuehlung	Lubrificazione est. Ext. coolant Aussenkuehlung	CHIAVI INCLUSE Keys included Schluesssel inbegriffen			
							CHUB36	CHUB22	CHESLO8	CHTAER20ZC
MNZ0390120	ER A 20	1:1	6000	30Nm		X	CHUB36	CHUB22	CHESLO8	CHTAER20ZC
MNZ0390220	ER A 20	1:1	6000	30Nm	P=70bar	X	CHUB36	CHUB22	CHESLO8	CHTAER20ZC

DMG-MORI
 NZ1500/2000 - NZX1500/2000 - NZX2500 (BMT40) - NT3100/3150/3200 - NT1000/2000 - NTX1000/2000 - NTX1000/2000/2500/3000 2ND GEN. 12ST.
 DURATURN 2050MC/2550MC - NRX2000 - ALX1500/2000/2500 - ECOTURN 450 (BMT40)

MODULO MOTORIZZATO ORIENTABILE +/-90° H=50mm
 +/-90° adjustable angle driven tool H=50mm
 Angetriebenes Werkzeug schwenkbar +/-90° H=50mm

Subject to change without notice.

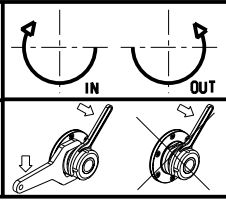

M.T. srl
 Via Casino Albini 480
 Tel. 0541/956034-957884
 Fax 0541/956341
 47842 S. GIOVANNI IN M. (RN)
 e-mail: mtma@mtmarchetti.com
 http://www.mtmarchetti.com



PAGINA MNZ335-1-00

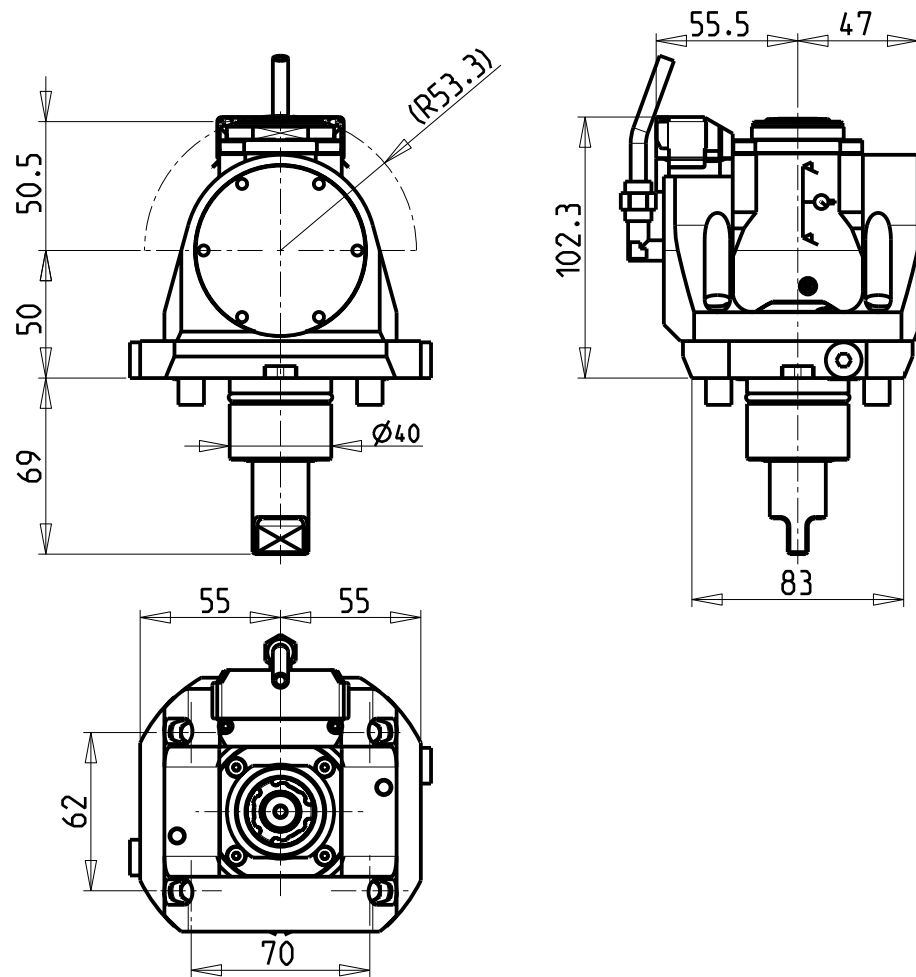

ATTENZIONE - ATTENTION - ACHTUNG

- Per lo smontaggio degli utensili utilizzare sempre la chiave di contrasto come indicato nel manuale d'uso.
- For disassembly of the tools use always the contrast key as mentioned in the user instructions.
- Fuer das Abmontieren der Werkzeuge immer den Gegenschlüssel benutzen wie in der Bedienungsanleitung erwäohnt.

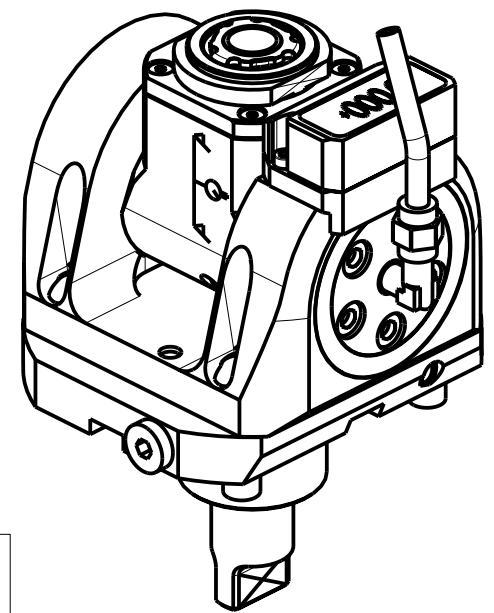

Cod. MT	Mandrino Spindle Spindel	I	RPM	Coppia Max Max Torque Max Drehmoment	Lubrificazione int. Coolant through Innenkuehlung	Lubrificazione est. Ext. coolant Aussenkuehlung	CHIAVI INCLUSE Keys included Schluesssel inbegriffen			
MNZ0395120	ER A 20	1:1	6000	30Nm	-	X	CHUB36	CHUB22	CHESLO8	CHTAER20ZC
MNZ0395220	ER A 20	1:1	6000	30Nm	P=70bar	X	CHUB36	CHUB22	CHESLO8	CHTAER20ZC

DMG-MORI
 NZ1500/2000 - NZX1500/2000 - NZX2500 (BMT40) - NT3100/3150/3200 - NT1000/2000 - NTX1000/2000 - NTX1000/2000/2500/3000 2ND GEN. 12ST.
 DURATURN 2050MC/2550MC - NRX2000 - ALX1500/2000/2500 - ECOTURN 450 (BMT40)

MODULO MOTORIZZATO ORIENTABILE +/-90° CON NONIO DIGITALE H=50mm
 +/-90° adjustable angle driven tool with digital display H=50mm
 Angetriebenes Werkzeug schwenkbar +/-90° mit digital display H=50mm

Subject to change without notice.

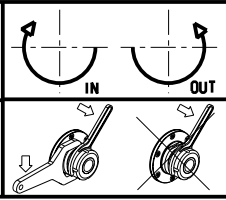

M.T. srl
 Via Casino Albini 480
 Tel. 0541/956034-957884
 Fax 0541/956341
 47842 S. GIOVANNI IN M. (RN)
 e-mail: mtma@mtmarchetti.com
 http://www.mtmarchetti.com



PAGINA MNZ335-1-01

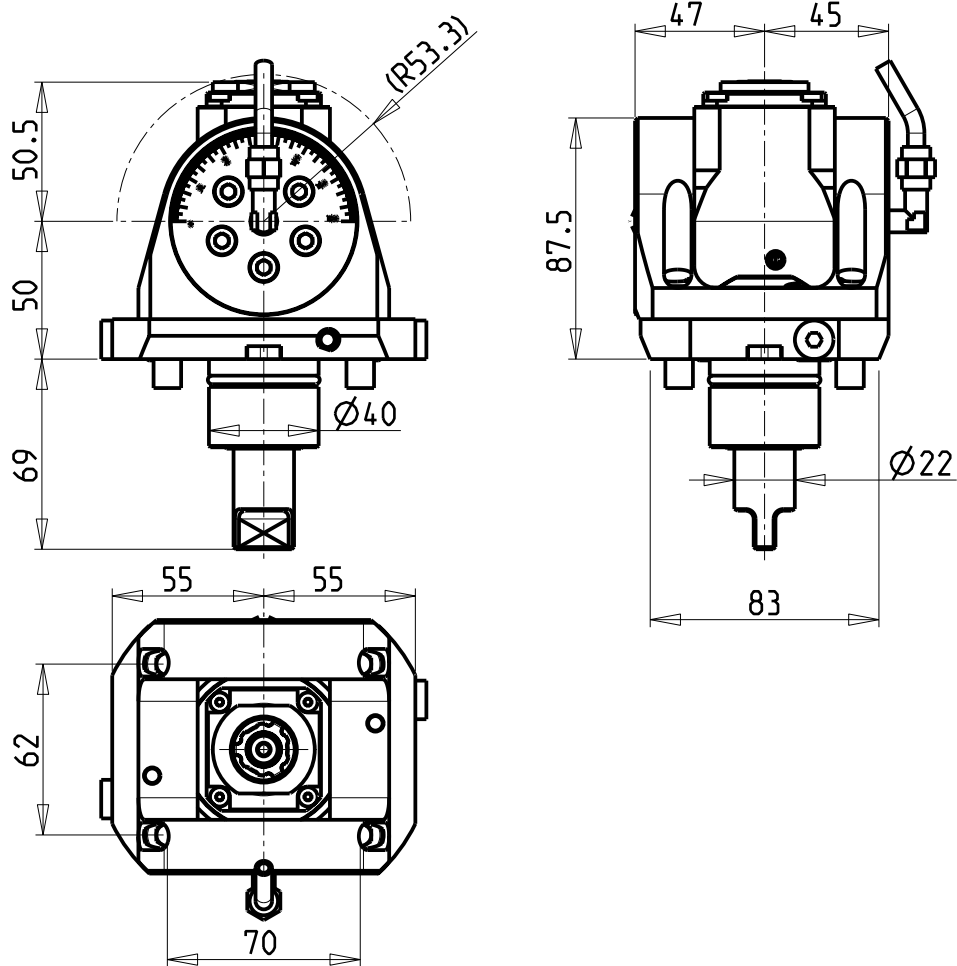

ATTENZIONE - ATTENTION - ACHTUNG

- Per lo smontaggio degli utensili utilizzare sempre la chiave di contrasto come indicato nel manuale d'uso.
- For disassembly of the tools use always the contrast key as mentioned in the user instructions.
- Fuer das Abmontieren der Werkzeuge immer den Gegenschlüssel benutzen wie in der Bedienungsanleitung erwaeht.

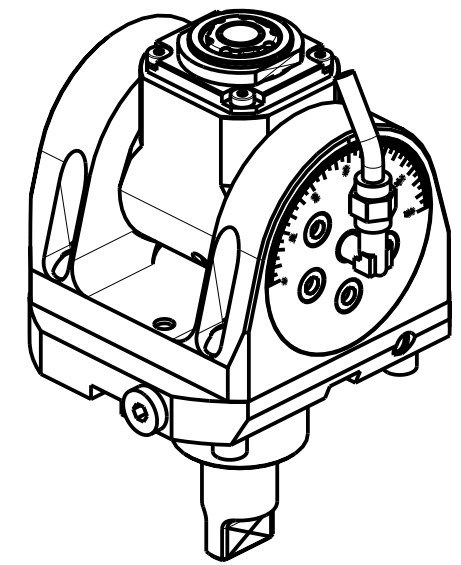

Cod. MT	Mandrino Spindle Spindel	I	RPM	Coppia Max Max Torque Max Drehmoment	Lubrificazione int. Coolant through Innenkuehlung	Lubrificazione est. Ext. coolant Aussenkuehlung	CHIAVI INCLUSE Keys included Schluessel inbegriffen			
MNZ0580120	ER A 20	1:1	12000	30Nm	-	X	CHUB36	CHUB22	CHESLO8	CHTAER20ZC
MNZ0580220	ER A 20	1:1	12000	30Nm	P=70bar	X	CHUB36	CHUB22	CHESLO8	CHTAER20ZC

DMG-MORI
 NZ1500/2000 - NZX1500/2000 - NZX2500 (BMT40) - NTX1000/2000 - NTX1000/2000/2500/3000 2ND GEN. 12ST. - NRX2000 - ALX1500/2000/2500

MODULO MOTORIZZATO ORIENTABILE +/-90° 12000 RPM H=50mm
 +/-90° adjustable angle driven tool 12000 rpm H=50mm
 Angetriebenes Werkzeug schwenkbar +/-90° 12000 rpm H=50mm

Subject to change without notice.

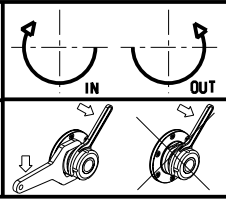

M.T. srl
 Via Casino Albini 480
 Tel. 0541/956034-957884
 Fax 0541/956341
 47842 S. GIOVANNI IN M. (RN)
 e-mail: mtma@mtmarchetti.com
 http://www.mtmarchetti.com



PAGINA MNZ335-1-02

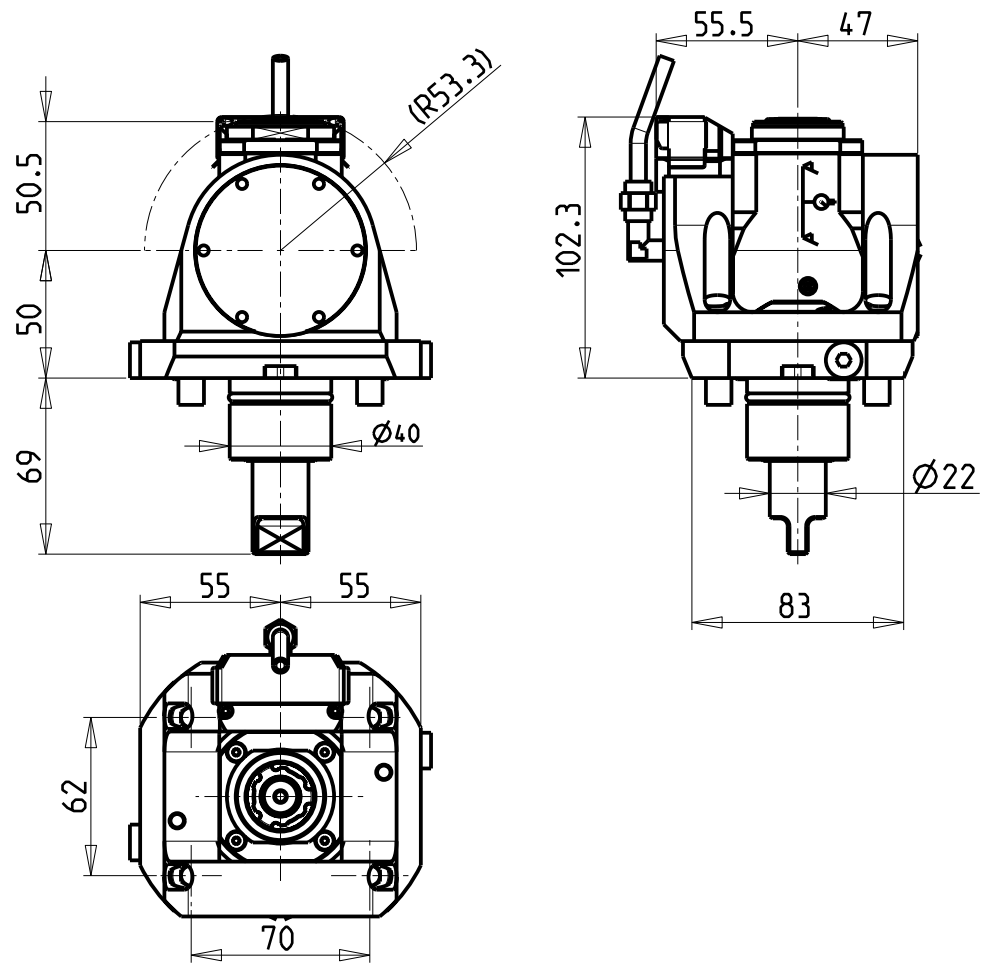

ATTENZIONE - ATTENTION - ACHTUNG

- Per lo smontaggio degli utensili utilizzare sempre la chiave di contrasto come indicato nel manuale d'uso.
- For disassembly of the tools use always the contrast key as mentioned in the user instructions.
- Fuer das Abmontieren der Werkzeuge immer den Gegenschlüssel benutzen wie in der Bedienungsanleitung erwäohnt.

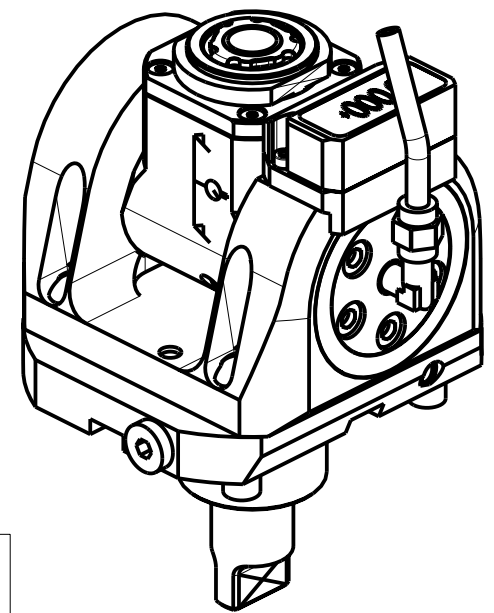

Cod. MT	Mandrino Spindle Spindel	I	RPM	Coppia Max Max Torque Max Drehmoment	Lubrificazione int. Coolant through Innenkuehlung	Lubrificazione est. Ext. coolant Aussenkuehlung	CHIAVI INCLUSE Keys included Schluessel inbegriffen			
MNZ0585120	ER A 20	1:1	12000	30Nm	-	X	CHUB36	CHUB22	CHESLO8	CHTAER20ZC
MNZ0585220	ER A 20	1:1	12000	30Nm	P=70bar	X	CHUB36	CHUB22	CHESLO8	CHTAER20ZC

DMG-MORI
 NZ1500/2000 - NZX1500/2000 - NZX2500 (BMT40) - NTX1000/2000 - NTX1000/2000/2500/3000 2ND GEN. 12ST. - NRX2000 - ALX1500/2000/2500

MODULO MOTORIZZATO ORIENTABILE +/-90° 12000 RPM CON NONIO DIGITALE H=50mm
 +/-90° adjustable angle driven tool 12000 rpm with digital display H=50mm
 Angetriebenes Werkzeug schwenkbar +/-90° 12000 rpm mit digital display H=50mm

Subject to change without notice.

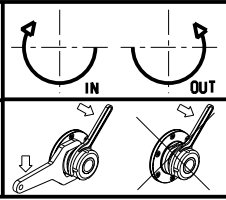

M.T. srl
 Via Casino Albini 480
 Tel. 0541/956034-957884
 Fax 0541/956341
 47842 S. GIOVANNI IN M. (RN)
 e-mail: mtma@mtmarchetti.com
 http://www.mtmarchetti.com



PAGINA MNZ335-1-03

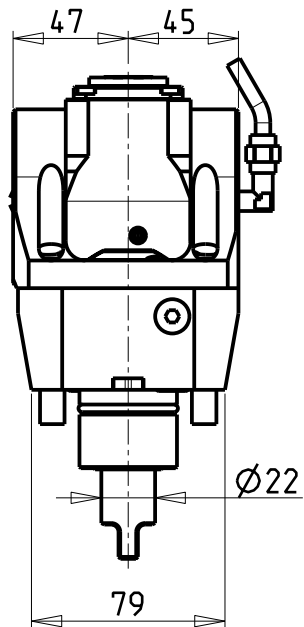
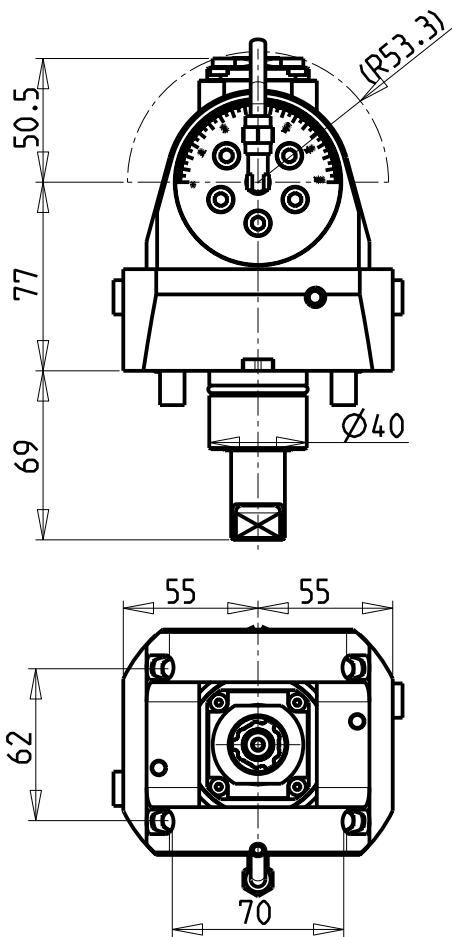

ATTENZIONE - ATTENTION - ACHTUNG

- VERIFICARE LE MISURE DI INGOMBRO PER POSSIBILE INTERFERENZA SU ALCUNI MODELLI DI MACCHINE
- Please check the overall sizes for possible interferences on some machine models
- Bitte überprüfen sie das ausmass um mögliche interferenzen auf einigen maschinen modellen zu vermeiden

ATTENZIONE - ATTENTION - ACHTUNG

- Per lo smontaggio degli utensili utilizzare sempre la chiave di contrasto come indicato nel manuale d'uso.
- For disassembly of the tools use always the contrast key as mentioned in the user instructions.
- Fuer das Abmontieren der Werkzeuge immer den Gegenschlüssel benutzen wie in der Bedienungsanleitung erwaeht.

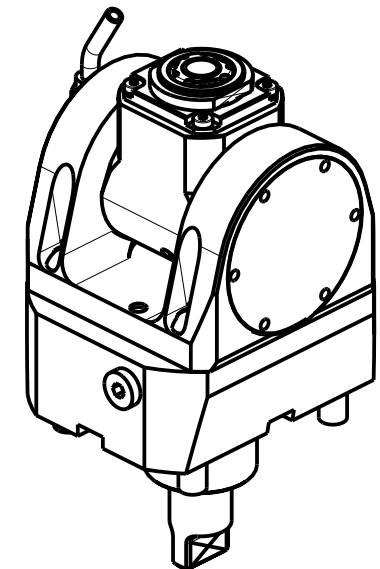
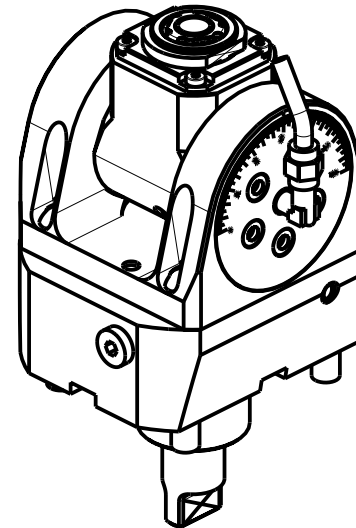

Cod. MT	Mandrino Spindle Spindel	I	RPM	Coppia Max Max Torque Max Drehmoment	Lubrificazione int. Coolant through Innenkuehlung	Lubrificazione est. Ext. coolant Aussenkuehlung	CHIAVI INCLUSE Keys included Schlüssel inbegriffen			
							CHUB36	CHUB22	CHESL08	CHTAER20ZC
MNZ0391120	ER A 20	1:1	6000	30Nm		X	CHUB36	CHUB22	CHESL08	CHTAER20ZC
MNZ0391220	ER A 20	1:1	6000	30Nm	P=70bar	X	CHUB36	CHUB22	CHESL08	CHTAER20ZC

DMG-MORI

NZ1500/2000 - NZX1500/2000 - NZX2500 (BMT40) - NT3100/3150/3200 - NL1500/2000/2500 20 STAZ. - NLX1500/2000/2500 20 STAZ. - NT1000/2000
NTX1000/2000 - NTX1000/2000/2500/3000 2ND GEN. 12ST. - DURATURN 2050MC/2550MC - NRX2000 - ALX1500/2000/2500 - ECOTURN 450 (BMT40)

MODULO MOTORIZZATO ORIENTABILE +/-90° H=77mm

+/-90° adjustable angle driven tool H=77mm

Angetriebenes Werkzeug schwenkbar +/-90° H=77mm

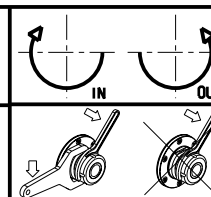

M.T. srl

Via Casino Albini 480
Tel. 0541/956034-957884
Fax 0541/956341

47842 S. GIOVANNI IN M. (RN)
e-mail: mtma@mtmarchetti.com
http://www.mtmarchetti.com



PAGINA MNZ335-1-10

Subject to change without notice.

10/2021

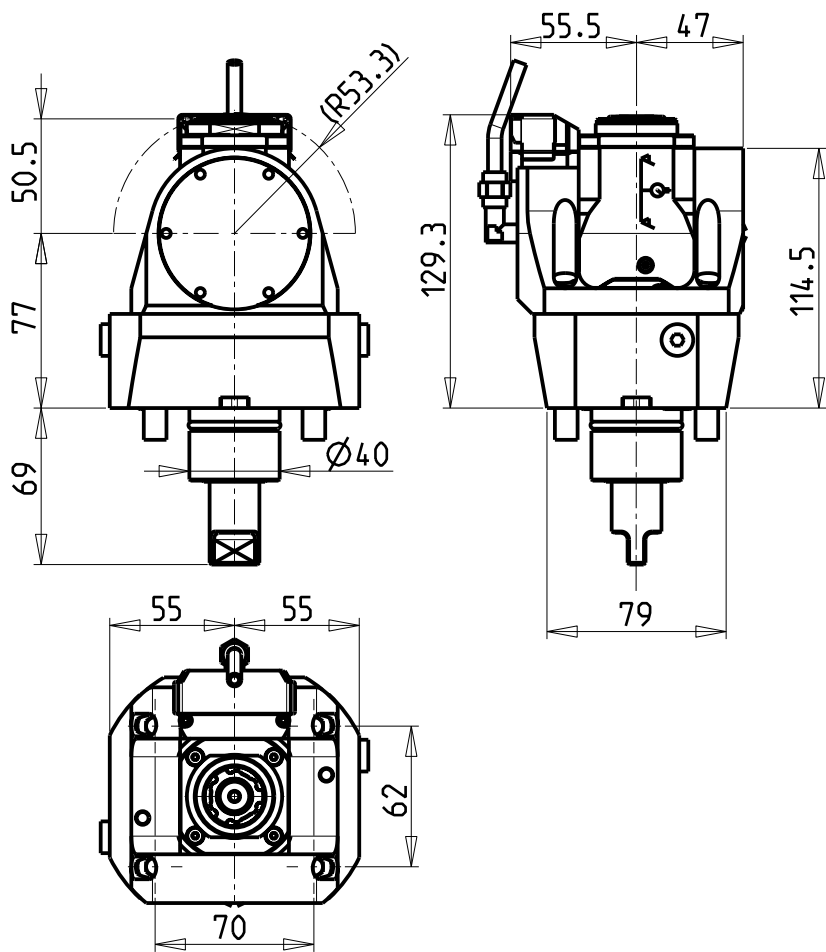

ATTENZIONE - ATTENTION - ACHTUNG

- VERIFICARE LE MISURE DI INGOMBRO PER POSSIBILE INTERFERENZA SU ALCUNI MODELLI DI MACCHINE
- Please check the overall sizes for possible interferences on some machine models
- Bitte überprüfen sie das ausmass um mögliche interferenzen auf einigen maschinen modellen zu vermeiden

ATTENZIONE - ATTENTION - ACHTUNG

- Per lo smontaggio degli utensili utilizzare sempre la chiave di contrasto come indicato nel manuale d'uso.
- For disassembly of the tools use always the contrast key as mentioned in the user instructions.
- Fuer das Abmontieren der Werkzeuge immer den Gegenschlüssel benutzen wie in der Bedienungsanleitung erwaeht.

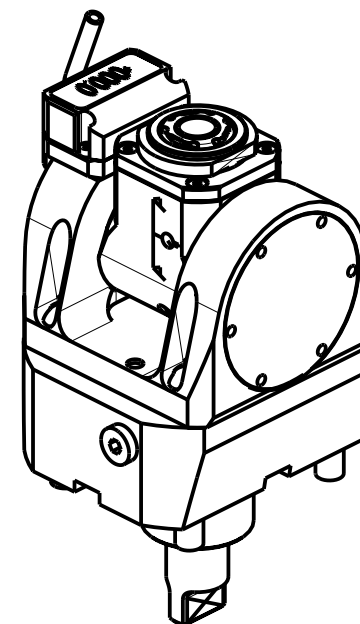
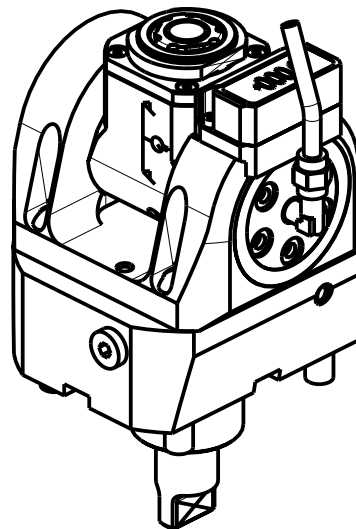

Cod. MT	Mandrino Spindle Spindel	I	RPM	Coppia Max Max Torque Max Drehmoment	Lubrificazione int. Coolant through Innenkuehlung	Lubrificazione est. Ext. coolant Aussenkuehlung	CHIAVI INCLUSE Keys included Schlüssel inbegriffen			
MNZ0396120	ER A 20	1:1	6000	30Nm	-	X	CHUB36	CHUB22	CHESL08	CHTAER20ZC
MNZ0396220	ER A 20	1:1	6000	30Nm	P=70bar	X	CHUB36	CHUB22	CHESL08	CHTAER20ZC

DMG-MORI

NZ1500/2000 - NZX1500/2000 - NZX2500 (BMT40) - NT3100/3150/3200 - NL1500/2000/2500 20 STAZ. - NLX1500/2000/2500 20 STAZ. - NT1000/2000
NTX1000/2000 - NTX1000/2000/2500/3000 2ND GEN. 12ST. - DURATURN 2050MC/2550MC - ALX1500/2000/2500 - ECOTURN 450 (BMT40)

MODULO MOTORIZZATO ORIENTABILE +/-90° CON NONIO DIGITALE H=77mm

+/-90° adjustable angle driven tool with digital display H=77mm

Angetriebenes Werkzeug schwenkbar +/-90° mit digital display H=77mm

Subject to change without notice.

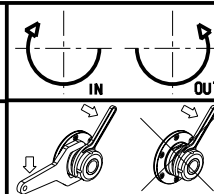

M.T. srl

Via Casino Albini 480
Tel. 0541/956034-957884

Fax 0541/956341

47842 S. GIOVANNI IN M. (RN)

e-mail: mtma@mtmarchetti.com

http://www.mtmarchetti.com



PAGINA MNZ335-1-11

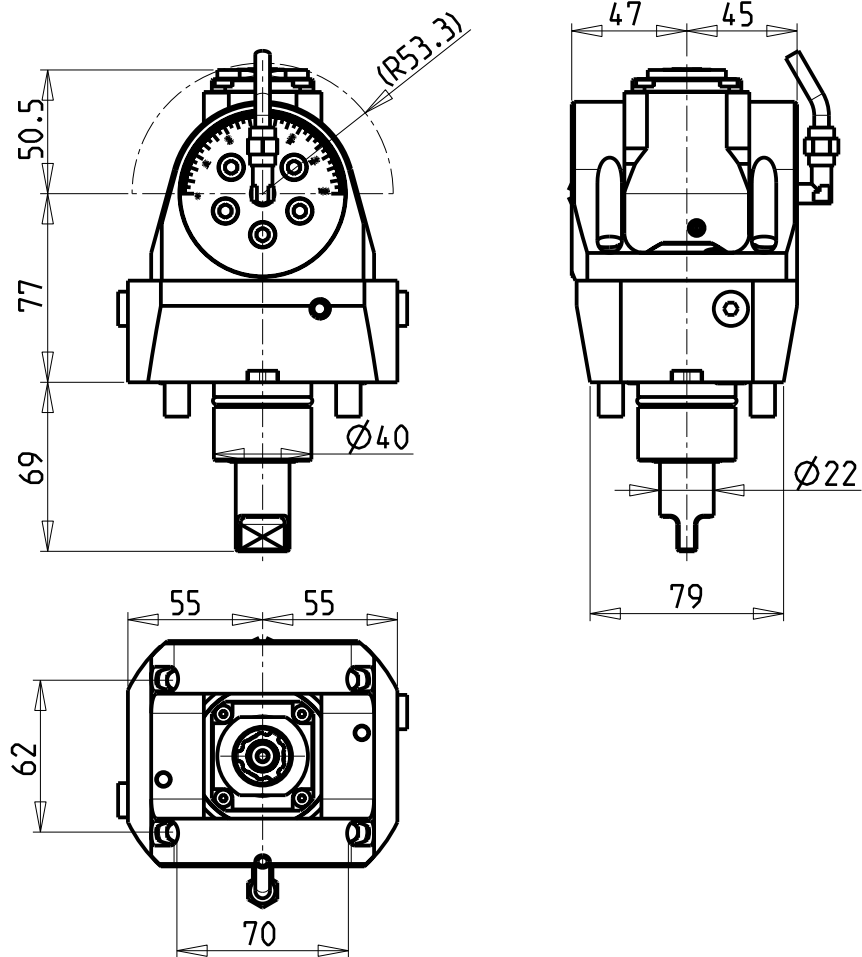

ATTENZIONE - ATTENTION - ACHTUNG

- VERIFICARE LE MISURE DI INGOMBRO PER POSSIBILE INTERFERENZA SU ALCUNI MODELLI DI MACCHINE
- Please check the overall sizes for possible interferences on some machine models
- Bitte überprüfen sie das ausmass um mögliche interferenzen auf einigen maschinen modellen zu vermeiden

ATTENZIONE - ATTENTION - ACHTUNG

- Per lo smontaggio degli utensili utilizzare sempre la chiave di contrasto come indicato nel manuale d'uso.
- For disassembly of the tools use always the contrast key as mentioned in the user instructions.
- Fuer das Abmontieren der Werkzeuge immer den Gegenschlüssel benutzen wie in der Bedienungsanleitung erwaeht.

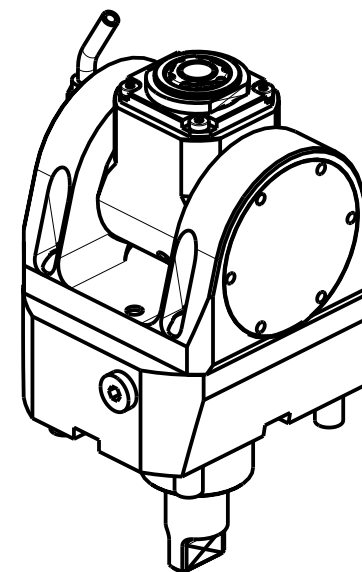
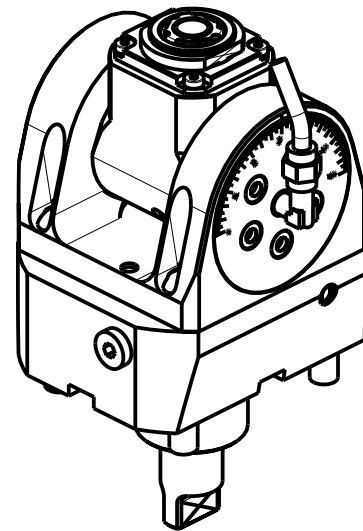

Cod. MT	Mandrino Spindle Spindel	I	RPM	Coppia Max Max Torque Max Drehmoment	Lubrificazione int. Coolant through Innenkuehlung	Lubrificazione est. Ext. coolant Aussenkuehlung	CHIAVI INCLUSE Keys included Schlüssel inbegriffen			
MNZ0581120	ER A 20	1:1	12000	30Nm	-	X	CHUB36	CHUB22	CHESL08	CHTAER20ZC
MNZ0581220	ER A 20	1:1	12000	30Nm	P=70bar	X	CHUB36	CHUB22	CHESL08	CHTAER20ZC

DMG-MORI

NZ1500/2000 - NZX1500/2000 - NZX2500 (BMT40) - NL1500/2000/2500 20 STAZ. - NLX1500/2000/2500 20 STAZ.
 NTX1000/2000 - NTX1000/2000/2500/3000 2ND GEN. 12ST. - NRX2000 - ALX1500/2000/2500

MODULO MOTORIZZATO ORIENTABILE +/-90° 12000 RPM H=77mm

+/-90° adjustable angle driven tool 12000 rpm H=77mm

Angetriebenes Werkzeug schwenkbar +/-90° 12000 rpm H=77mm

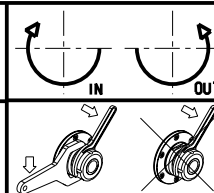

M.T. srl

Via Casino Albini 480
 Tel. 0541/956034-957884
 Fax 0541/956341

47842 S. GIOVANNI IN M. (RN)
 e-mail: mtma@mtmarchetti.com
 http://www.mtmarchetti.com



PAGINA MNZ335-1-12

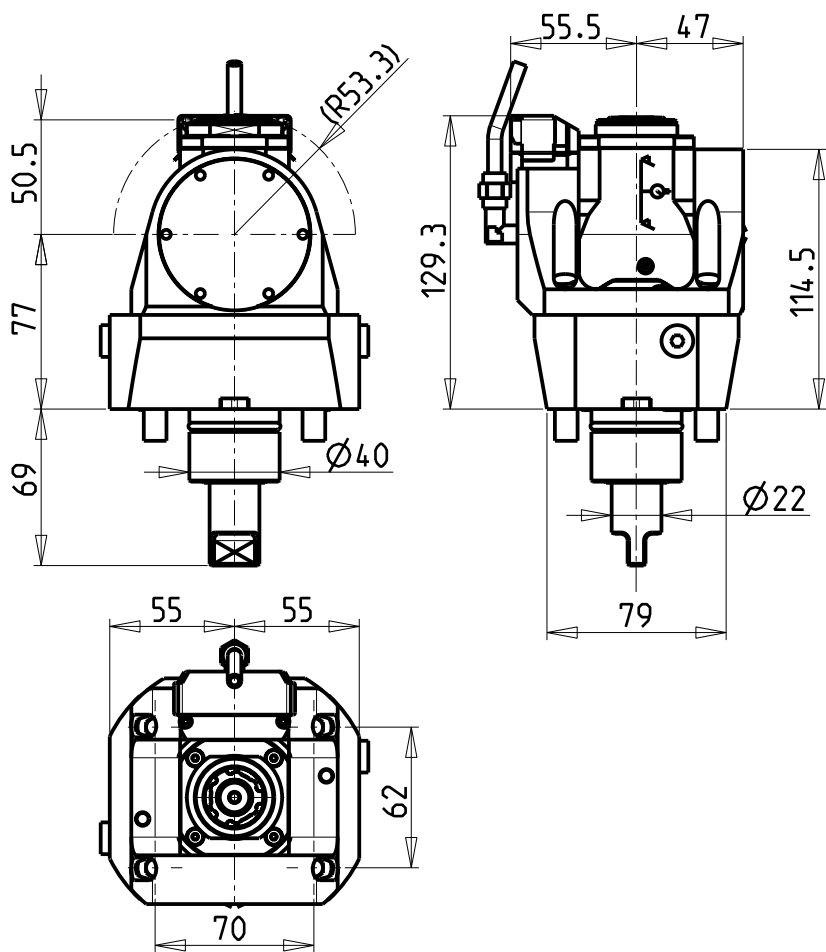

ATTENZIONE - ATTENTION - ACHTUNG

- VERIFICARE LE MISURE DI INGOMBRO PER POSSIBILE INTERFERENZA SU ALCUNI MODELLI DI MACCHINE
- Please check the overall sizes for possible interferences on some machine models
- Bitte überprüfen sie das ausmass um mögliche interferenzen auf einigen maschinen modellen zu vermeiden

ATTENZIONE - ATTENTION - ACHTUNG

- Per lo smontaggio degli utensili utilizzare sempre la chiave di contrasto come indicato nel manuale d'uso.
- For disassembly of the tools use always the contrast key as mentioned in the user instructions.
- Fuer das Abmontieren der Werkzeuge immer den Gegenschlüssel benutzen wie in der Bedienungsanleitung erwaeht.

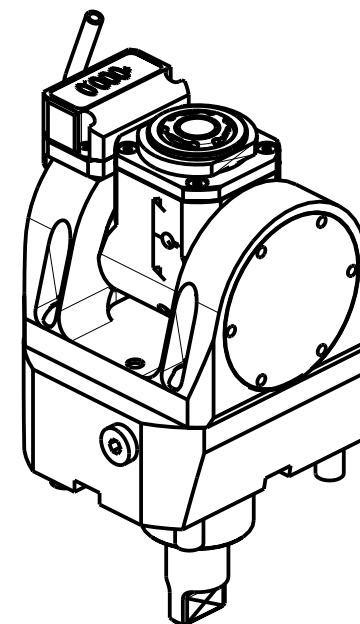
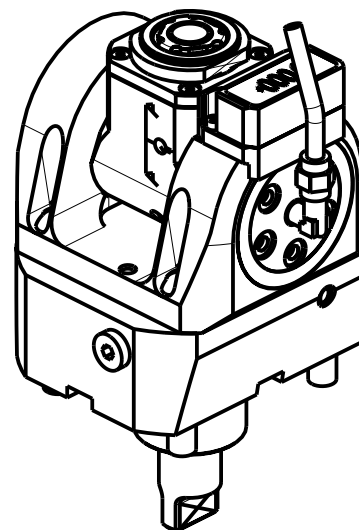

Cod. MT	Mandrino Spindle Spindel	I	RPM	Coppia Max Max Torque Max Drehmoment	Lubrificazione int. Coolant through Innenkuehlung	Lubrificazione est. Ext. coolant Aussenkuehlung	CHIAVI INCLUSE Keys included Schlüssel inbegriffen			
MNZ0586120	ER A 20	1:1	12000	30Nm	-	X	CHUB36	CHUB22	CHESL08	CHTAER20ZC
MNZ0586220	ER A 20	1:1	12000	30Nm	P=70bar	X	CHUB36	CHUB22	CHESL08	CHTAER20ZC

DMG-MORI

NZ1500/2000 - NZX1500/2000 - NZX2500 (BMT40) - NL1500/2000/2500 20 STAZ. - NLX1500/2000/2500 20 STAZ.
 NTX1000/2000 - NTX1000/2000/2500/3000 2ND GEN. 12ST. - NRX2000 - ALX1500/2000/2500

MODULO MOTORIZZATO ORIENTABILE +/-90° 12000 RPM CON NONIO DIGITALE H=77mm

+/-90° adjustable angle driven tool 12000 rpm with digital display H=77mm

Angetriebenes Werkzeug schwenkbar +/-90° 12000 rpm mit digital display H=77mm

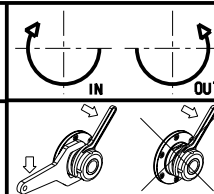

M.T. srl

Via Casino Albini 480
 Tel. 0541/956034-957884
 Fax 0541/956341

47842 S. GIOVANNI IN M. (RN)
 e-mail: mtma@mtmarchetti.com
 http://www.mtmarchetti.com



PAGINA MNZ335-1-13

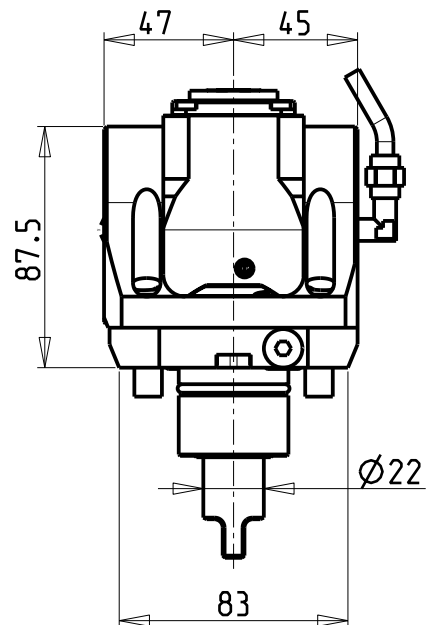
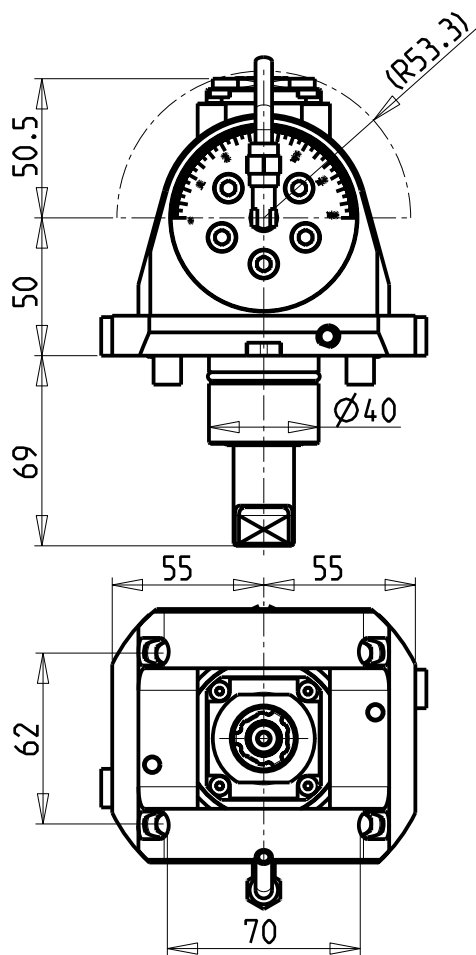

ATTENZIONE - ATTENTION - ACHTUNG

- Per lo smontaggio degli utensili utilizzare sempre la chiave di contrasto come indicato nel manuale d'uso.
- For disassembly of the tools use always the contrast key as mentioned in the user instructions.
- Fuer das Abmontieren der Werkzeuge immer den Gegenschlüssel benutzen wie in der Bedienungsanleitung erwäehnt.

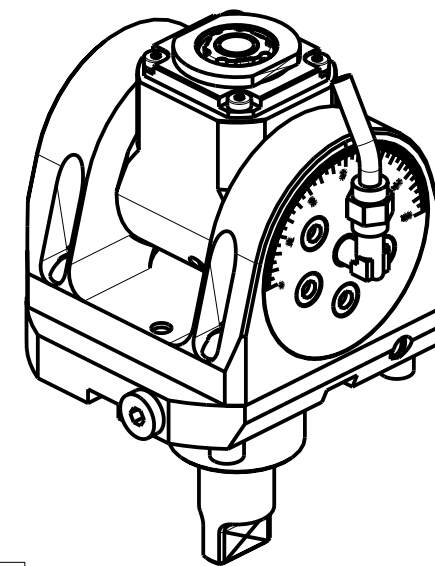

Cod. MT	Mandrino Spindle Spindel	I	RPM	Coppia Max Max Torque Max Drehmoment	Lubrificazione int. Coolant through Innenkuehlung	Lubrificazione est. Ext. coolant Aussenkuehlung	CHIAVI INCLUSE Keys included Schluessel inbegriffen			
							C HUB19_SP3	C HUB32	C HTAER16ZC	C HESL08
MNZ0390316	ERA16	1:2	12000	8Nm		X	C HUB19_SP3	C HUB32	C HTAER16ZC	C HESL08
MNZ0390416	ERA16	1:2	12000	8Nm	P=70bar	X	C HUB19_SP3	C HUB32	C HTAER16ZC	C HESL08

DMG-MORI

NZ1500/2000 - NZX1500/2000 - NZX2500 (BMT40) - NT3100/3150/3200 - NT1000/2000 - NTX1000/2000 - NTX1000/2000/2500/3000 2ND GEN. 12ST. DURATURN 2050MC/2550MC - NRX2000 - ALX1500/2000/2500 - ECOTURN 450 (BMT40)

MODULO MOTORIZZATO ORIENTABILE +/-90° MOLTIPLICATO I=1:2 H=50mm

+/-90° adjustable angle driven tool geared-up I=1:2 H=50mm

Angetriebenes Werkzeug schwenkbar +/-90° uebersetzt I=1:2 H=50mm

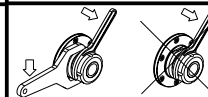
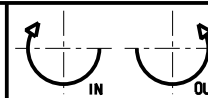

M.T. srl

Via Casino Albini 480
Tel. 0541/956034-957884
Fax 0541/956341

47842 S. GIOVANNI IN M. (RN)
e-mail: mtma@mtmarchetti.com
http://www.mtmarchetti.com



PAGINA MNZ336-1-00

Subject to change without notice.

10/2021

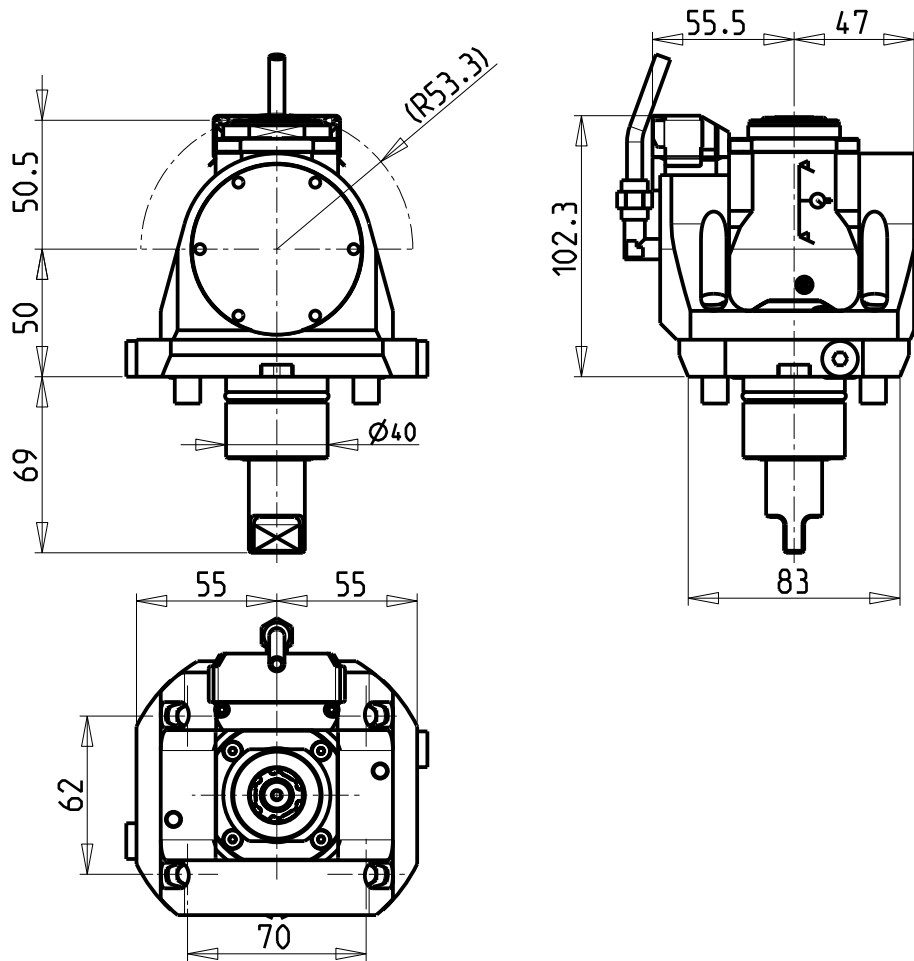

ATTENZIONE - ATTENTION - ACHTUNG

- Per lo smontaggio degli utensili utilizzare sempre la chiave di contrasto come indicato nel manuale d'uso.
- For disassembly of the tools use always the contrast key as mentioned in the user instructions.
- Fuer das Abmontieren der Werkzeuge immer den Gegenschlüssel benutzen wie in der Bedienungsanleitung erwäehnt.

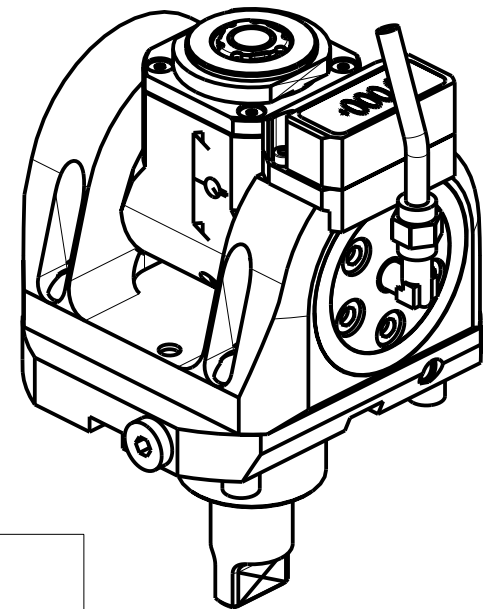

Cod. MT	Mandrino Spindle Spindel	I	RPM	Coppia Max Max Torque Max Drehmoment	Lubrificazione int. Coolant through Innenkuehlung	Lubrificazione est. Ext. coolant Aussenkuehlung	CHIAVI INCLUSE Keys included Schluessel inbegriffen			
MNZ0395316	ERA16	1:2	12000	8Nm	-	X	CHUB19_SP3	CHUB32	CHTAER16ZC	CHESL08
MNZ0395416	ERA16	1:2	12000	8Nm	P=70bar	X	CHUB19_SP3	CHUB32	CHTAER16ZC	CHESL08

DMG-MORI
 NZ1500/2000 - NZX1500/2000 - NZX2500 (BMT40) - NT3100/3150/3200 - NT1000/2000 - NTX1000/2000 - NTX1000/2000/2500/3000 2ND GEN. 12ST.
 DURATURN 2050MC/2550MC - NRX2000 - ALX1500/2000/2500 - ECOTURN 450 (BMT40)

MODULO MOTORIZZATO ORIENTABILE +/-90° MOLTIPLICATO I=1:2 CON NONIO DIGITALE H=50mm
 +/-90° adjustable angle driven tool geared-up I=1:2 with digital display H=50mm
 Angetriebenes Werkzeug schwenkbar +/-90° uebersetzt I=1:2 mit digital display H=50mm

Subject to change without notice.

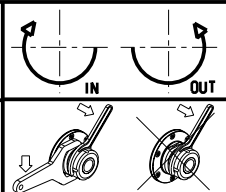

M.T. srl
 Via Casino Albini 480
 Tel. 0541/956034-957884
 Fax 0541/956341
 47842 S. GIOVANNI IN M. (RN)
 e-mail: mtma@mtmarchetti.com
 http://www.mtmarchetti.com



PAGINA MNZ336-1-01

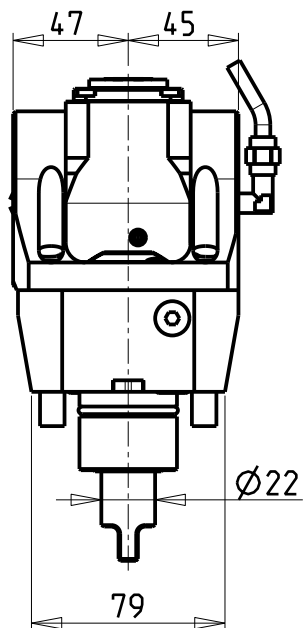
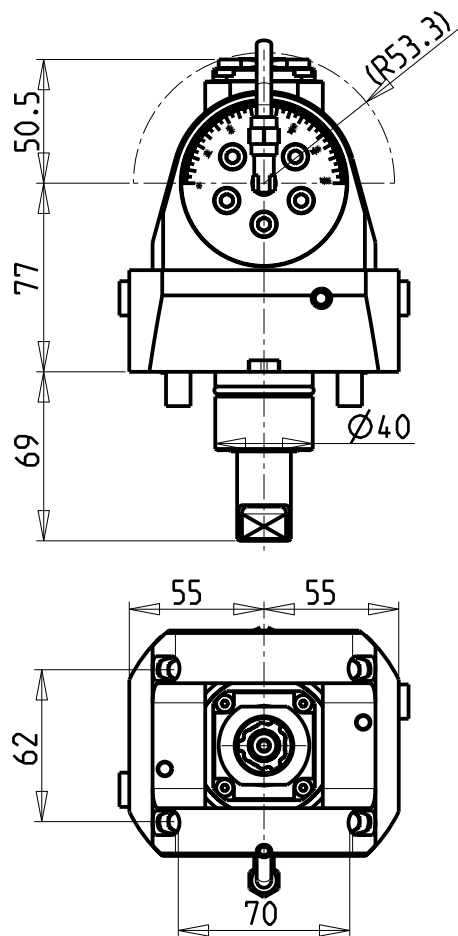

ATTENZIONE - ATTENTION - ACHTUNG

- VERIFICARE LE MISURE DI INGOMBRO PER POSSIBILE INTERFERENZA SU ALCUNI MODELLI DI MACCHINE
- Please check the overall sizes for possible interferences on some machine models
- Bitte überprüfen sie das ausmass um mögliche interferenzen auf einigen maschinen modellen zu vermeiden

ATTENZIONE - ATTENTION - ACHTUNG

- Per lo smontaggio degli utensili utilizzare sempre la chiave di contrasto come indicato nel manuale d'uso.
- For disassembly of the tools use always the contrast key as mentioned in the user instructions.
- Fuer das Abmontieren der Werkzeuge immer den Gegenschlüssel benutzen wie in der Bedienungsanleitung erwaeht.

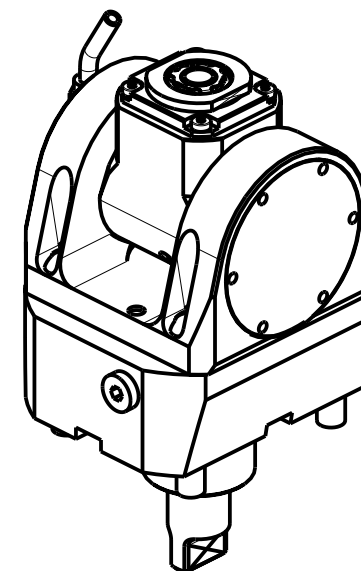
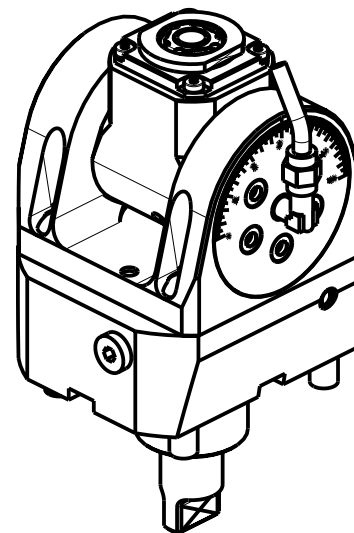

Cod. MT	Mandrino Spindle Spindel	I	RPM	Coppia Max Max Torque Max Drehmoment	Lubrificazione int. Coolant through Innenkuehlung	Lubrificazione est. Ext. coolant Aussenkuehlung	CHIAVI INCLUSE Keys included Schlüssel inbegriffen			
MNZ0391316	ERA16	1:2	12000	8Nm		X	CHUB19_SP3	CHUB32	CHTAER16ZC	CHESL08
MNZ0391416	ERA16	1:2	12000	8Nm	P=70bar	X	CHUB19_SP3	CHUB32	CHTAER16ZC	CHESL08

DMG-MORI

NZ1500/2000 - NZX1500/2000 - NZX2500 (BMT40) - NT3100/3150/3200 - NL1500/2000/2500 20 STAZ. - NLX1500/2000/2500 20 STAZ. - NT1000/2000
NTX1000/2000 - NTX1000/2000/2500/3000 2ND GEN. 12ST. - DURATURN 2050MC/2550MC - NRX2000 - ALX1500/2000/2500 - ECOTURN 450 (BMT40)

MODULO MOTORIZZATO ORIENTABILE +/-90° MOLTIPLICATO I=1:2 H=77mm

+/-90° adjustable angle driven tool geared-up I=1:2 H=77mm

Angetriebenes Werkzeug schwenkbar +/-90° uebersetzt I=1:2 H=77mm

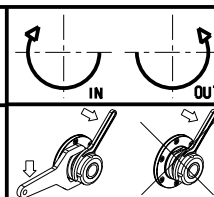

M.T. srl

Via Casino Albini 480
Tel. 0541/956034-957884
Fax 0541/956341
47842 S. GIOVANNI IN M. (RN)
e-mail: mtma@mtmarchetti.com
http://www.mtmarchetti.com



PAGINA MNZ336-1-10

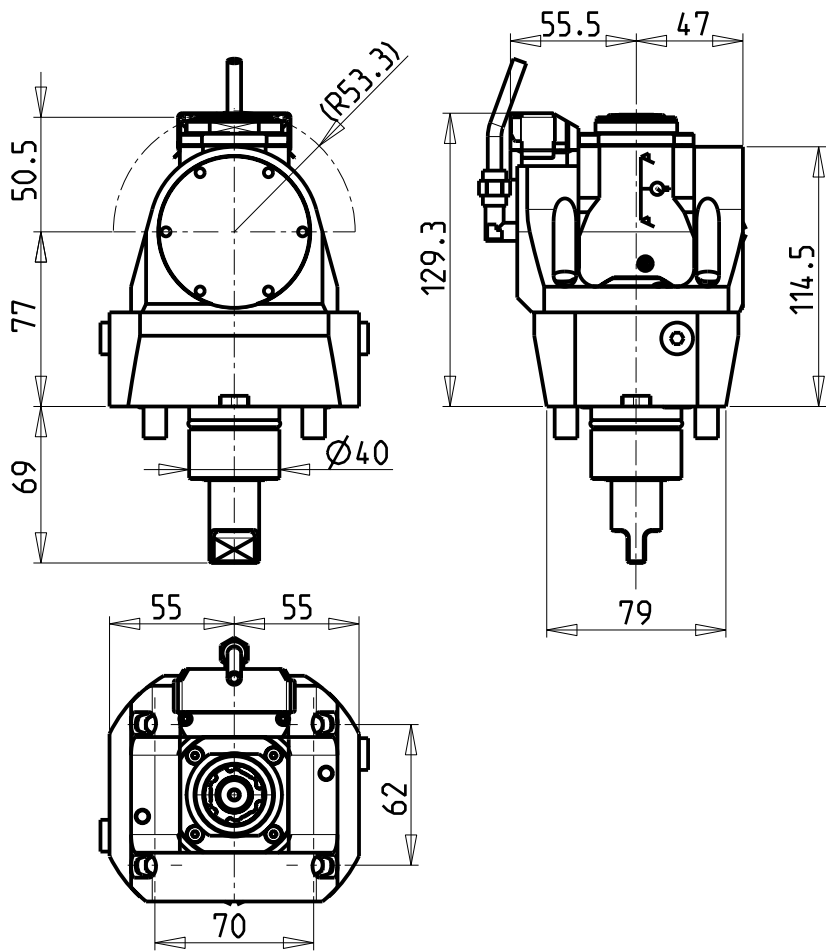

ATTENZIONE - ATTENTION - ACHTUNG

- VERIFICARE LE MISURE DI INGOMBRO PER POSSIBILE INTERFERENZA SU ALCUNI MODELLI DI MACCHINE
- Please check the overall sizes for possible interferences on some machine models
- Bitte überprüfen sie das ausmass um mögliche interferenzen auf einigen maschinen modellen zu vermeiden

ATTENZIONE - ATTENTION - ACHTUNG

- Per lo smontaggio degli utensili utilizzare sempre la chiave di contrasto come indicato nel manuale d'uso.
- For disassembly of the tools use always the contrast key as mentioned in the user instructions.
- Fuer das Abmontieren der Werkzeuge immer den Gegenschlüssel benutzen wie in der Bedienungsanleitung erwaeht.

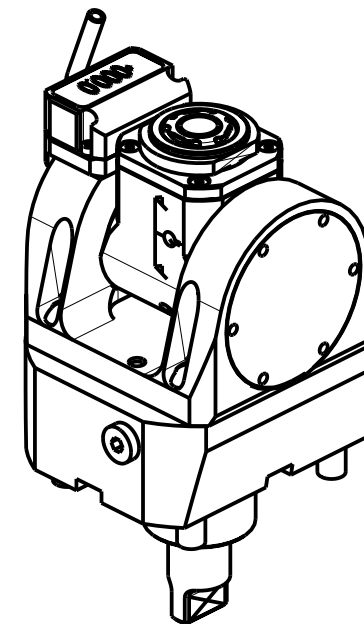
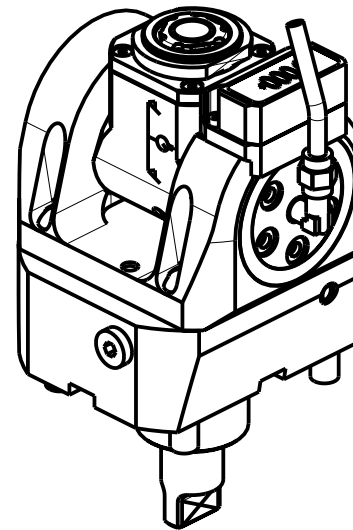

Cod. MT	Mandrino Spindle Spindel	I	RPM	Coppia Max Max Torque Max Drehmoment	Lubrificazione int. Coolant through Innenkuehlung	Lubrificazione est. Ext. coolant Aussenkuehlung	CHIAVI INCLUSE Keys included Schlüssel inbegriffen			
MNZ0396316	ERA16	1:2	12000	8Nm	-	X	CHUB19_SP3	CHUB32	CHTAER16ZC	CHESL08
MNZ0396416	ERA16	1:2	12000	8Nm	P=70bar	X	CHUB19_SP3	CHUB32	CHTAER16ZC	CHESL08

DMG-MORI

NZ1500/2000 - NZX1500/2000 - NZX2500 (BMT40) - NT3100/3150/3200 - NL1500/2000/2500 20 STAZ. - NLX1500/2000/2500 20 STAZ. - NT1000/2000
 NTX1000/2000 - NTX1000/2000/2500/3000 2ND GEN. 12ST. - DURATURN 2050MC/2550MC - ALX1500/2000/2500 - ECOTURN 450 (BMT40)

MODULO MOTORIZZATO ORIENTABILE +/-90° MOLTIPLICATO I=1:2 CON NONIO DIGITALE H=77mm

+/-90° adjustable angle driven tool geared-up I=1:2 with digital display H=77mm

Angetriebenes Werkzeug schwenkbar +/-90° uebersetzt I=1:2 mit digital display H=77mm

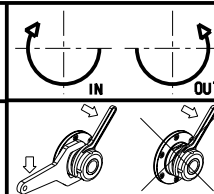

M.T. srl

Via Casino Albini 480
 Tel. 0541/956034-957884
 Fax 0541/956341
 47842 S. GIOVANNI IN M. (RN)
 e-mail: mtma@mtmarchetti.com
 http://www.mtmarchetti.com



PAGINA MNZ336-1-11

Subject to change without notice.

10/2021

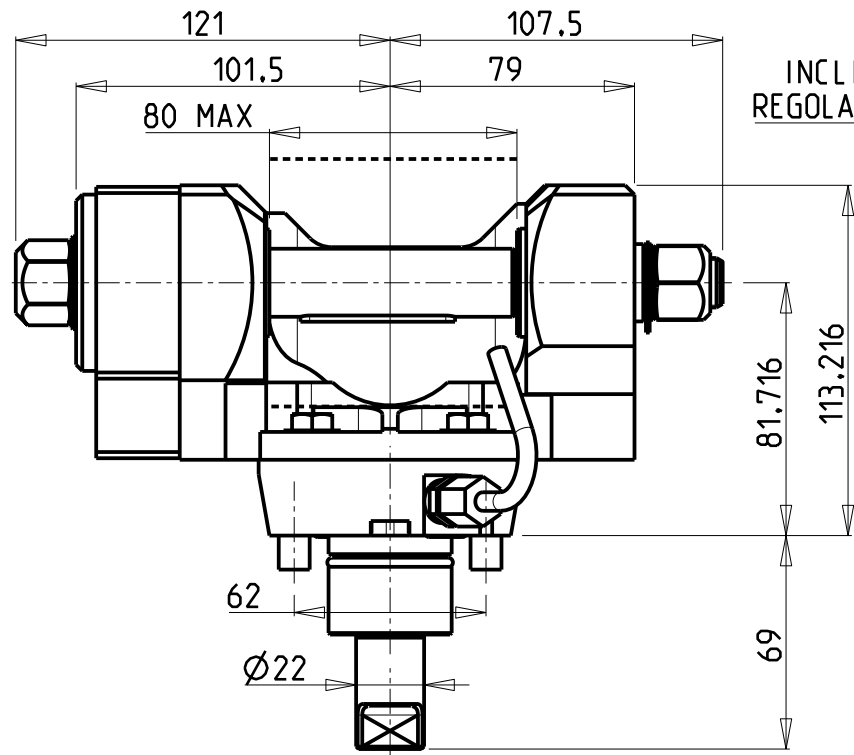
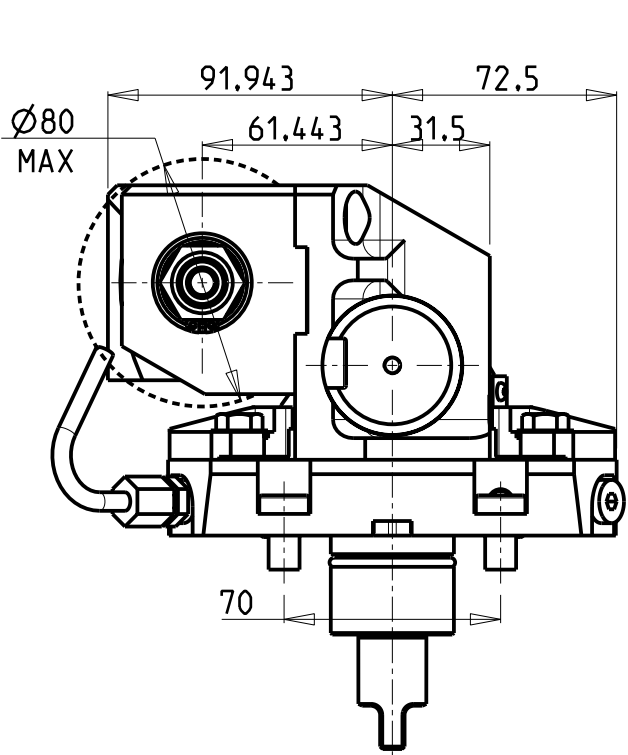

INCLINAZIONE
REGOLABILE ±20°

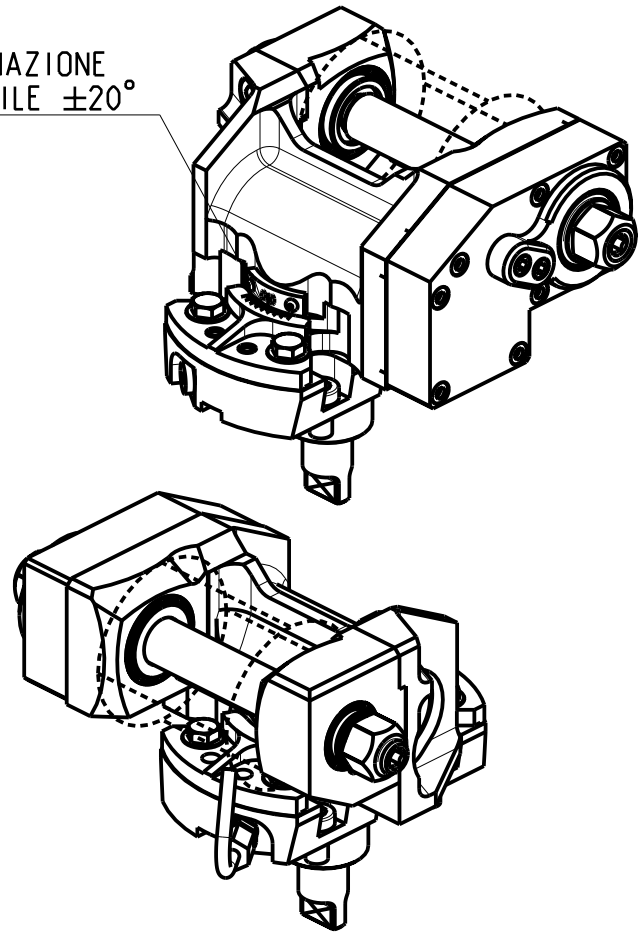

DOTAZIONI - SUPPLIED WITH - AUSSTATTUNG

- N°1 ALBERO + DISTANZIALI
- N°1 SHAFT + SPACER
- N°1 DORN + ABSTANDSSTUECK

PER ALBERI E DISTANZIALI VEDI PAG. TBL250-1-00
FOR SHAFT END SPACER SEE PAGE TBL250-1-00
FUER DORN UND ABSTANDSSTUECK SEITE TBL250-1-00

Cod. MT	I	RPM max	Coppia Max Max Torque Max Drehmoment	Reversibile lato mandrino/contromandrino Reversible sub/main spindle side Umkehrbare Spindel-seite/ Gegenspindel-seite	Lubrificazione est. Ext. coolant Aussenkuehlung	D (mm)	D (Inch)	CHIAVI INCLUDE Keys included Schluessel inbegriffen			
MNZ0201100	1:1	6000	60Nm	X	X	16-22-27-32	3/4"-1"-1 1/4"	CHUB24	CHUB13	CHESL08	CHESL07
MNZ0202100	2:1	3000	80Nm	X	X	16-22-27-32	3/4"-1"-1 1/4"	CHUB24	CHUB13	CHESL08	CHESL07

DMG-MORI

NZ1500/2000 - NZX1500/2000 - NZX2500 (BMT40) - NT3100/3150/3200 - NL1500/2000/2500 20 STAZ. - NLX1500/2000/2500 20 STAZ. - NT1000/2000
NTX1000/2000 - NTX1000/2000/2500/3000 2ND GEN. 12ST. - DURATURN 2050MC/2550MC - ALX1500/2000/2500 - ECOTURN 450 (BMT40)

MODULO MOTORIZZATO PORTACREATORE

Driven gear hobber
Angetriebenes Zahnradwaeltzraes-Werkzeug

Subject to change without notice.

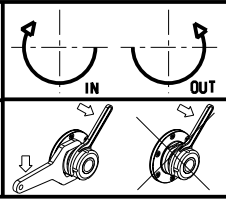

M.T. srl
Via Casino Albini 480
Tel. 0541/956034-957884
Fax 0541/956341
47842 S. GIOVANNI IN M. (RN)
e-mail: mtma@mtmarchetti.com
http://www.mtmarchetti.com



PAGINA MNZ340-1-00

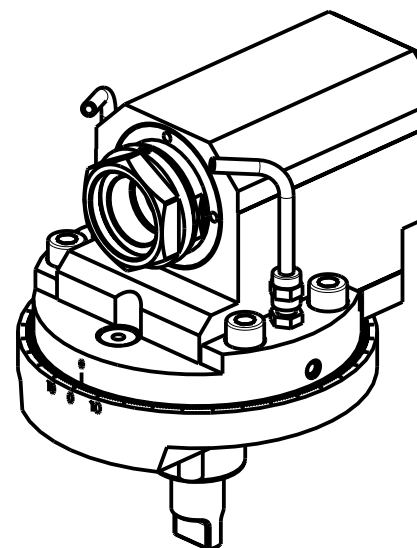
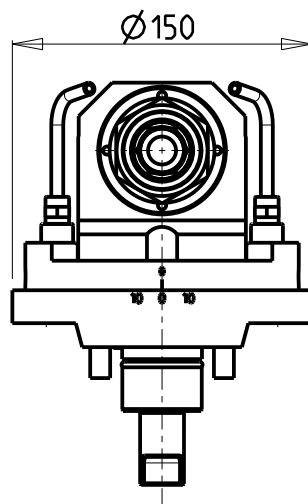
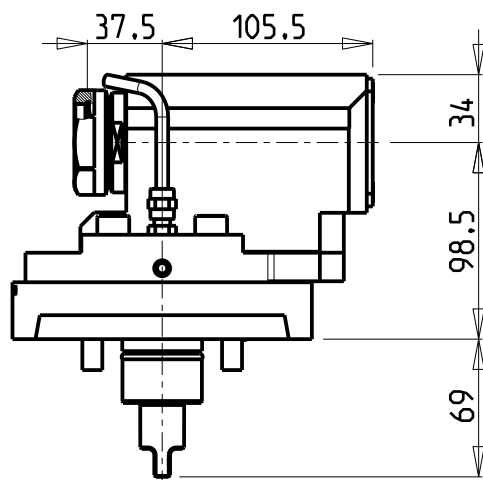
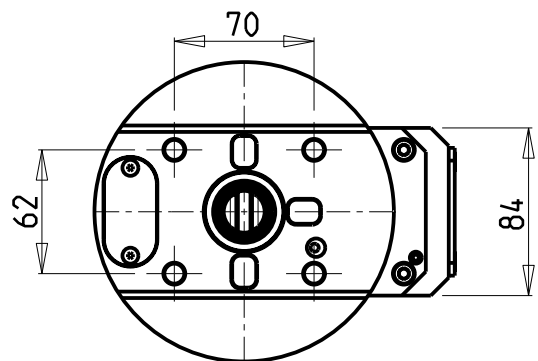

ATTENZIONE - ATTENTION - ACHTUNG

- VERIFICARE LE MISURE DI INGOMBRO PER POSSIBILE INTERFERENZA SU ALCUNI MODELLI DI MACCHINE
- Please check the overall sizes for possible interferences on some machine models
- Bitte überprüfen sie das ausmass um mögliche interferenzen auf einigen maschinen modellen zu vermeiden

PER PORTAUTENSILI MODULARI MTSK-40 VEDI PAG. TBL300-1-40
 FOR MTSK-40 QUICK CHANGE TOOLHOLDERS CLAMPINGS SEE PAGE TBL300-1-40
 FUER MTSK-40 MODULARE WERKZEUGAUFNAHMEN SIEHE SEITE TBL300-1-40

Cod. MT	Mandrino Spindle Spindel	I	RPM	Coppia Max Max Torque Max Drehmoment	Lubr.esterna Ext. coolant Aussenkuehlung	CHIAVI INCLUSE Keys included Schluessel einbegriffen
MNZ0550100	MTSK-40	1:1	6000	50Nm	X	n°2 CHUB46

DMG-MORI

NZ1500/2000 - NZX1500/2000 - NL1500/2000/2500 20 STAZ. - NLX1500/2000/2500 20 STAZ. - ALX1500/2000/2500 - ECOTURN 450 (BMT40)

MODULO MOTORIZZATO ASSIALE MTSK PER POWER SKIVING H=98.5mm

Axial MTSK driven tool for Power Skiving H=98.5mm

Axial MTSK angetriebenes Werkzeug fuer Power Skiving H=98.5mm

Subject to change without notice.

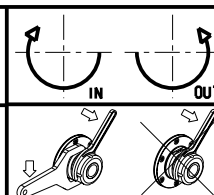

M.T. srl

Via Casino Albini 480
 Tel. 0541/956034-957884
 Fax 0541/956341

47842 S. GIOVANNI IN M. (RN)
 e-mail: mtma@mtmarchetti.com
 http://www.mtmarchetti.com



PAGINA MNZ350-1-00-K

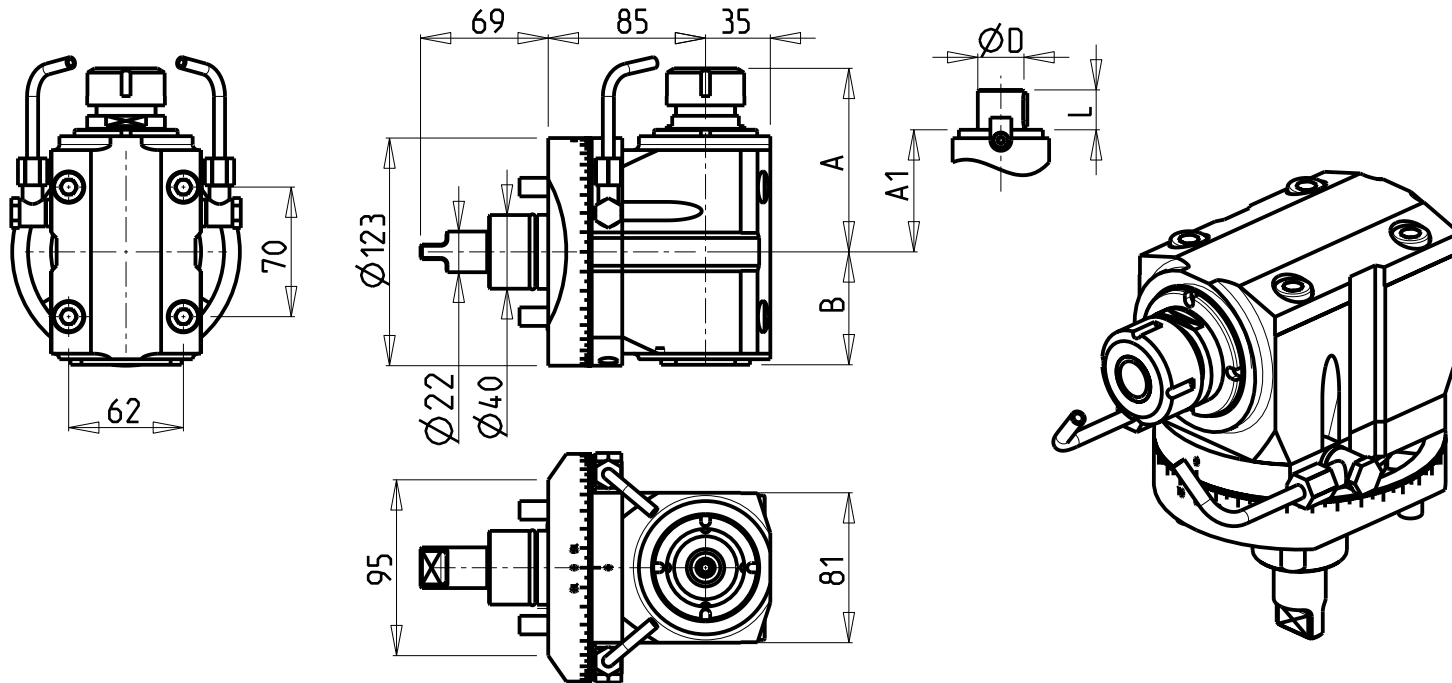

ATTENZIONE - ATTENTION - ACHTUNG

- Per lo smontaggio degli utensili utilizzare sempre la chiave di contrasto come indicato nel manuale d'uso.
- For disassembly of the tools use always the contrast key as mentioned in the user instructions.
- Fuer das Abmontieren der Werkzeuge immer den Gegenschlüssel benutzen wie in der Bedienungsanleitung erwäehnt.

- Chiave inclusa
- Key included
- Schlüssel inbegriffen

Cod. MT	Mandrino Spindle Spindel	I	RPM	Coppia Max Max Torque Max Drehmoment	Reversibile lato mandrino/contromandrino Reversible sub/main spindle side Umkehrbare Spindel-seite/ Gegenspindel-seite	Lubr.interna Coolant through Innenkuehlung	Lubr.esterna Ext. coolant Aussenkuehlung	A	A1	B	D	L	CHIAVI NON INCLUDE Keys not included Schlüssel nicht einbegriffen	
													CHUB36	CHSTER20
MNZ0350120	ER20	1:1	6000	40Nm	X		X	98.16	-	61	-	-	CHUB36	CHSTER20
MNZ0350125	ER25	1:1	6000	40Nm	X		X	99.16	-	61	-	-	CHUB36	CHSTER25
MNZ0350132	ER32	1:1	6000	40Nm	X		X	102.16	-	61	-	-	CHUB36	CHSTER32
MNZ0350225	ER25	1:1	6000	40Nm	X	P=70bar	X	99.16	-	71	-	-	CHUB36	CHSTER25
MNZ0350232	ER32	1:1	6000	40Nm	X	P=70bar	X	102.76	-	71	-	-	CHUB36	CHSTER32
MNZ0351617	Ø16x17	1:1	6000	40Nm	X		X	-	76.5	61	16	17	CHUB36	CH_VTCROCE_M08 *
MNZ0352219	Ø22x19	1:1	6000	40Nm	X		X	-	78.5	61	22	19	CHUB36	CH_VTCROCE_M10 *
MNZ0352721	Ø27x21	1:1	6000	40Nm	X		X	-	79.5	61	27	21	CHUB36	CH_VTCROCE_M12 *
MNZ0351919	Ø3/4"x3/4"	1:1	6000	40Nm	X		X	-	77	61	3/4"	3/4"	CHUB36	CH_VTCROCE_M08 *

DMG-MORI

NZ1500/2000 - NZX1500/2000 - NT3100/3150/3200 - NL1500/2000/2500 20 STAZ. - NLX1500/2000/2500 20 STAZ. - NT1000/2000
 NTX1000/2000 - NTX1000/2000/2500/3000 2ND GEN. 12ST. - DURATURN 2050MC/2550MC - ALX1500/2000/2500 - ECOTURN 450 (BMT40)

MODULO MOTORIZZATO ASSIALE ANGOLARE ±180°
 Axial adjustable angle ±180° driven tool
 Axial angetriebenes Werkzeug schwenkbar ±180°

Subject to change without notice.

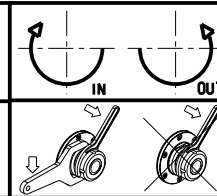

M.T. srl

Via Casino Albini 480
 Tel. 0541/956034-957884
 Fax 0541/956341
 47842 S. GIOVANNI IN M. (RN)
 e-mail: mtma@mtmarchetti.com
 http://www.mtmarchetti.com



PAGINA MNZ355-1-00

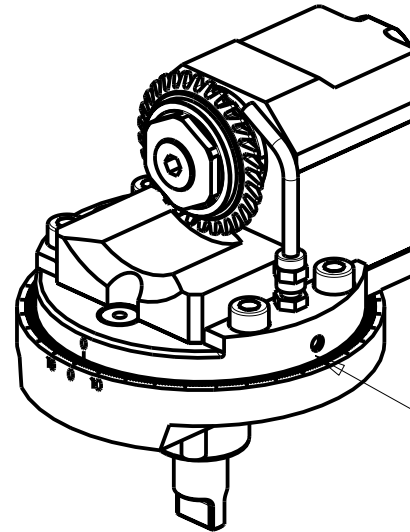
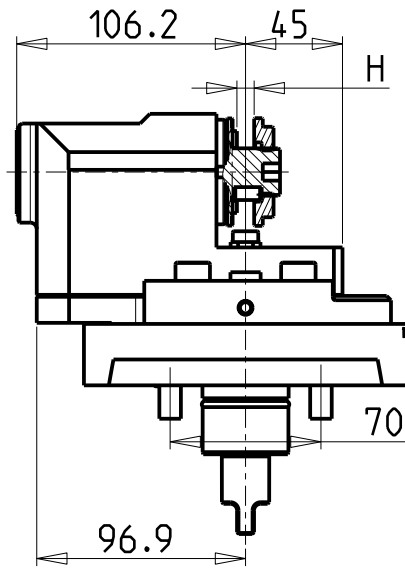
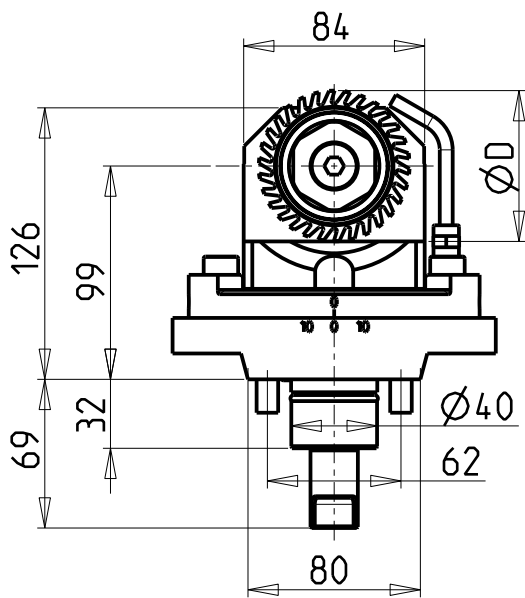

POSSIBILITA' DI
ROTAZIONE 360°

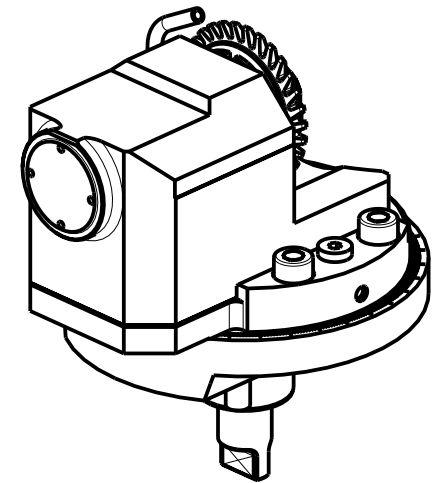
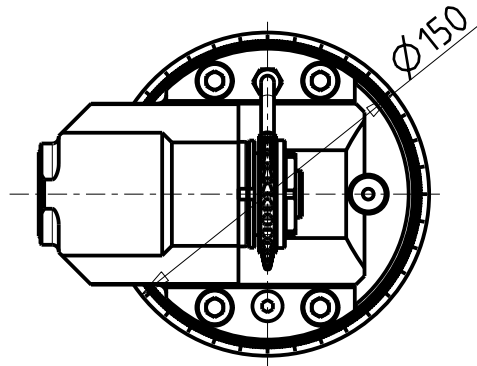

Cod. MT	Mandrino Spindle Spindel	I	RPM	Coppia Max Max Torque Max Drehmoment	Lubrificazione est. Ext. coolant Aussehenkuehlung	ØD	H	CHIAVI INCLUSE Keys included Schlüssel einbegriffen		
MNZ0438022	Ø22x12	1:1	6000	50Nm	X	63-70-80	MAX 12	CHUB38	CHESL07	CHESL08
MNZ0438125	Ø1"x12	1:1	6000	50Nm	X	63-70-80	MAX 12	CHUB38	CHESL07	CHESL08

DMG-MORI
 NZ1500/2000 - NZX1500/2000 - NZX2500 (BMT40) - NT3100/3150/3200 - NL1500/2000/2500 20 STAZ. - NLX1500/2000/2500 20 STAZ. - NT1000/2000
 NTX1000/2000 - NTX1000/2000/2500/3000 2ND GEN. 12ST. - DURATURN 2050MC/2550MC - ALX1500/2000/2500 - ECOTURN 450 (BMT40)

MODULO MOTORIZZATO PER VITI SENZA FINE
 Driven tool for worm screws
 Angetriebenes Werkzeug fuer schrauben ohne ende

Subject to change without notice.

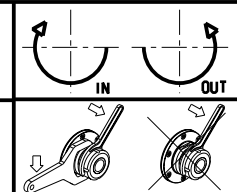

M.T. srl
 Via Casino Albini 480
 Tel. 0541/956034-957884
 Fax 0541/956341
 47842 S. GIOVANNI IN M. (RN)
 e-mail: mtma@mtmarchetti.com
 http://www.mtmarchetti.com



PAGINA MNZ359-1-00

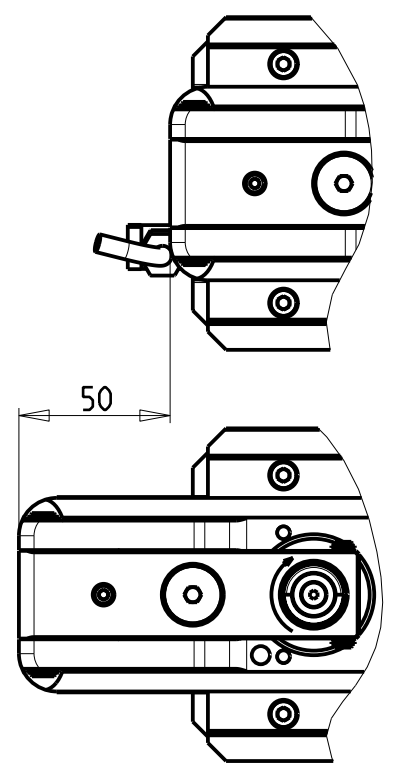
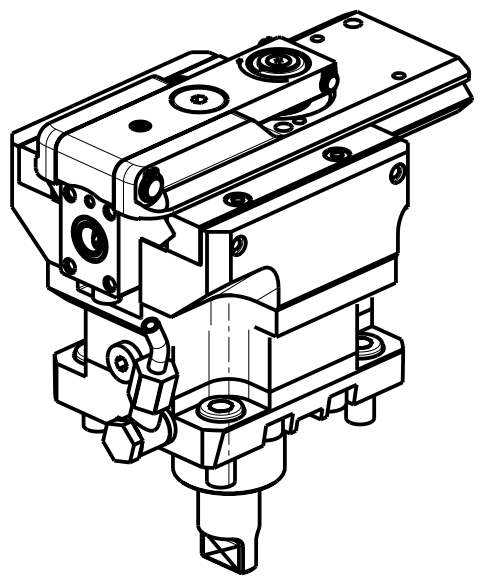
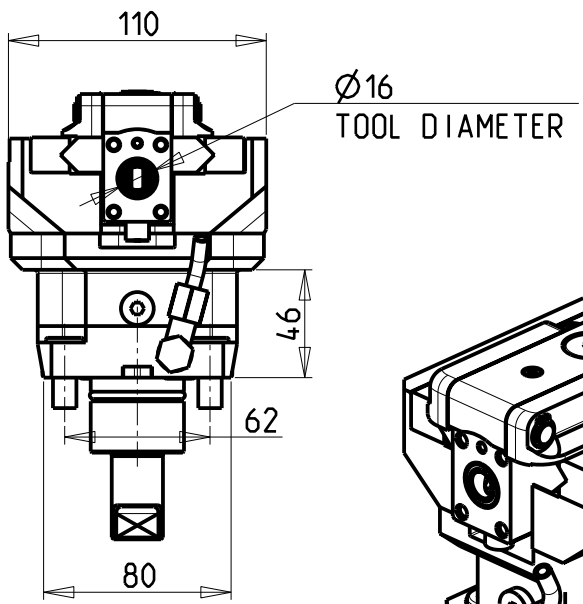
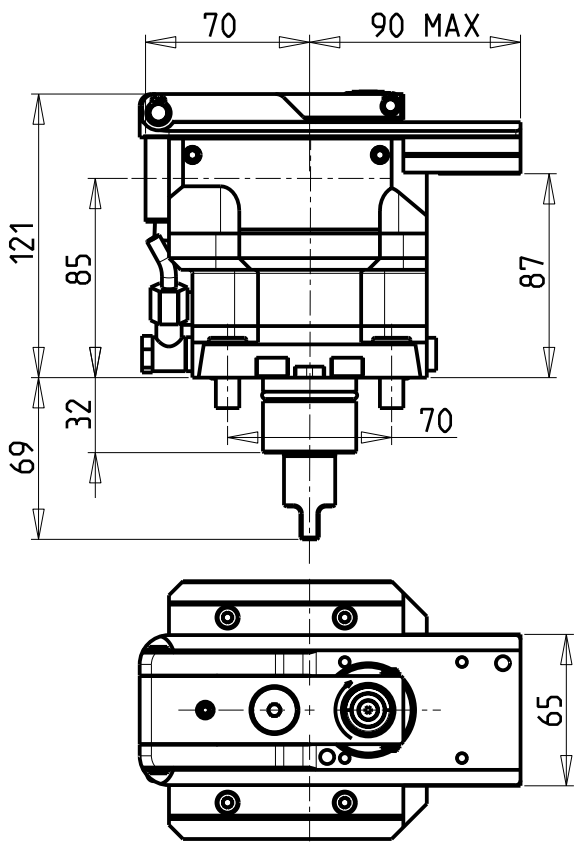

DOTAZIONI - SUPPLIED WITH - AUSSTATTUNG

N*1 Boccola di riduz. Ø16-Ø12 e N*1 Boccola di riduz. Ø16-Ø10
 N*1 Reduction bush Ø16-Ø12 and N*1 Reduction bush Ø16-Ø10
 N*1 Reduzierbuchsen Ø16-Ø12 und N*1 Reduzierbuchsen Ø16-Ø10

PER UTENSILI STOZZATORI VEDI PAG. TBL400-1-00
 FOR DRIVEN SLOTTING TOOL CUTTING-TOOLS SEE PAGE TBL400-1-00
 FÜR NUTENSTOSS-WERKZEUG SCHNEIDWERKZEUGE SIEHE SEITE TBL400-1-00

Cod. MT	I	RPM MAX	Reversibile lato mandrino/contromandrino Reversible sub/main spindle side Umkehrbare Spindel-seite/ Gegenspindel-seite	Lubr. esterna Ext. coolant Aussenkuehlung
MNZ0420100	4:1	2000	X	X

DMG-MORI
 NZ1500/2000 - NZX1500/2000 - NZX2500 (BMT40) - NT3100/3150/3200 - NL1500/2000/2500 20 STAZ. - NLX1500/2000/2500 20 STAZ.
 NTX1000/2000/2500/3000 2ND GEN. 12ST. - DURATURN 2050MC/2550MC - NRX2000 - ALX1500/2000/2500 - ECOTURN 450 (BMT40)
MODULO MOTORIZZATO STOZZATORE CORSA 50mm H=85mm
 Slotting driven tool 50mm stroke H=85mm
 Keilnutenstossmaschine 50mm Hub H=85mm

M.T. srl
 Via Casino Albini 480
 Tel. 0541/956034-957884
 Fax 0541/956341
 47842 S. GIOVANNI IN M. (RN)
 e-mail: mtma@mtmarchetti.com
 http://www.mtmarchetti.com



PAGINA MNZ360-1-00

Subject to change without notice.

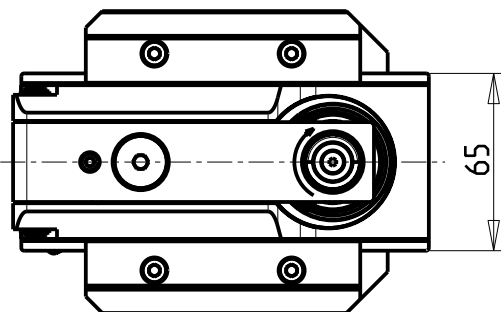
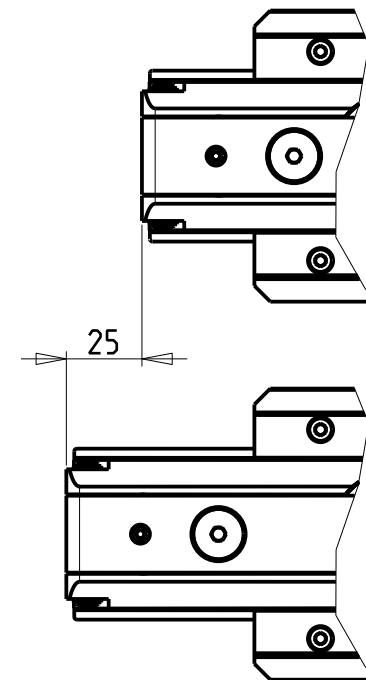
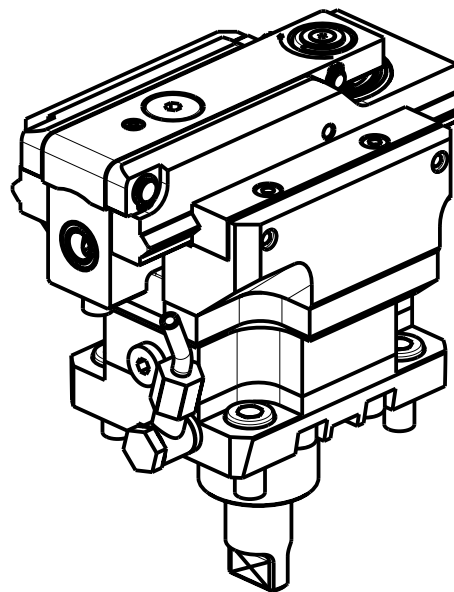
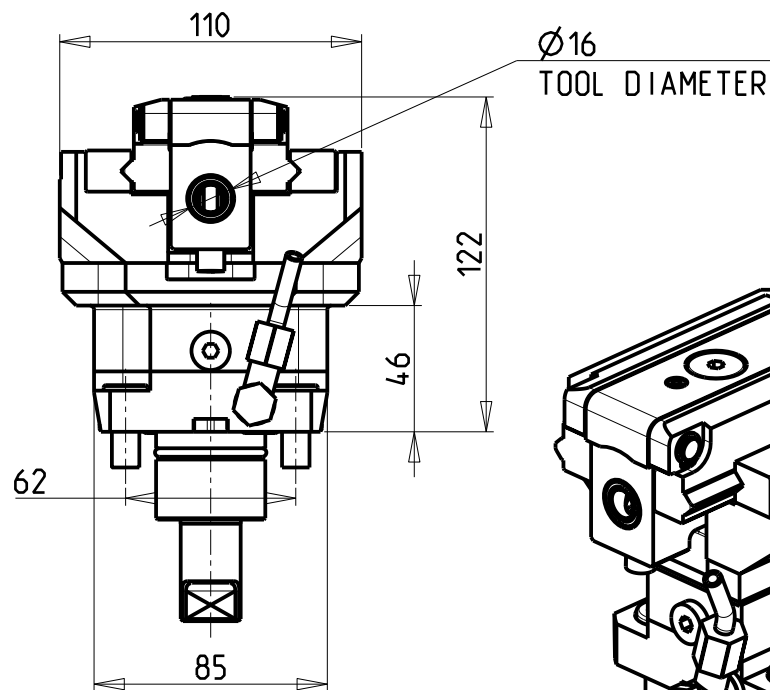
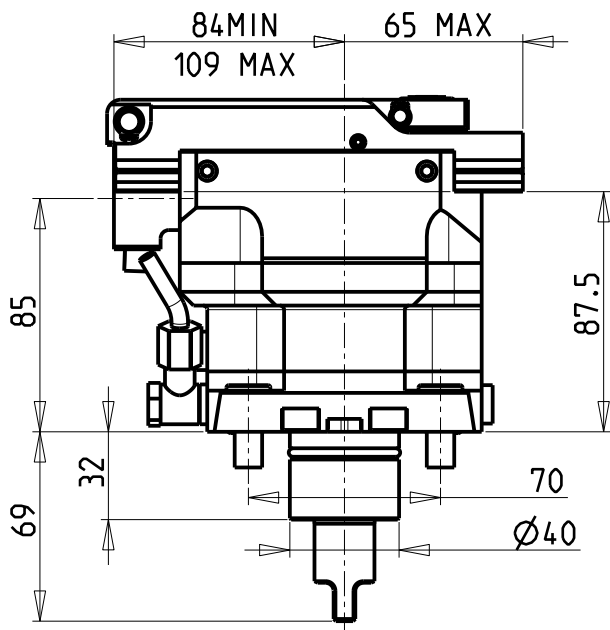

DOTAZIONI - SUPPLIED WITH - AUSSTATTUNG

N°1 Boccola di riduz. Ø16-Ø12 e N°1 Boccola di riduz. Ø16-Ø10
 N°1 Reduction bush Ø16-Ø12 and N°1 Reduction bush Ø16-Ø10
 N°1 Reduzierbuchsen Ø16-Ø12 und N°1 Reduzierbuchsen Ø16-Ø10

PER UTENSILI STOZZATORI VEDI PAG. TBL400-1-00
 FOR DRIVEN SLOTTING TOOL CUTTING-TOOLS SEE PAGE TBL400-1-00
 FÜR NUTENSTOSS-WERKZEUG SCHNEIDWERKZEUGE SIEHE SEITE TBL400-1-00

Cod. MT	I	RPM MAX	Reversibile lato mandrino/contromandrino Reversible sub/main spindle side Umkehrbare Spindelseite/ Gegenspindelseite	Lubr. esterna Ext. coolant Aussenkuehlung
MNZ0420200	4:1	2400	X	X

DMG-MORI

NZ1500/2000 - NZX1500/2000 - NZX2500 (BMT40) - NT3100/3150/3200 - NL1500/2000/2500 20 STAZ. - NLX1500/2000/2500 20 STAZ. - NT1000/2000
 NTX1000/2000/2500/3000 2ND GEN. 12ST. - DURATURN 2050MC/2550MC - NRX2000 - ALX1500/2000/2500 - ECOTURN 450 (BMT40)

MODULO MOTORIZZATO STOZZATORE CORSA 25mm H=85mm

Slotting driven tool 25mm stroke H=85mm

Keilnutenstossmaschine 25mm Hub H=85mm

Subject to change without notice.

M.T. srl

Via Casino Albini 480
 Tel. 0541/956034-957884
 Fax 0541/956341
 47842 S. GIOVANNI IN M. (RN)
 e-mail: mtma@mtmarchetti.com
 http://www.mtmarchetti.com



PAGINA MNZ360-1-01

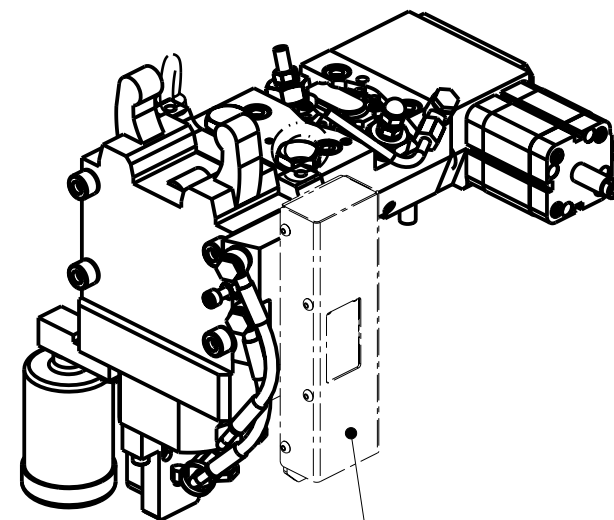
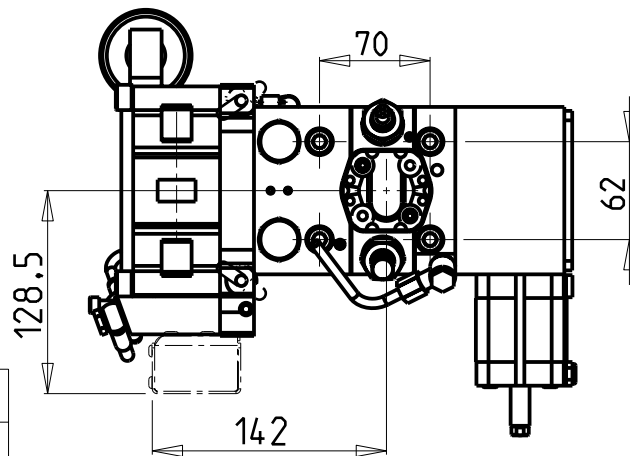
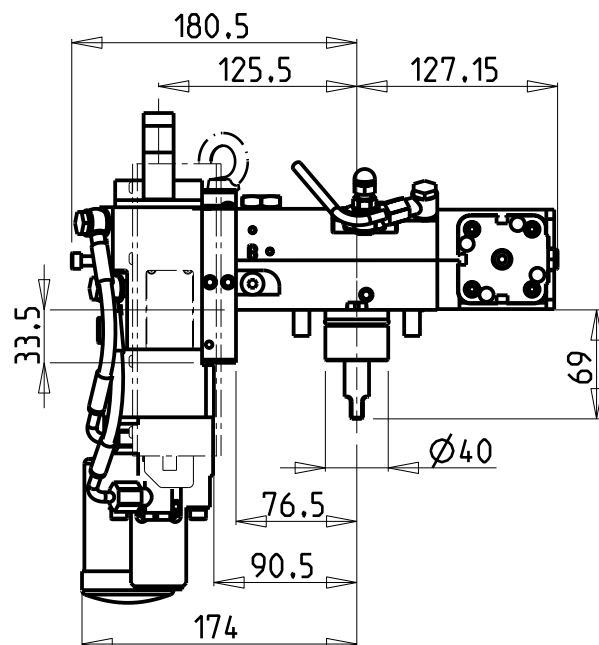
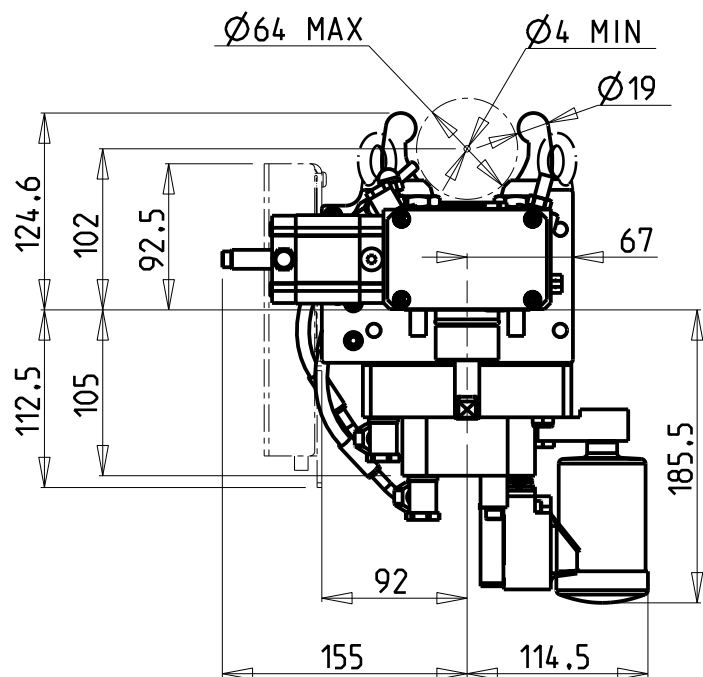

Only for
MNZ0310100JP

(())	#	CON GESTIONE ELETTRONICA APERTURA COMPLETA DELLA LUNETTA
	#	With Electronic control of steady rest arms complete opening
	#	Mit vollständiger elektronischer Öffnungsbedienung der Luenette

Cod. MT	I	RPM	Lubr. esterna Ext. coolant Aussenkuehlung	
MNZ0310100	1:1	6000	X	
# MNZ0310100EU	1:1	6000	X	EUROPE - AFRICA - MIDDLE EAST - NORTH ASIA
# MNZ0310100US	1:1	6000	X	USA - CANADA - MEXICO - AUSTRALIA - SOUTH ASIA
# MNZ0310100JP	1:1	6000	X	JAPAN

DMG-MORI
NZ1500/2000 - NZX1500/2000

MODULO MOTORIZZATO PER LUNETTA (TAGLIA 1)
Steady rest driven tool (Size 1)
Angetriebenes Werkzeug fuer Luenette (Grossse 1)

Subject to change without notice.

M.T. srl

Via Casino Albini 480
Tel. 0541/956034-957884
Fax 0541/956341
47842 S. GIOVANNI IN M. (RN)
e-mail: mtma@mtmarchetti.com
http://www.mtmarchetti.com



PAGINA MNZ361-1-00

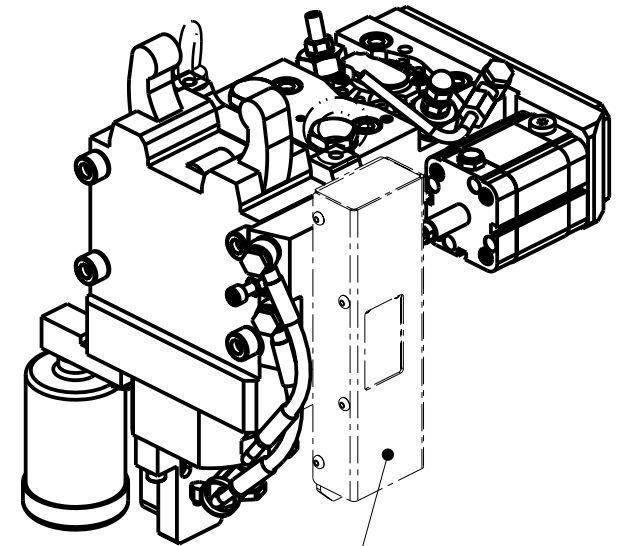
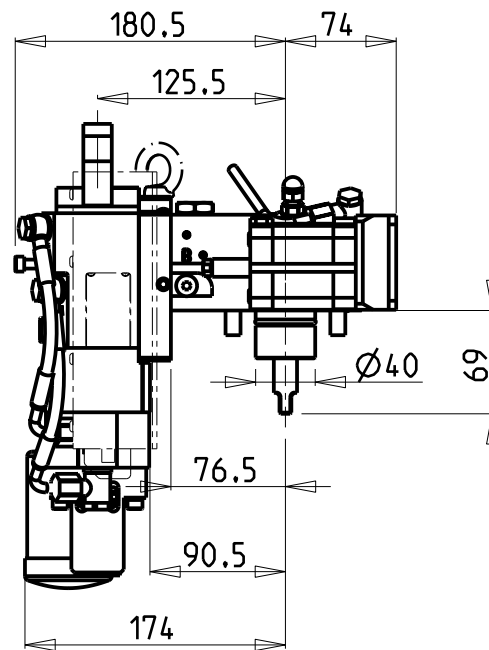
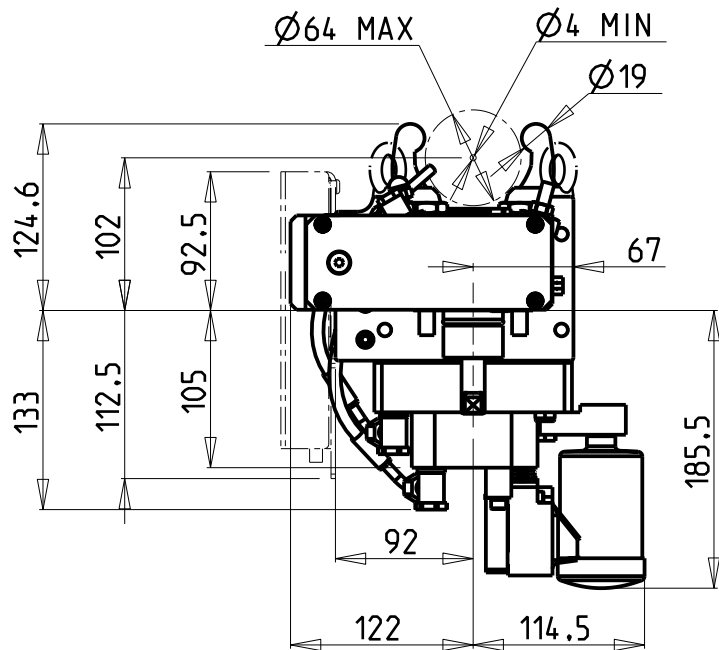

Only for
MNZ0310150JP

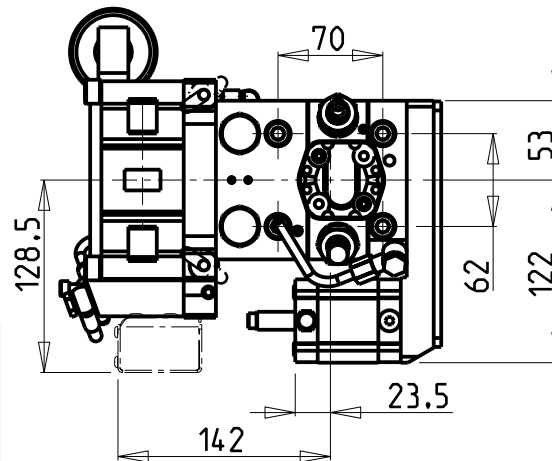

(())	#	CON GESTIONE ELETTRONICA APERTURA COMPLETA DELLA LUNETTA
	#	With Electronic control of steady rest arms complete opening
	#	Mit vollstaendiger elektronischer Oeffnungsbedienug der Luenette

Cod. MT	I	RPM	Lubr. esterna Ext. coolant Aussenkuehlung	
MNZ0310150	1:1	6000	X	
# MNZ0310150EU	1:1	6000	X	EUROPE - AFRICA - MIDDLE EAST - NORTH ASIA
# MNZ0310150US	1:1	6000	X	USA - CANADA - MEXICO - AUSTRALIA - SOUTH ASIA
# MNZ0310150JP	1:1	6000	X	JAPAN

DMG-MORI
NZ1500/2000 - NZX1500/2000 - NT3100/3150/3200 - NT1000/2000 - NTX1000/2000

MODULO MOTORIZZATO PER LUNETTA (TAGLIA 1)
Steady rest driven tool (Size 1)
Angetriebenes werkzeug fuer Luenette (Grosses 1)

Subject to change without notice.

M.T. srl
Via Casino Albini 480
Tel. 0541/956034-957884
Fax 0541/956341
47842 S. GIOVANNI IN M. (RN)
e-mail: mtma@mtmarchetti.com
http://www.mtmarchetti.com



PAGINA MNZ361-1-10

Ø64 MAX Ø4 MIN

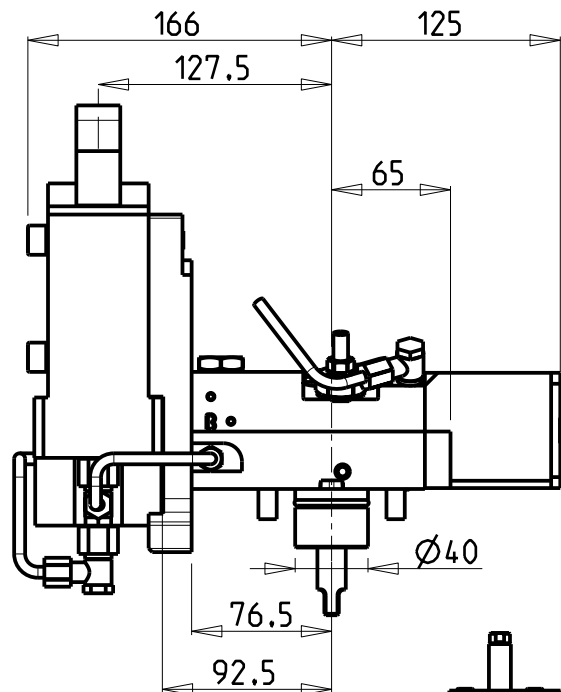
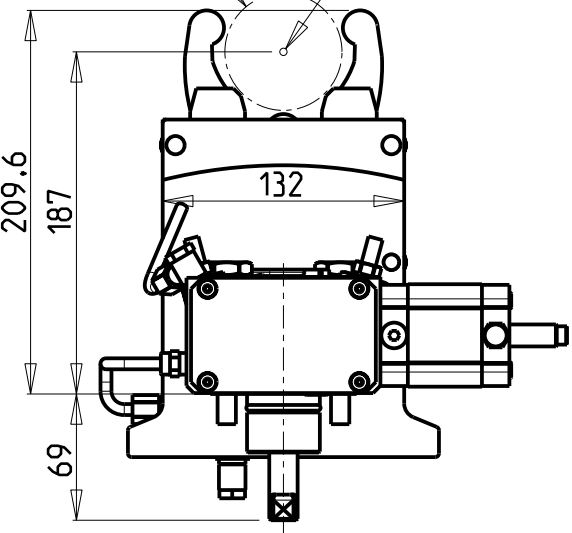

ATTENZIONE: SOLO PER TORRETTA "T2"
 WARNING: ONLY FOR "T2" TURRET
 ACHTUNG: NUR FUER REVOLVER "T2"

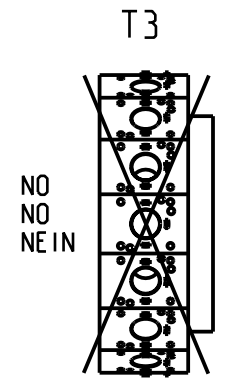
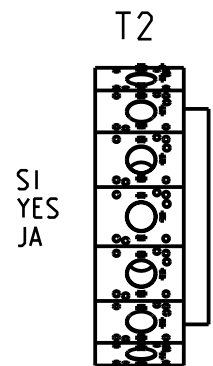
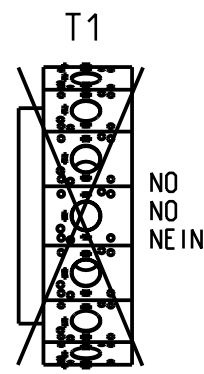

- # CON GESTIONE ELETTRONICA APERTURA COMPLETA DELLA LUNETTA
- # With Electronic control of steady rest arms complete opening
- # Mit vollstaendiger elektronischer Oeffnungsbedienug der Luenette

Cod. MT	I	RPM	Lubr.esterna Ext. coolant Aussenkuehlung
MNZ0310200	1:1	6000	X
MNZ0310200EU	1:1	6000	X
MNZ0310200US	1:1	6000	X

PER U.S.A.-AUSTRALIA-CANADA
 For U.S.A.-Australia-Canada
 Fuer U.S.A.-Australien-Kanada

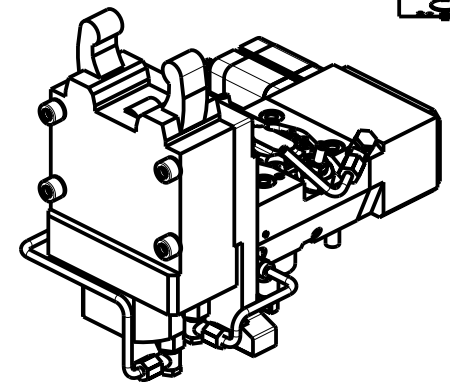
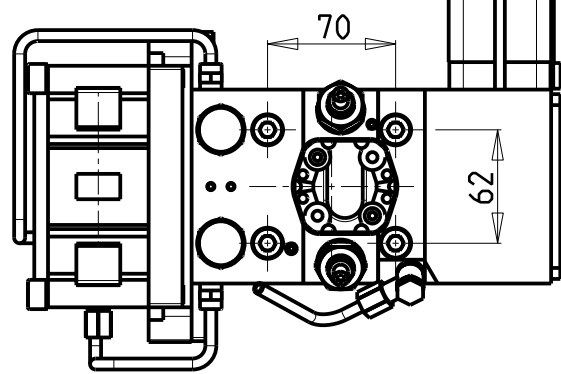

DMG-MORI
 NZ1500/2000

MODULO MOTORIZZATO PER LUNETTA RIALZATA (TAGLIA 1)
 Higher version steady rest driven tool (Size 1)
 Angetriebenes werkzeug fuer Luenette, hoehere Version (Grossse 1)

Subject to change without notice.

M.T. srl
 Via Casino Albini 480
 Tel. 0541/956034-957884
 Fax 0541/956341
 47842 S. GIOVANNI IN M. (RN)
 e-mail: mtma@mtmarchetti.com
 http://www.mtmarchetti.com



PAGINA MNZ362-1-00

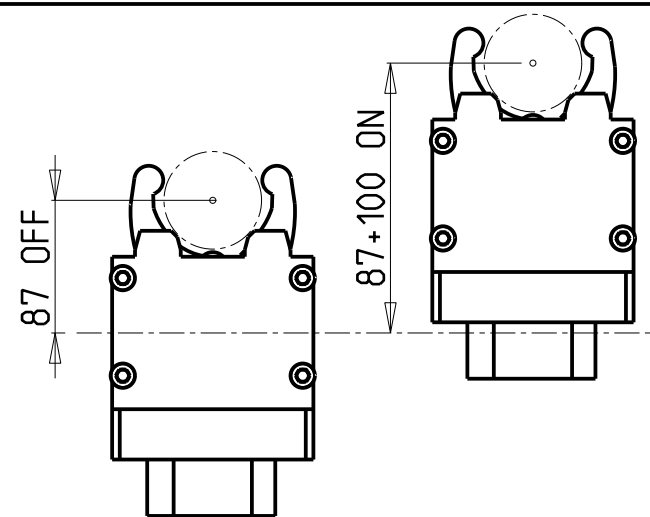
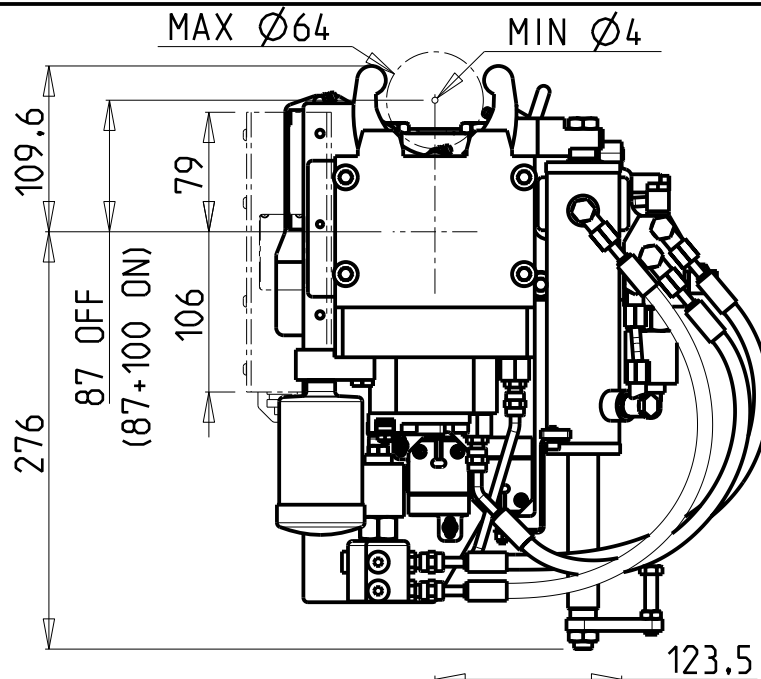
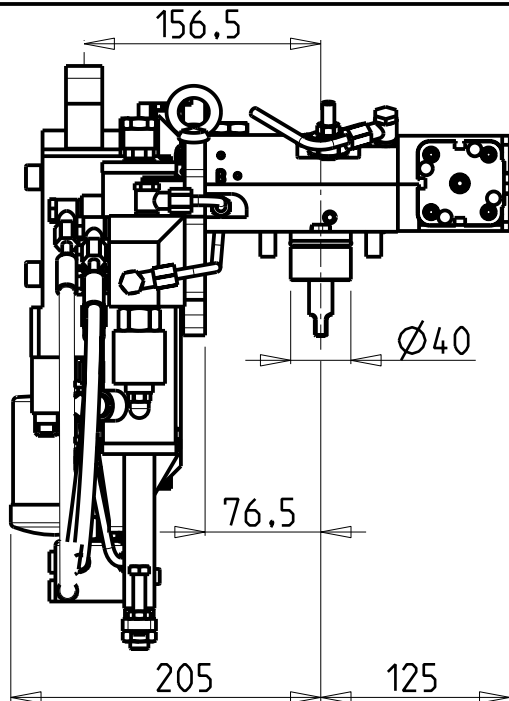

- # CON GESTIONE ELETTRONICA APERTURA COMPLETA DELLA LUNETTA
- # With Electronic control of steady rest arms complete opening
- # Mit vollständiger elektronischer Öffnungsbedienung der Luenette

Cod. MT	I	RPM	Lubr. esterna Ext. coolant Aussenkuehlung
MNZ0310300	1:1	6000	X
# MNZ0310300EU	1:1	6000	X
# MNZ0310300US	1:1	6000	X
# MNZ0310300JP	1:1	6000	X

EUROPE - AFRICA - MIDDLE EAST - NORTH ASIA

USA - CANADA - MEXICO - AUSTRALIA - SOUTH ASIA

JAPAN

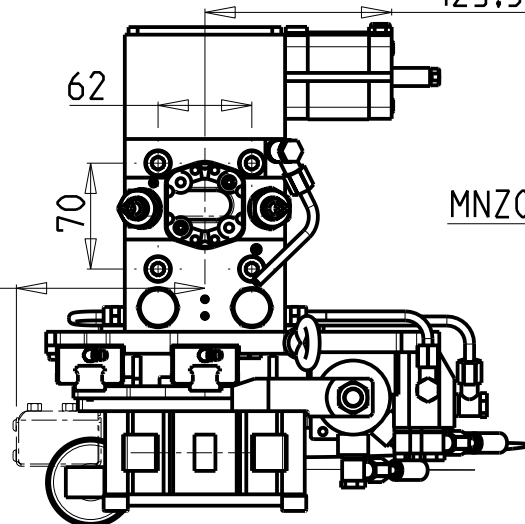

Only for MNZ0310300JP

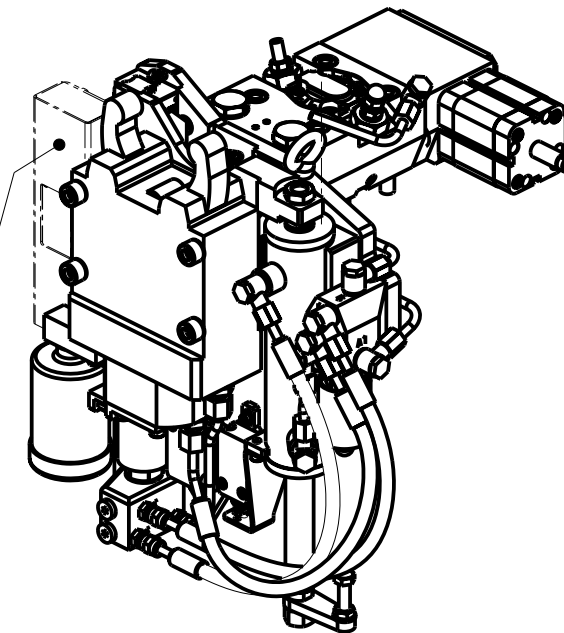

DMG-MORI
NZ1500/2000 - NZX1500/2000

MODULO MOTORIZZATO PER LUNETTA RETRATTILE (TAGLIA 1)
Driven toolholder for sliding steady rest (Size 1)
Luenettenwerkzeug zurueck versetzte Version (Grossse 1)

Subject to change without notice.

M.T. srl

Via Casino Albini 480
Tel. 0541/956034-957884
Fax 0541/956341
47842 S. GIOVANNI IN M. (RN)
e-mail: mtma@mtmarchetti.com
http://www.mtmarchetti.com



PAGINA MNZ363-1-00

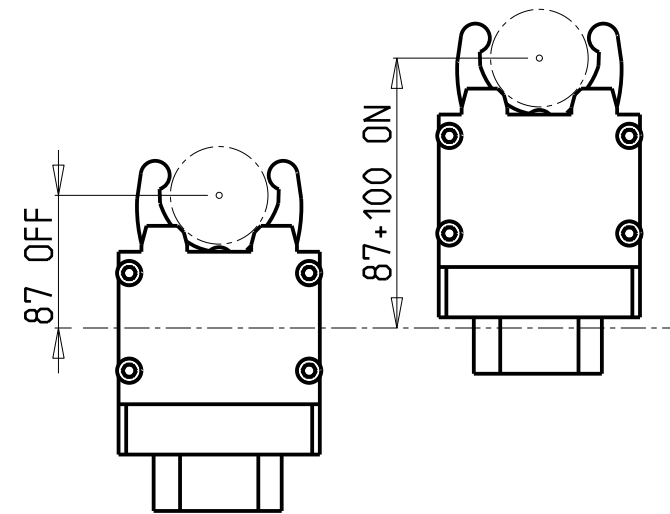
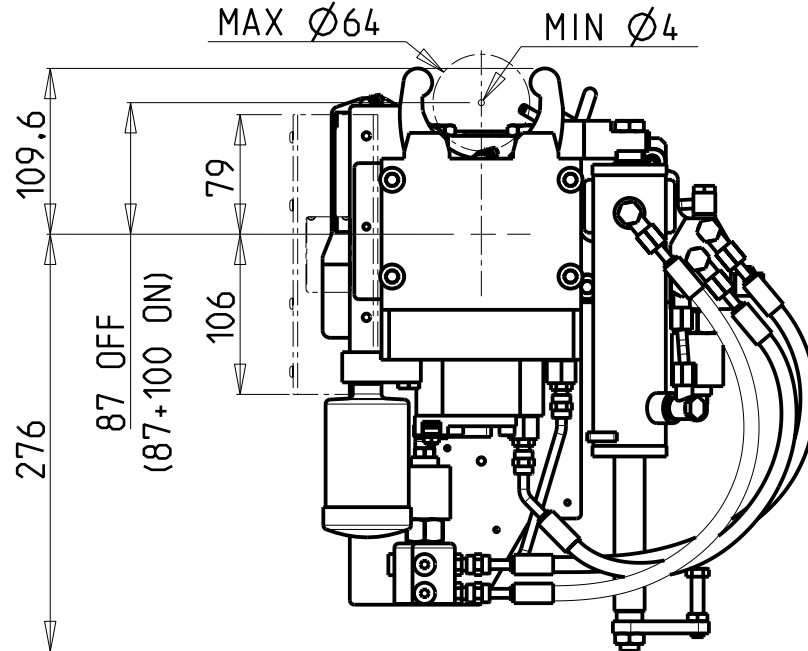
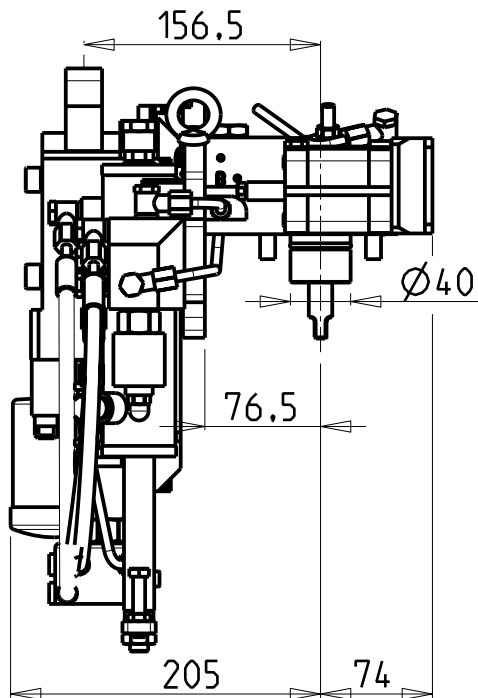

Only for
MNZ0310350JP

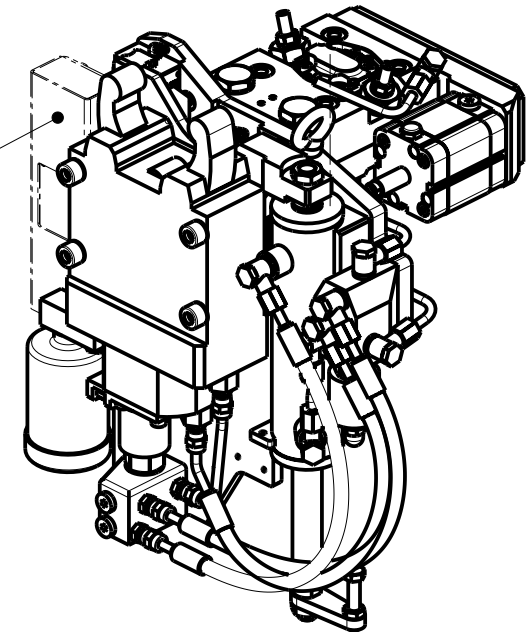

- # CON GESTIONE ELETTRONICA APERTURA COMPLETA DELLA LUNETTA
- # With Electronic control of steady rest arms complete opening
- # Mit vollständiger elektronischer Öffnungsbedienung der Luenette

Cod. MT	I	RPM	Lubr. esterna Ext. coolant Aussenkuehlung	
MNZ0310350	1:1	6000	X	
# MNZ0310350EU	1:1	6000	X	EUROPE - AFRICA - MIDDLE EAST - NORTH ASIA
# MNZ0310350US	1:1	6000	X	USA - CANADA - MEXICO - AUSTRALIA - SOUTH ASIA
# MNZ0310350JP	1:1	6000	X	JAPAN

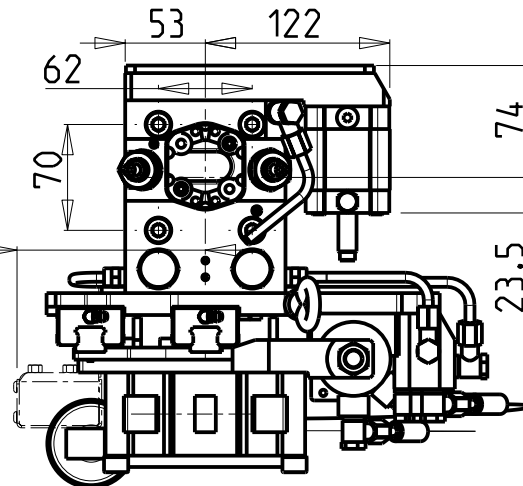

DMG-MORI
NZ1500/2000 - NZX1500/2000 - NT3100/3150/3200 - NT1000/2000 - NTX1000/2000

MODULO MOTORIZZATO PER LUNETTA RETRATTILE (TAGLIA 1)
Driven toolholder for sliding steady rest (Size 1)
Luenettenwerkzeug zurueck versetzte Version (Groesse 1)

Subject to change without notice.

M.T. srl

Via Casino Albini 480
Tel. 0541/956034-957884
Fax 0541/956341
47842 S. GIOVANNI IN M. (RN)
e-mail: mtma@mtmarchetti.com
http://www.mtmarchetti.com



PAGINA MNZ363-1-10

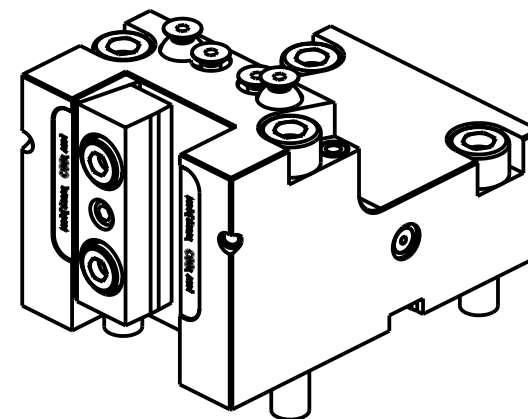
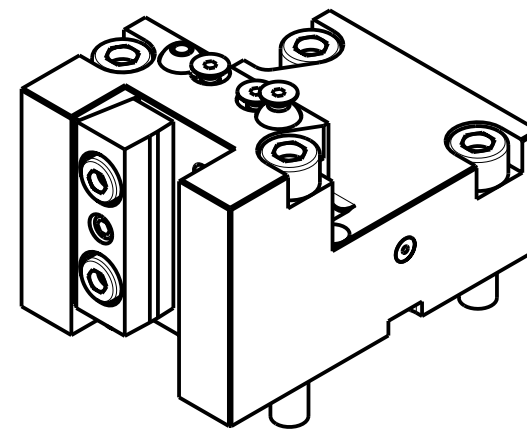
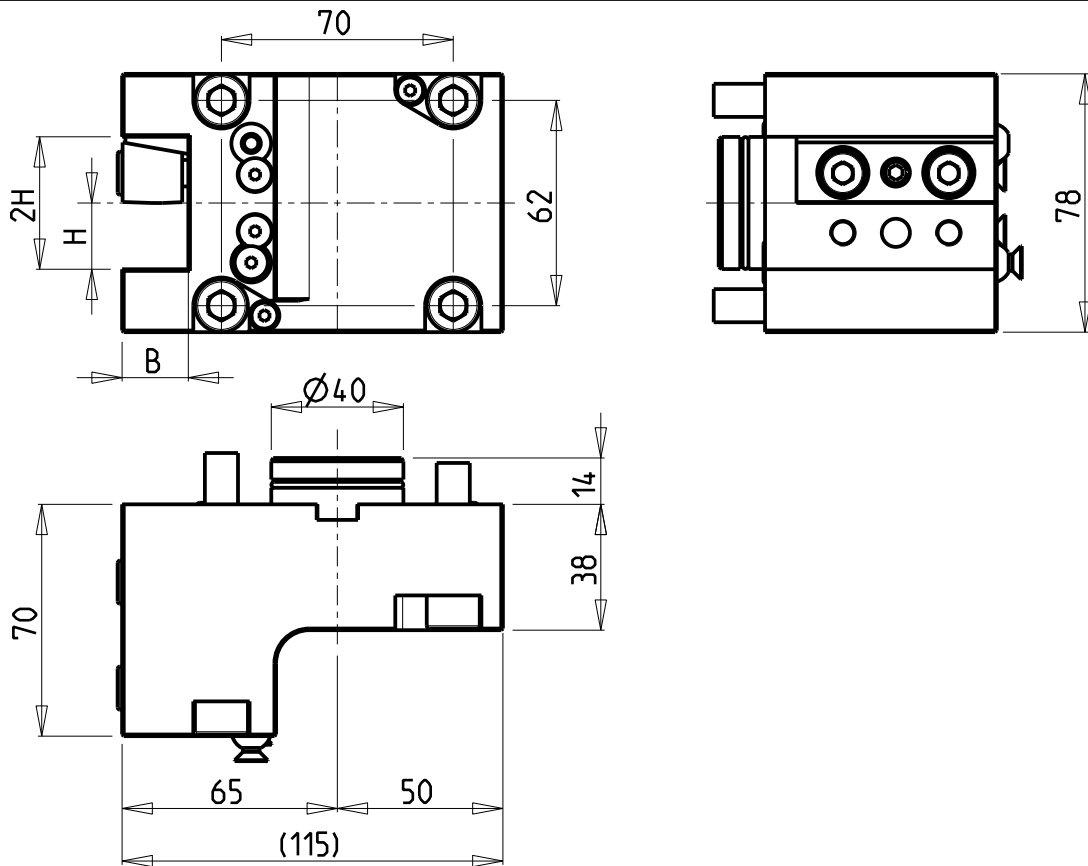

MNZ0092050

Cod. MT	N°Utensili N°Tools N°Werkzeuge	Reversibile lato mandrino/contromandrino Reversible sub/main spindle side Umkehrbare Spindel-seite/ Gegenspindel-seite	Lubrificazione int. Coolant through Innenkuehlung	Lubrificazione est. Ext. coolant Aussenkuehlung	Misure Dimensions Masse	B	H
MNZ0092000	1/2	X	-	X	mm	20	20
MNZ0092050	1/2	X	P=70bar	X	mm	20	20
MNZ0091905	1/2	X	-	X	Inch	3/4"	3/4"

DMG-MORI

NZ1500/2000 - NZX1500/2000 - NZX2500 (BMT40) - NT3100/3150/3200 - NL1500/2000/2500 20 STAZ. - NLX1500/2000/2500 20 STAZ. - NT1000/2000
NTX1000/2000 - NTX1000/2000/2500/3000 2ND GEN. 12ST. - DURATURN 2050MC/2550MC - NRX2000 - ALX1500/2000/2500 - ECOTURN 450 (BMT40)

PORTAUTENSILE RADIALE SINGOLO QD=20mm / QD=3/4" H=70mm

Radial single static tool QD=20mm / QD=3/4" H=70mm

Radial Single-Werkzeughalter QD=20mm / QD=3/4" H=70mm

Subject to change without notice.

M.T. srl

Via Casino Albini 480

Tel. 0541/956034-957884

Fax 0541/956341

47842 S. GIOVANNI IN M. (RN)

e-mail: mtma@mtmarchetti.com

http://www.mtmarchetti.com



PAGINA MNZ420-1-00

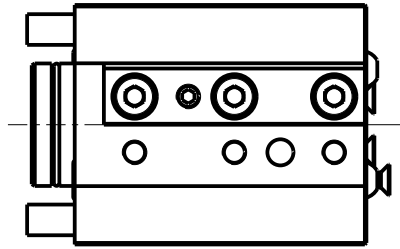
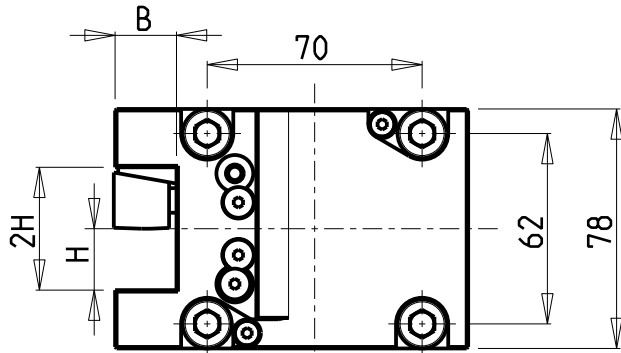

MNZ0092060

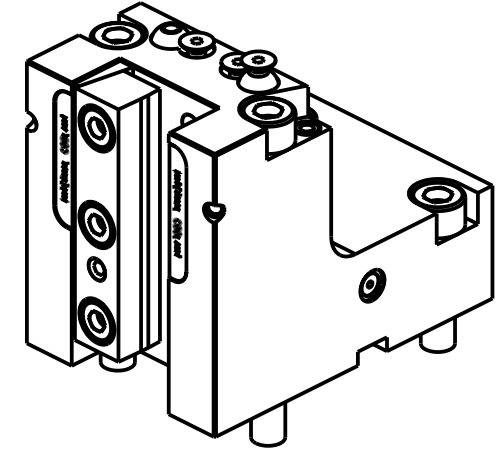
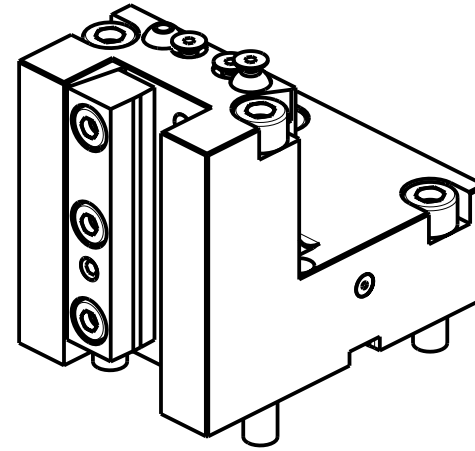
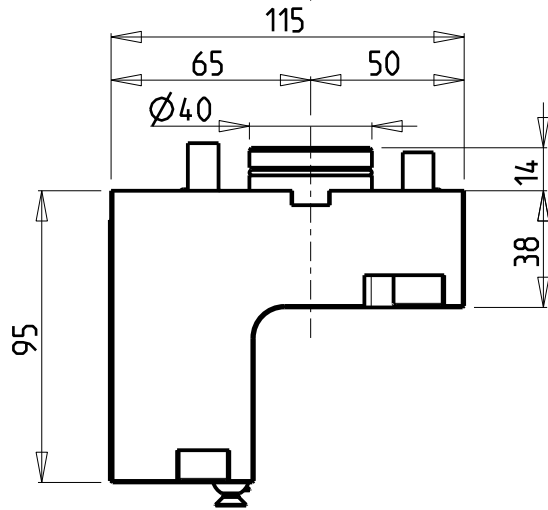

Cod. MT	N°Utensili N°Tools N°Werkzeuge	Reversibile lato mandrino/contromandrino Reversible sub/main spindle side Umkehrbare Spindel-seite/ Gegenspindel-seite	Lubrificazione int. Coolant through Innenkuehlung	Lubrificazione est. Ext. coolant Aussenkuehlung	Misure Dimensions Masse	B	H
MNZ0092010	1	X	-	X	mm	20	20
MNZ0092060	1	X	P=70bar	X	mm	20	20
MNZ0091915	1	X	-	X	Inch	3/4"	3/4"

NEW

DMG-MORI
 NZ1500/2000 - NZX1500/2000 - NZX2500 (BMT40) - NT3100/3150/3200 - NL1500/2000/2500 20 STAZ. - NLX1500/2000/2500 20 STAZ. - NT1000/2000
 NTX1000/2000 - NTX1000/2000/2500/3000 2ND GEN. 12ST. - DURATURN 2050MC/2550MC - NRX2000 - ALX1500/2000/2500 - ECOTURN 450 (BMT40)

PORTAUTENSILE RADIALE SINGOLO QD=20mm / QD=3/4" H=95mm
 Radial single static tool QD=20mm / QD=3/4" H=95mm
 Radial Single-Werkzeughalter QD=20mm / QD=3/4" H=95mm

M.T. srl
 Via Casino Albini 480
 Tel. 0541/956034-957884
 Fax 0541/956341
 47842 S. GIOVANNI IN M. (RN)
 e-mail: mtma@tmarchetti.com
 http://www.tmmarchetti.com



PAGINA MNZ420-1-10

Subject to change without notice.

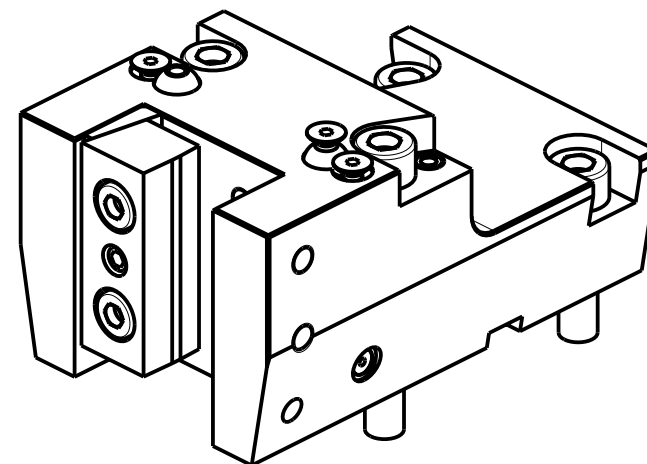
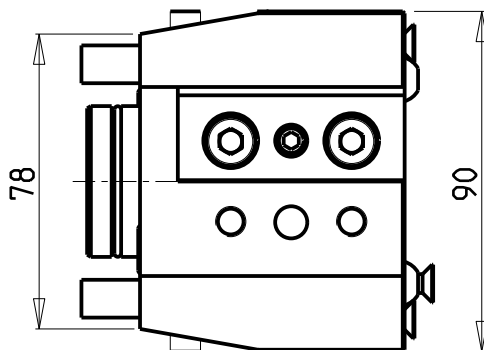
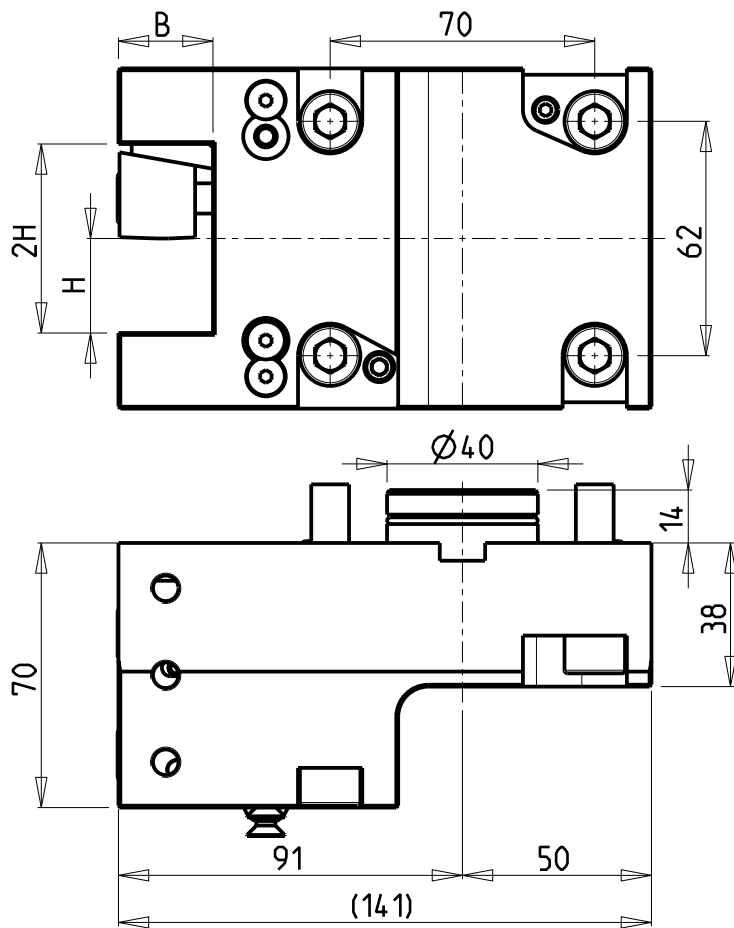

Cod. MT	N°Utensili N°Tools N°Werkzeuge	Reversibile lato mandrino/contromandrino Reversible sub/main spindle side Umkehrbare Spindel-seite/ Gegenspindel-seite	Misure Dimensions Masse	B	H
MNZ0092500	1	X	mm	25	25
MNZ0092540	1	X	Inch	1"	1"

DMG-MORI

NZ1500/2000 - NZX1500/2000 - NZX2500 (BMT40) - NT3100/3150/3200 - NL1500/2000/2500 20 STAZ. - NLX1500/2000/2500 20 STAZ. - NT1000/2000
NTX1000/2000 - NTX1000/2000/2500/3000 2ND GEN. 12ST. - DURATURN 2050MC/2550MC - NRX2000 - ALX1500/2000/2500 - ECOTURN 450 (BMT40)

PORTAUTENSILE RADIALE SINGOLO QD=25mm / QD=1" H=70mm

Radial single static tool QD=25mm / QD=1" H=70mm

Radial Single-Werkzeughalter QD=25mm / QD=1" H=70mm

Subject to change without notice.

M.T. srl

Via Casino Albini 480
Tel. 0541/956034-957884
Fax 0541/956341

47842 S. GIOVANNI IN M. (RN)
e-mail: mtma@mtmarchetti.com
http://www.mtmarchetti.com



PAGINA MNZ423-1-00

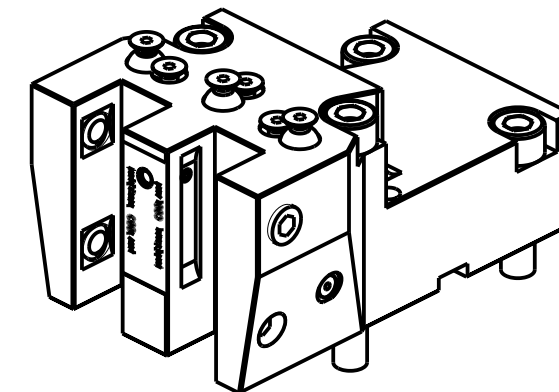
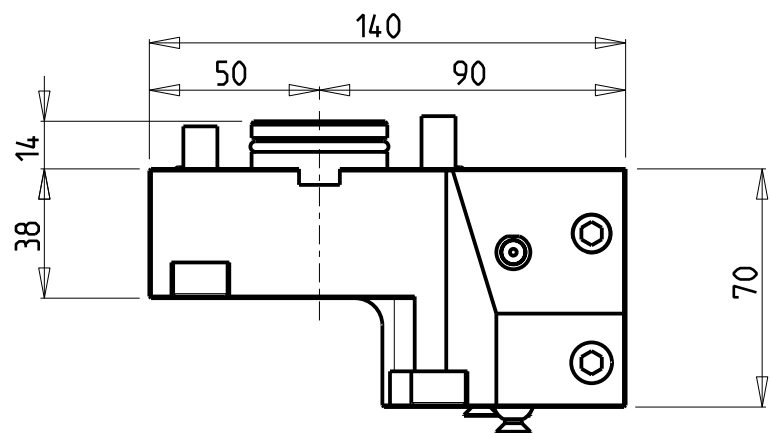
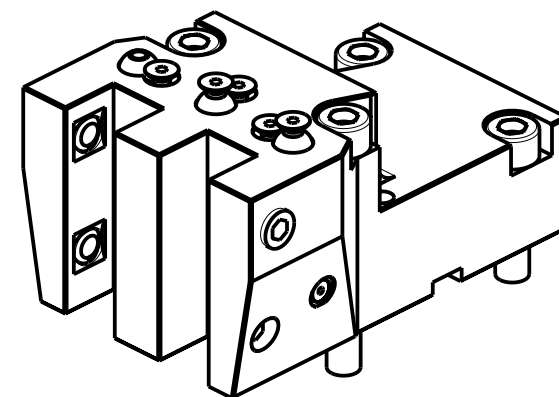
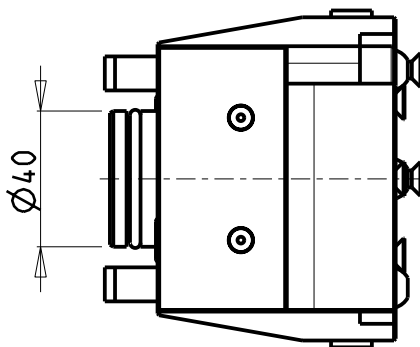
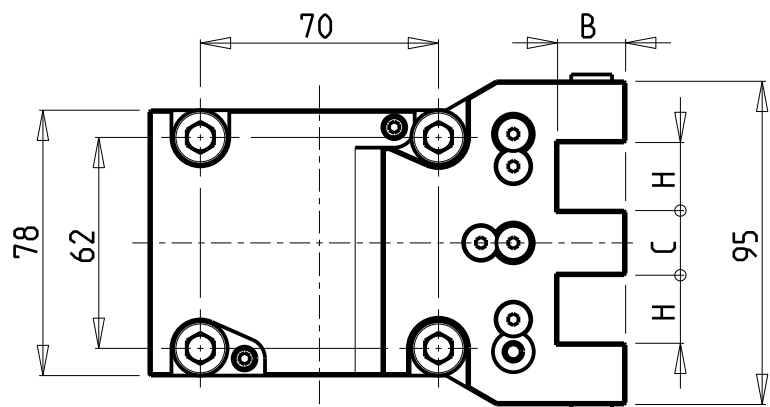

MNZ0102050

Cod. MT	N°Utensili N°Tools N°Werkzeuge	Reversibile lato mandrino/contromandrino Reversible sub/main spindle side Umkehrbare Spindel-seite/ Gegenspindel-seite	Lubrificazione int. Coolant through Innenkuehlung	Lubrificazione est. Ext. coolant Aussenkuehlung	Misure Dimensions Masse	B	H	C
MNZ0102000	2	X	-	X	mm	20	20	19
MNZ0102050	2	X	P=70bar	X	mm	20	20	19
MNZ0101905	2	X	-	X	Inch	3/4"	3/4"	0.822"

DMG-MORI

NZ1500/2000 - NZX1500/2000 - NT3100/3150/3200 - NL1500/2000/2500 20 STAZ. - NLX1500/2000/2500 20 STAZ. - NT1000/2000
 NTX1000/2000 - NTX1000/2000/2500/3000 2ND GEN. 12ST. - DURATURN 2050MC/2550MC - ALX1500/2000/2500 - ECOTURN 450 (BMT40)

PORTAUTENSILE RADIALE SOVRAPPOSTO QD=20mm / QD=3/4" H=70mm

Radial single side twin static tool QD=20mm / QD=3/4" H=70mm

Radial Werkzeughalter ueberlagert QD=20mm / QD=3/4" H=70mm

Subject to change without notice.

M.T. srl

Via Casino Albini 480
 Tel. 0541/956034-957884
 Fax 0541/956341
 47842 S. GIOVANNI IN M. (RN)
 e-mail: mtma@tmarchetti.com
 http://www.tmmarchetti.com



PAGINA MNZ440-1-00

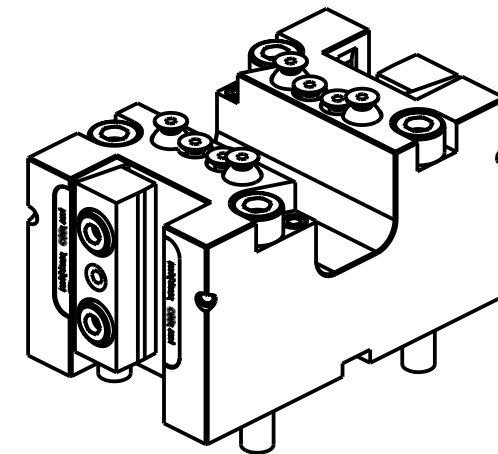
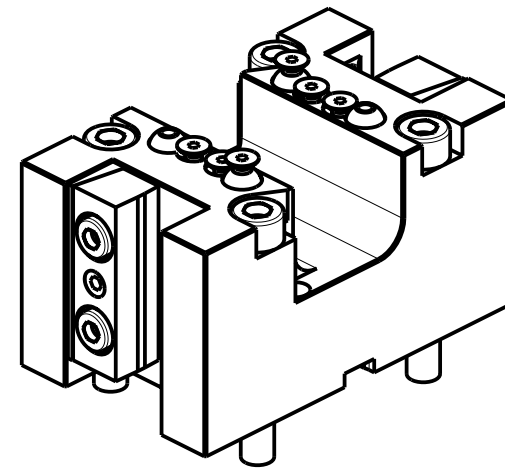
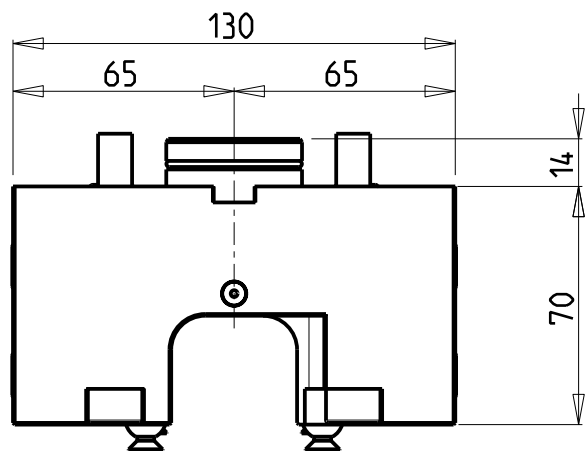
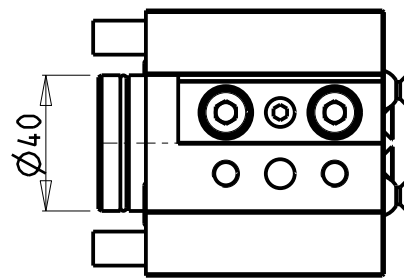
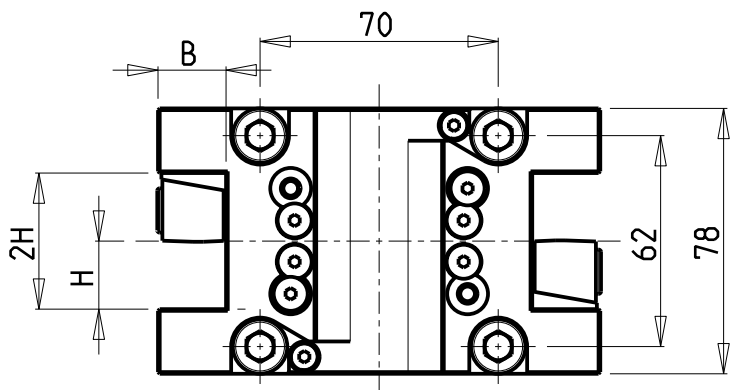

MNZ0112050

Cod. MT	N°Utensili N°Tools N°Werkzeuge	Reversibile lato mandrino/contromandrino Reversible sub/main spindle side Umkehrbare Spindel-seite/ Gegenspindel-seite	Lubrificazione int. Coolant through Innenkuehlung	Lubrificazione est. Ext. coolant Aussenkuehlung	Misure Dimensions Masse	B	H
MNZ0112000	2/4	X	-	X	mm	20	20
MNZ0112050	2/4	X	P=70bar	X	mm	20	20
MNZ0111905	2/4	X	-	X	Inch	3/4"	3/4"

DMG-MORI

NZ1500/2000 - NZX1500/2000 - NZX2500 (BMT40) - NT3100/3150/3200 - NL1500/2000/2500 20 STAZ. - NLX1500/2000/2500 20 STAZ. - NT1000/2000
NTX1000/2000 - NTX1000/2000/2500/3000 2ND GEN. 12ST. - DURATURN 2050MC/2550MC - ALX1500/2000/2500 - ECOTURN 450 (BMT40)

PORTAUTENSILE RADIALE DOPPIO QD=20mm / QD=3/4" H=70mm

Radial double static tool QD=20mm / QD=3/4" H=70mm

Radial Doppel-Werkzeughalter QD=20mm / QD=3/4" H=70mm

Subject to change without notice.

M.T. srl

Via Casino Albini 480
Tel. 0541/956034-957884

Fax 0541/956341

47842 S. GIOVANNI IN M. (RN)

e-mail: mtma@mtmarchetti.com

http://www.mtmarchetti.com



PAGINA MNZ450-1-00

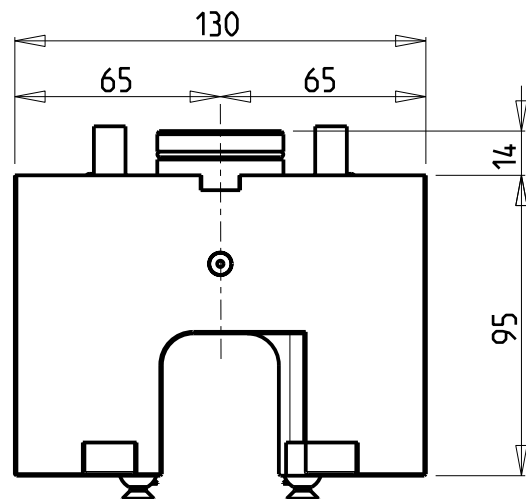
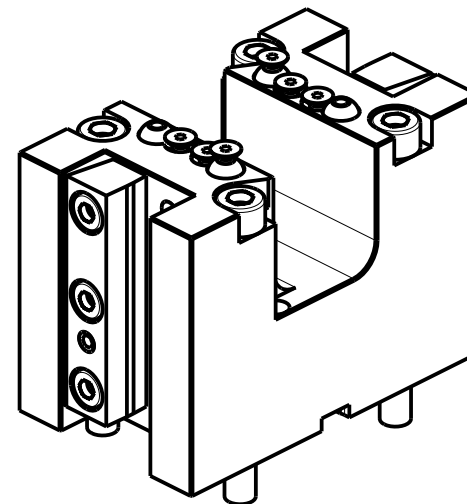
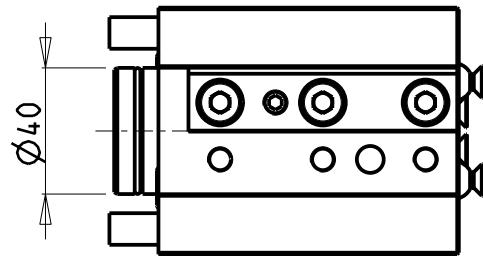
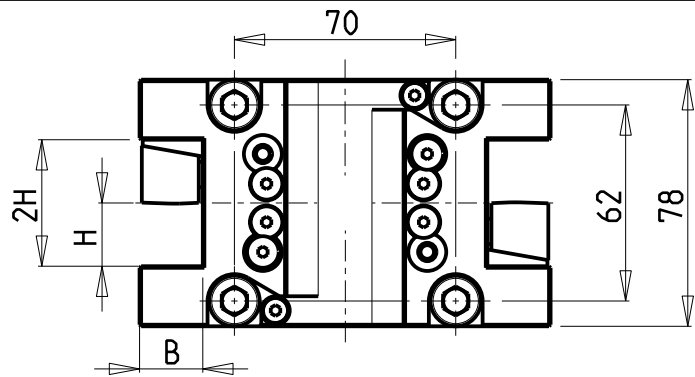

MNZ0112060

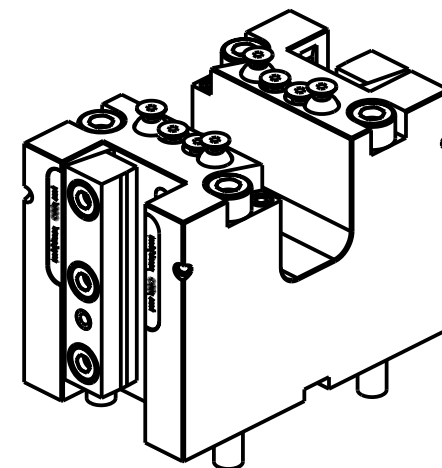

Cod. MT	N°Utensili N°Tools N°Werkzeuge	Reversibile lato mandrino/contromandrino Reversible sub/main spindle side Umkehrbare Spindel-seite/ Gegenspindel-seite	Lubrificazione int. Coolant through Innenkuehlung	Lubrificazione est. Ext. coolant Aussenkuehlung	Misure Dimensions Masse	B	H
MNZ0112010	2	X	-	X	mm	20	20
MNZ0111915	2	X	-	X	Inch	3/4"	3/4"
MNZ0112060	2	X	P=70bar	X	mm	20	20

DMG-MORI

NZ1500/2000 - NZX1500/2000 - NZX2500 (BMT40) - NT3100/3150/3200 - NL1500/2000/2500 20 STAZ. - NLX1500/2000/2500 20 STAZ. - NT1000/2000
NTX1000/2000 - NTX1000/2000/2500/3000 2ND GEN. 12ST. - DURATURN 2050MC/2550MC - ALX1500/2000/2500 - ECOTURN 450 (BMT40)

PORTAUTENSILE RADIALE DOPPIO QD=20mm / QD=3/4" H=95mm

Radial double static tool QD=20mm / QD=3/4" H=95mm

Radial Doppel-Werkzeughalter QD=20mm / QD=3/4" H=95mm

Subject to change without notice.

M.T. srl

Via Casino Albini 480
Tel. 0541/956034-957884
Fax 0541/956341

47842 S. GIOVANNI IN M. (RN)
e-mail: mtma@tmarchetti.com
http://www.tmmarchetti.com



PAGINA MNZ450-1-10

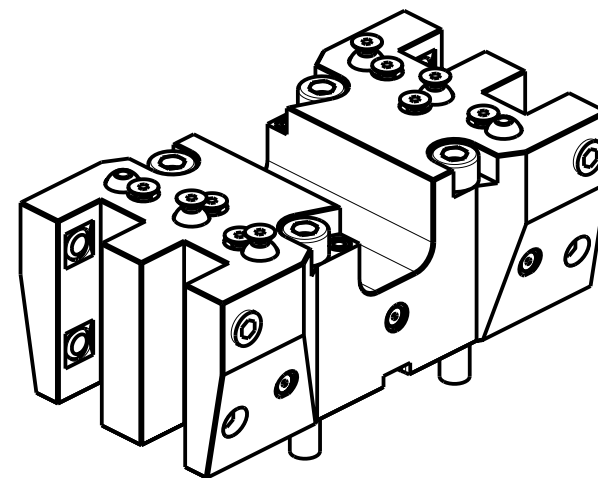
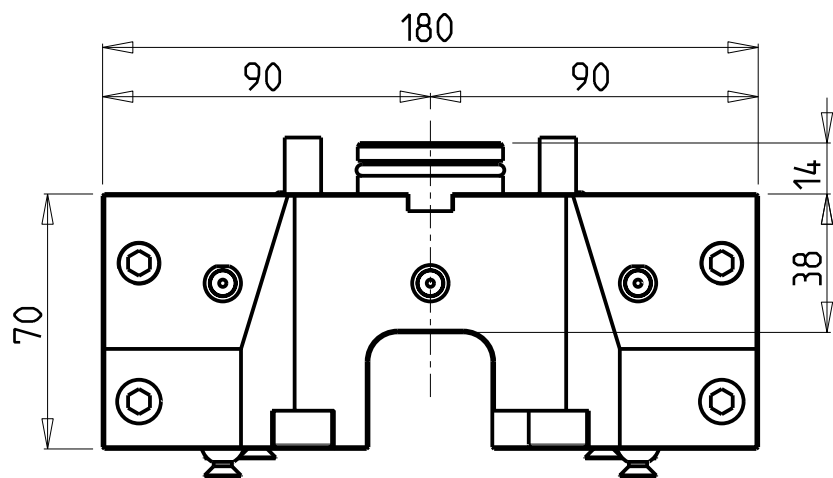
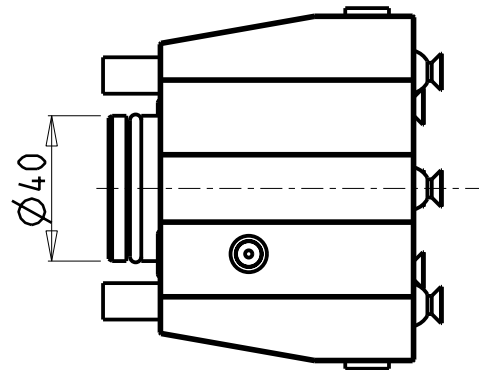
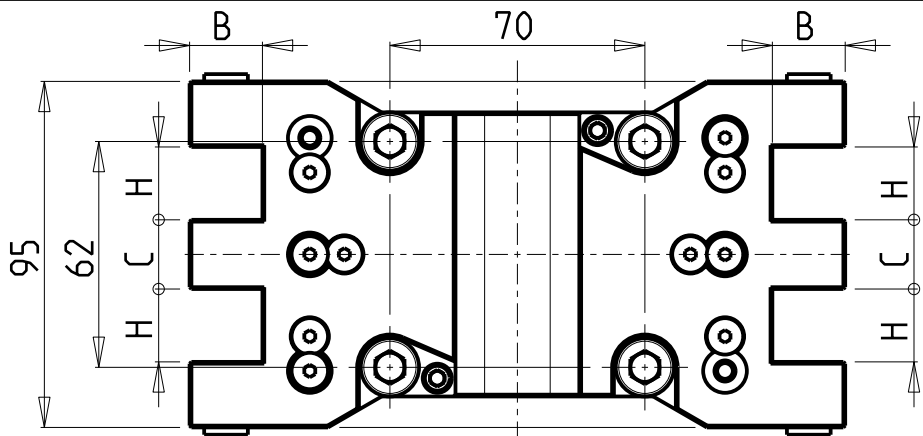

Cod. MT	N°Utensili N°Tools N°Werkzeuge	Reversibile lato mandrino/contromandrino Reversible sub/main spindle side Umkehrbare Spindel-seite/ Gegenspindel-seite	Misure Dimensions Masse	B	H	C
MNZ0122000	4	X	mm	20	20	19
MNZ0121905	4	X	Inch	3/4"	3/4"	0.822"

DMG-MORI

NZ1500/2000 - NZX1500/2000 - NT3100/3150/3200 - NL1500/2000/2500 20 STAZ. - NLX1500/2000/2500 20 STAZ.
NT1000/2000 - NTX1000/2000 - DURATURN 2050MC/2550MC - ALX1500/2000/2500

PORTAUTENSILE RADIALE DOPPIO SOVRAPPOSTO QD=20mm / QD=3/4" H=70mm

Radial double side twin static tool QD=20mm / QD=3/4" H=70mm

Radial Doppel-Werkzeughalter ueberlagert QD=20mm / QD=3/4" H=70mm

M.T. srl

Via Casino Albini 480
Tel. 0541/956034-957884
Fax 0541/956341

47842 S. GIOVANNI IN M. (RN)
e-mail: mtma@mtmarchetti.com
http://www.mtmarchetti.com



PAGINA MNZ460-1-00

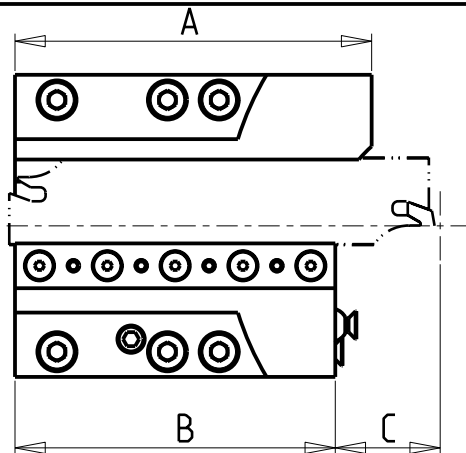
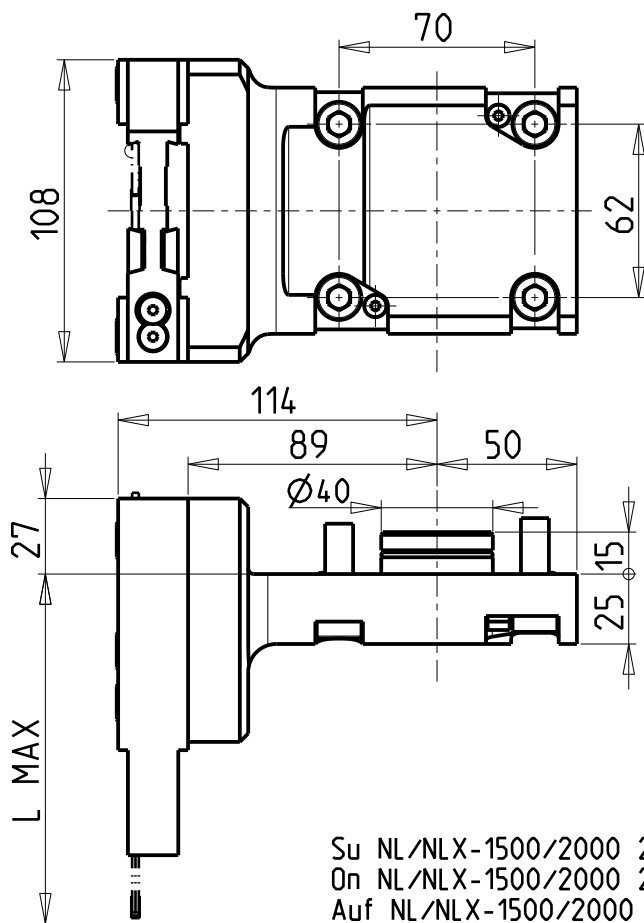

POSSIBILITA' DI LAVORO M3/M4
 OPTION OF M3/M4 WORKING
 ARBEITSMOGLICHKEIT M3/M4

Su NL/NLX-1500/2000 20 stazioni il portautensile cod. MNZ0180132 è fuori volteggio
 On NL/NLX-1500/2000 20 st. the blade holder cod. MNZ0180132 is out of rotation
 Auf NL/NLX-1500/2000 20 st. ist das Abstechhalter cod. MNZ0180132 ausser Raumbedarf

DOTAZIONI - SUPPLIED WITH - AUSSTATTUNG

- N°1 - LAMA - BLADE - KLINGE ISCAR H=32 Sp. 3/4mm (KENNAMETAL OPTIONAL)
- N°10 - INSERTI - INSERTS - EINLAGEN
- N°1 - CHIAVE A T PER MONTAGGIO INSERTI
 - T-WRENCH FOR INSERT SET UP
 - T-SCHLUESSEL FUER EINSATZSTUECK-MONTAGE

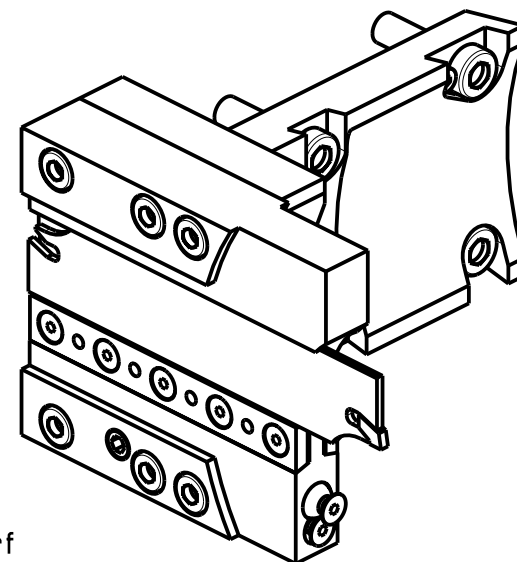

Cod. MT	N°Utensili N°Tools N°Werkzeuge	Reversibile lato mandrino/contromandrino Reversible sub/main spindle side Umkehrbare Spindelseite/ Gegenspindelseite	A	B	C	L MAX
MNZ0180132	1	X	127.5	113	39	125
MNZ0180232	1	X	114.5	100	52	115

DMG-MORI

NZ1500/2000 - NZX1500/2000 - NZX2500 (BMT40) - NT3100/3150/3200 - NL1500/2000/2500 20 STAZ. - NLX1500/2000/2500 20 STAZ. - NT1000/2000
 NTX1000/2000/2500/3000 2ND GEN. 12ST. - DURATURN 2050MC/2550MC - NRX2000 - ALX1500/2000/2500 - ECOTURN 450 (BMT40)

PORTAUTENSILE PER LAMA DOPPIO

Radial double blade holder

Radial Doppel Abstechhalter

Subject to change without notice.

M.T. srl

Via Casino Albini 480
 Tel. 0541/956034-957884
 Fax 0541/956341
 47842 S. GIOVANNI IN M. (RN)
 e-mail: mtma@mtmarchetti.com
 http://www.mtmarchetti.com



PAGINA MNZ520-1-00

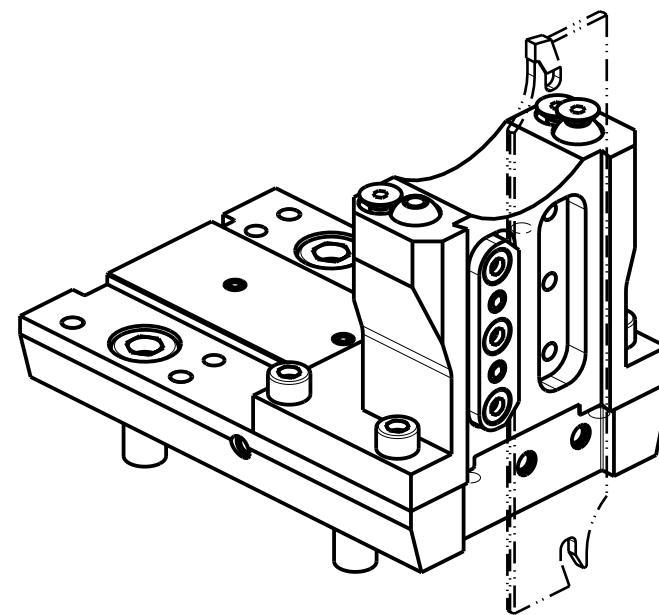
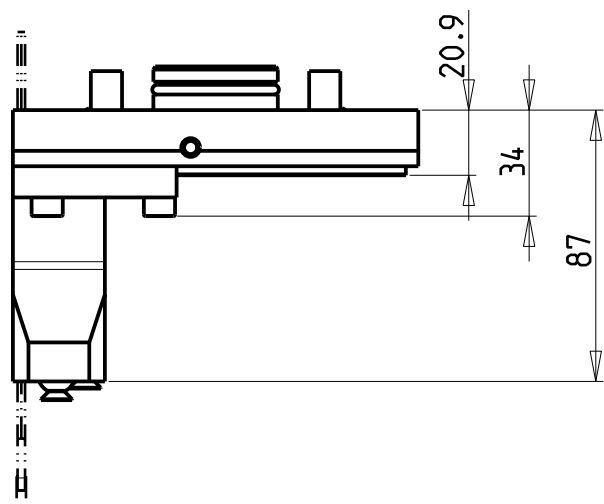
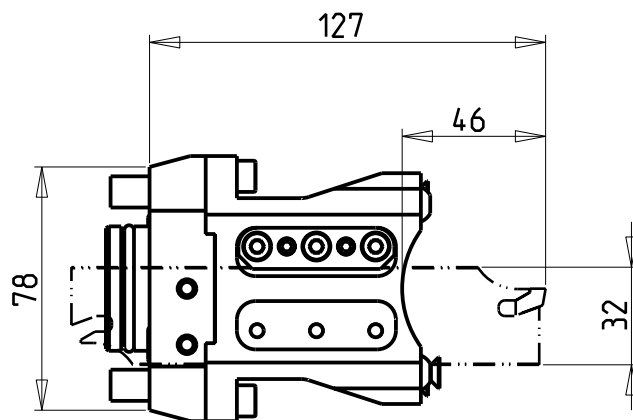
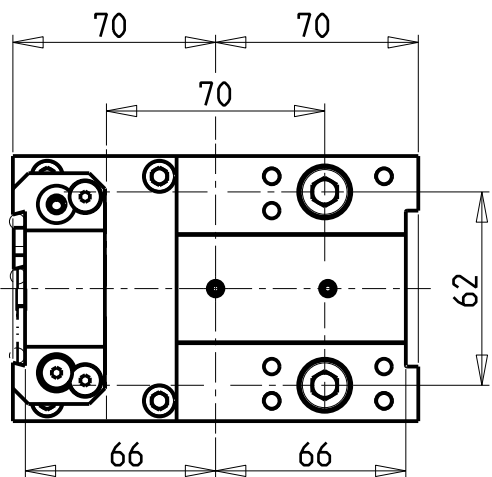

POSSIBILITA' DI LAVORO M3/M4
 OPTION OF M3/M4 WORKING
 ARBEITSMÖGLICHKEIT M3/M4

DOTAZIONI - SUPPLIED WITH - AUSSTATTUNG

N°1 - LAMA - BLADE - KLINGE ISCAR H=32 Sp. 3/4mm
 (KENNAMETAL OPTIONAL)

N°10 - INSERTI - INSERTS - EINLAGEN

N°1 - CHIAVE A T PER MONTAGGIO INSERTI
 - T-WRENCH FOR INSERT SET UP
 - T-SCHLUESSEL FUER EINSATZSTUECK-MONTAGE

Cod. MT	N°Utensili N°Tools N°Werkzeuge	Reversibile lato mandrino/contromandrino Reversible sub/main spindle side Umkehrbare Spindel-seite/ Gegenspindel-seite	Lubr.esterna Ext. coolant Aussehenkuehlung
MNZ0380132	1	X	X

DMG-MORI

NZ1500/2000 - NZX1500/2000 - NZX2500 (BMT40) - NT3100/3150/3200 - NL1500/2000/2500 20 STAZ. - NLX1500/2000/2500 20 STAZ. - NT1000/2000
 NTX1000/2000/2500/3000 2ND GEN. 12ST. - DURATURN 2050MC/2550MC - NRX2000 - ALX1500/2000/2500 - ECOTURN 450 (BMT40)

PORTAUTENSILE RADIALE PER LAMA

Radial blade holder

Radial Abstechhalter

Subject to change without notice.

M.T. srl

Via Casino Albini 480
 Tel. 0541/956034-957884
 Fax 0541/956341
 47842 S. GIOVANNI IN M. (RN)
 e-mail: mtma@mtmarchetti.com
 http://www.mtmarchetti.com



PAGINA MNZ520-1-01

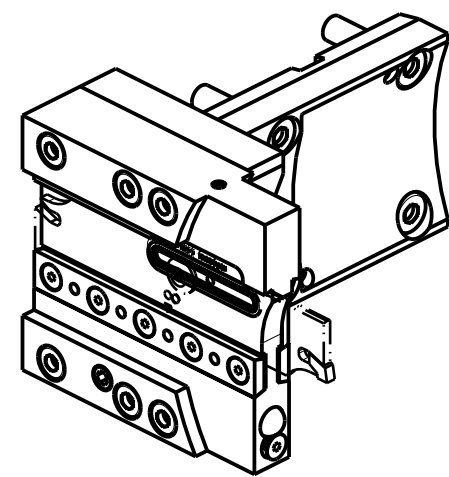
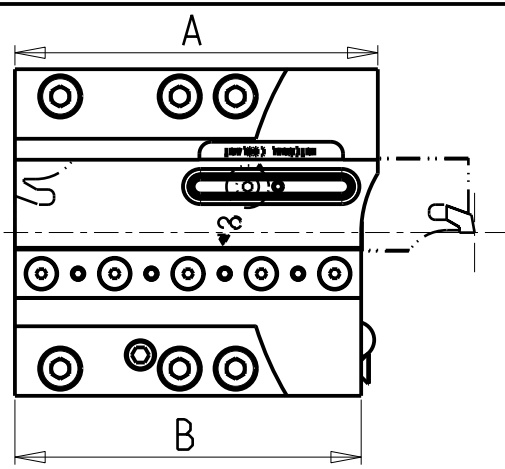
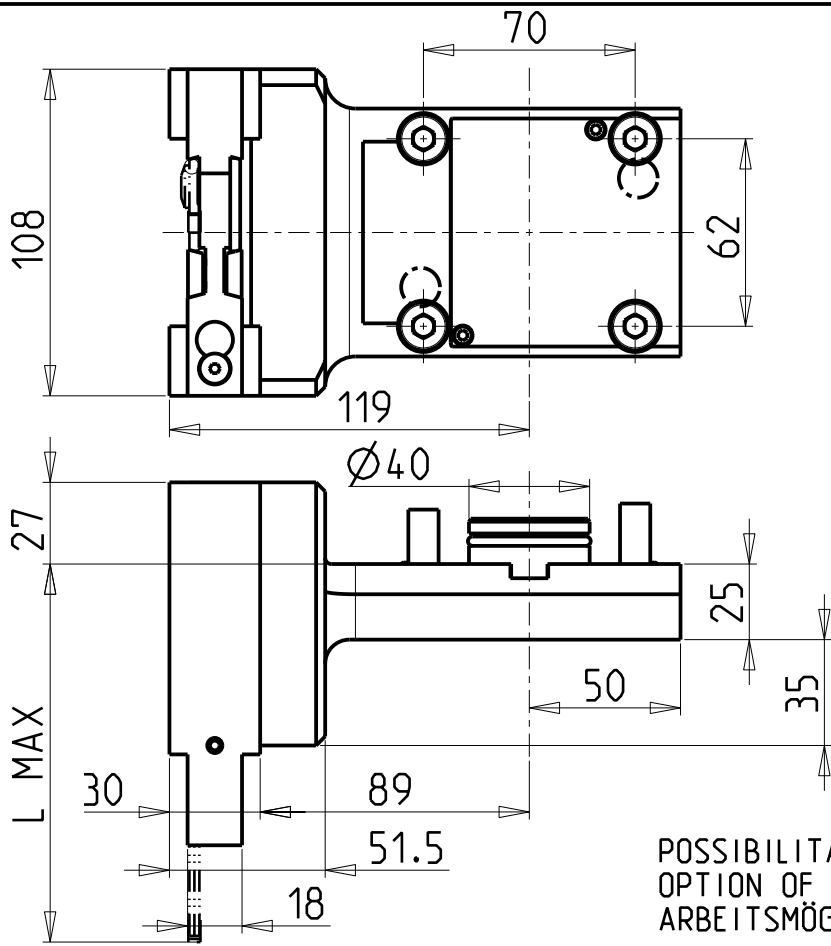

Su NL/NLX-1500/2000 20 stazioni il portautensile cod. MNZ0520132 è fuori rotazione
 On NL/NLX-1500/2000 20 st. the blade holder cod. MNZ0520132 is out of rotation
 Auf NL/NLX-1500/2000 20 st. ist das Abstechhalter cod. MNZ0520132 ausser Raumbedarf

POSSIBILITA' DI LAVORO M3/M4
 OPTION OF M3/M4 WORKING
 ARBEITSMÖGLICHKEIT M3/M4

- KIT LAME NON INCLUSI (OPZIONALI)**
BLADES NOT SUPPLIED WITH (OPTIONAL)
KLINGEN NICHT INBEGRIFFEN (OPTIONAL)
- LAMA-BLADE-KLINGE SANDVIK H=32 sp.3 cod. QD_NN2G60C25A
 +INSERTI-INSERTS-EINLAGEN cod. QD_NG_0300_0002_CM_1145 (10 pz.)
 - LAMA-BLADE-KLINGE SANDVIK H=32 sp.4 cod. QD_NN2H60C25A
 +INSERTI-INSERTS-EINLAGEN cod. QD_NH_0400_0002_CM_1145 (10 pz.)
 - LAMA-BLADE-KLINGE ISCAR H=32 sp.3 cod. SGFH_32K_3
 +INSERTI-INSERTS-EINLAGEN cod. 6011365 (10pz.)
 - LAMA-BLADE-KLINGE ISCAR H=32 sp.4 cod. SGFH_32K_4
 +INSERTI-INSERTS-EINLAGEN cod. 6011366 (10pz.)
 - LAMA-BLADE-KLINGE WALTER H=32 sp.3 cod. G2042.32N-3T45SX-P
 +INSERTI-INSERTS-EINLAGEN cod. SX-3E300N02-CE4 WSM33S (10pz.) + CHIAVE-KEY cod. FS1494
 - LAMA-BLADE-KLINGE WALTER H=32 sp.4 cod. G2042.32N-4T50SX-P
 +INSERTI-INSERTS-EINLAGEN cod. SX-4E400N02-CE4 WSM33S (10pz.) + CHIAVE-KEY cod. FS1494

Cod. MT	N°Utensili N° Tools N° Werkzeuge	Lubr.esterna Ext. coolant Aussenkuehlung	Lubr.interna Coolant through Innenkuehlung	A	B	L MAX
MNZ0520132	1	X	P=70bar	120	114.5	125 (122 ISCAR)
MNZ0520232	1	X	P=70bar	107	100	115 (108 ISCAR)

DMG-MORI
 NZ1500/2000 - NZX1500/2000 - NZX2500 (BMT40) - NT3100/3150/3200 - NL1500/2000/2500 20 STAZ. - NLX1500/2000/2500 20 STAZ. - NT1000/2000
 NTX1000/2000/2500/3000 2ND GEN. 12ST. - DURATURN 2050MC/2550MC - NRX2000 - ALX1500/2000/2500 - ECOTURN 450 (BMT40)

PORTAUTENSILE PER LAMA DOPPIO CON LUBRIFICAZIONE INTERNA
 Radial double blade holder with internal coolant
 Radial Doppel-Abstechhalter mit Innenkuehlung

Subject to change without notice.

M.T. srl
 Via Casino Albini 480
 Tel. 0541/956034-957884
 Fax 0541/956341
 47842 S. GIOVANNI IN M. (RN)
 e-mail: mtma@mtmarchetti.com
 http://www.mtmarchetti.com



PAGINA MNZ520-1-04

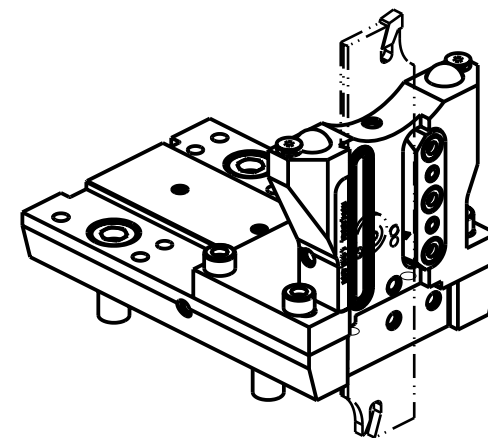
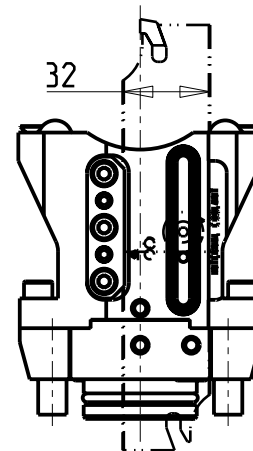
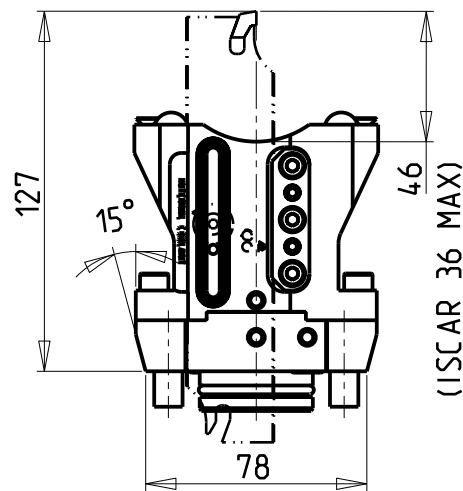
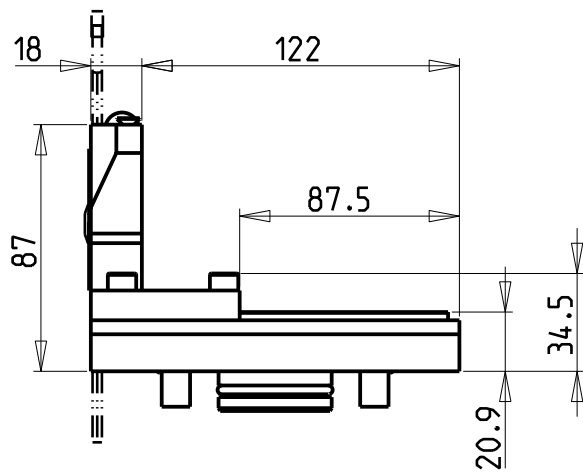

versione dx
right version
version rechts

versione sx
left version
version links

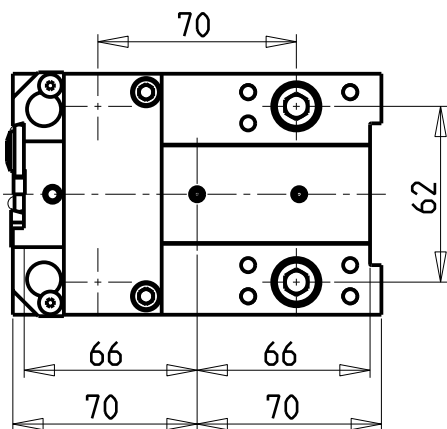

**KIT LAME NON INCLUSI (OPZIONALI)
BLADES NOT SUPPLIED WITH (OPTIONAL)
KLINGEN NICHT INBEGRIFFEN (OPTIONAL)**

- LAMA-BLADE-KLINGE SANDVIK H=32 sp.3 cod. QD_NN2G60C 25A
+INSERTI-INSERTS-EINLAGEN cod. QD_NG_0300_0002_CM_1145 (10 pz.)
- LAMA-BLADE-KLINGE SANDVIK H=32 sp.4 cod. QD_NN2H60C 25A
+INSERTI-INSERTS-EINLAGEN cod. QD_NH_0400_0002_CM_1145 (10 pz.)
- LAMA-BLADE-KLINGE ISCAR H=32 sp.3 cod. SGFH_32K_3
+INSERTI-INSERTS-EINLAGEN cod. 6011365 (10pz.)
- LAMA-BLADE-KLINGE ISCAR H=32 sp.4 cod. SGFH_32K_4
+INSERTI-INSERTS-EINLAGEN cod. 6011366 (10pz.)
- LAMA-BLADE-KLINGE WALTER H=32 sp.3 cod. G2042.32N-3T45SX-P
+INSERTI-INSERTS-EINLAGEN cod. SX-3E300N02-CE4 WSM33S (10pz.) + CHIAVE-KEY cod. FS1494
- LAMA-BLADE-KLINGE WALTER H=32 sp.4 cod. G2042.32N-4T50SX-P
+INSERTI-INSERTS-EINLAGEN cod. SX-4E400N02-CE4 WSM33S (10pz.) + CHIAVE-KEY cod. FS1494

Cod. MT		N°Utensili N°Tools N°Werkzeuge	Reversibile lato mandrino/contromandrino Reversible sub/main spindle side Umkehrbare Spindel-seite/ Gegenspindel-seite	Lubr.esterna Ext. coolant Aussenkuehlung	Lubr.interna Coolant through Innenkuehlung
versione dx right version version rechts	versione sx left version version links				
MNZ0530132R	MNZ0530132L	1	X	X	P=70bar

DMG-MORI

NZ1500/2000 - NZX1500/2000 - NZX2500 (BMT40) - NT3100/3150/3200 - NL1500/2000/2500 20 STAZ. - NLX1500/2000/2500 20 STAZ. - NT1000/2000
NTX1000/2000/2500/3000 2ND GEN. 12ST. - DURATURN 2050MC/2550MC - NRX2000 - ALX1500/2000/2500 - ECOTURN 450 (BMT40)

PORTAUTENSILE RADIALE PER LAMA CON LUBRIFICAZIONE INTERNA

Radial blade holder with internal coolant

Radial Abstechhalter mit Innenkuehlung

Subject to change without notice.

M.T. srl

Via Casino Albini 480
Tel. 0541/956034-957884
Fax 0541/956341
47842 S. GIOVANNI IN M. (RN)
e-mail: mtma@mtmarchetti.com
http://www.mtmarchetti.com



PAGINA MNZ520-1-05

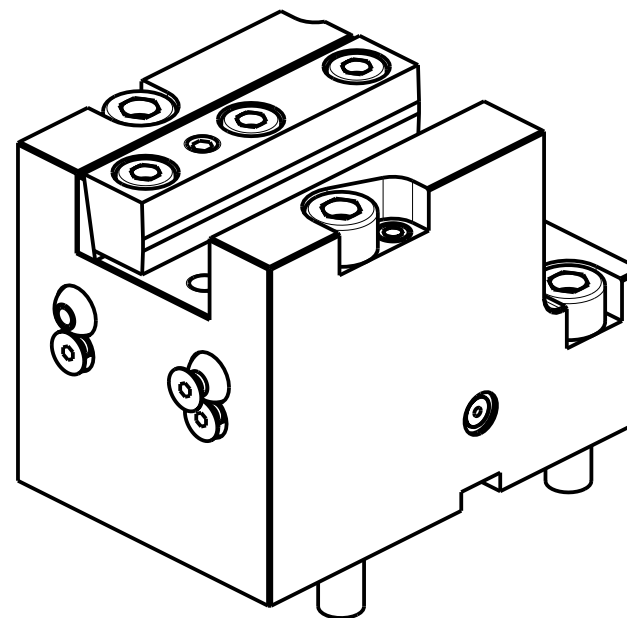
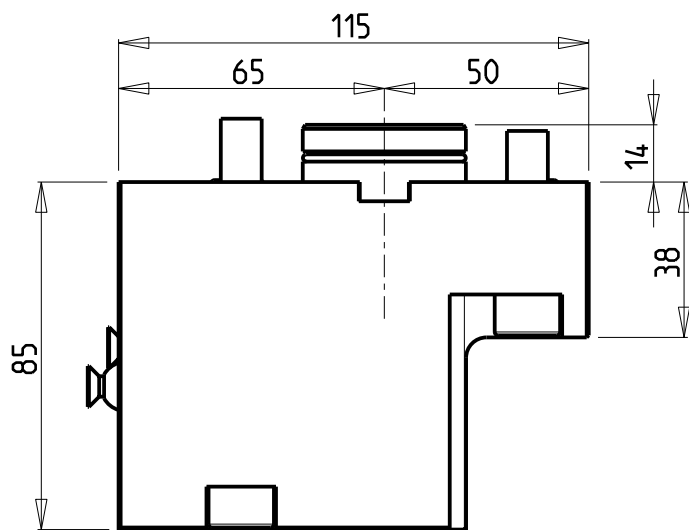
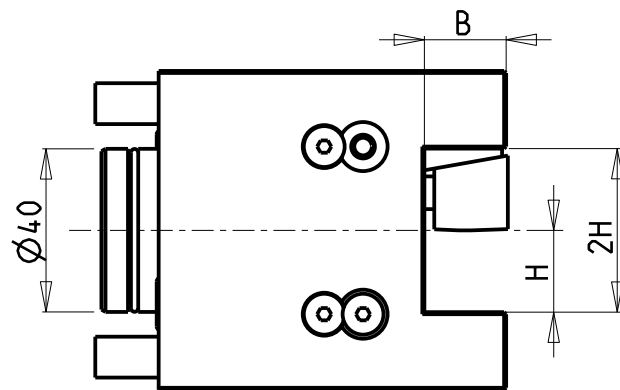
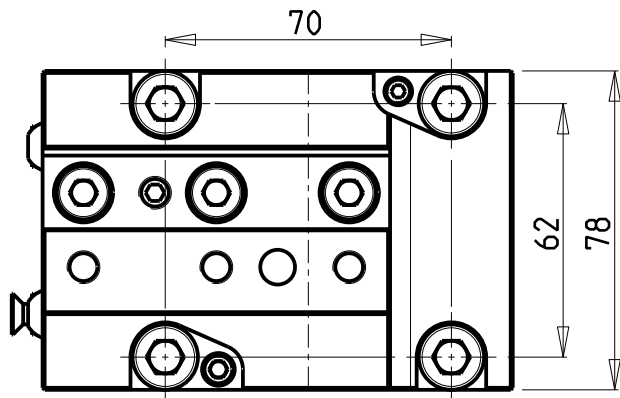

Cod. MT	N°Utensili N°Tools N°Werkzeuge	Reversibile lato mandrino/contromandrino Reversible sub/main spindle side Umkehrbare Spindel-seite/ Gegenspindel-seite	Misure Dimensions Masse	B	H
MNZ0132000	1	X	mm	20	20
MNZ0131905	1	X	Inch	3/4"	3/4"

DMG-MORI

NZ1500/2000 - NZX1500/2000 - NZX2500 (BMT40) - NT3100/3150/3200 - NL1500/2000/2500 20 STAZ. - NLX1500/2000/2500 20 STAZ. - NT1000/2000
NTX1000/2000 - NTX1000/2000/2500/3000 2ND GEN. 12ST. - DURATURN 2050MC/2550MC - NRX2000 - ALX1500/2000/2500 - ECOTURN 450 (BMT40)

PORTAUTENSILE ASSIALE SINGOLO QD=20mm / QD=3/4" H=85mm

Axial single static tool QD=20mm / QD=3/4" H=85mm

Axial Single-Werkzeughalter QD=20mm / QD=3/4" H=85mm

Subject to change without notice.

M.T. srl

Via Casino Albini 480
Tel. 0541/956034-957884
Fax 0541/956341

47842 S. GIOVANNI IN M. (RN)
e-mail: mtma@mtmarchetti.com
http://www.mtmarchetti.com



PAGINA MNZ550-1-00

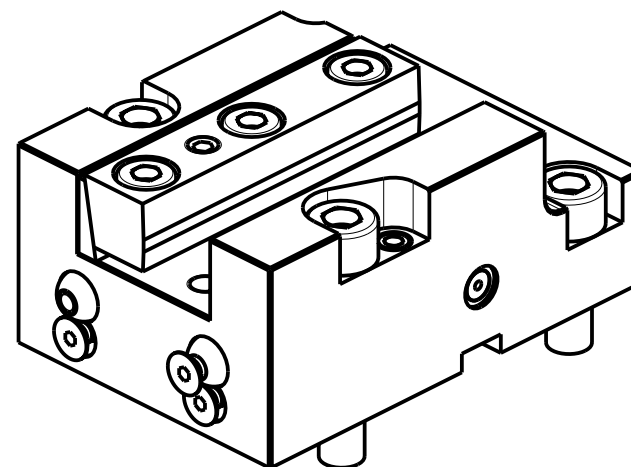
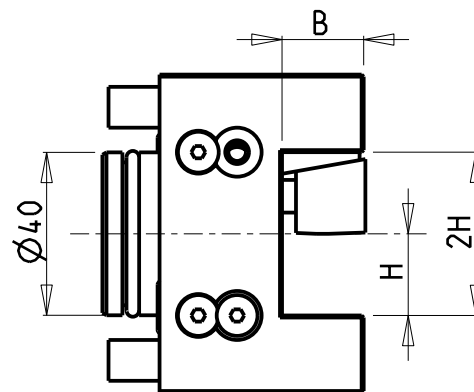
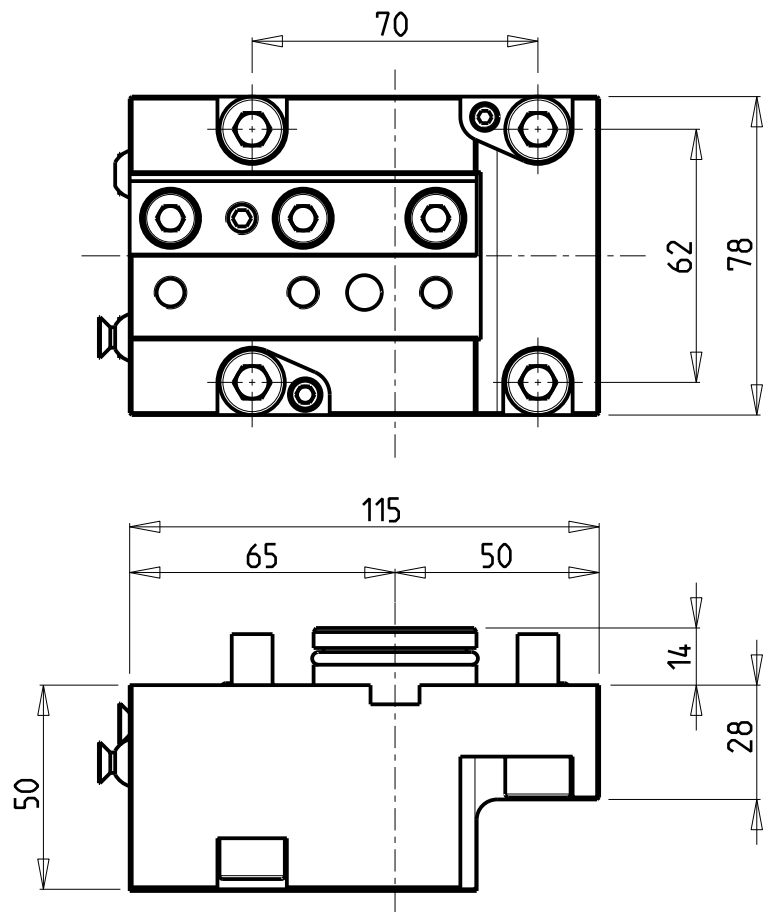

Cod. MT	N°Utensili N°Tools N°Werkzeuge	Reversibile lato mandrino/contromandrino Reversible sub/main spindle side Umkehrbare Spindel-seite/ Gegenspindel-seite	Misure Dimensions Masse	B	H
MNZ0562000	1	X	mm	20	20
MNZ0561905	1	X	Inch	3/4"	3/4"

DMG-MORI

NL1500/2000/2500 20 STAZ. - NLX1500/2000/2500 20 STAZ. - NT1000/2000 - NTX1000/2000
 DURATURN 2050MC/2550MC - ECOTURN 450 (BMT40)

PORTAUTENSILE ASSIALE SINGOLO QD=20mm / QD=3/4" H=50mm

Axial single static tool QD=20mm / QD=3/4" H=50mm

Axial Single-Werkzeughalter QD=20mm / QD=3/4" H=50mm

Subject to change without notice.

M.T. srl

Via Casino Albini 480
 Tel. 0541/956034-957884
 Fax 0541/956341
 47842 S. GIOVANNI IN M. (RN)
 e-mail: mtma@mtmarchetti.com
 http://www.mtmarchetti.com



PAGINA MNZ550-1-10

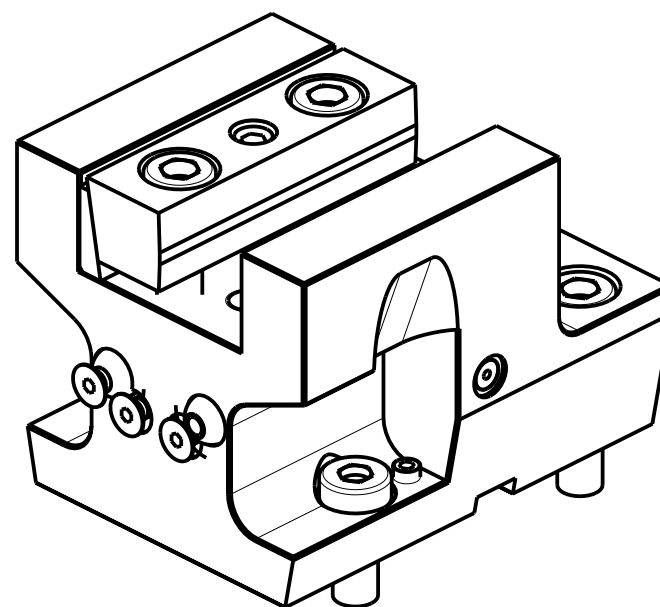
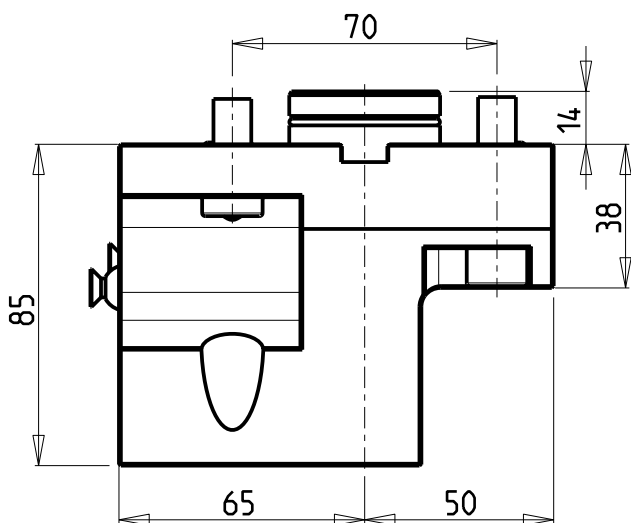
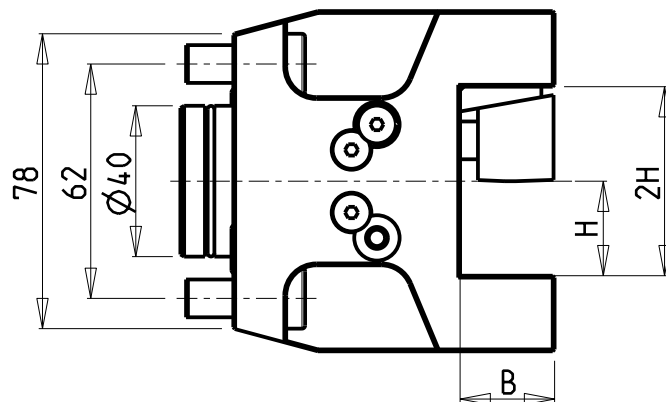
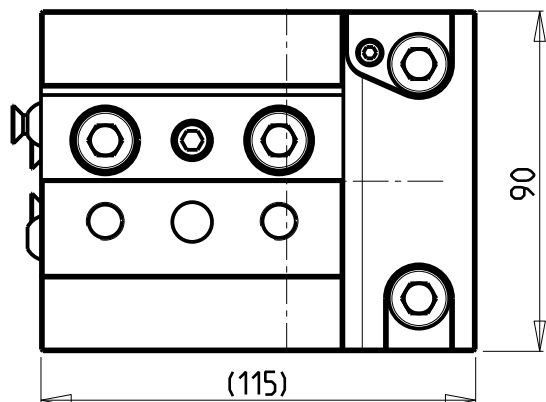

Cod. MT	N°Utensili N° Tools N° Werkzeuge	Reversibile lato mandrino/contromandrino Reversible sub/main spindle side Umkehrbare Spindel-seite/ Gegenspindel-seite	Misure Dimensions Masse	B	H
MNZ0132500	1	X	mm	25	25

DMG-MORI

NZ1500/2000 - NZX1500/2000 - NZX2500 (BMT40) - NT3100/3150/3200 - NL1500/2000/2500 20 STAZ. - NLX1500/2000/2500 20 STAZ. - NT1000/2000
NTX1000/2000 - NTX1000/2000/2500/3000 2ND GEN. 12ST. - DURATURN 2050MC/2550MC - NRX2000 - ALX1500/2000/2500 - ECOTURN 450 (BMT40)

PORTAUTENSILE ASSIALE SINGOLO QD=25mm

Axial single static tool QD=25mm

Axial Single-Werkzeughalter QD=25mm

Subject to change without notice.

M.T. srl

Via Casino Albini 480
Tel. 0541/956034-957884

Fax 0541/956341

47842 S. GIOVANNI IN M. (RN)

e-mail: mtma@mtmarchetti.com

http://www.mtmarchetti.com



PAGINA MNZ552-1-00

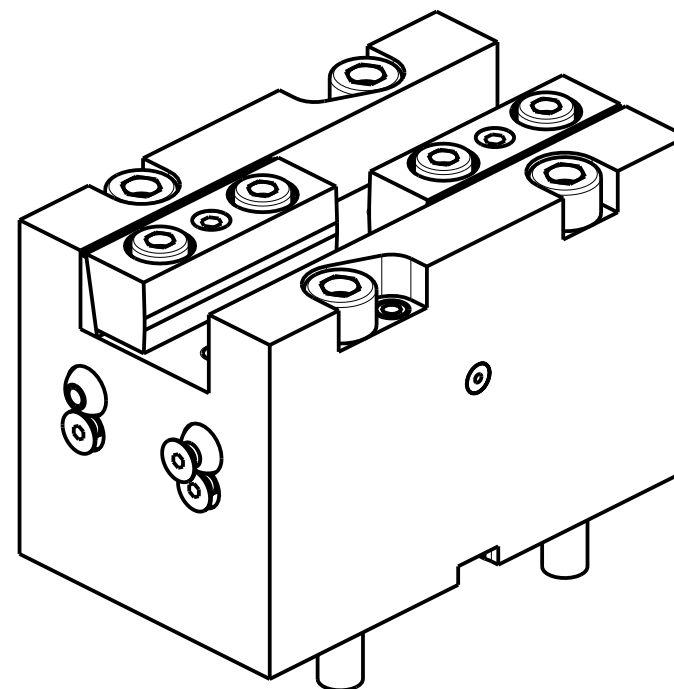
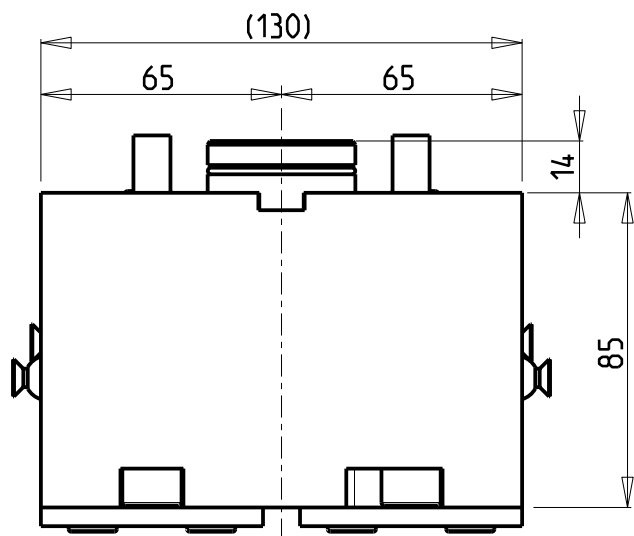
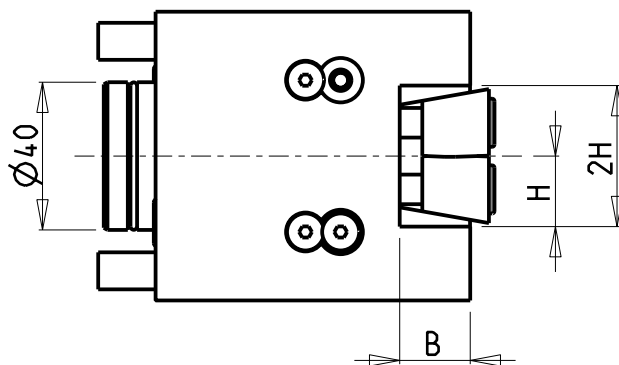
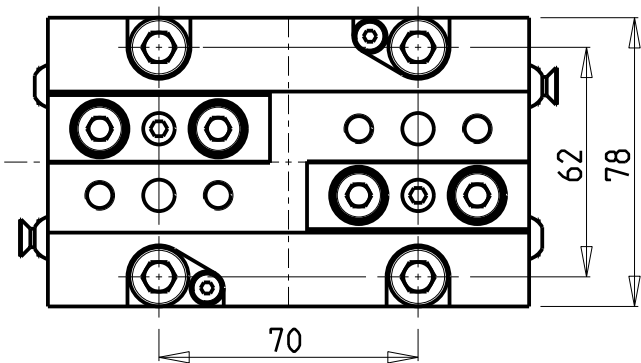

Cod. MT	N°Utensili N° Tools N° Werkzeuge	Reversibile lato mandrino/contromandrino Reversible sub/main spindle side Umkehrbare Spindel-seite/ Gegenspindel-seite	Misure Dimensions Masse	B	H
MNZ0192000	1/2	X	mm	20	20
MNZ0191905	1/2	X	Inch	3/4"	3/4"

DMG-MORI

NZ1500/2000 - NZX1500/2000 - NZX2500 (BMT40) - NT3100/3150/3200 - NL1500/2000/2500 20 STAZ. - NLX1500/2000/2500 20 STAZ.
NT1000/2000 - NTX1000/2000 - DURATURN 2050MC/2550MC - ALX1500/2000/2500 - ECOTURN 450 (BMT40)

PORTAUTENSILE ASSIALE DOPPIO QD=20mm / QD=3/4"

Axial double static tool QD=20mm / QD=3/4"

Axial Doppel-Werkzeughalter QD=20mm / QD=3/4"

Subject to change without notice.

M.T. srl

Via Casino Albini 480
Tel. 0541/956034-957884
Fax 0541/956341

47842 S. GIOVANNI IN M. (RN)
e-mail: mtma@mtmarchetti.com
http://www.mtmarchetti.com



PAGINA MNZ570-1-00

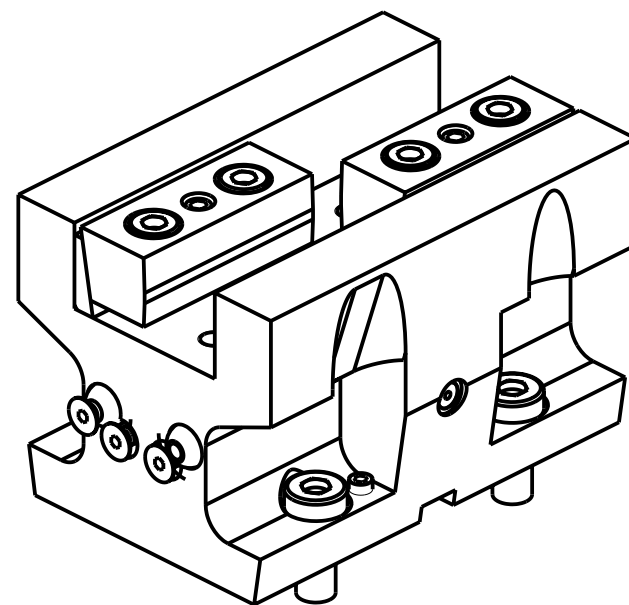
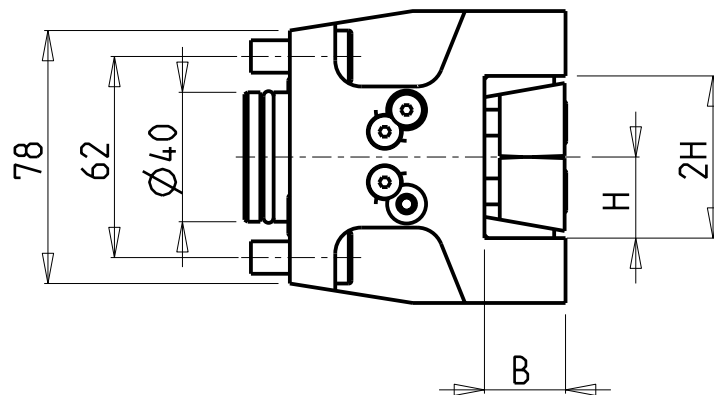
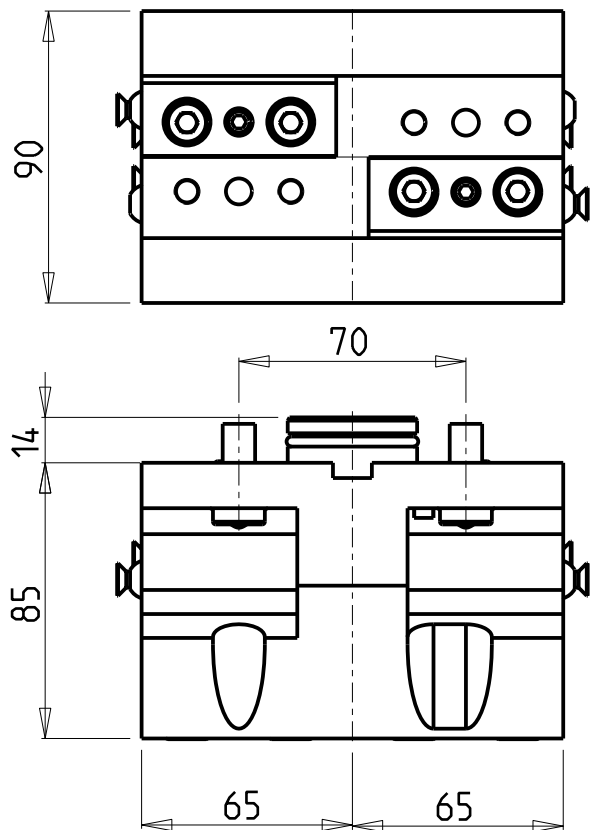

Cod. MT	N°Utensili N° Tools N° Werkzeuge	Reversibile lato mandrino/contromandrino Reversible sub/main spindle side Umkehrbare Spindel-seite/ Gegenspindel-seite	Misure Dimensions Masse	B	H
MNZ0192500	1/2	X	mm	25	25
MNZ0192540	1/2	X	Inch	1"	1"

DMG-MORI

NZ1500/2000 - NZX1500/2000 - NZX2500 (BMT40) - NT3100/3150/3200 - NL1500/2000/2500 20 STAZ. - NLX1500/2000/2500 20 STAZ.
 NT1000/2000 - NTX1000/2000 - DURATURN 2050MC/2550MC - ALX1500/2000/2500 - ECOTURN 450 (BMT40)

PORTAUTENSILE ASSIALE DOPPIO QD=25mm / QD=1"

Axial double static tool QD=25mm / QD=1"

Axial Doppel-Werkzeughalter QD=25mm / QD=1"

Subject to change without notice.

M.T. srl

Via Casino Albini 480
 Tel. 0541/956034-957884
 Fax 0541/956341
 47842 S. GIOVANNI IN M. (RN)
 e-mail: mtma@mtmarchetti.com
 http://www.mtmarchetti.com



PAGINA MNZ572-1-00

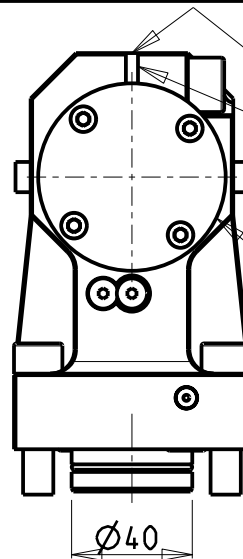
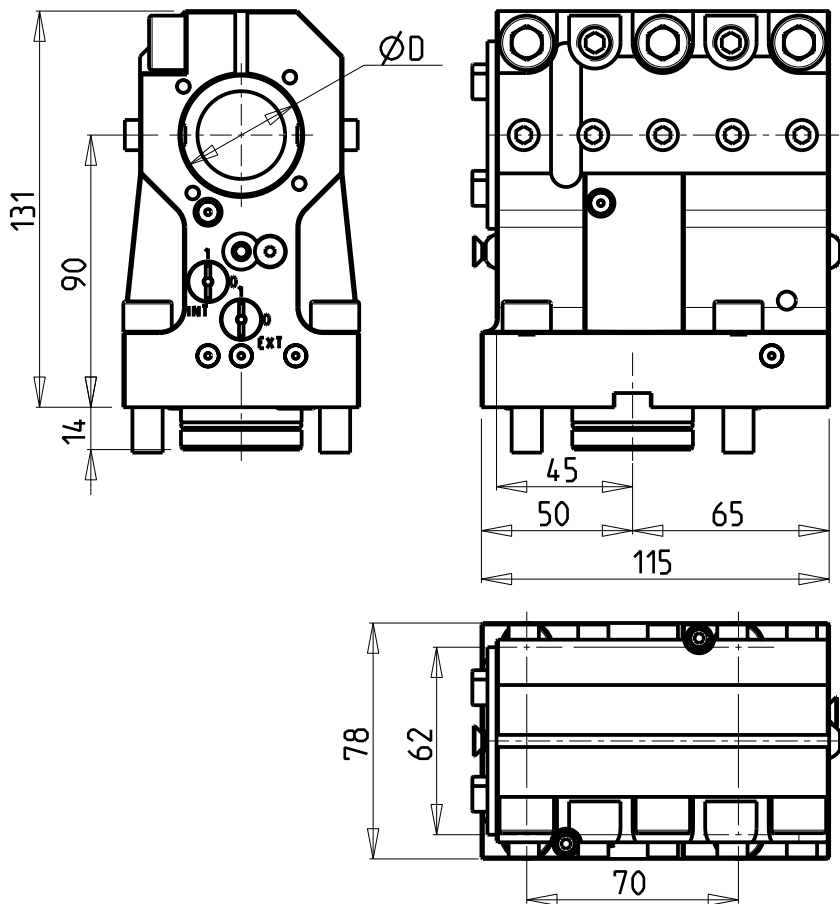

SOLO GUARNIZIONE (OPZIONALE)
 ONLY SEAL (OPTIONAL)
 NUR DICHTUNG (OPTIONAL)
 cod. 0520013

KIT ADDUZIONE INTERNA (OPZIONALE)
 KIT FOR INTERNAL COOLANT (OPTIONAL)
 KIT FUER INTERNE KUEHLMITTELZUFUHR (OPTIONAL)
 Ø40 cod. KIT1003003
 Ø1 1/2" cod. KIT1003004

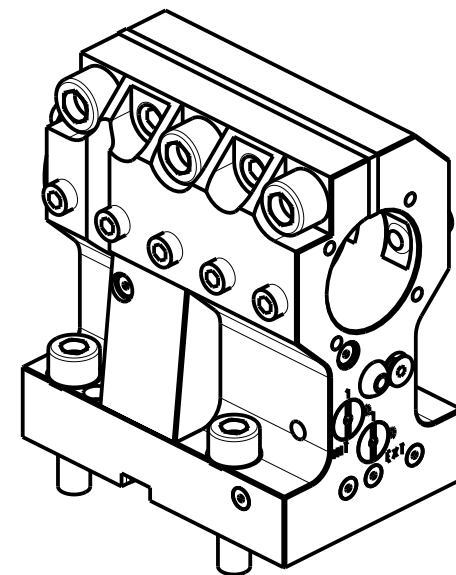

PER BOCCOLE DI RIDUZIONE VEDI PAG. TBL150-1-00
 FOR REDUCING BUSHINGS SEE PAGE TBL150-1-00
 FUER REDUZIERBUCHSE SIEHE SEITE TBL150-1-00

Cod. MT	N°Utensili N°Tools N°Werkzeuge	Lubrificazione int. opzionale Coolant through optional Innenkuehlung Optional	Lubrificazione est. Ext. coolant Aussenkuehlung	Reversibile lato mandrino/contromandrino Reversible sub/main spindle side Umkehrbare Spindel-seite/ Gegenspindel-seite	Misure Dimensions Masse	D
MNZ0154000	1	X	X	X	mm	40
MNZ0153810	1	X	X	X	Inch	1-1/2"

DMG-MORI

NZ1500/2000 - NZX1500/2000 - NZX2500 (BMT40) - NT3100/3150/3200 - NL1500/2000/2500 20 STAZ. - NLX1500/2000/2500 20 STAZ.
 NTX1000/2000/2500/3000 2ND GEN. 12ST. - DURATURN 2050MC/2550MC - ALX1500/2000/2500 - ECOTURN 450 (BMT40)

PORTAUTENSILE ASSIALE PER BARENO Ø40mm / Ø1 1/2" H=90mm

Axial single boring bar holder Ø40mm / Ø1 1/2" H=90mm

Axial Bohrhälter Ø40mm / Ø1 1/2" H=90mm

Subject to change without notice.

M.T. srl

Via Casino Albini 480

Tel. 0541/956034-957884

Fax 0541/956341

47842 S. GIOVANNI IN M. (RN)

e-mail: mtma@mtmarchetti.com

http://www.mtmarchetti.com



PAGINA MNZ630-1-20

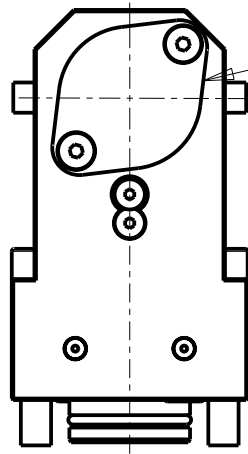
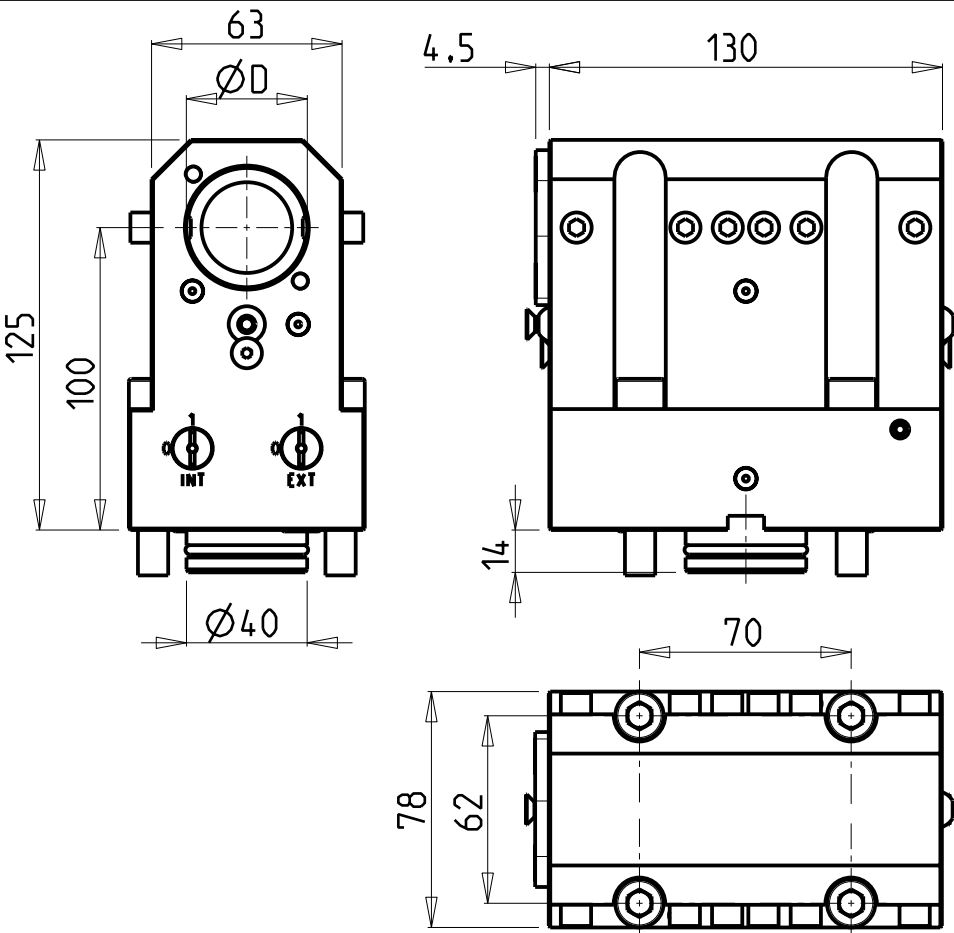

KIT ADDUZIONE INTERNA (OPZIONALE)
 KIT FOR INTERNAL COOLANT (OPTIONAL)
 KIT FUER INTERNE KUEHLMITTELZUFUHR (OPTIONAL)
 Ø40 cod. KIT1000018
 Ø1 1/2" cod. KIT1000021

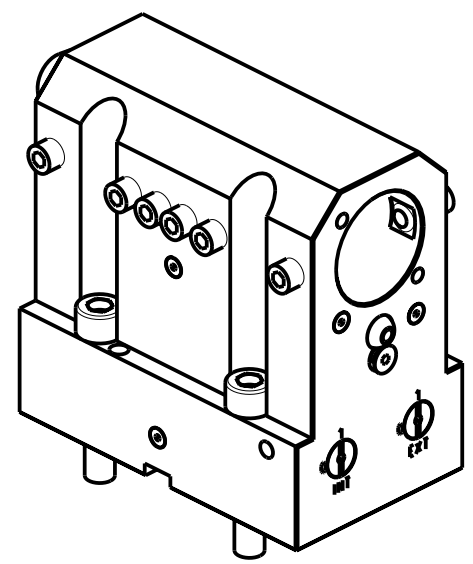

Cod. MT	N°Utensili N°Tools N°Werkzeuge	Reversibile lato mandrino/contromandrino Reversible sub/main spindle side Umkehrbare Spindel-seite/ Gegenspindel-seite	Lubrificazione int. opzionale Coolant through optional Innenkuehlung Optional	Lubrificazione est. Ext. coolant Aussenkuehlung	Misure Dimensions Masse	D
MNZ0144000	1+1	X	X	X	mm	40
MNZ0143810	1+1	X	X	X	inch	1 1/2"

PER BOCCOLE DI RIDUZIONE VEDI PAG. TBL150-1-00
 FOR REDUCING BUSHINGS SEE PAGE TBL150-1-00
 FUER REDUZIERBUCHSE SIEHE SEITE TBL150-1-00

DMG-MORI
 NZ1500/2000 - NZX1500/2000 - NZX2500 (BMT40) - NT3100/3150/3200 - NL1500/2000/2500 20 STAZ. - NLX1500/2000/2500 20 STAZ. - NT1000/2000
 NTX1000/2000 - NTX1000/2000/2500/3000 2ND GEN. 12ST. - DURATURN 2050MC/2550MC - NRX2000 - ALX1500/2000/2500 - ECOTURN 450 (BMT40)

PORTAUTENSILE ASSIALE PER BARENO Ø40mm H=100mm
 Axial single boring bar holder Ø40mm H=100mm
 Axial Bohrhalter Ø40mm H=100mm

Subject to change without notice.

M.T. srl
 Via Casino Albini 480
 Tel. 0541/956034-957884
 Fax 0541/956341
 47842 S. GIOVANNI IN M. (RN)
 e-mail: mtma@mtmarchetti.com
 http://www.mtmarchetti.com



PAGINA MNZ640-1-10

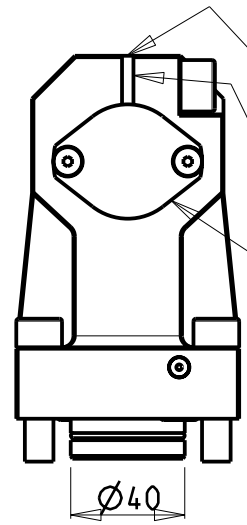
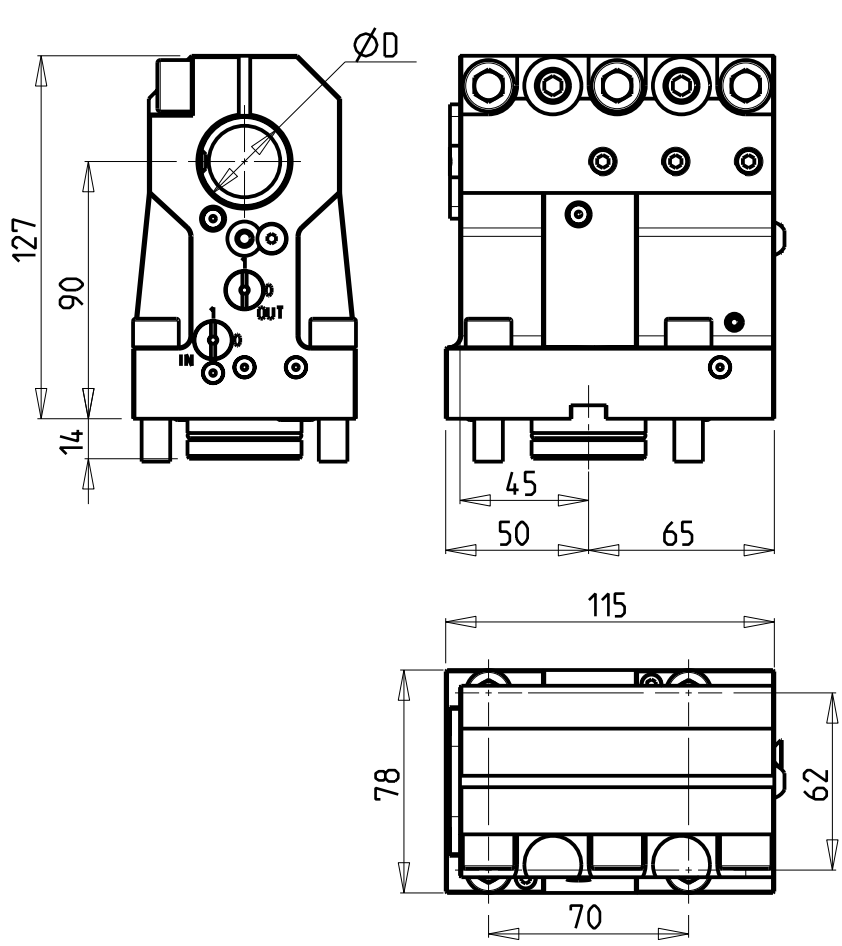

SOLO GUARNIZIONE (OPZIONALE)
 ONLY SEAL (OPTIONAL)
 NUR DICHTUNG (OPTIONAL)
 cod. 0520013

KIT ADDUZIONE INTERNA (OPZIONALE)
 KIT FOR INTERNAL COOLANT (OPTIONAL)
 KIT FUER INTERNE KUEHLMITTELZUFUHR (OPTIONAL)
 Ø32 - Ø1 1/4" cod. KIT1003001

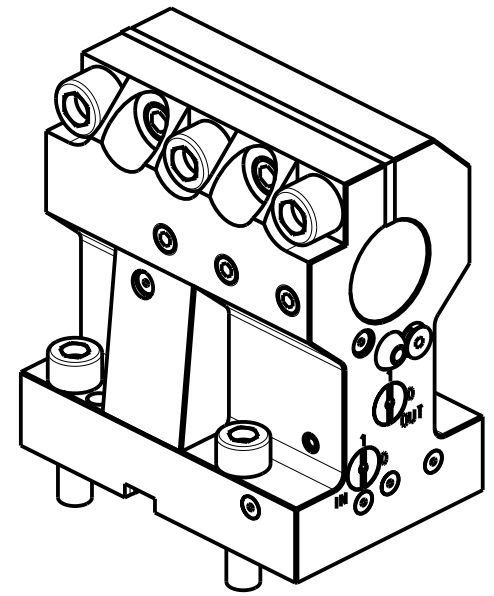

PER BOCCOLE DI RIDUZIONE VEDI PAG. TBL150-1-00
 FOR REDUCING BUSHINGS SEE PAGE TBL150-1-00
 FUER REDUZIERBUCHSE SIEHE SEITE TBL150-1-00

Cod. MT	N°Utensili N°Tools N°Werkzeuge	Lubrificazione int. opzionale Coolant through optional Innenkuehlung Optional	Lubrificazione est. Ext. coolant Aussenkuehlung	Reversibile lato mandrino/contromandrino Reversible sub/main spindle side Umkehrbare Spindel-seite/ Gegenspindel-seite	Misure Dimensions Masse	D
MNZ0153200	1	X	X	X	mm	32
MNZ0153175	1	X	X	X	Inch	1 1/4"

DMG-MORI
 NZ1500/2000 - NZX1500/2000 - NZX2500 (BMT40) - NT3100/3150/3200 - NL1500/2000/2500 20 STAZ. - NLX1500/2000/2500 20 STAZ.
 NTX1000/2000/2500/3000 2ND GEN. 12ST. - DURATURN 2050MC/2550MC - ALX1500/2000/2500 - ECOTURN 450 (BMT40)

PORTAUTENSILE ASSIALE PER BARENO Ø32mm / Ø1 1/4" H=90mm
 Axial single boring bar holder Ø32mm / Ø1 1/4" H=90mm
 Axial Bohrhalter Ø32mm / Ø1 1/4" H=90mm

Subject to change without notice.

M.T. srl
 Via Casino Albini 480
 Tel. 0541/956034-957884
 Fax 0541/956341
 47842 S. GIOVANNI IN M. (RN)
 e-mail: mtma@mtmarchetti.com
 http://www.mtmarchetti.com



PAGINA MNZ650-1-20

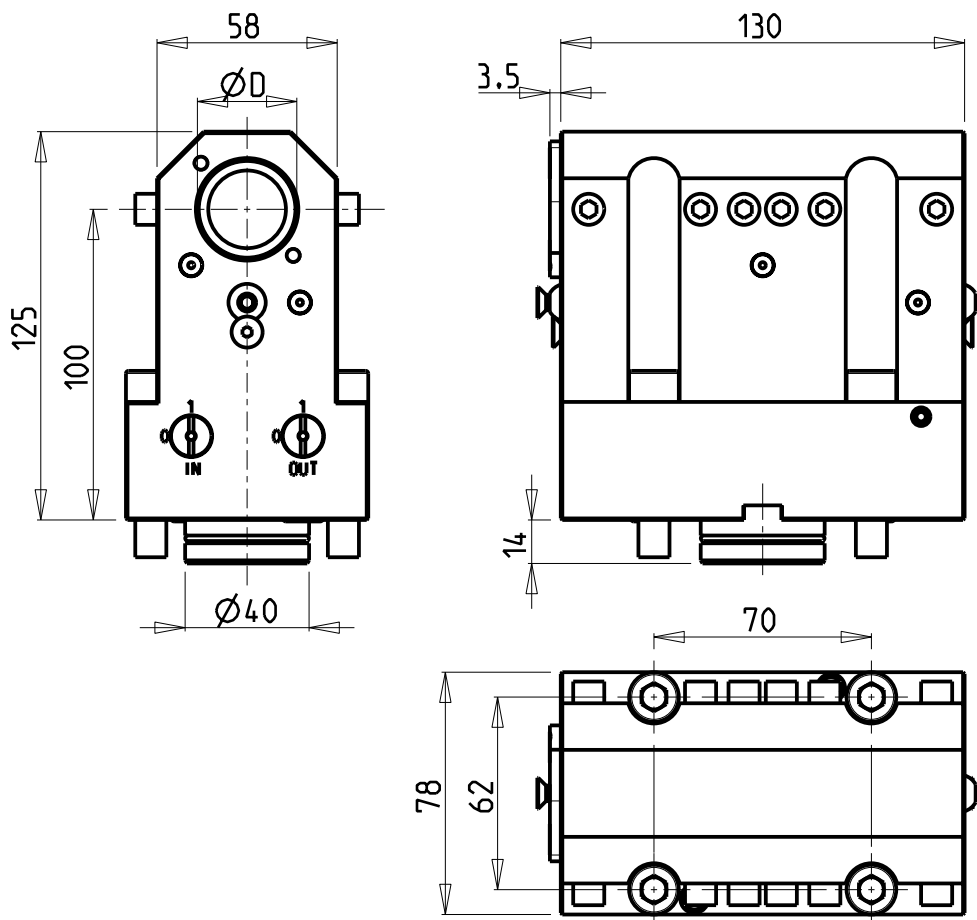

KIT ADDUZIONE INTERNA (OPZIONALE)
 KIT FOR INTERNAL COOLANT (OPTIONAL)
 KIT FUER INTERNE KUEHLMITTELZUFUHR (OPTIONAL)
 Ø32 - Ø1 1/4" cod. KIT1000001

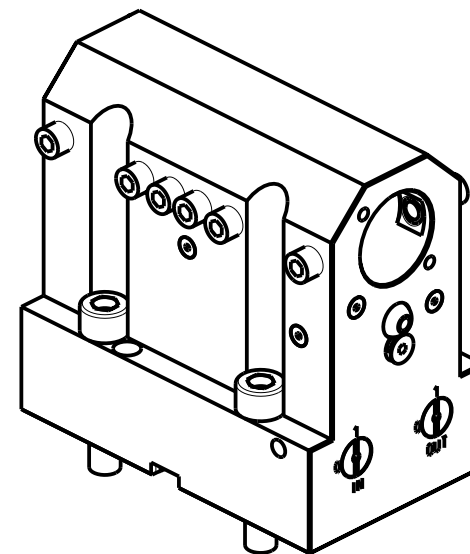
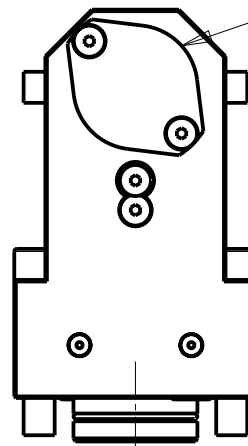

PER BOCCOLE DI RIDUZIONE VEDI PAG. TBL150-1-00
 FOR REDUCING BUSHINGS SEE PAGE TBL150-1-00
 FUER REDUZIERBUCHSE SIEHE SEITE TBL150-1-00

Cod. MT	N°Utensili N°Tools N°Werkzeuge	Reversibile lato mandrino/contromandrino Reversible sub/main spindle side Umkehrbare Spindel-seite/ Gegenspindel-seite	Lubrificazione int. opzionale Coolant through optional Innenkuehlung Optional	Lubrificazione est. Ext. coolant Aussenkuehlung	Misure Dimensions Masse	D
MNZ0143200	1+1	X	X	X	mm	32
MNZ0143175	1+1	X	X	X	Inch	1 1/4"

DMG-MORI

NZ1500/2000 - NZX1500/2000 - NZX2500 (BMT40) - NT3100/3150/3200 - NL1500/2000/2500 20 STAZ. - NLX1500/2000/2500 20 STAZ. - NT1000/2000
 NTX1000/2000 - NTX1000/2000/2500/3000 2ND GEN. 12ST. - DURATURN 2050MC/2550MC - NRX2000 - ALX1500/2000/2500 - ECOTURN 450 (BMT40)

PORTAUTENSILE ASSIALE PER BARENO Ø32mm / Ø1 1/4" H=100mm

Axial single boring bar holder Ø32mm / Ø1 1/4" H=100mm

Axial Bohrhalter Ø32mm / Ø1 1/4" H=100mm

Subject to change without notice.

M.T. srl

Via Casino Albini 480
 Tel. 0541/956034-957884

Fax 0541/956341

47842 S. GIOVANNI IN M. (RN)

e-mail: mtma@mtmarchetti.com

http://www.mtmarchetti.com



PAGINA MNZ660-1-10

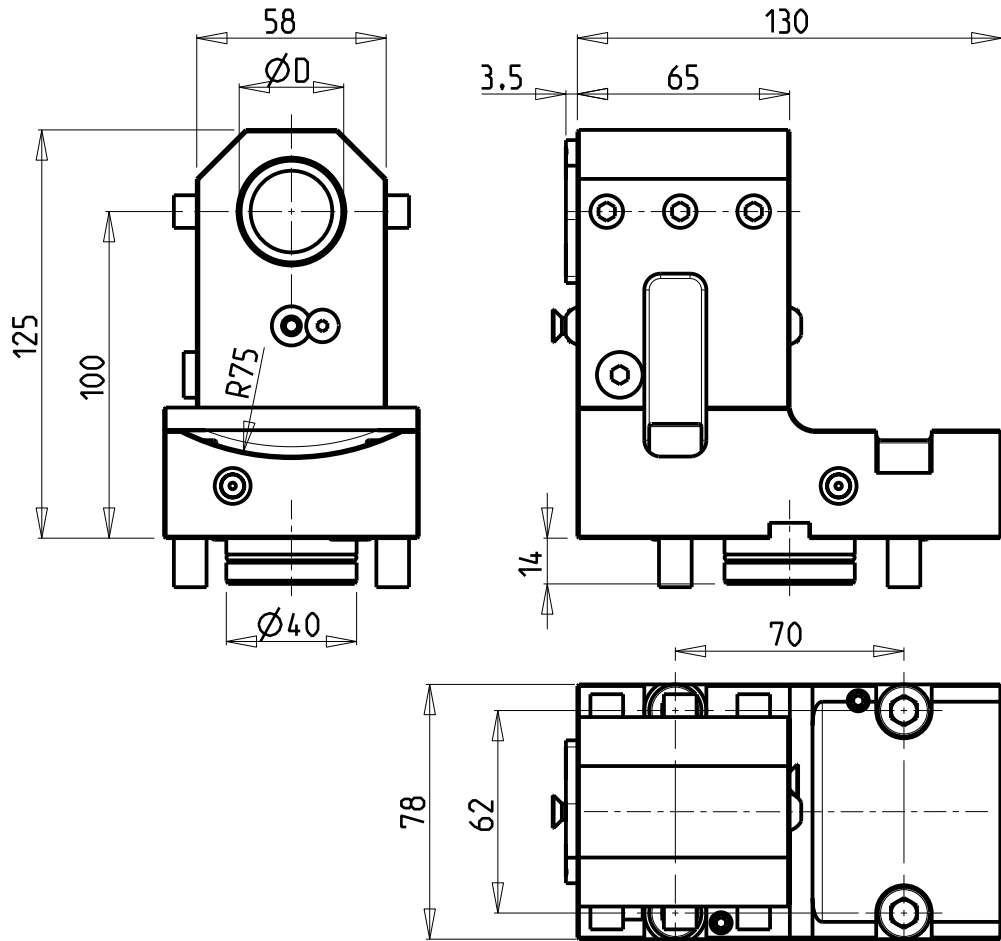

KIT ADDUZIONE INTERNA (OPZIONALE)
 KIT FOR INTERNAL COOLANT (OPTIONAL)
 KIT FUER INTERNE KUEHLMITTELZUFUHR (OPTIONAL)
 Ø32 / Ø1 1/4" cod. KIT1000001

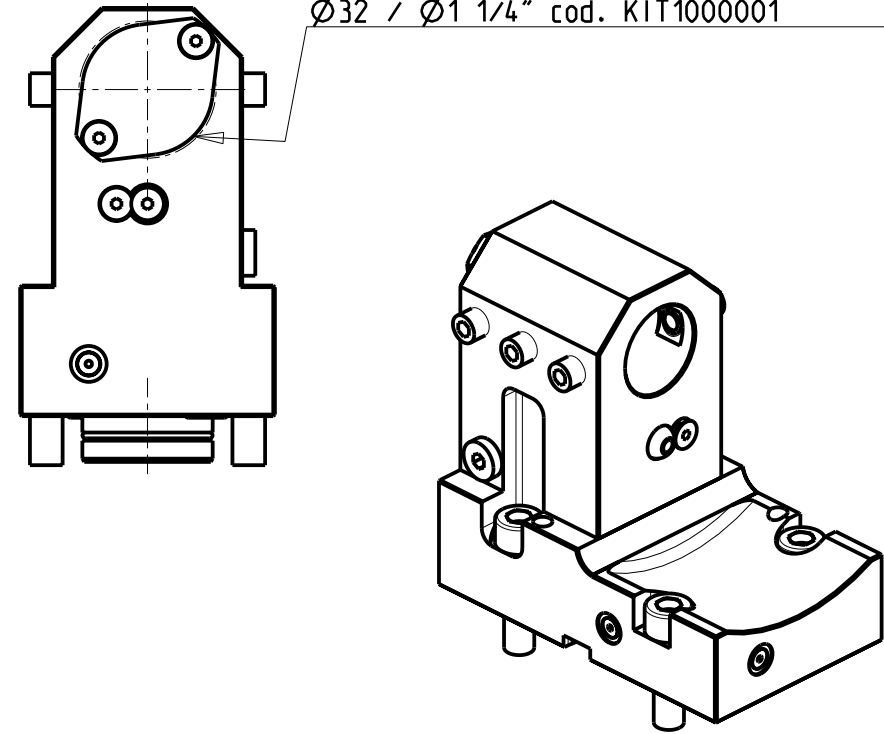

PER BOCCOLE DI RIDUZIONE VEDI PAG. TBL150-1-00
 FOR REDUCING BUSHINGS SEE PAGE TBL150-1-00
 FUER REDUZIERBUCHSE SIEHE SEITE TBL150-1-00

Cod. MT	Reversibile lato mandrino/contromandrino Reversible sub/main spindle side Umkehrbare Spindelsetze/ Gegenspindelsetze	Lubrificazione int. opzionale Coolant through optional Innenkuehlung Optional	Lubrificazione est. Ext. coolant Aussenkuehlung	Misure Dimensions Masse	D
MNZ0223200	X	X	X	mm	32
MNZ0223175	X	X	X	inch	1 1/4"

DMG-MORI

NZ1500/2000 - NZX1500/2000 - NZX2500 (BMT40) - NT3100/3150/3200 - NL1500/2000/2500 20 STAZ. - NLX1500/2000/2500 20 STAZ. - NT1000/2000
 NTX1000/2000 - NTX1000/2000/2500/3000 2ND GEN. 12ST. - DURATURN 2050MC/2550MC - NRX2000 - ALX1500/2000/2500 - ECOTURN 450 (BMT40)

PORTAUTENSILE ASSIALE ARRETRATO PER BARENO Ø32mm H=100mm

Axial single rear set boring bar holder Ø32mm H=100mm

Axial Bohrhalter zurueckversetzt Ø32mm H=100mm

Subject to change without notice.

M.T. srl

Via Casino Albini 480
 Tel. 0541/956034-957884
 Fax 0541/956341

47842 S. GIOVANNI IN M. (RN)
 e-mail: mtma@mtmarchetti.com
 http://www.mtmarchetti.com



PAGINA MNZ845-1-10

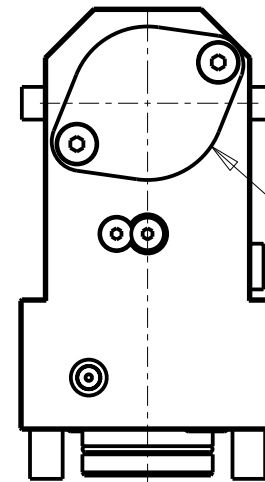
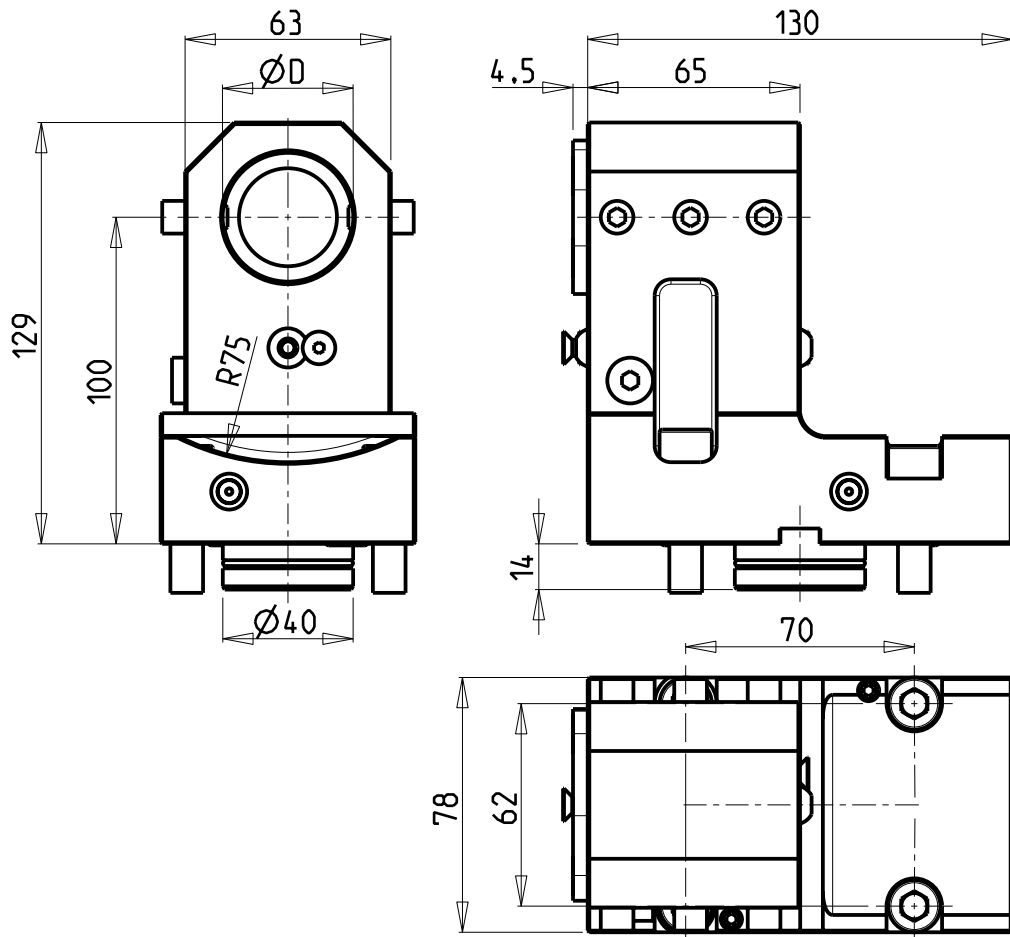

KIT ADDUZIONE INTERNA (OPZIONALE)
 KIT FOR INTERNAL COOLANT (OPTIONAL)
 KIT FUER INTERNE KUEHLMITTELZUFUHR (OPTIONAL)
 Ø40 cod. KIT1000018
 Ø1 1/2" cod. KIT1000021

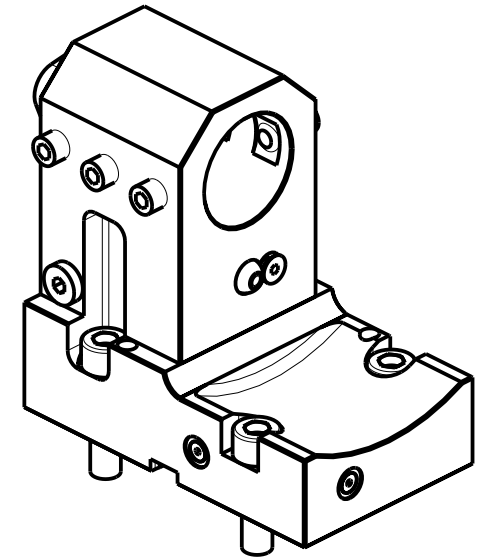

PER BOCCOLE DI RIDUZIONE VEDI PAG. TBL150-1-00
 FOR REDUCING BUSHINGS SEE PAGE TBL150-1-00
 FUER REDUZIERBUCHSE SIEHE SEITE TBL150-1-00

Cod. MT	Reversibile lato mandrino/contromandrino Reversible sub/main spindle side Umkehrbare Spindel-seite/ Gegenspindel-seite	Lubrificazione int. opzionale Coolant through optional Innenkuehlung Optional	Lubrificazione est. Ext. coolant Aussenkuehlung	Misure Dimensions Masse	D
MNZ0224000	X	X	X	mm	40
MNZ0223810	X	X	X	inch	1 1/2"

DMG-MORI

NZ1500/2000 - NZX1500/2000 - NZX2500 (BMT40) - NT3100/3150/3200 - NL1500/2000/2500 20 STAZ. - NLX1500/2000/2500 20 STAZ.
 NTX1000/2000/2500/3000 2ND GEN. 12ST. - DURATURN 2050MC/2550MC - ALX1500/2000/2500 - ECOTURN 450 (BMT40)

PORTAUTENSILE ASSIALE ARRETRATO PER BARENO Ø40mm H=100mm

Axial single rear set boring bar holder Ø40mm H=100mm

Axial Bohrhälter zurueckversetzt Ø40mm H=100mm

Subject to change without notice.

M.T. srl

Via Casino Albini 480
 Tel. 0541/956034-957884
 Fax 0541/956341
 47842 S. GIOVANNI IN M. (RN)
 e-mail: mtma@mtmarchetti.com
 http://www.mtmarchetti.com



PAGINA MNZ845-1-20

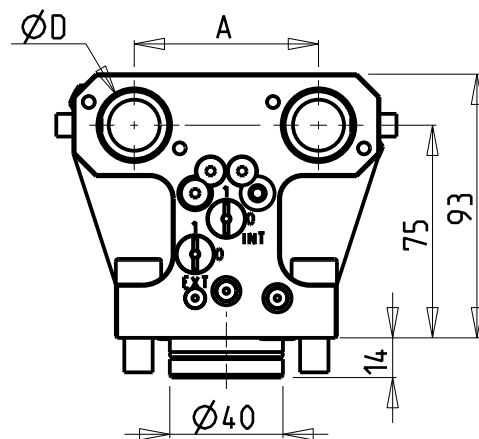
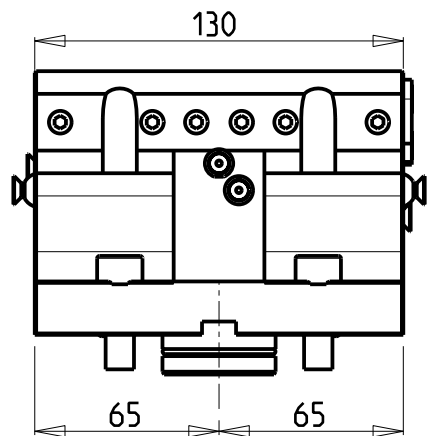
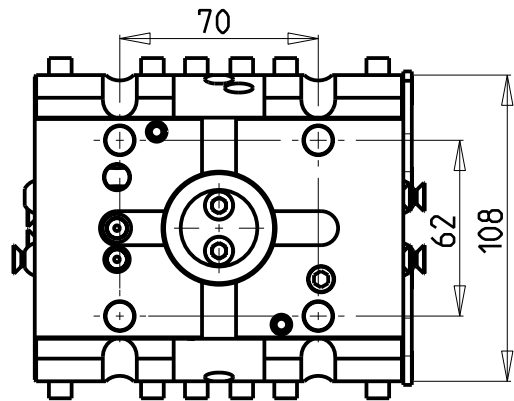

KIT ADDUZIONE INTERNA (OPZIONALE)
 KIT FOR INTERNAL COOLANT (OPTIONAL)
 KIT FUER INTERNE KUEHLMITTELZUFUHR (OPTIONAL)
 Ø25 / Ø1" cod. KIT1000006
 Ø20 cod. KIT1000015
 Ø3/4" cod. KIT1000005

PER BOCCOLE DI RIDUZIONE VEDI PAG. TBL150-1-00
 FOR REDUCING BUSHINGS SEE PAGE TBL150-1-00
 FUR REDUZIERBUCHSE SIEHE SEITE TBL150-1-00

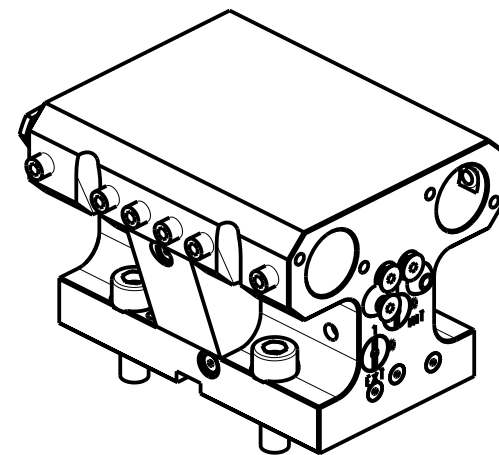
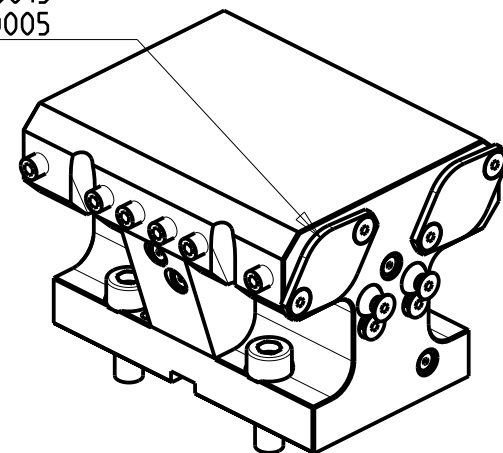

Cod. MT	N°Utensili N°Tools N°Werkzeuge	Reversibile lato mandrino/contromandrino Reversible sub/main spindle side Umkehrbare Spindel-seite/ Gegenspindel-seite	Lubrificazione int. opzionale Coolant through optional Innenkuehlung Optional	Lubrificazione est. Ext. coolant Aussenkuehlung	Misure Dimensions Masse	D	A
MNZ0242500	2+2	X	X	X	mm	25	65
MNZ0242540	2+2	X	X	X	Inch	1"	63.5
MNZ0242000	2+2	X	X	X	mm	20	65
MNZ0241905	2+2	X	X	X	Inch	3/4"	63.5

DMG-MORI

NZ1500/2000 - NZX1500/2000 - NT3100/3150/3200 - NL1500/2000/2500 20 STAZ. - NLX1500/2000/2500 20 STAZ. - NT1000/2000
 NTX1000/2000 - NTX1000/2000/2500/3000 2ND GEN. 12ST. - DURATURN 2050MC/2550MC - ALX1500/2000/2500 - ECOTURN 450 (BMT40)

PORTAUTENSILE ASSIALE PER BARENO 2+2 POSIZIONI Ø25mm / Ø1" / Ø20mm / Ø3/4"

Axial 2+2 position boring bar holder Ø25mm / Ø1" / Ø20mm / Ø3/4"

Axial Bohrhälter 2+2 Positionen Ø25mm / Ø1" / Ø20mm / Ø3/4"

Subject to change without notice.

M.T. srl

Via Casino Albini 480
 Tel. 0541/956034-957884
 Fax 0541/956341

47842 S. GIOVANNI IN M. (RN)
 e-mail: mtma@mtmarchetti.com
 http://www.mtmarchetti.com



PAGINA MNZ864-1-00

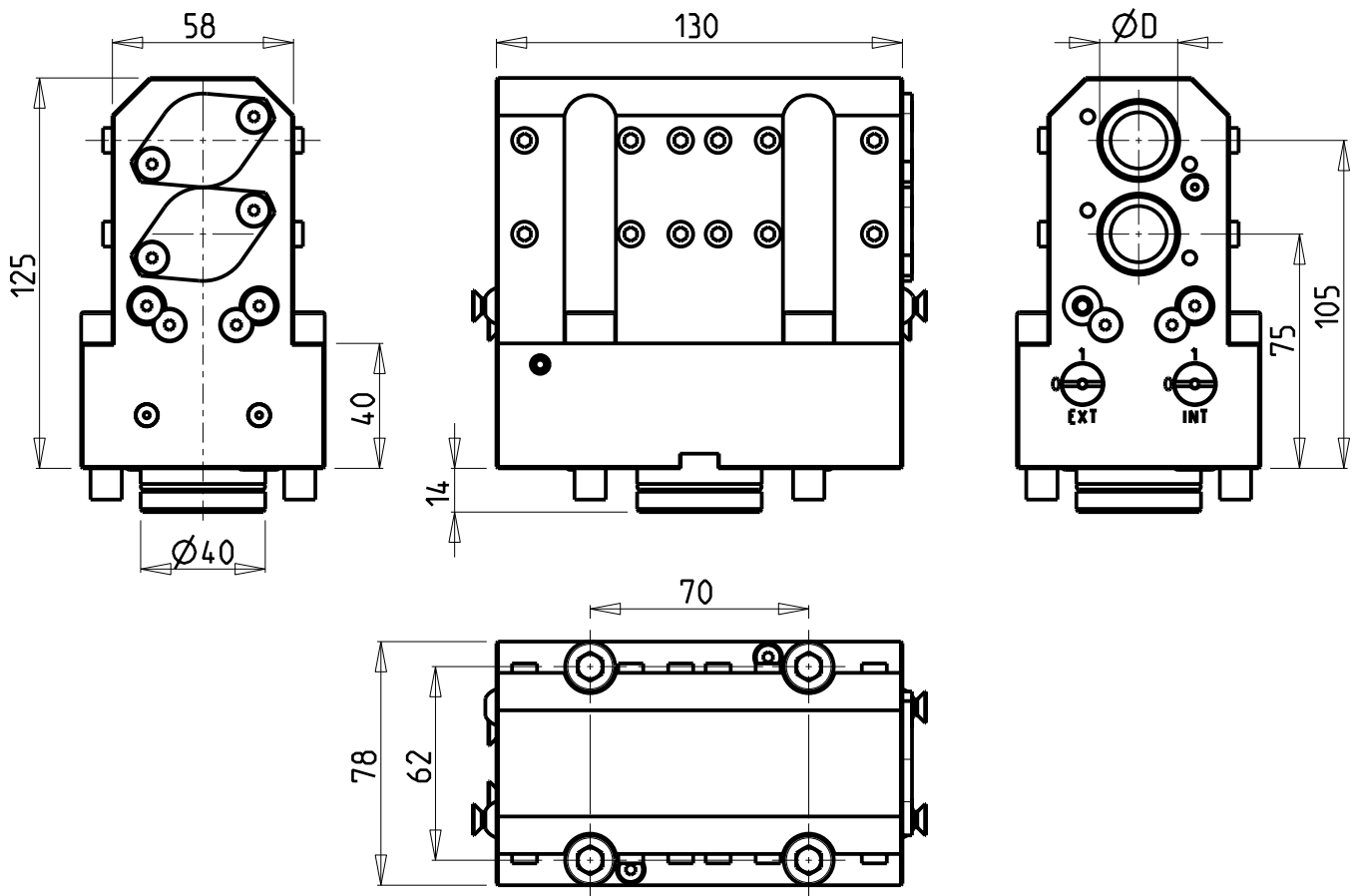

KIT ADDUZIONE INTERNA (OPZIONALE)
 KIT FOR INTERNAL COOLANT (OPTIONAL)
 KIT FUER INTERNE KUEHLMITTELZUFUHR (OPTIONAL)
 Ø25 / Ø1" cod. KIT1000006

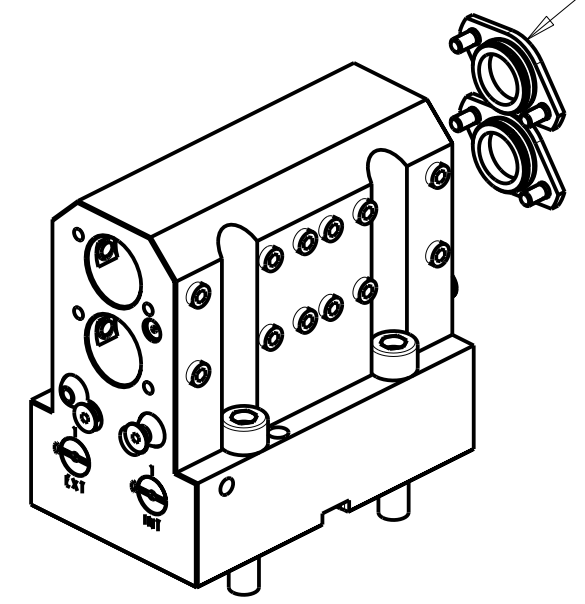

PER BOCCOLE DI RIDUZIONE VEDI PAG. TBL150-1-00
 FOR REDUCING BUSHINGS SEE PAGE TBL150-1-00
 FUER REDUZIERBUCHSE SIEHE SEITE TBL150-1-00

Cod. MT	N°Utensili N°Tools N°Werkzeuge	Reversibile lato mandrino/contromandrino Reversible sub/main spindle side Umkehrbare Spindel-seite/ Gegenspindel-seite	Lubrificazione int. opzionale Coolant through optional Innenkuehlung Optional	Lubrificazione est. Ext. coolant Aussehenkuehlung	Misure Dimensions Masse	D
MNZ0162500	2+2	X	X	X	mm	25
MNZ0162540	2+2	X	X	X	Inch	1"

DMG-MORI
 NZ1500/2000 - NZX1500/2000 - NT3100/3150/3200 - NL1500/2000/2500 20 STAZ. - NLX1500/2000/2500 20 STAZ. - NT1000/2000
 NTX1000/2000 - NTX1000/2000/2500/3000 2ND GEN. 12ST. - DURATURN 2050MC/2550MC - ALX1500/2000/2500 - ECOTURN 450 (BMT40)

PORTAUTENSILE ASSIALE PER BARENO 2+2 POSIZIONI Ø25mm / Ø1"
 Axial 2+2 position boring bar holder Ø25mm / Ø1"
 Axial Bohrhalter 2+2 Positionen Ø25mm / Ø1"

Subject to change without notice.

M.T. srl
 Via Casino Albini 480
 Tel. 0541/956034-957884
 Fax 0541/956341
 47842 S. GIOVANNI IN M. (RN)
 e-mail: mtma@mtmarchetti.com
 http://www.mtmarchetti.com



PAGINA MNZ874-1-00

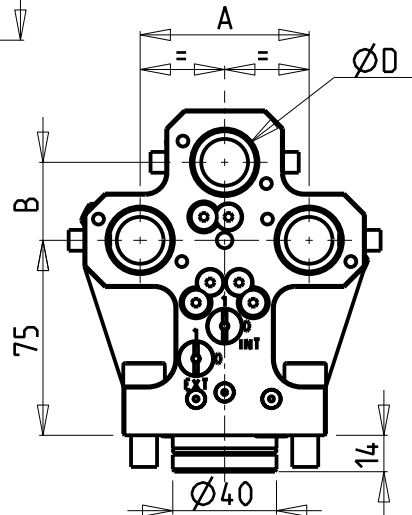
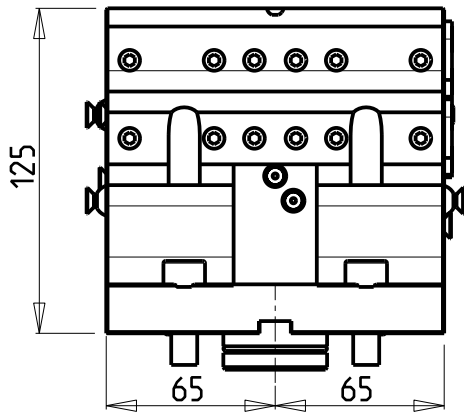
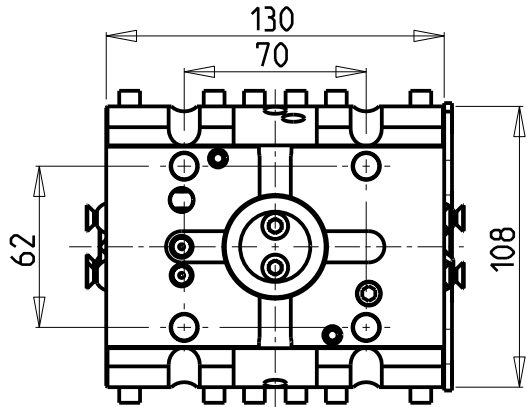

PER BOCCOLE DI RIDUZIONE VEDI PAG. TBL150-1-00
 FOR REDUCING BUSHINGS SEE PAGE TBL150-1-00
 FUER REDUZIERBUCHSE SIEHE SEITE TBL150-1-00

KIT ADDUZIONE INTERNA (OPZIONALE)
 KIT FOR INTERNAL COOLANT (OPTIONAL)
 KIT FUER INTERNE KUEHLMITTELZUFUHR (OPTIONAL)
 Ø25 / Ø1" cod. KIT1000006
 Ø20 cod. KIT1000015
 Ø3/4" cod. KIT1000005

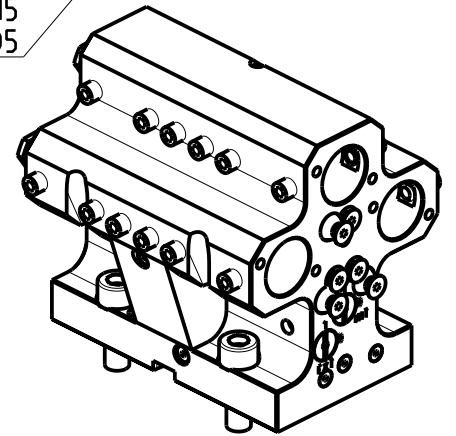
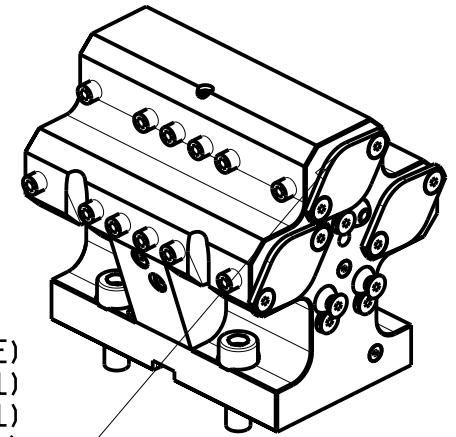

Cod. MT	N°Utensili N°Tools N°Werkzeuge	Reversibile lato mandrino/contromandrino Reversible sub/main spindle side Umkehrbare Spindel-seite/ Gegenspindel-seite	Lubrificazione int. opzionale Coolant through optional Innenkuehlung Optional	Lubrificazione est. Ext. coolant Aussenkuehlung	Misure Dimensions Masse	D	A	B
MNZ0172500	3+3	X	X	X	mm	25	65	30
MNZ0172540	3+3	X	X	X	Inch	1"	63.5	1"1/4
MNZ0172000	3+3	X	X	X	mm	20	65	30
MNZ0171905	3+3	X	X	X	Inch	3/4"	63.5	2"1/2

DMG-MORI

NZ1500/2000 - NZX1500/2000 - NT3100/3150/3200 - NL1500/2000/2500 20 STAZ. - NLX1500/2000/2500 20 STAZ. - NT1000/2000
 NTX1000/2000 - NTX1000/2000/2500/3000 2ND GEN. 12ST. - DURATURN 2050MC/2550MC - ALX1500/2000/2500 - ECOTURN 450 (BMT40)

PORTAUTENSILE ASSIALE PER BARENO 3+3 POSIZIONI Ø25mm / Ø1" / Ø20mm / Ø3/4"

Axial 3+3 position boring bar holder Ø25mm / Ø1" / Ø20mm / Ø3/4"

Axial Bohrhalter 3+3 Positionen Ø25mm / Ø1" / Ø20mm / Ø3/4"

M.T. srl

Via Casino Albini 480
 Tel. 0541/956034-957884
 Fax 0541/956341
 47842 S. GIOVANNI IN M. (RN)
 e-mail: mtma@mtmarchetti.com
 http://www.mtmarchetti.com



PAGINA MNZ914-1-00

Subject to change without notice.

10/2021

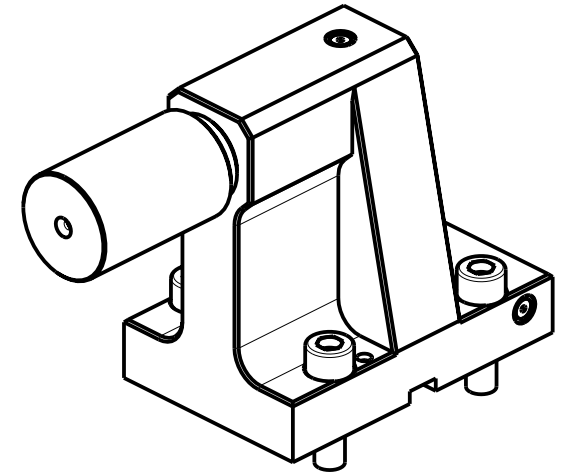
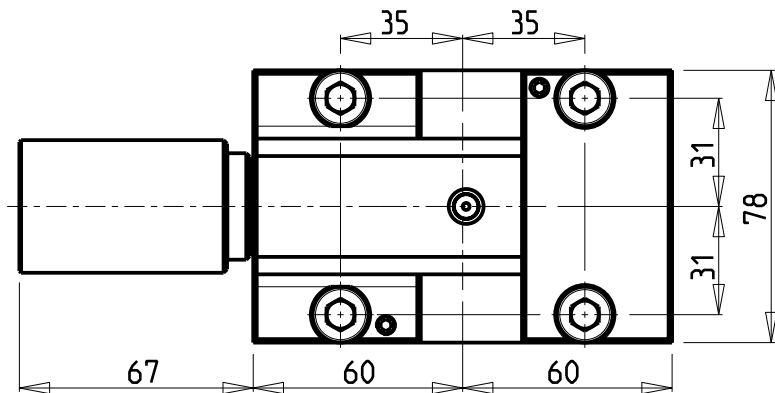
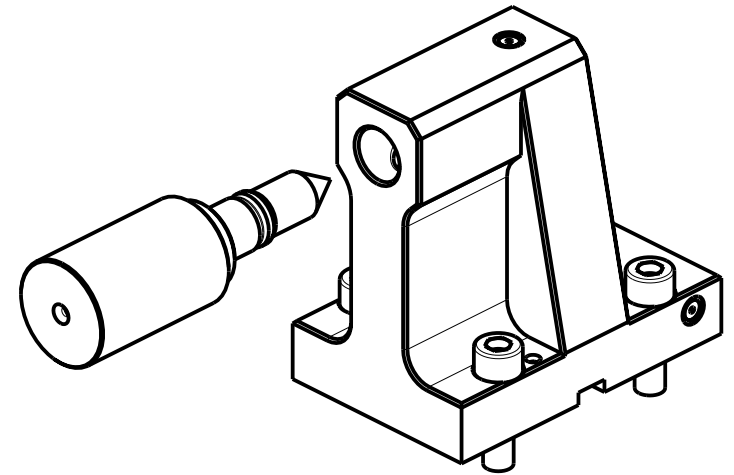
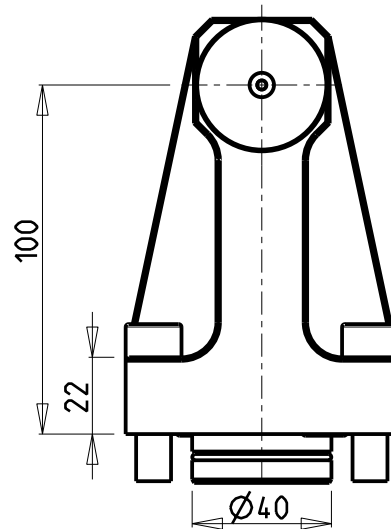
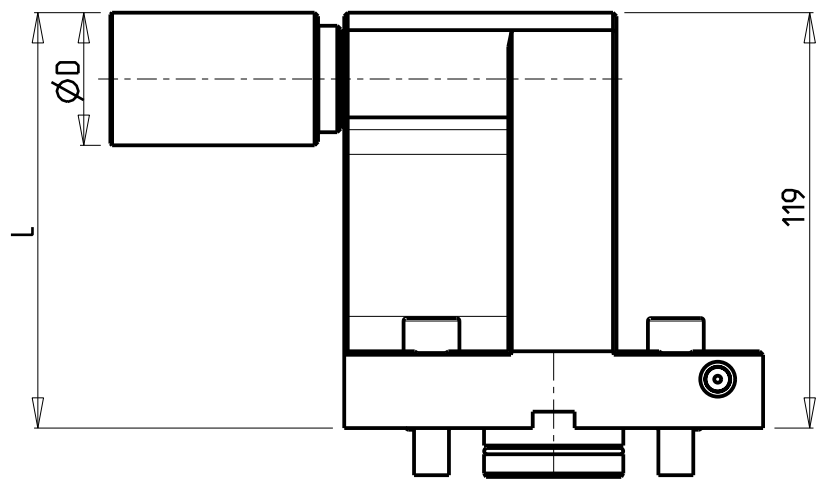

Cod. MT	N° Utensili N° Tools N° Werkzeuge	D	L
MNZ0300100	1	38	119
MNZ0300100L	1	2"	125.4

DMG-MORI

NZ1500/2000 - NZX1500/2000 - NT3100/3150/3200 - NL1500/2000/2500 20 STAZ. - NLX1500/2000/2500 20 STAZ.
 NT1000/2000 - NTX1000/2000 - NTX1000/2000/2500/3000 2ND GEN. 12ST. - DURATURN 2050MC/2550MC - ALX1500/2000/2500

CONTROPUNTA PER CONTROMANDRINO

Tailstock for subspindle

Gegenspintz fuer Gegenspindel

Subject to change without notice.

M.T. srl

Via Casino Albini 480
 Tel. 0541/956034-957884
 Fax 0541/956341
 47842 S. GIOVANNI IN M. (RN)
 e-mail: mtma@mtmarchetti.com
 http://www.mtmarchetti.com



PAGINA MNZ950-1-00

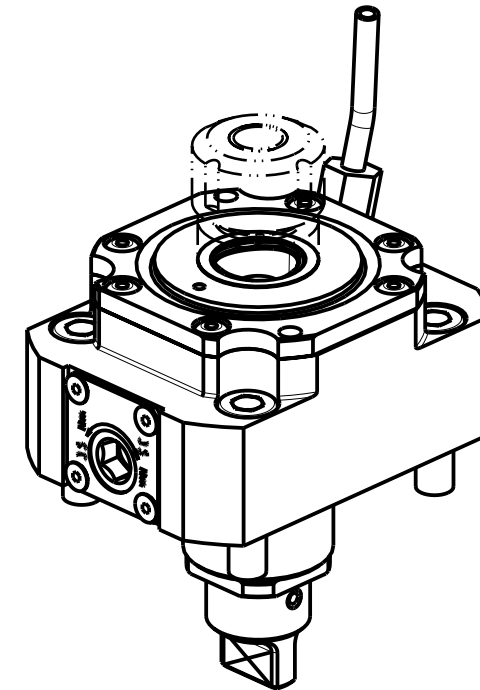
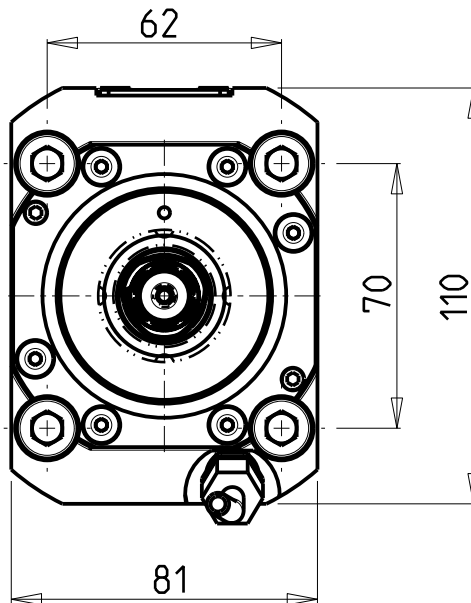
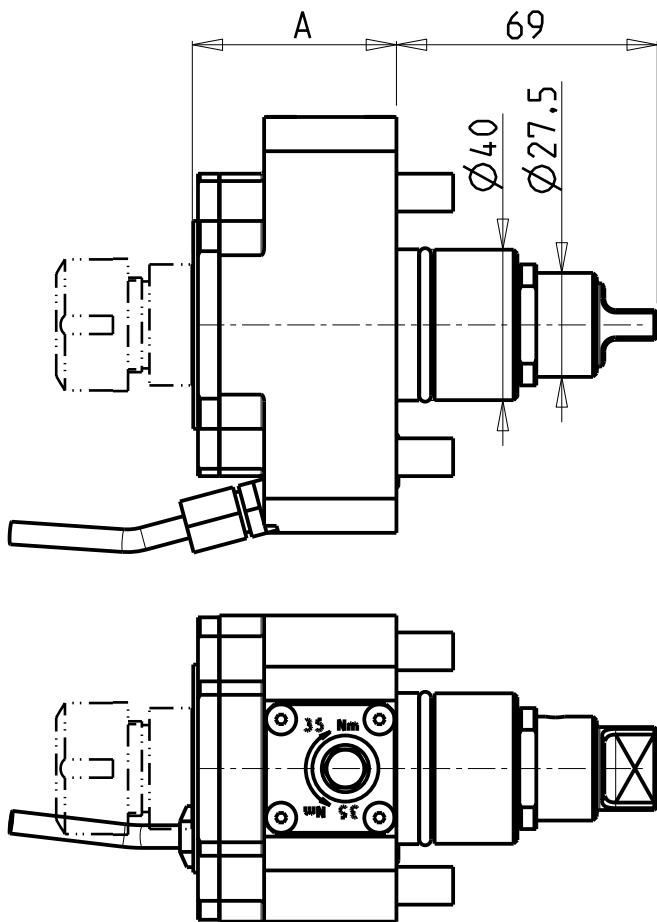

Cod. MT	TAGLIA Size Masse	I	RPM	Coppia Max Max Torque Max Drehmoment	A	Lubr.esterna Ext. coolant Aussenkuehlung
MNZ0330130	C3	1:1	6000	40Nm	54	X
MNZ0330140	C4	1:1	6000	40Nm	63	X

DMG-MORI

NZ1500/2000 - NZX1500/2000 - NZX2500 (BMT40) - NT3100/3150/3200 - NL1500/2000/2500 20 STAZ. - NLX1500/2000/2500 20 STAZ. - NT1000/2000
 NTX1000/2000 - NTX1000/2000/2500/3000 2ND GEN. 12ST. - DURATURN 2050MC/2550MC - NRX2000 - ALX1500/2000/2500 - ECOTURN 450 (BMT40)

MODULO MOTORIZZATO RADIALE MT CAPTO

Radial driven tool MT CAPTO

Radial angetriebenes Werkzeug MT CAPTO

Subject to change without notice.

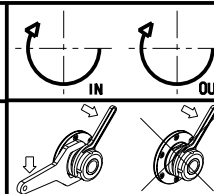

M.T. srl

Via Casino Albini 480
 Tel. 0541/956034-957884
 Fax 0541/956341
 47842 S. GIOVANNI IN M. (RN)
 e-mail: mtma@mtmarchetti.com
 http://www.mtmarchetti.com



PAGINA MNZ010-A-30

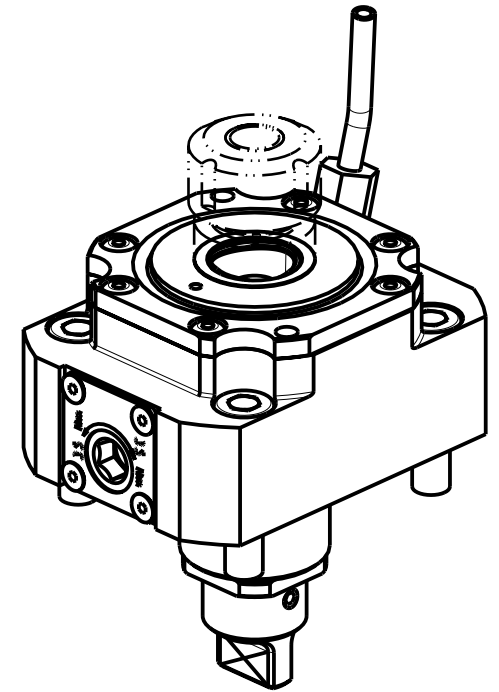
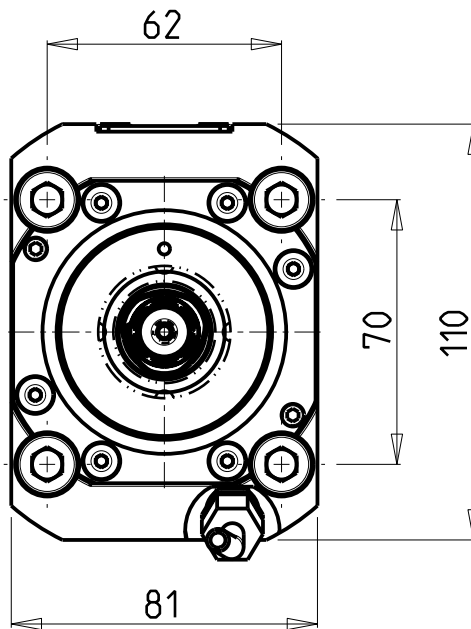
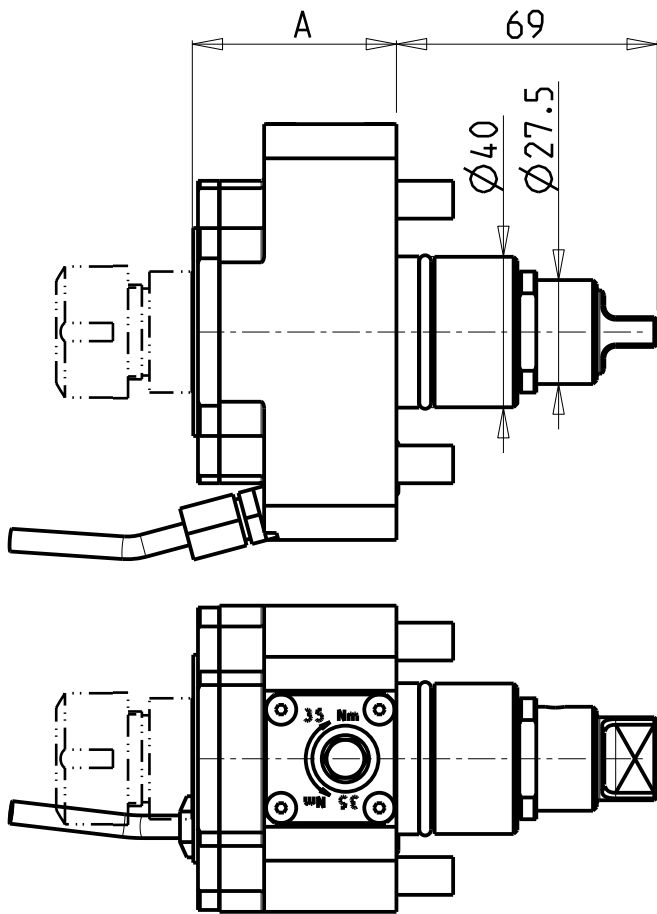

Cod. MT	TAGLIA Size Masse	I	RPM	Coppia Max Max Torque Max Drehmoment	A	Lubr.esterna Ext. coolant Aussenkuehlung
MNZ0500130	C3	1:1	12000	40Nm	54	X
MNZ0500140	C4	1:1	12000	40Nm	63	X

DMG-MORI

NZ1500/2000 - NZX1500/2000 - NZX2500 (BMT40) - NL1500/2000/2500 20 STAZ. - NLX1500/2000/2500 20 STAZ.
 NTX1000/2000 - NTX1000/2000/2500/3000 2ND GEN. 12ST. - NRX2000 - ALX1500/2000/2500

MODULO MOTORIZZATO RADIALE 12000 RPM MT CAPTO

Radial driven tool 12000 rpm MT CAPTO

Radial angetriebenes Werkzeug 12000 rpm MT CAPTO

Subject to change without notice.

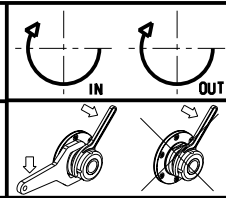

M.T. srl

Via Casino Albini 480
 Tel. 0541/956034-957884
 Fax 0541/956341
 47842 S. GIOVANNI IN M. (RN)
 e-mail: mtma@mtmarchetti.com
 http://www.mtmarchetti.com



PAGINA MNZ010-A-31

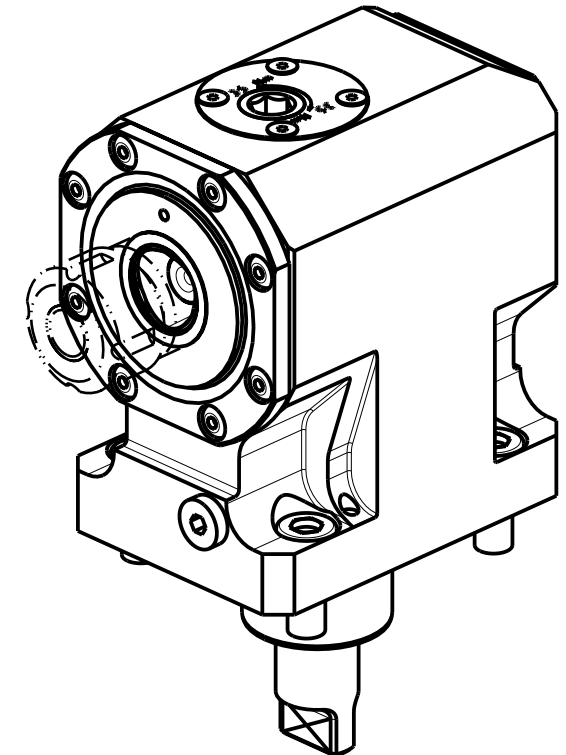
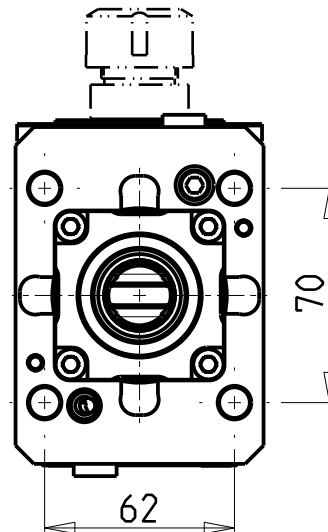
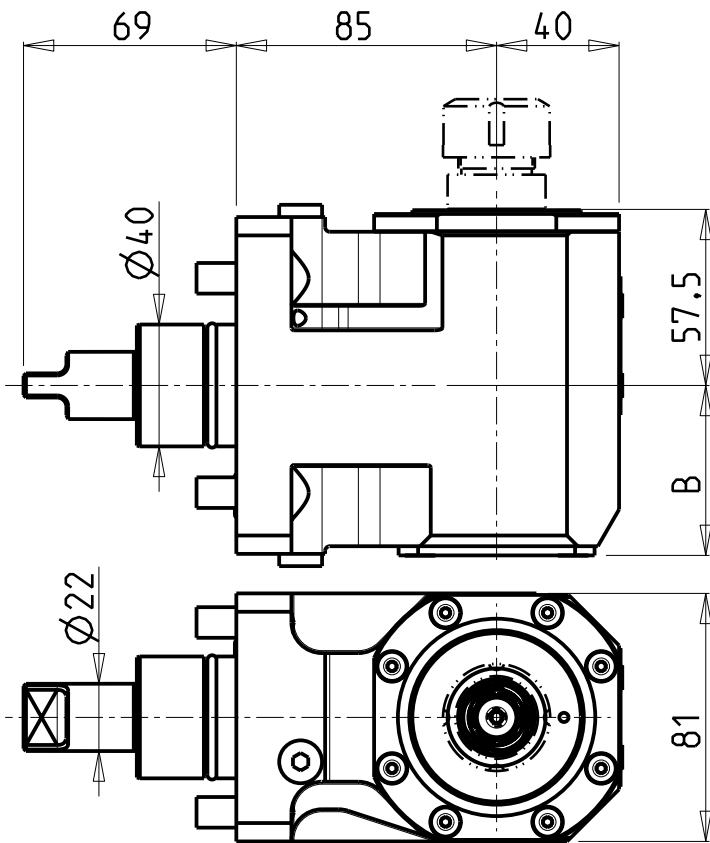

Cod. MT	TAGLIA Size Masse	I	RPM	Coppia Max Max Torque Max Drehmoment	Reversibile lato mandrino/contromandrino Reversible sub/main spindle side Umkehrbare Spindel-seite/ Gegenspindel-seite	Lubr.interna Coolant through Innenkuehlung	Lubr.esterna Ext. coolant Aussenkuehlung	B
MNZ0320130	C3	1:1	6000	40Nm	X	-	X	55.5
MNZ0320230	C3	1:1	6000	40Nm	X	P=70bar	X	68
MNZ0320140	C4	1:1	6000	40Nm	X	-	X	55.5
MNZ0320240	C4	1:1	6000	40Nm	X	P=70bar	X	68

DMG-MORI

NZ1500/2000 - NZX1500/2000 - NZX2500 (BMT40) - NT3100/3150/3200 - NL1500/2000/2500 20 STAZ. - NLX1500/2000/2500 20 STAZ. - NT1000/2000
NTX1000/2000 - NTX1000/2000/2500/3000 2ND GEN. 12ST. - DURATURN 2050MC/2550MC - NRX2000 - ALX1500/2000/2500 - ECOTURN 450 (BMT40)

MODULO MOTORIZZATO ASSIALE MT CAPTO

Axial driven tool MT CAPTO

Axial angetriebenes Werkzeug MT CAPTO

Subject to change without notice.

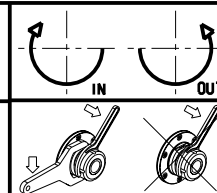

M.T. srl

Via Casino Albini 480
Tel. 0541/956034-957884

Fax 0541/956341

47842 S. GIOVANNI IN M. (RN)

e-mail: mtma@mtmarchetti.com

http://www.mtmarchetti.com



PAGINA MNZ150-A-30

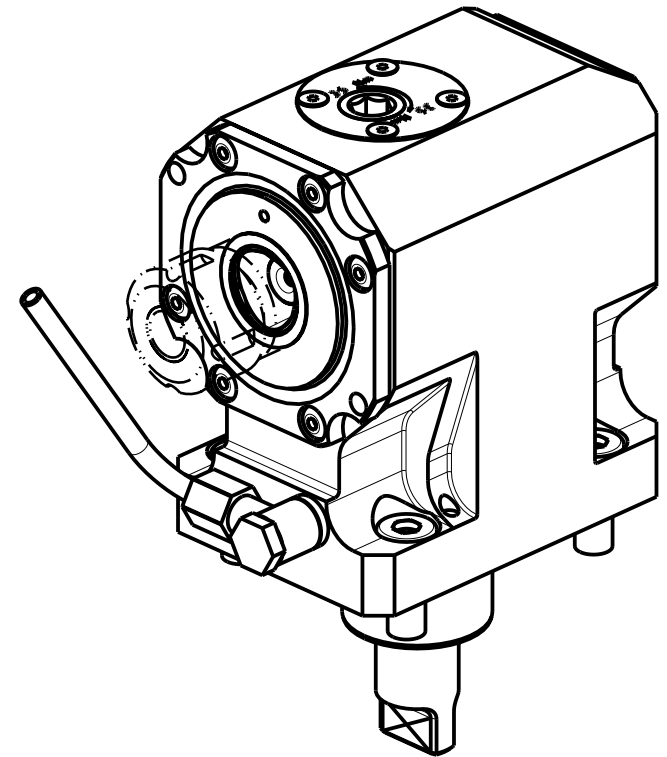
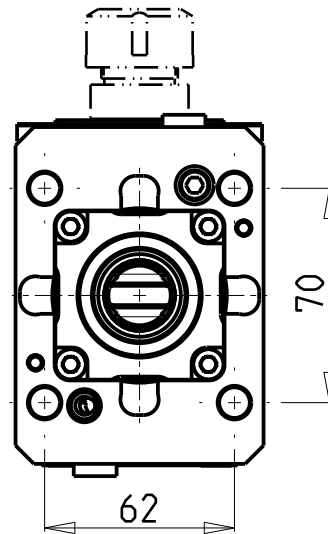
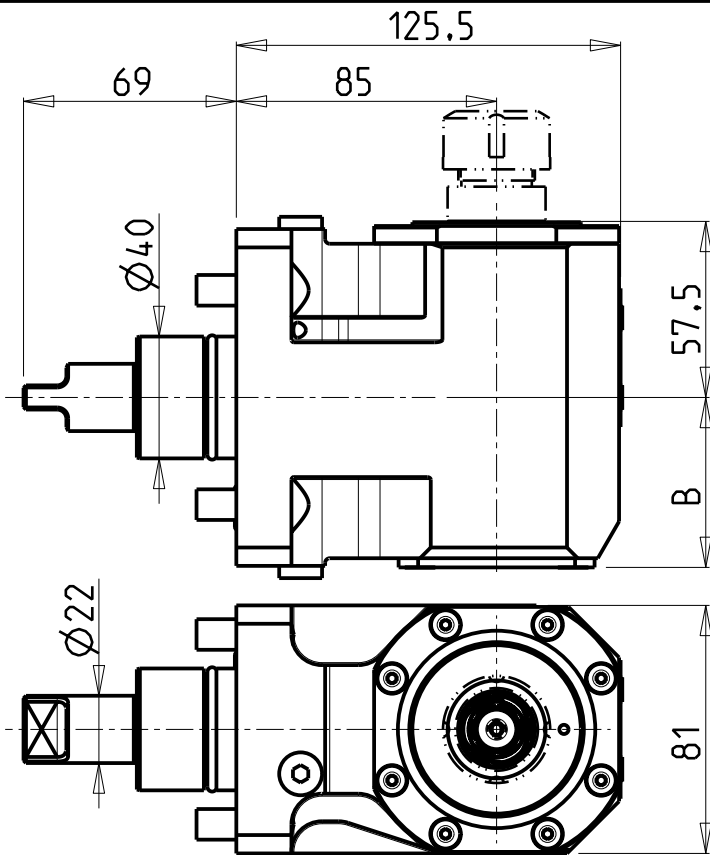

Cod. MT	TAGLIA Size Masse	I	RPM	Coppia Max Max Torque Max Drehmoment	Reversibile lato mandrino/contromandrino Reversible sub/main spindle side Umkehrbare Spindel-seite/ Gegenspindel-seite	Lubr.interna Coolant through Innenkuehlung	Lubr.esterna Ext. coolant Aussenkuehlung	B
MNZ0510130	C3	1:1	12000	40Nm	X	-	X	55.5
MNZ0510230	C3	1:1	12000	40Nm	X	P=70bar	X	68
MNZ0510140	C4	1:1	12000	40Nm	X	-	X	55.5
MNZ0510240	C4	1:1	12000	40Nm	X	P=70bar	X	68

DMG-MORI

NZ1500/2000 - NZX1500/2000 - NZX2500 (BMT40) - NL1500/2000/2500 20 STAZ. - NLX1500/2000/2500 20 STAZ.
 NTX1000/2000 - NTX1000/2000/2500/3000 2ND GEN. 12ST. - NRX2000 - ALX1500/2000/2500

MODULO MOTORIZZATO ASSIALE 12000 RPM MT CAPTO

Axial driven tool 12000 rpm MT CAPTO

Axial angetriebenes Werkzeug 12000 rpm MT CAPTO

Subject to change without notice.

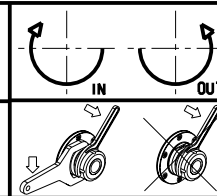

M.T. srl

Via Casino Albini 480
 Tel. 0541/956034-957884
 Fax 0541/956341
 47842 S. GIOVANNI IN M. (RN)
 e-mail: mtma@mtmarchetti.com
 http://www.mtmarchetti.com



PAGINA MNZ150-A-31

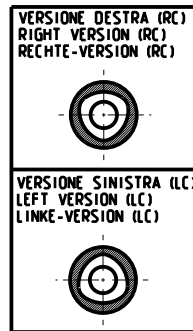
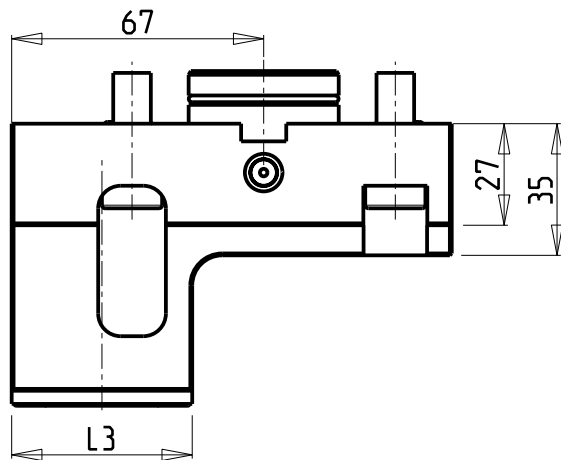
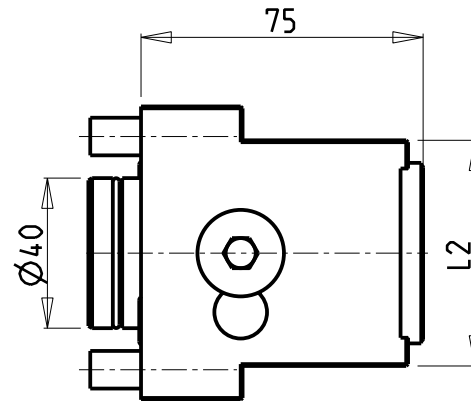
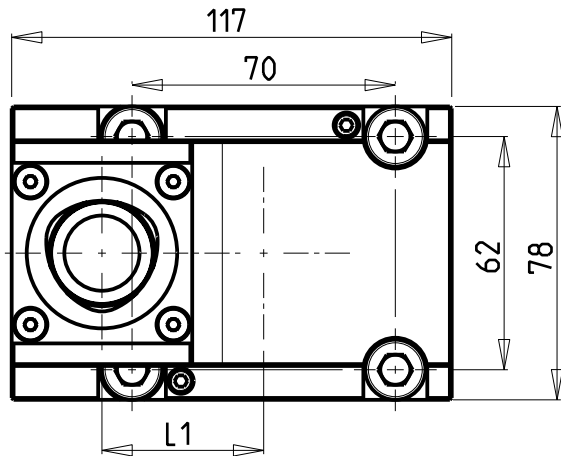

PER ORDINARE LA VERSIONE SX
AGGIUNGERE "LC" AL CODICE IN TABELLA.
ES: MNL0464010 DIVENTA MNL0464010LC

TO ORDER LEFT VERSION
ADD A "LC" IN THE CODE-CHARTS.
EXAMPLE: MNL0464010 BECOMES MNL0464010LC

UM DIE LINKE-VERSION ZU BESTELLEN, BEI DER
ARTIKELBEZEICHNUNG "LC" HINZUFUEGEN.
BEISPIEL: MNL0464010 WIRD DANN MNL0464010LC

MNZ0254010

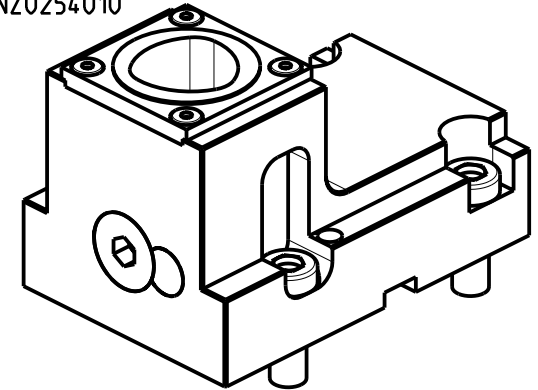

MNZ0253210

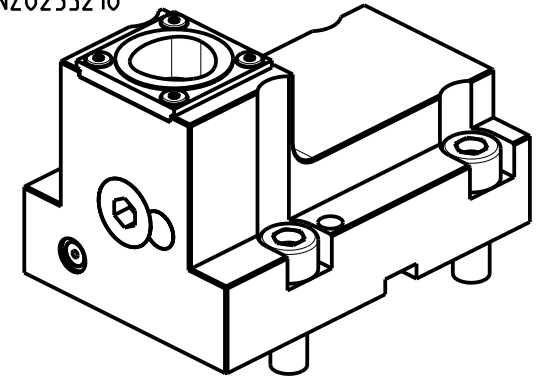

Cod. MT	N°Utensili N°Tools N°Werkzeuge	Lubrificazione int. Coolant through Innenkuehlung	Reversibile lato mandrino/contromandrino Reversible sub/main spindle side Umkehrbare Spindel-seite/ Gegenspindel-seite	TAGLIA Size Masse	L1	L2	L3
MNZ0253210	1	X	X	C3	48	50	43
MNZ0254010	1	X	X	C4	43	60	48

DMG-MORI

NZ1500/2000 - NZX1500/2000 - NZX2500 (BMT40) - NT3100/3150/3200 - NL1500/2000/2500 20 STAZ. - NLX1500/2000/2500 20 STAZ. - NT1000/2000
NTX1000/2000 - NTX1000/2000/2500/3000 2ND GEN. 12ST. - DURATURN 2050MC/2550MC - NRX2000 - ALX1500/2000/2500 - ECOTURN 450 (BMT40)

PORTAUTENSILE RADIALE SINGOLO MT CAPTO

Radial single static tool MT CAPTO

Radial Single-Werkzeughalter MT CAPTO

Subject to change without notice.

M.T. srl

Via Casino Albini 480
Tel. 0541/956034-957884
Fax 0541/956341
47842 S. GIOVANNI IN M. (RN)
e-mail: mtma@tmarchetti.com
http://www.tmmarchetti.com



PAGINA MNZ420-A-40

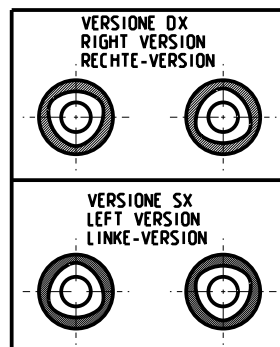
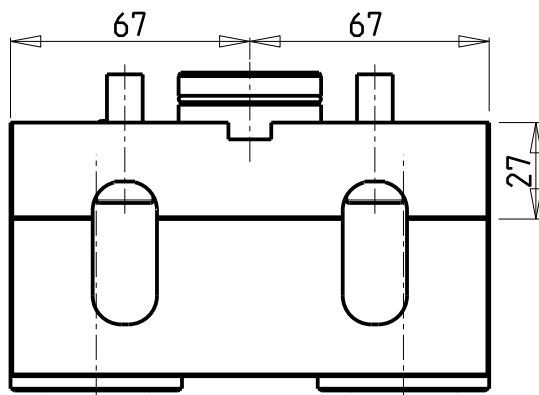
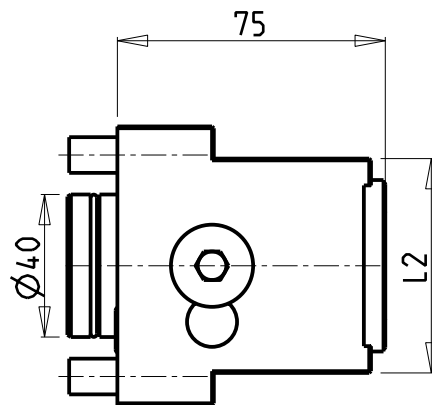
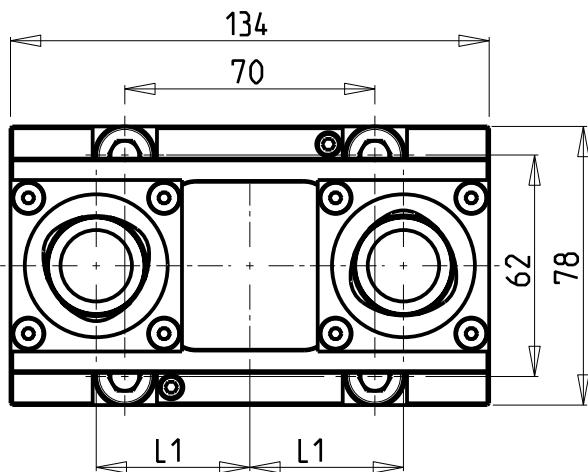

PER ORDINARE LA VERSIONE SX
AGGIUNGERE "LC" AL CODICE IN TABELLA.
ES: MNL0464010 DIVENTA MNL0464010LC

TO ORDER LEFT VERSION
ADD A "LC" IN THE CODE-CHARTS.
EXAMPLE: MNL0464010 BECOMES MNL0464010LC

UM DIE LINKE-VERSION ZU BESTELLEN, BEI DER
ARTIKELBEZEICHNUNG "LC" HINZUFUEGEN.
BEISPIEL: MNL0464010 WIRD DANN MNL0464010LC

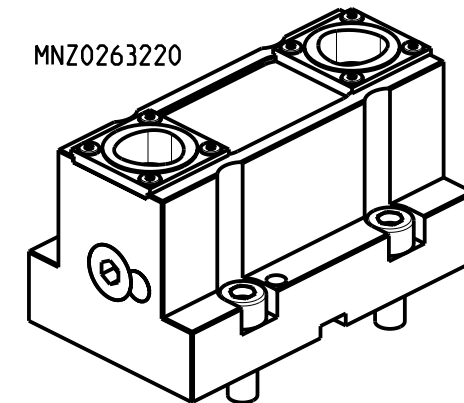
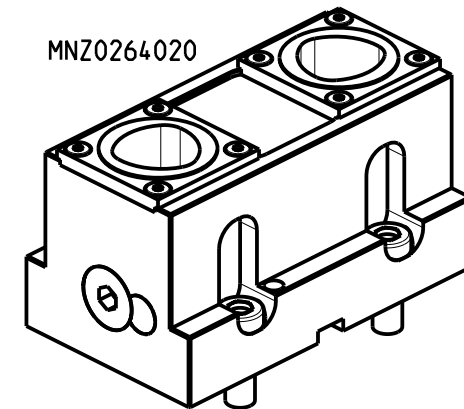

Cod. MT	N°Utensili N°Tools N°Werkzeuge	Lubrificazione int. Coolant through Innenkuehlung	TAGLIA Size Masse	L1	L2
MNZ0263220	2	X	C3	48	50
MNZ0264020	2	X	C4	43	60

DMG-MORI

NZ1500/2000 - NZX1500/2000 - NZX2500 (BMT40) - NT3100/3150/3200 - NL1500/2000/2500 20 STAZ. - NLX1500/2000/2500 20 STAZ. - NT1000/2000
NTX1000/2000 - NTX1000/2000/2500/3000 2ND GEN. 12ST. - DURATURN 2050MC/2550MC - ALX1500/2000/2500 - ECOTURN 450 (BMT40)

PORTAUTENSILE RADIALE DOPPIO MT CAPTO

Radial double static tool MT CAPTO

Radial Doppel-Werkzeughalter MT CAPTO

Subject to change without notice.

M.T. srl

Via Casino Albini 480
Tel. 0541/956034-957884
Fax 0541/956341
47842 S. GIOVANNI IN M. (RN)
e-mail: mtma@mtmarchetti.com
http://www.mtmarchetti.com



PAGINA MNZ450-A-40

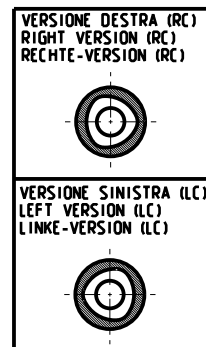
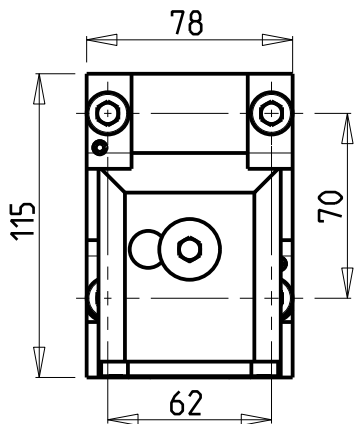
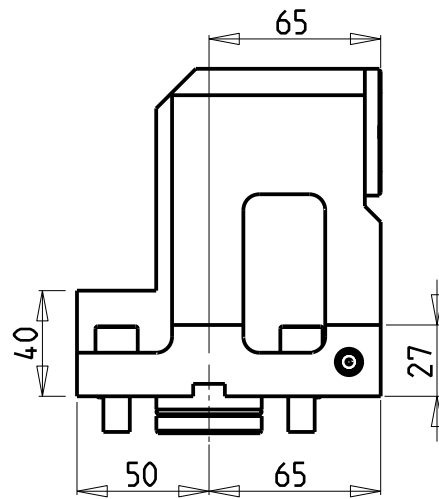
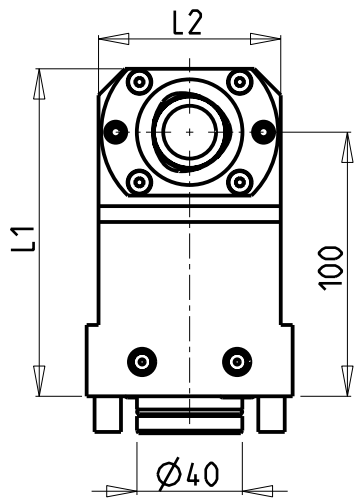

PER ORDINARE LA VERSIONE SX
AGGIUNGERE "LC" AL CODICE IN TABELLA.
ES: MNL0464010 DIVENTA MNL0464010LC

TO ORDER LEFT VERSION
ADD A "LC" IN THE CODE-CHARTS.
EXAMPLE: MNL0464010 BECOMES MNL0464010LC

UM DIE LINKE-VERSION ZU BESTELLEN, BEI DER
ARTIKELBEZEICHNUNG "LC" HINZUFUEGEN.
BEISPIEL: MNL0464010 WIRD DANN MNL0464010LC

MNZ0274010

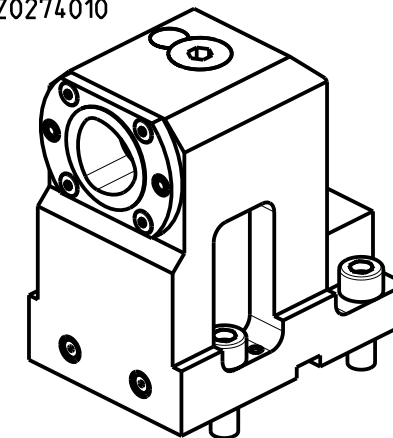

MNZ0273210

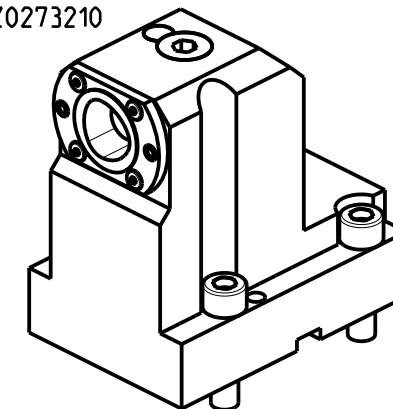

Cod. MT	N°Utensili N°Tools N°Werkzeuge	Lubrificazione int. Coolant through Innenkuehlung	Reversibile lato mandrino/contromandrino Reversible sub/main spindle side Umkehrbare Spindelseite/ Gegenspindelseite	TAGLIA Size Masse	L1	L2
MNZ0273210	1	X	X	C3	119	56
MNZ0274010	1	X	X	C4	124	69

DMG-MORI

NZ1500/2000 - NZX1500/2000 - NZX2500 (BMT40) - NT3100/3150/3200 - NL1500/2000/2500 20 STAZ. - NLX1500/2000/2500 20 STAZ. - NT1000/2000
NTX1000/2000 - NTX1000/2000/2500/3000 2ND GEN. 12ST. - DURATURN 2050MC/2550MC - NRX2000 - ALX1500/2000/2500 - ECOTURN 450 (BMT40)

PORTAUTENSILE ASSIALE SINGOLO MT CAPTO

Axial single static tool MT CAPTO

Axial Single-Werkzeughalter MT CAPTO

Subject to change without notice.

M.T. srl

Via Casino Albini 480
Tel. 0541/956034-957884
Fax 0541/956341
47842 S. GIOVANNI IN M. (RN)
e-mail: mtma@mtmarchetti.com
http://www.mtmarchetti.com



PAGINA MNZ550-A-40

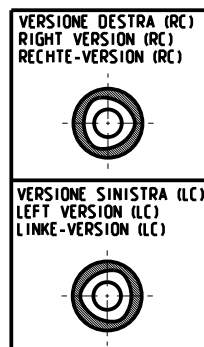
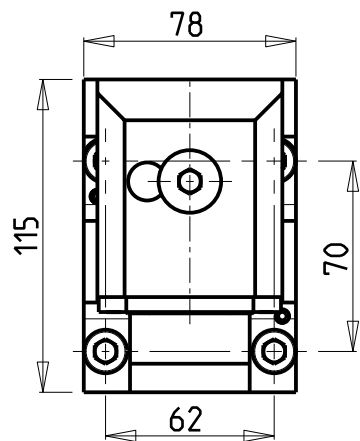
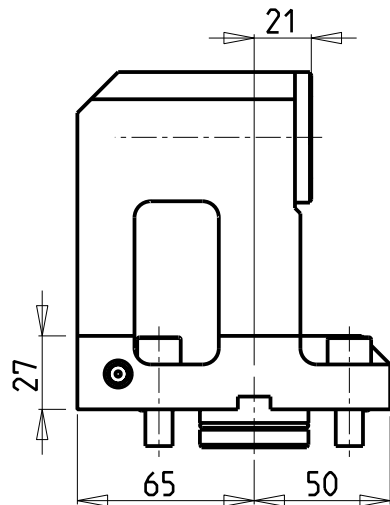
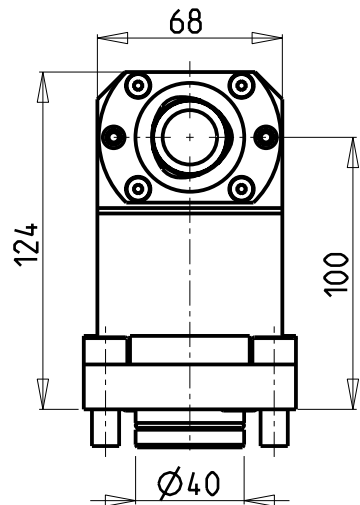

PER ORDINARE LA VERSIONE SX
AGGIUNGERE "LC" AL CODICE IN TABELLA.
ES: MNL0464010 DIVENTA MNL0464010LC

TO ORDER LEFT VERSION
ADD A "LC" IN THE CODE-CHARTS.
EXAMPLE: MNL0464010 BECOMES MNL0464010LC

UM DIE LINKE-VERSION ZU BESTELLEN, BEI DER
ARTIKELBEZEICHNUNG "LC" HINZUFUEGEN.
BEISPIEL: MNL0464010 WIRD DANN MNL0464010LC

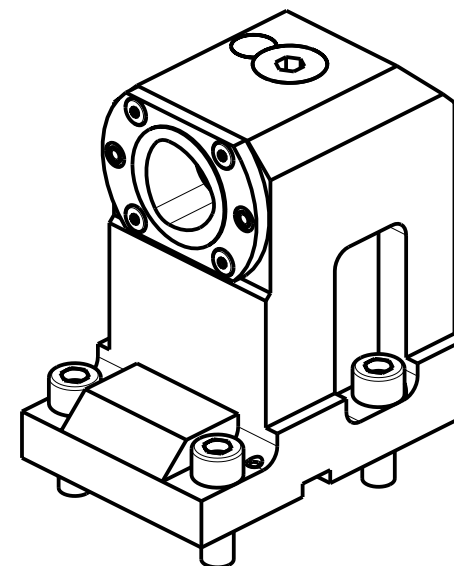

Cod. MT	N°Utensili N°Tools N°Werkzeuge	Lubrificazione int. Coolant through Innenkuehlung	Reversibile lato mandrino/contromandrino Reversible sub/main spindle side Umkehrbare Spindelseite/ Gegenspindelseite	TAGLIA Size Masse
MNZ0294010	1	X	X	C4

DMG-MORI

NZ1500/2000 - NZX1500/2000 - NZX2500 (BMT40) - NT3100/3150/3200 - NL1500/2000/2500 20 STAZ. - NLX1500/2000/2500 20 STAZ. - NT1000/2000
NTX1000/2000 - NTX1000/2000/2500/3000 2ND GEN. 12ST. - DURATURN 2050MC/2550MC - NRX2000 - ALX1500/2000/2500 - ECOTURN 450 (BMT40)

PORTAUTENSILE ASSIALE SINGOLO ARRETRATO MT CAPTO

Axial single rear-set boring static tool MT CAPTO

Axial Single-Werkzeughalter zurueckversetzt MT CAPTO

Subject to change without notice.

M.T. srl

Via Casino Albini 480
Tel. 0541/956034-957884
Fax 0541/956341
47842 S. GIOVANNI IN M. (RN)
e-mail: mtma@mtmarchetti.com
http://www.mtmarchetti.com



PAGINA MNZ555-A-40

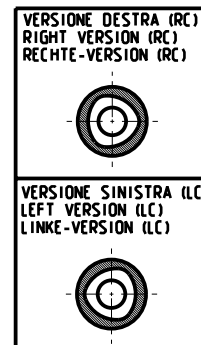
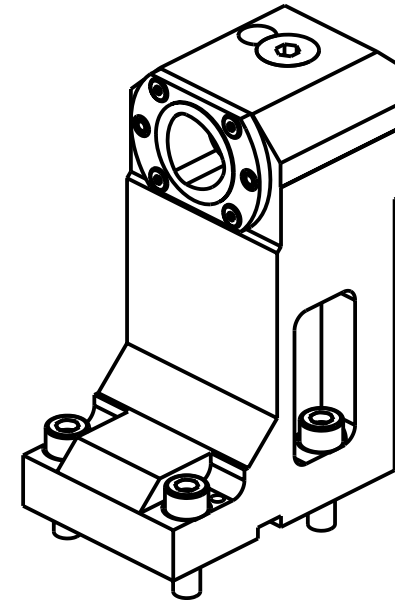
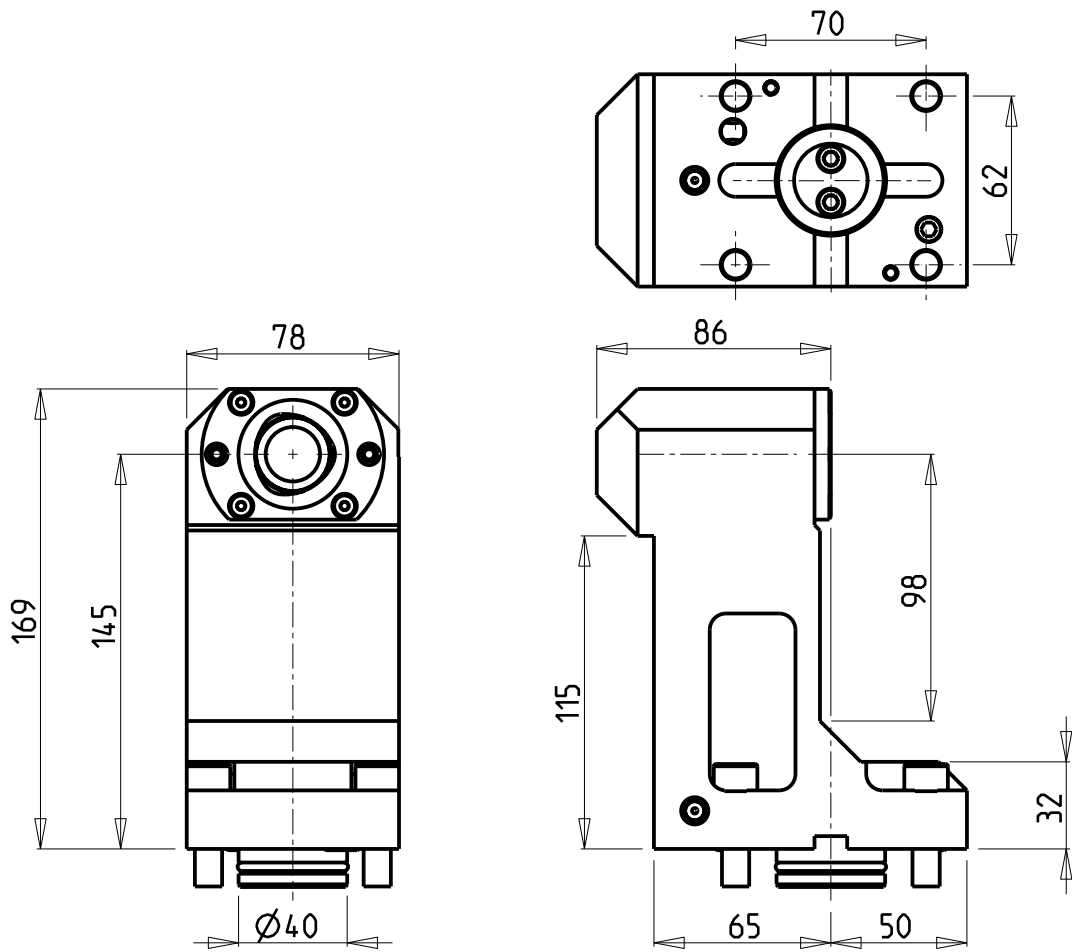

PER ORDINARE LA VERSIONE SX
AGGIUNGERE "LC" AL CODICE IN TABELLA.
ES: MNZ0604010 DIVENTA MNZ0604010LC

TO ORDER LEFT VERSION
ADD A "LC" IN THE CODE-CHARTS.
EXAMPLE: MNZ0604010 BECOMES MNZ0604010LC

UM DIE LINKE-VERSION ZU BESTELLEN, BEI DER
ARTIKELBEZEICHNUNG "LC" HINZUFUEGEN.
BEISPIEL: MNZ0604010 WIRD DANN MNZ0604010LC

Cod. MT	Lubrificazione int. Coolant through Innenkuehlung	Reversibile lato mandrino/contromandrino Reversible sub/main spindle side Umkehrbare Spindelseite/ Gegenspindelseite	TAGLIA Size Masse
MNZ0604010	X	X	C4

DMG-MORI
NTX1000 - NTX2000/2500/3000 2ND GEN. 12ST.

PORTAUTENSILE ASSIALE SINGOLO ARRETRATO MT CAPTO
Axial single rear-set boring static tool MT CAPTO
Axial Single-Werkzeughalter zurueckversetzt MT CAPTO

Subject to change without notice.

M.T. srl
Via Casino Albini 480
Tel. 0541/956034-957884
Fax 0541/956341
47842 S. GIOVANNI IN M. (RN)
e-mail: mtma@mtmarchetti.com
http://www.mtmarchetti.com



PAGINA MNZ556-A-40

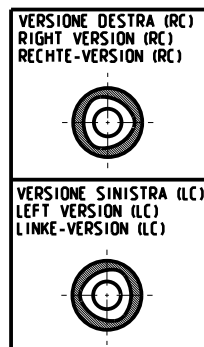
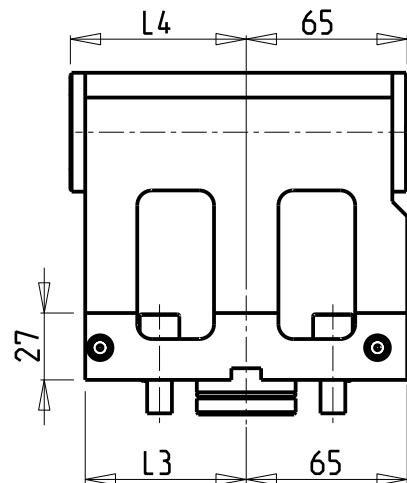
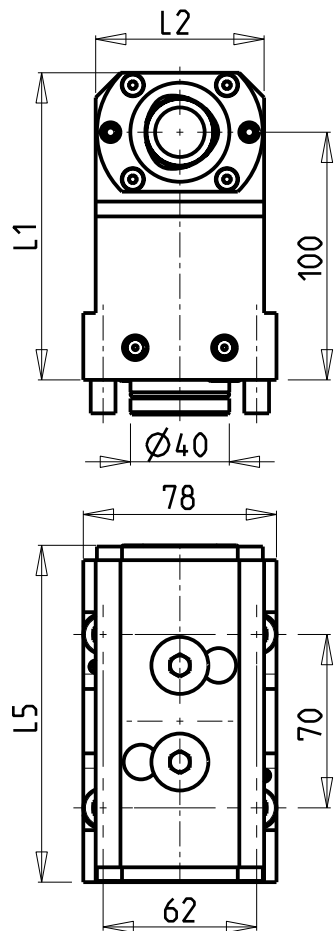

PER ORDINARE LA VERSIONE SX
AGGIUNGERE "LC" AL CODICE IN TABELLA.
ES: MNL0464010 DIVENTA MNL0464010LC

TO ORDER LEFT VERSION
ADD A "LC" IN THE CODE-CHARTS.
EXAMPLE: MNL0464010 BECOMES MNL0464010LC

UM DIE LINKE-VERSION ZU BESTELLEN, BEI DER
ARTIKELBEZEICHNUNG "LC" HINZUFUEGEN.
BEISPIEL: MNL0464010 WIRD DANN MNL0464010LC

MNZ0284020

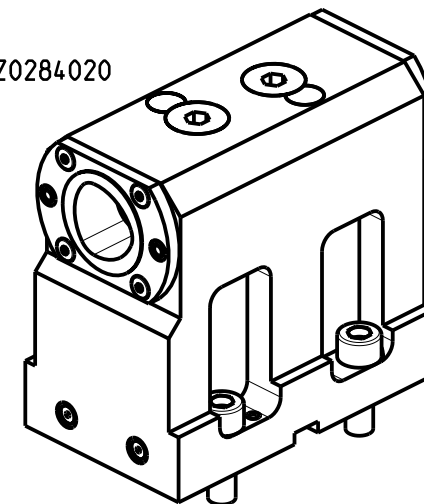

MNZ0283220

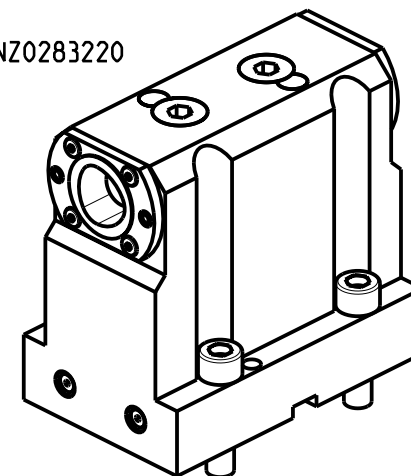

Cod. MT	N°Utensili N°Tools N°Werkzeuge	Lubrificazione int. Coolant through Innenkuehlung	Reversibile lato mandrino/contromandrino Reversible sub/main spindle side Umkehrbare Spindel-seite/ Gegenspindel-seite	TAGLIA Size Masse	L1	L2	L3	L4	L5
MNZ0283220	1+1	X	X	C3	119	56	60	60	125
MNZ0284020	1+1	X	X	C4	124	68	65	71	136

DMG-MORI

NZ1500/2000 - NZX1500/2000 - NT3100/3150/3200 - NL1500/2000/2500 20 STAZ. - NLX1500/2000/2500 20 STAZ.
ALX1500/2000/2500 - ECOTURN 450 (BMT40)

PORTAUTENSILE ASSIALE BISPORGENTE MT CAPTO

Axial opposite face twin static tool MT CAPTO

Axial Halter halb vorspringend mit MT CAPTO

Subject to change without notice.

M.T. srl

Via Casino Albini 480
Tel. 0541/956034-957884
Fax 0541/956341
47842 S. GIOVANNI IN M. (RN)
e-mail: mtma@mtmarchetti.com
http://www.mtmarchetti.com

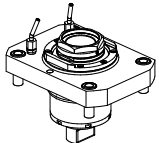
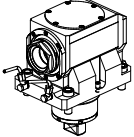

PAGINA MNZ570-A-40

		PAGINA Page Seite
MODULO MOTORIZZATO RADIALE MTSK Radial MTSK driven tool Radial MTSK angetriebenes Werkzeug		NZL010.1.00.K
MODULO MOTORIZZATO ASSIALE MTSK Axial MTSK driven tool Axial MTSK angetriebenes Werkzeug		NZL150.1.10.K

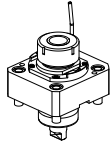
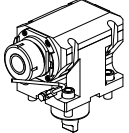
		PAGINA Page Seite
MODULO MOTORIZZATO RADIALE Radial driven tool Radial angetriebenes Werkzeug		NZL010.2.00
MODULO MOTORIZZATO ASSIALE Axial driven tool Axial angetriebenes Werkzeug		NZL150.2.10

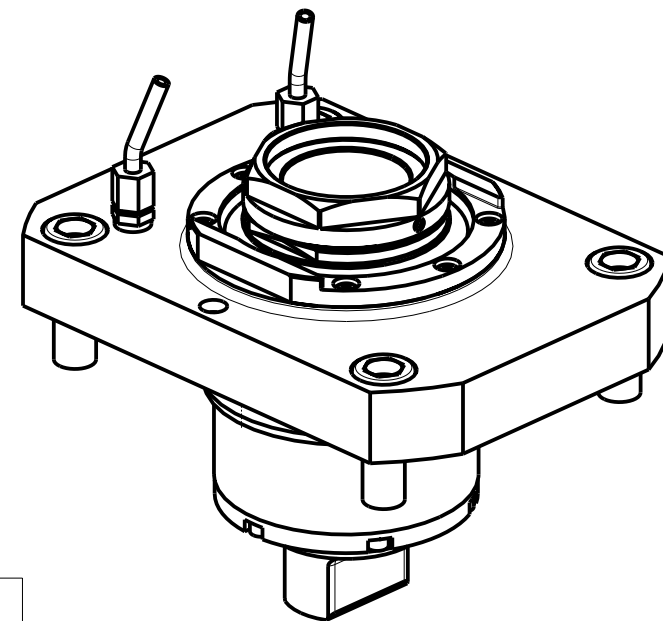
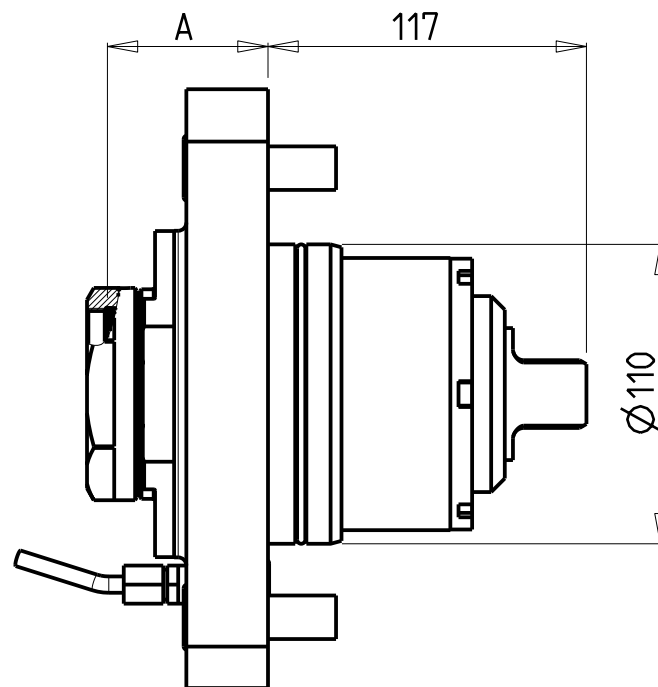
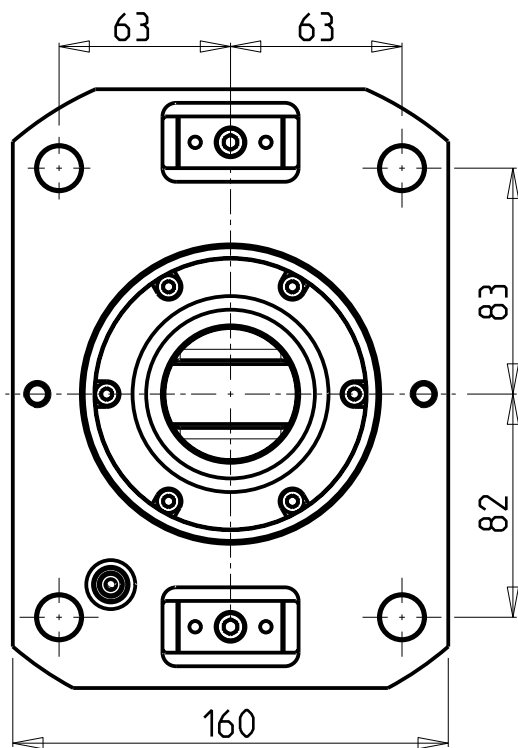

PER PORTAUTENSILI MODULARI MTSK-63 VEDI PAG. TBL300-1-63
 FOR MTSK-63 QUICK CHANGE TOOLHOLDERS CLAMPINGS SEE PAGE TBL300-1-63
 FUER MTSK-63 MODULARE WERKZEUGAUFNAHMEN SIEHE SEITE TBL300-1-63

Cod. MT	Mandrino Spindle Spindel	I	RPM MAX	Coppia Max Max Torque Max Drehmoment	Lubr.interna Coolant through Innenkuehlung	Lubrificazione est. Ext. coolant Aussenkuehlung	A	CHIAVI NON INCLUSE Keys not included Schlüssel nicht einbegriffen	
NZL0020163	MTSK-63	1:1	3500	200Nm		X	59	CHUB68	NZL0010023 *
NZL0020263	MTSK-63	1:1	3500	200Nm	P=70bar	X	69	CHUB68	NZL0010023 *
NZL0020363	MTSK-63	1:1	6500	200Nm		X	59	CHUB68	NZL0010023 *
NZL0020463	MTSK-63	1:1	6500	200Nm	P=70bar	X	69	CHUB68	NZL0010023 *

- Chiave inclusa
- Key included
- Schlüssel inbegriffen

DMG-MORI

MOD: NZL6000 - NZX6000

MODULO MOTORIZZATO RADIALE MTSK
 Radial MTSK driven tool
 Radial MTSK angetriebenes Werkzeug

Subject to change without notice.

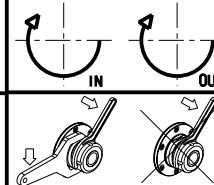

M.T. srl
 Via Casino Albini 480
 Tel. 0541/956034-957884
 Fax 0541/956341
 47842 S. GIOVANNI IN M. (RN)
 e-mail: mtma@mtmarchetti.com
 http://www.mtmarchetti.com



PAGINA NZL010-1-00-K

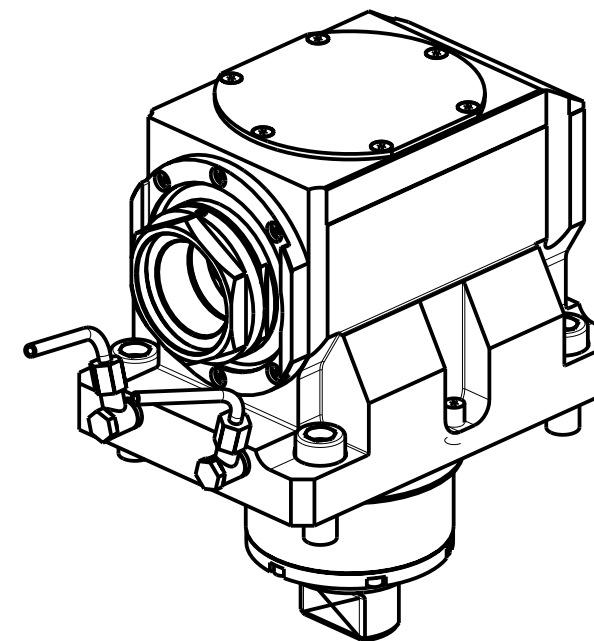
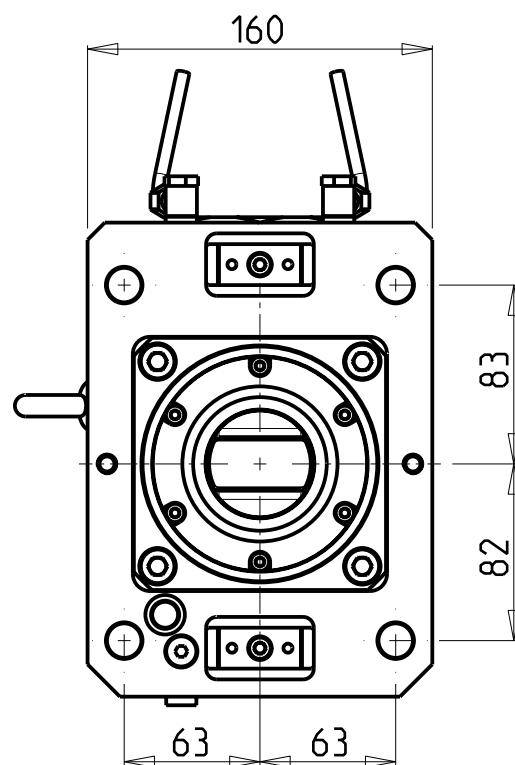
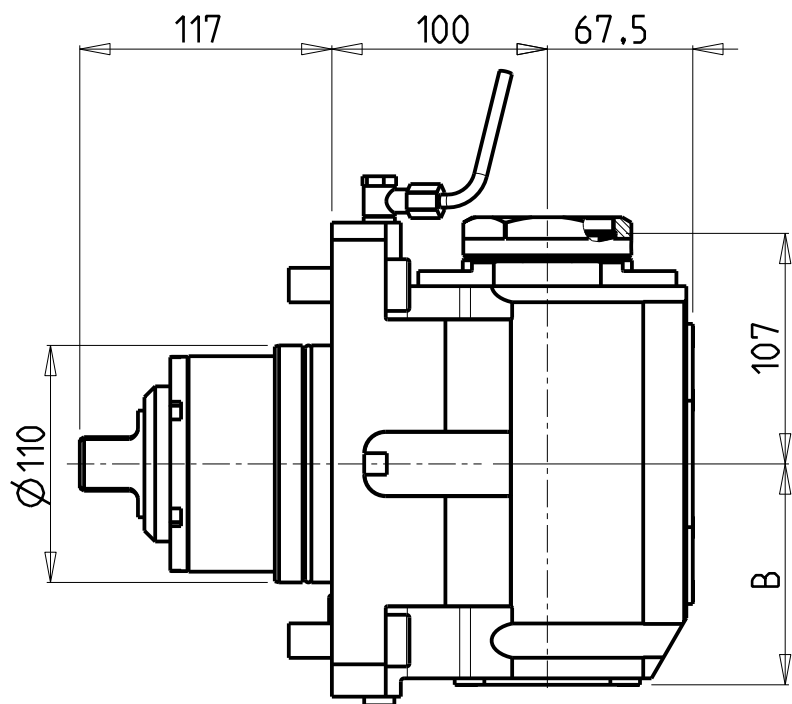

PER PORTAUTENSILI MODULARI MTSK-63 VEDI PAG. TBL300-1-63
 FOR MTSK-63 QUICK CHANGE TOOLHOLDERS CLAMPINGS SEE PAGE TBL300-1-63
 FUER MTSK-63 MODULARE WERKZEUGAUFNAHMEN SIEHE SEITE TBL300-1-63

Cod. MT	Mandrino Spindle Spindel	i	RPM MAX	Coppia Max Max Torque Max Drehmoment	Lubr.interna Coolant through Innenkuehlung	Lubr.esterna Ext. coolant Aussenkuehlung	B	CHIAVI NON INCLUSE Keys not included Schlüssel nicht einbegriffen	
NZL0010163	MTSK-63	1:1	3500	200Nm		X	102.5	CHUB68	NZL0010023 *
NZL0010263	MTSK-63	1:1	3500	200Nm	P=70bar	X	119	CHUB68	NZL0010023 *
NZL0010363	MTSK-63	1:1	6500	200Nm		X	102.5	CHUB68	NZL0010023 *
NZL0010463	MTSK-63	1:1	6500	200Nm	P=70bar	X	119	CHUB68	NZL0010023 *

- Chiave inclusa
- Key included
- Schlüssel inbegriffen

DMG-MORI
 MOD: NZL6000 - NZX6000

MODULO MOTORIZZATO ASSIALE MTSK
 Axial MTSK driven tool
 Axial MTSK angetriebenes Werkzeug

Subject to change without notice.

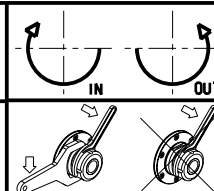

M.T. srl
 Via Casino Albini 480
 Tel. 0541/956034-957884
 Fax 0541/956341
 47842 S. GIOVANNI IN M. (RN)
 e-mail: mtma@tmarchetti.com
 http://www.tmmarchetti.com



PAGINA NZL150-1-10-K

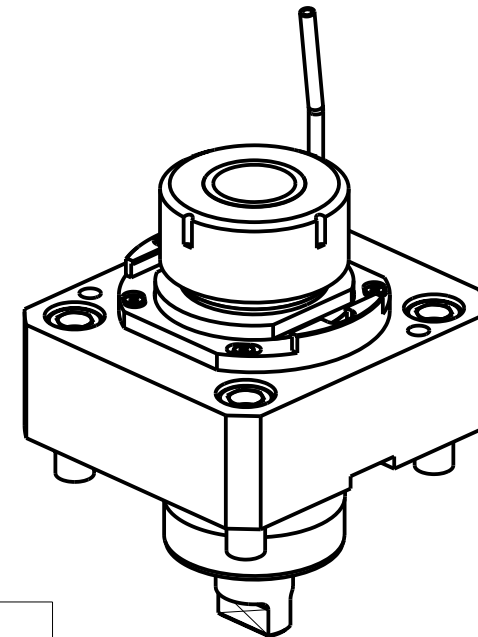
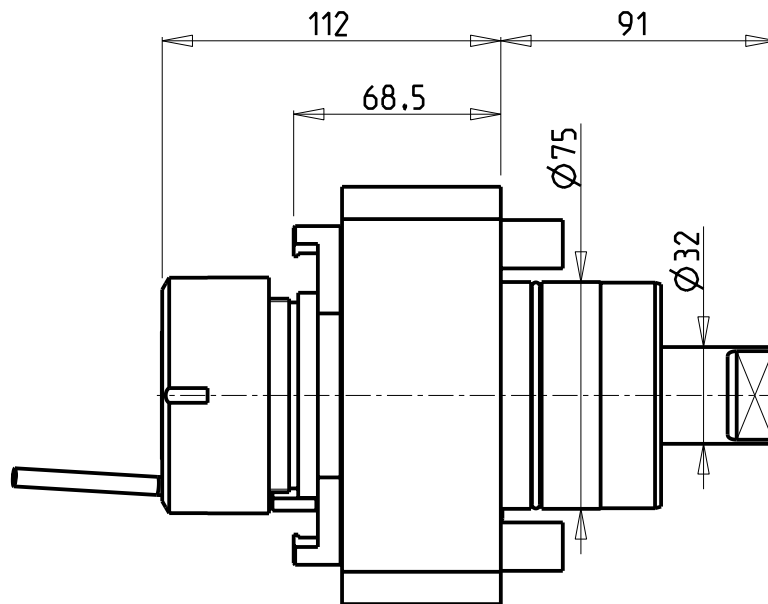
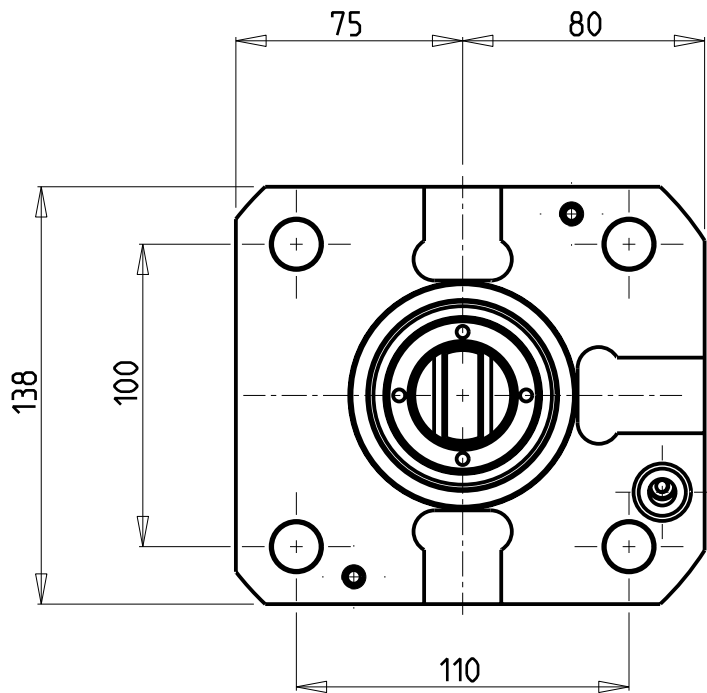

- Chiave inclusa
- Key included
- Schluessel inbegriffen

Cod. MT	Mandrino Spindle Spindel	I	RPM	Coppia Max Max Torque Max Drehmoment	Lubrificazione est. Ext. coolant Aussenkuehlung	CHIAVI NON INCLUSE Keys not included Schluessel nicht einbegriffen	
NZL0060150	ER50	1:1	8000	150Nm	X	CHSTER50	NZL0010023 ■

DMG-MORI
 MOD: NLX6000 - NZX4000
 MODULO MOTORIZZATO RADIALE
 Radial driven tool
 Radial angetriebenes Werkzeug
 Subject to change without notice.

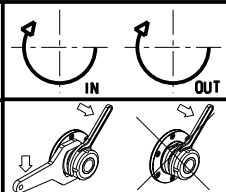

M.T. srl
 Via Casino Albini 480
 Tel. 0541/956034-957884
 Fax 0541/956341
 47842 S. GIOVANNI IN M. (RN)
 e-mail: mtma@mtmarchetti.com
 http://www.mtmarchetti.com



PAGINA NZL010-2-00

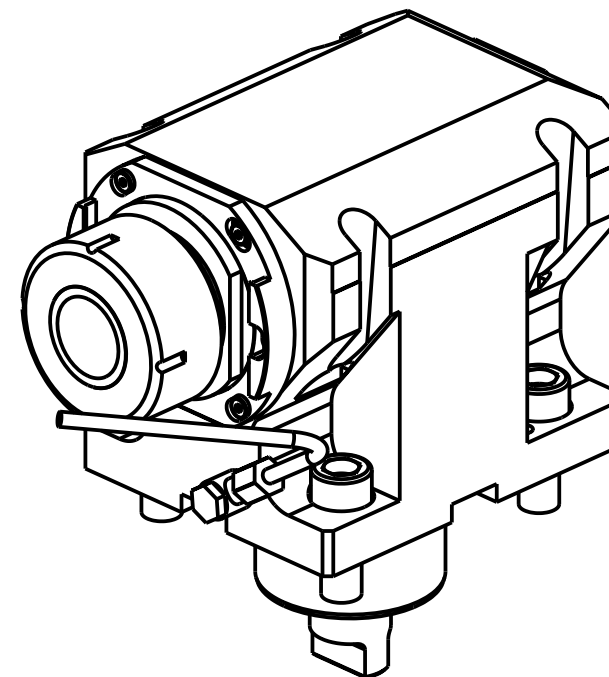
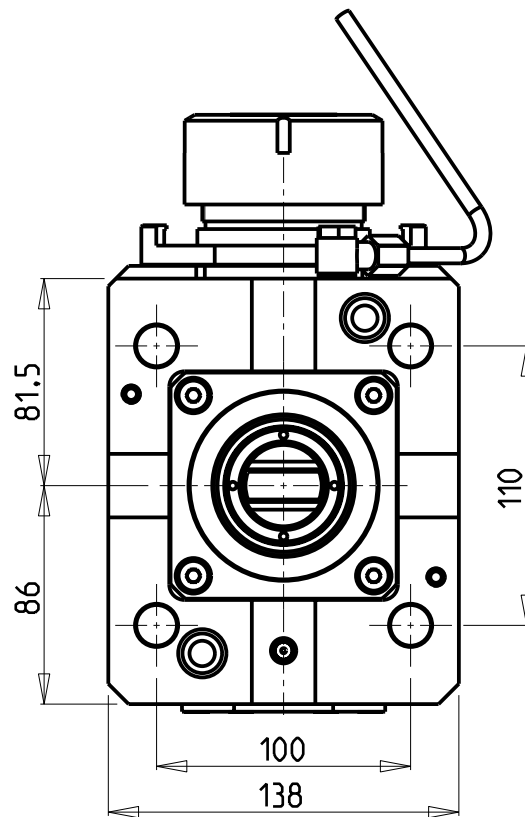
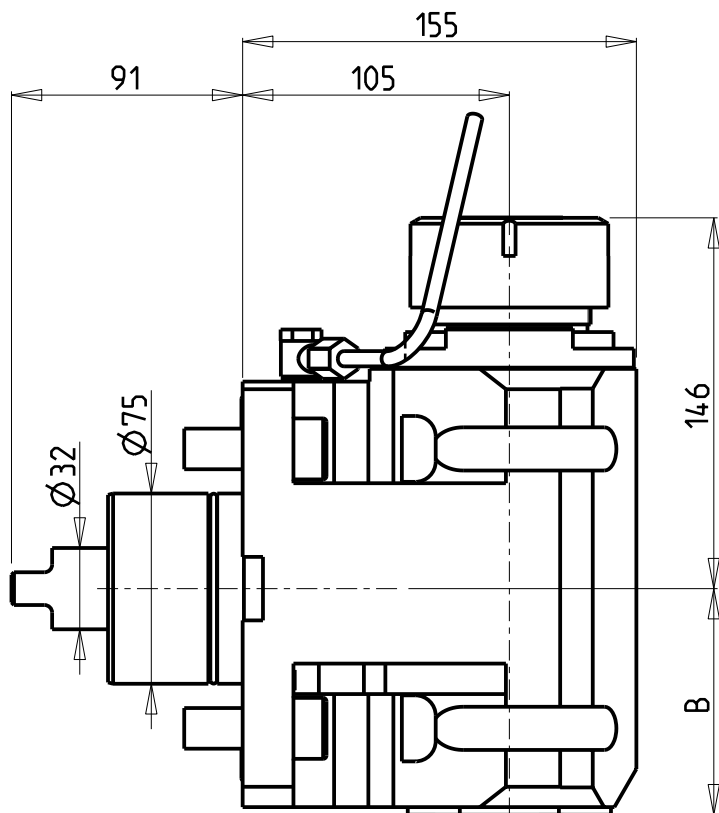

- Chiave inclusa
- Key included
- Schlüssel inbegriffen

Cod. MT	Mandrino Spindle Spindel	I	RPM	Coppia Max Max Torque Max Drehmoment	Reversibile lato mandrino/contromandrino Reversible sub/main spindle side Umkehrbare Spindel-seite/ Gegenspindel-seite	Lubrificazione int. Coolant through Innenkuehlung	Lubrificazione est. Ext. coolant Aussenkuehlung	B	CHIAVI NON INCLUSE Keys not included Schlüssel nicht einbegriffen	
NZL0070150	ER50	1:1	8000	150Nm	X	-	X	89	CHSTER50	NZL0010023 •
NZL0070250	ER50	1:1	8000	150Nm	X	P=70bar	X	105.5	CHSTER50	NZL0010023 •

DMG-MORI

MOD: NLX6000 - NZX4000

MODULO MOTORIZZATO ASSIALE H=105mm

Axial driven tool H=105mm

Axial angetriebenes Werkzeug H=105mm

Subject to change without notice.

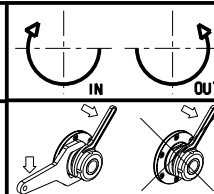

M.T. srl

Via Casino Albini 480
Tel. 0541/956034-957884
Fax 0541/956341
47842 S. GIOVANNI IN M. (RN)
e-mail: mtma@mtmarchetti.com
http://www.mtmarchetti.com

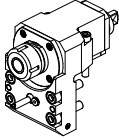
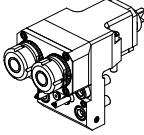
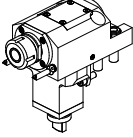
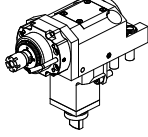
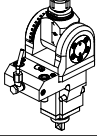
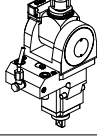
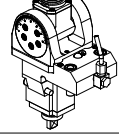
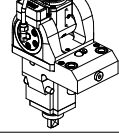
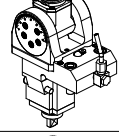
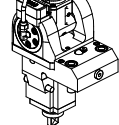

PAGINA NZL150-2-10

		PAGINA Page Seite
<p>MODULO MOTORIZZATO RADIALE Radial driven tool Radial angetriebenes Werkzeug</p>		MSL010.1.00
<p>MODULO MOTORIZZATO RADIALE 2 USCITE IN Y Radial single side twin head driven tool in Y Radial angetriebenes Werkzeug 2 Ausgange in Y</p>		MSL080.1.00
<p>MODULO MOTORIZZATO ASSIALE Axial driven tool Axial angetriebenes Werkzeug</p>		MSL150.1.10
<p>MODULO MOTORIZZATO ASSIALE MOLTIPLICATO I = 1:5.625 Axial geared-up I=1:5.625 driven tool Axial angetriebenes Werkzeug uebersetzt I=1:5.625</p>		MSL210.1.10
<p>MODULO MOTORIZZATO ORIENTABILE $\pm 90^\circ$ $\pm 90^\circ$ adjustable angle driven tool Angetriebenes Werkzeug schwenkbar $\pm 90^\circ$</p>		MSL333.1.00
<p>MODULO MOTORIZZATO ORIENTABILE $\pm 90^\circ$ CON NONIO DIGITALE $\pm 90^\circ$ adjustable angle driven tool with digital display Angetriebenes Werkzeug schwenkbar $\pm 90^\circ$ mit digital display</p>		MSL333.1.01
<p>MODULO MOTORIZZATO ORIENTABILE $\pm 90^\circ$ $\pm 90^\circ$ adjustable angle driven tool Angetriebenes Werkzeug schwenkbar $\pm 90^\circ$</p>		MSL335.1.00
<p>MODULO MOTORIZZATO ORIENTABILE $\pm 90^\circ$ CON NONIO DIGITALE $\pm 90^\circ$ adjustable angle driven tool with digital display Angetriebenes Werkzeug schwenkbar $\pm 90^\circ$ mit digital display</p>		MSL335.1.01
<p>MODULO MOTORIZZATO ORIENTABILE $\pm 90^\circ$ MOLTIPLICATO I=1:2 $\pm 90^\circ$ adjustable angle driven tool geared-up I=1:2 Angetriebenes Werkzeug schwenkbar $\pm 90^\circ$ uebersetzt I=1:2</p>		MSL336.1.00
<p>MODULO MOTOR. ORIENTAB. $\pm 90^\circ$ MOLTIPL. I=1:2 CON NONIO DIGITALE $\pm 90^\circ$ adjustable angle driven tool geared-up I=1:2 with digital display Angetriebenes Werkzeug schwenkbar $\pm 90^\circ$ uebersetzt I=1:2 mit digital display</p>		MSL336.1.01

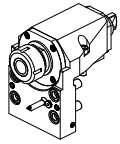
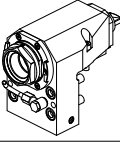
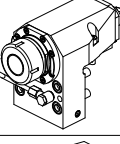
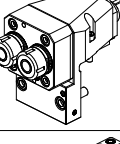
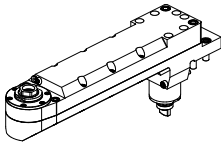
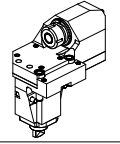
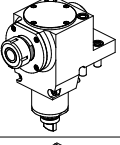
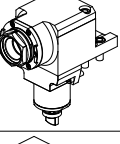
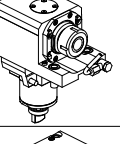
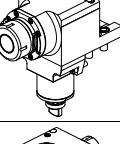
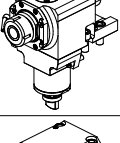
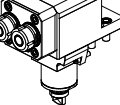
		PAGINA Page Seite
<p>MODULO MOTORIZZATO RADIALE</p> <p>Radial driven tool</p> <p>Radial angetriebenes Werkzeug</p>		MSL010.2.00
<p>MODULO MOTORIZZATO RADIALE MTSK</p> <p>Radial MTSK driven tool</p> <p>Radial MTSK angetriebenes Werkzeug</p>		MSL010.2.00.K
<p>MODULO MOTORIZZATO RADIALE MAGGIORATO</p> <p>Radial reinforced driven tool</p> <p>Radial angetriebenes Werkzeug vergrößert</p>		MSL020.2.00
<p>MODULO MOTORIZZATO RADIALE 2 USCITE IN Y</p> <p>Radial single side twin head driven tool in Y</p> <p>Radial angetriebenes Werkzeug 2 Ausgänge in Y</p>		MSL080.2.00
<p>MODULO MOTORIZZATO SPECIALE RADIALE DISASSATO IN Z 376mm</p> <p>Radial special driven tool re-directed in z by 376mm</p> <p>Radial spezial angetriebenes Werkzeug achsversetzt in z um 376mm</p>		MSL125.2.10
<p>MODULO MOTORIZZATO SPECIALE RADIALE IN Y</p> <p>Radial special driven tool in Y</p> <p>Radial spezial angetriebenes Werkzeug in Y</p>		MSL130.2.00
<p>MODULO MOTORIZZATO ASSIALE H=55mm</p> <p>Axial driven tool H=55mm</p> <p>Axial angetriebenes Werkzeug H=55mm</p>		MSL150.2.10
<p>MODULO MOTORIZZATO ASSIALE MTSK H=55mm</p> <p>Axial MTSK driven tool H=55mm</p> <p>Axial MTSK angetriebenes Werkzeug H=55mm</p>		MSL150.2.10.K
<p>MODULO MOTORIZZATO ASSIALE PER CONTROMANDRINO H=55mm</p> <p>Axial driven tool for subspindle H=55mm</p> <p>Axial angetriebenes Werkzeug fuer Gegenspindel H=55mm</p>		MSL155.2.10
<p>MODULO MOTORIZZATO ASSIALE MAGGIORATO H=55mm</p> <p>Axial reinforced driven tool H=55mm</p> <p>Axial angetriebenes Werkzeug vergrößert H=55mm</p>		MSL170.2.10
<p>MODULO MOTORIZZATO ASSIALE BISPORGENTE</p> <p>Axial opposite face twin driven tool</p> <p>Axial angetriebenes Werkzeug halb vorspringend</p>		MSL240.2.10
<p>MODULO MOTORIZZATO ASSIALE 2 USCITE IN Y</p> <p>Axial single side twin head driven tool in Y</p> <p>Axial angetriebenes Werkzeug 2 Ausgänge in Y</p>		MSL260.2.10

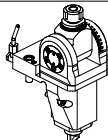
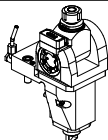
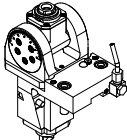
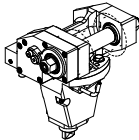
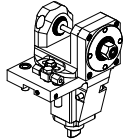
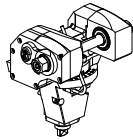
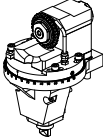
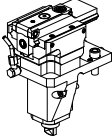
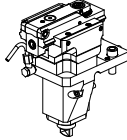
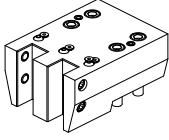
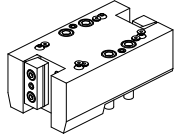
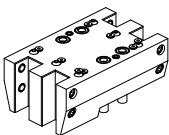
		PAGINA Page Seite
<p>MODULO MOTORIZZATO ORIENTABILE $\pm 90^\circ$ $\pm 90^\circ$ adjustable angle driven tool Angetriebenes Werkzeug schwenkbar $\pm 90^\circ$</p>		MSL333.2.00
<p>MODULO MOTORIZZATO ORIENTABILE $\pm 90^\circ$ CON NONIO DIGITALE $\pm 90^\circ$ adjustable angle driven tool with digital display Angetriebenes Werkzeug schwenkbar $\pm 90^\circ$ mit digital display</p>		MSL333.2.01
<p>MODULO MOTORIZZATO ORIENTABILE $\pm 90^\circ$ $\pm 90^\circ$ adjustable angle driven tool Angetriebenes Werkzeug schwenkbar $\pm 90^\circ$</p>		MSL335.2.00
<p>MODULO MOTORIZZATO PORTACREATORE Driven gear hobber Angetriebenes Zahnradwaelzfraes-Werkzeug</p>		MSL340.2.00
<p>MODULO MOTORIZZATO PORTACREATORE RADIALE Radial driven gear hobber Radial angetriebenes Waelzfraes-Werkzeug</p>		MSL340.2.30
<p>MODULO MOTORIZZATO PORTACREATORE MAGGIORATO Reinforced driven gear hobber Angetriebenes Zahnradwaelzfraes-Werkzeug vergroessert</p>		MSL340.2.60
<p>MODULO MOTORIZZATO PER VITI SENZA FINE Driven tool for worm screws Angetriebenes werkzeug für schrauben ohne ende</p>		MSL359.2.00
<p>MODULO MOTORIZZATO STOZZATORE CORSA 50mm H=80mm Slotting driven tool 50mm stroke H=80mm Keilnutenstossmaschine 50mm Hub H=80mm</p>		MSL360.2.00
<p>MODULO MOTORIZZATO STOZZATORE CORSA 25mm H=80mm Slotting driven tool 25mm stroke H=80mm Keilnutenstossmaschine 25mm Hub H=80mm</p>		MSL360.2.01
<p>PORTAUTENSILE RADIALE SOVRAPPOSTO QD=25mm Radial single side twin static tool QD=25mm Radial Werkzeughalter ueberlagert QD=25mm</p>		MSL440.2.00
<p>PORTAUTENSILE RADIALE DOPPIO QD=25mm Radial double static tool QD=25mm Radial Doppel-Werkzeughalter QD=25mm</p>		MSL453.2.00
<p>PORTAUTENSILE RADIALE DOPPIO SOVRAPPOSTO QD=25mm Radial double side twin static tool QD=25mm Radial Doppel-Werkzeughalter ueberlagert QD=25mm</p>		MSL460.2.00

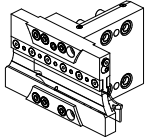
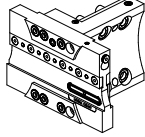
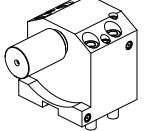
		PAGINA Page Seite
<p>PORTAUTENSILE PER LAMA DOPPIO Radial double blade holder Radial Doppel-Abstechhalter</p>		MSL520.2.00
<p>PORTAUTENSILE PER LAMA DOPPIO CON LUBRIFICAZIONE INTERNA Radial double blade holder with internal coolant Radial Doppel-Abstechhalter mit Innenkuehlung</p>		MSL520.2.04
<p>CONTROPUNTA PER CONTROMANDRINO Tailstock for subspindle Gegenspintz fuer Gegenspindel</p>		MSL950.2.00

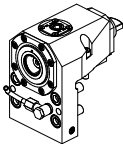
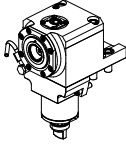
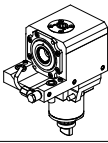
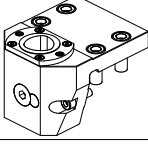
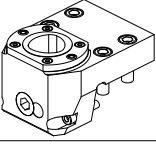
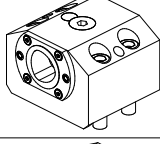
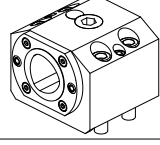
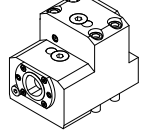
		PAGINA Page Seite
<p>MODULO MOTORIZZATO RADIALE MT CAPTO Radial driven tool MT CAPTO Radial angetriebenes Werkzeug MT CAPTO</p>		MSL010.B.40
<p>MODULO MOTORIZZATO ASSIALE MT CAPTO Axial driven tool MT CAPTO Axial angetriebenes Werkzeug MT CAPTO</p>		MSL150.B.40
<p>MODULO MOTORIZZATO ASSIALE PER CONTROMANDRINO MT CAPTO Axial driven tool for subspindle MT CAPTO Axial angetriebenes Werkzeug fuer Gegenspindel MT CAPTO</p>		MSL155.B.40
<p>PORTAUTENSILE RADIALE SINGOLO ARRETRATO MT CAPTO Radial single rear-set static tool MT CAPTO Radial Single-Werkzeughalter zurueckversetzt MT CAPTO</p>		MSL430.B.40
<p>PORTAUTENSILE RADIALE SINGOLO ARRETRATO MT CAPTO Radial single rear-set static tool MT CAPTO Radial Single-Werkzeughalter zurueckversetzt MT CAPTO</p>		MSL430.B.50
<p>PORTAUTENSILE ASSIALE SINGOLO MT CAPTO Axial single static tool MT CAPTO Axial Single-Werkzeughalter MT CAPTO</p>		MSL550.B.40
<p>PORTAUTENSILE ASSIALE SINGOLO MT CAPTO Axial single static tool MT CAPTO Axial Single-Werkzeughalter MT CAPTO</p>		MSL550.B.50
<p>PORTAUTENSILE ASSIALE BISPORGENTE MT CAPTO Axial opposite face twin static tool MT CAPTO Axial Halter halb vorspringend mit MT CAPTO</p>		MSL570.B.40

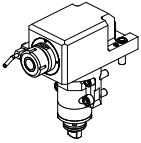
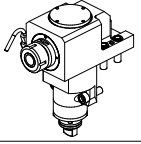
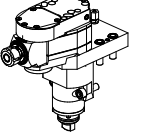
		PAGINA Page Seite
<p>MODULO MOTORIZZATO ASSIALE Axial driven tool Axial angetriebenes Werkzeug</p>		MSL150.3.10
<p>MODULO MOTORIZZATO ASSIALE RIDOTTO I=2:1 Axial geared-down I=2:1 driven tool Axial angetriebenes Werkzeug untersetzt I=2:1</p>		MSL190.3.10
<p>MODULO MOTORIZZATO INCLINEVOLE $\pm 15^\circ$ IN Y $\pm 15^\circ$ Y axis adjustable angle driven tool Angetriebenes Werkzeug kipbar $\pm 15^\circ$ in Y</p>		MSL358.3.00

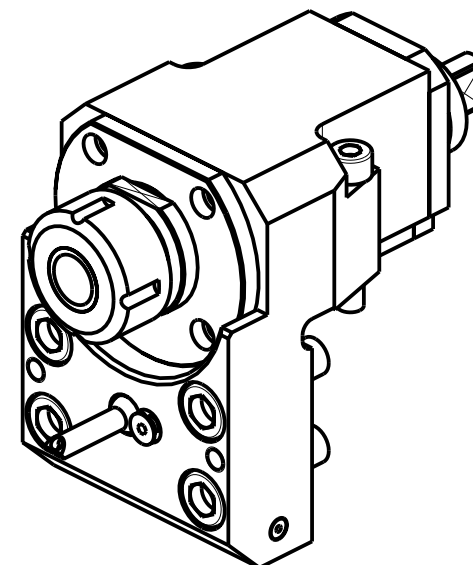
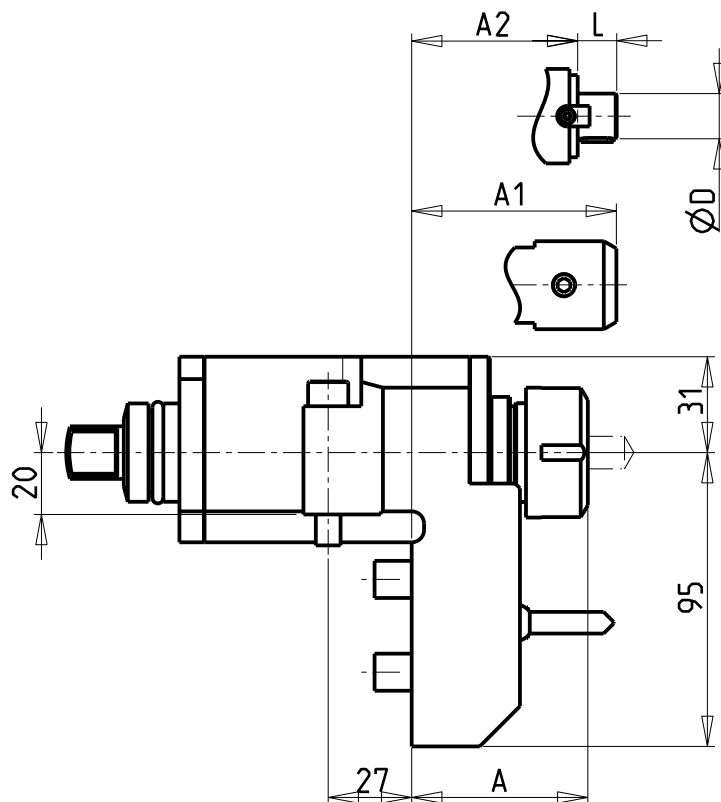
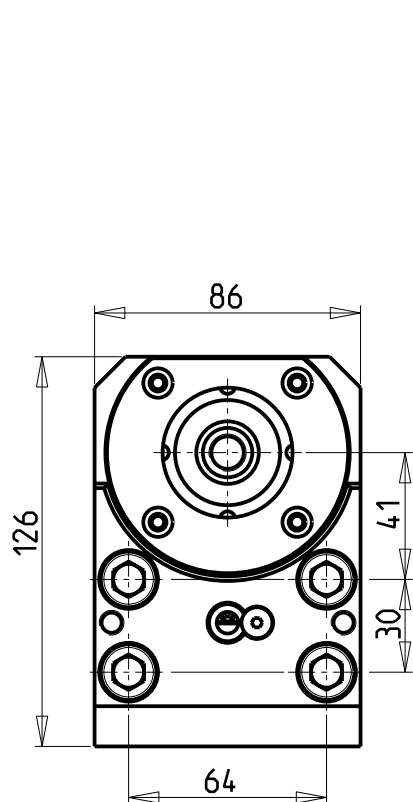

- Chiave inclusa
- Key included
- Schlusssel inbegriffen

Cod. MT	Cod. MORI-SEIKI	Mandrino Spindle Spindel	I	RPM	Coppia Max Max Torque Max Drehmoment	Lubrificazione int. Coolant through Innenkuehlung	Lubrificazione est. Ext. coolant Aussenkuehlung	A	A1	A2	D	L	CHIAVI NON INCLUDE Keys not included Schlusssel nicht einbegriffen	
M0020225	T32107B05	ER25	1:1	6000	40Nm	-	X	56.96	-	-	-	-	CHUB36	CHSTER25
M0021225	-	ER25	1:1	6000	40Nm	P=30bar	-	71.46	-	-	-	-	CHUB36	CHSTER25
M0020132	-	ER32	1:1	6000	40Nm	-	X	65.96	-	-	-	-	CHUB36	CHSTER32
M0021617	-	Ø16x17	1:1	6000	40Nm	-	X	-	-	37	16	17	CHUB36	CH_VTCROCE_M08
M0020325	-	WELDON 25	1:1	6000	40Nm	-	X	-	76.8	-	-	-	-	-

DMG-MORI

SL-ZL150/153/154(MC-SMC-Y-SY) DL150MC DL15MC

MODULO MOTORIZZATO RADIALE

Radial driven tool

Radial angetriebenes Werkzeug

Subject to change without notice.

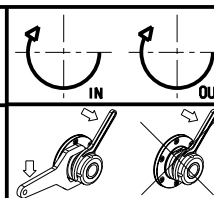

M.T. srl

Via Casino Albini 480
Tel. 0541/956034-957884
Fax 0541/956341

47842 S. GIOVANNI IN M. (RN)
e-mail: mtma@tmarchetti.com
http://www.tmmarchetti.com



PAGINA MSL010-1-00

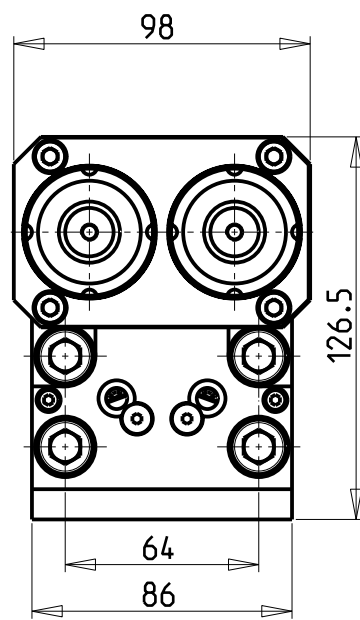
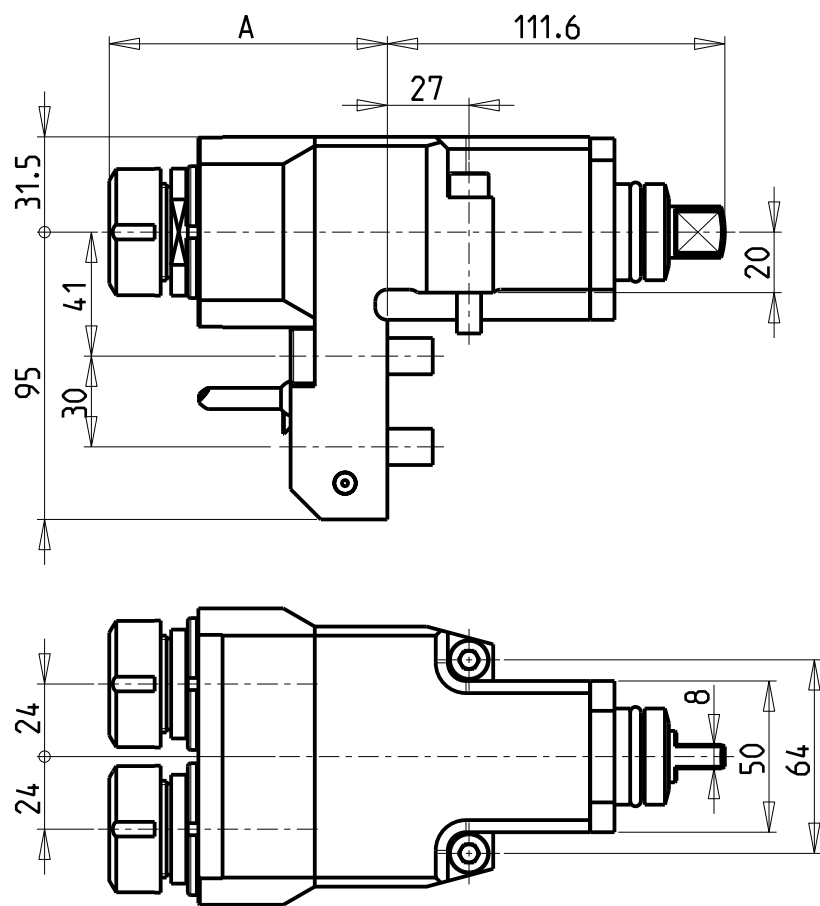

ATTENZIONE - ATTENTION - ACHTUNG

- Per lo smontaggio degli utensili utilizzare sempre la chiave di contrasto come indicato nel manuale d'uso.
- For disassembly of the tools use always the contrast key as mentioned in the user instructions.
- Fuer das Abmontieren der Werkzeuge immer den Gegenschlüssel benutzen wie in der Bedienungsanleitung erwaeht.

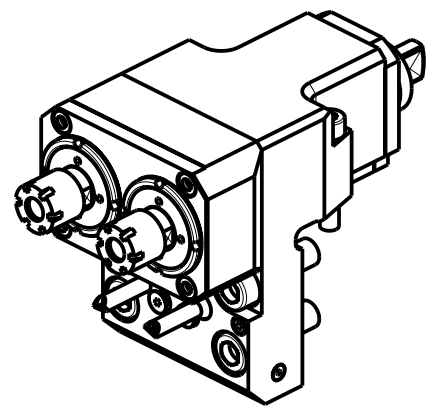

MSL0020216

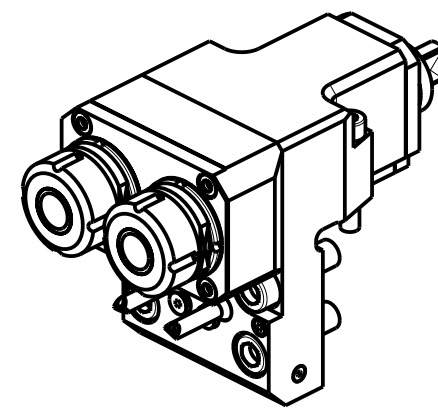

MSL0020225

Cod. MT	Mandrino Spindel	I	RPM	Coppia Max Max Torque Max Drehmoment	Lubrificazione est. Ext. coolant Aussenkuehlung	A	CHIAVI NON INCLUDE Keys not included Schluesssel nicht einbegriffen	
							CHUB	CHMNER
MSL0020216	ER16	1:1	6000	30Nm	X	91.5	CHUB17	CHMNER16
MSL0020225	ER25	1:1	6000	30Nm	X	91.96	CHUB36	CHSTER25

DMG-MORI
SL-ZL150/153/154(MC-SMC-Y-SY) DL150MC DL15MC

MODULO MOTORIZZATO RADIALE 2 USCITE IN Y
Radial single side twin head driven tool in Y
Radial angetriebenes Werkzeug 2 Ausgaenge in Y

Subject to change without notice.

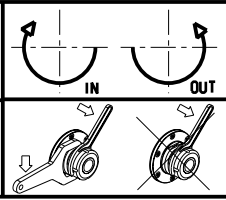

M.T. srl
Via Casino Albini 480
Tel. 0541/956034-957884
Fax 0541/956341
47842 S. GIOVANNI IN M. (RN)
e-mail: mtma@mtmarchetti.com
http://www.mtmarchetti.com



PAGINA MSL080-1-00

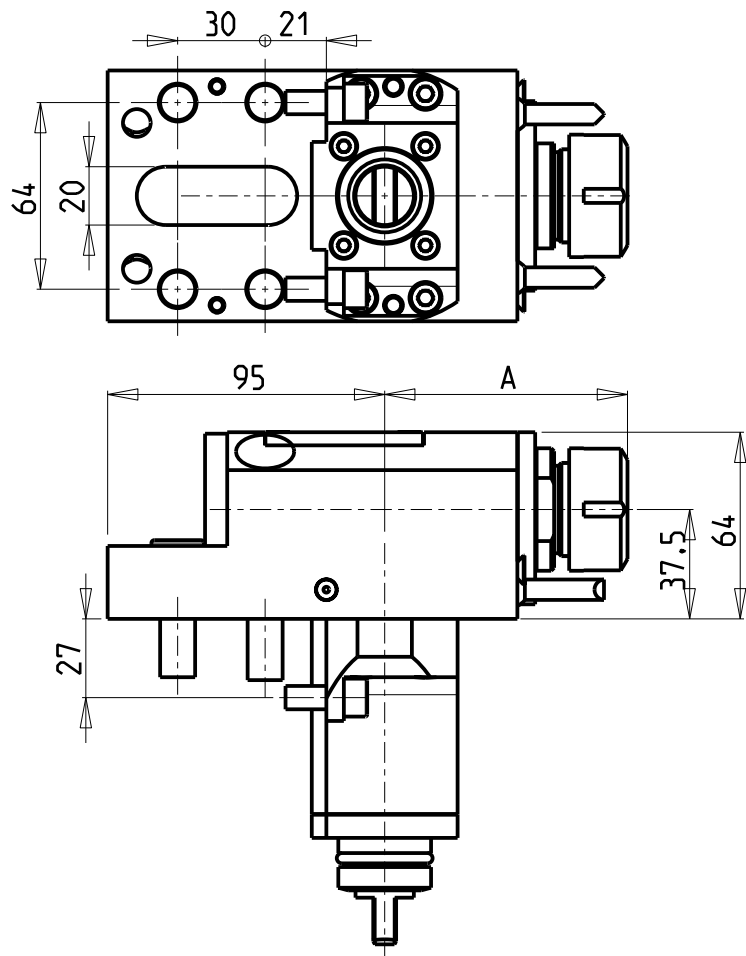

ATTENZIONE - ATTENTION - ACHTUNG

- Per lo smontaggio degli utensili utilizzare sempre la chiave di contrasto come indicato nel manuale d'uso.
- For disassembly of the tools use always the contrast key as mentioned in the user instructions.
- Fuer das Abmontieren der Werkzeuge immer den Gegenschlüssel benutzen wie in der Bedienungsanleitung erwaeht.

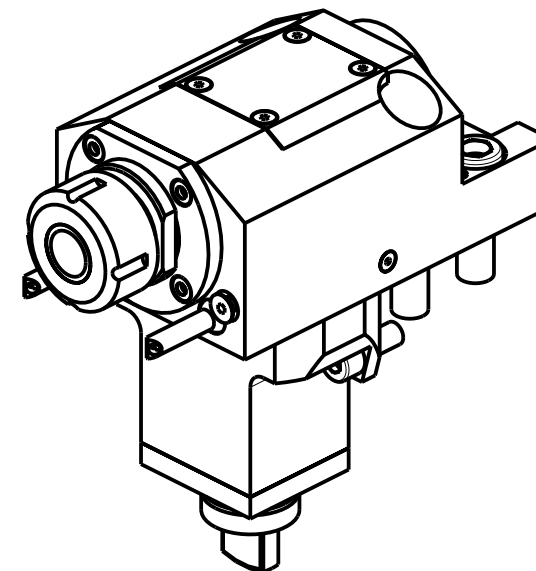

Cod. MT	Cod. MORI-SEIKI	Mandrino Spindle Spindel	I	RPM	Coppia Max Max Torque Max Drehmoment	Lubrificazione int. Coolant through Innenkuehlung	Lubrificazione est. Ext. coolant Aussenkuehlung	A	CHIAVI NON INCLUSE Keys not included Schlüssel nicht einbegriffen	
M0040425	T32108B07	ER25	1:1	6000	40Nm		X	83.26	CHUB36	CHSTER25
M0041725	-	ER25	1:1	6000	40Nm	P=70bar		83.26	CHUB36	CHSTER25

DMG-MORI

SL-ZL150/153/154(MC-SMC-Y-SY) DL150MC DL15MC

MODULO MOTORIZZATO ASSIALE

Axial driven tool

Axial angetriebenes Werkzeug

Subject to change without notice.

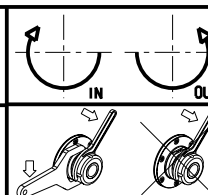

M.T. srl

Via Casino Albini 480
Tel. 0541/956034-957884
Fax 0541/956341
47842 S. GIOVANNI IN M. (RN)
e-mail: mtma@mtmarchetti.com
http://www.mtmarchetti.com



PAGINA MSL150-1-10

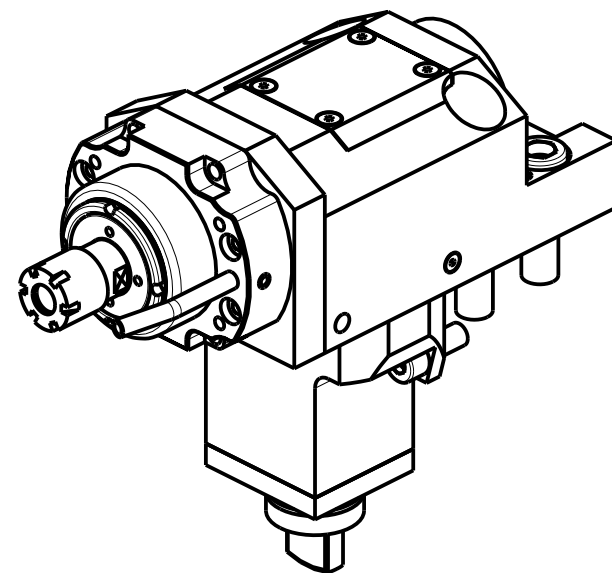
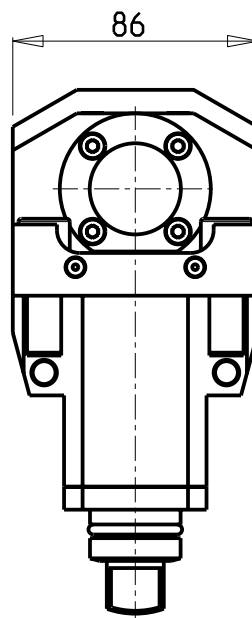
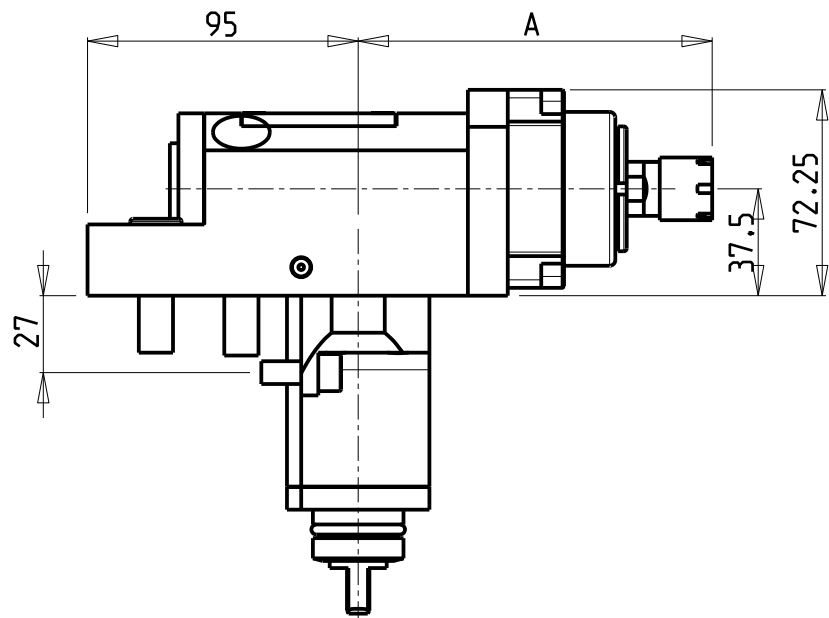
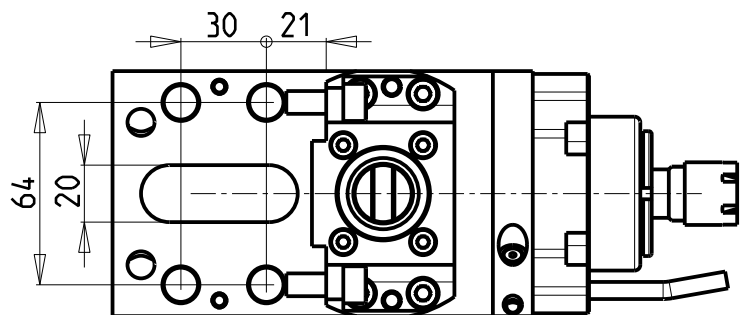

ATTENZIONE - ATTENTION - ACHTUNG

- PRIMA DI UTILIZZARE IL MOTORIZZATO CONSULTARE LE ISTRUZIONI ALLEGATE!
- BEFORE USING THE DRIVEN TOOL, PLEASE CHECK THE ENCLOSED INSTRUCTION SHEET!
- VOR DER BENUTZUNG DES ANGETRIEBENEN WERKZEUGES, DIE BEILIEGENDEN INSTRUKTIONEN DURCHLESEN!

ATTENZIONE - ATTENTION - ACHTUNG

- Per lo smontaggio degli utensili utilizzare sempre la chiave di contrasto come indicato nel manuale d'uso.
- For disassembly of the tools use always the contrast key as mentioned in the user instructions.
- Fuer das Abmontieren der Werkzeuge immer den Gegenschlüssel benutzen wie in der Bedienungsanleitung erwaeht.

Cod. MT	Mandrino Spindle Spindel	I	RPM	Coppia Max Max Torque Max Drehmoment	Lubrificazione est. Ext. coolant Aussenkuehlung	A	CHIAVI INCLUSE Keys included Schluessel einbegriffen
M0050016	ER16	1:5.625	22500	6Nm	X	124.25	CHUB17 CHMNER16

DMG-MORI
SL-ZL150/153/154(MC-SMC-Y-SY) DL150MC DL15MC

MODULO MOTORIZZATO ASSIALE MOLTIPLICATO I=1:5.625
Axial geared-up I=1:5.625 driven tool
Axial angetriebenes Werkzeug uebersetzt I=1:5.625

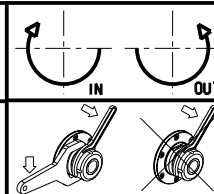

M.T. srl
Via Casino Albini 480
Tel. 0541/956034-957884
Fax 0541/956341
47842 S. GIOVANNI IN M. (RN)
e-mail: mtma@mtmarchetti.com
http://www.mtmarchetti.com



PAGINA MSL210-1-10

Subject to change without notice.

10/2021

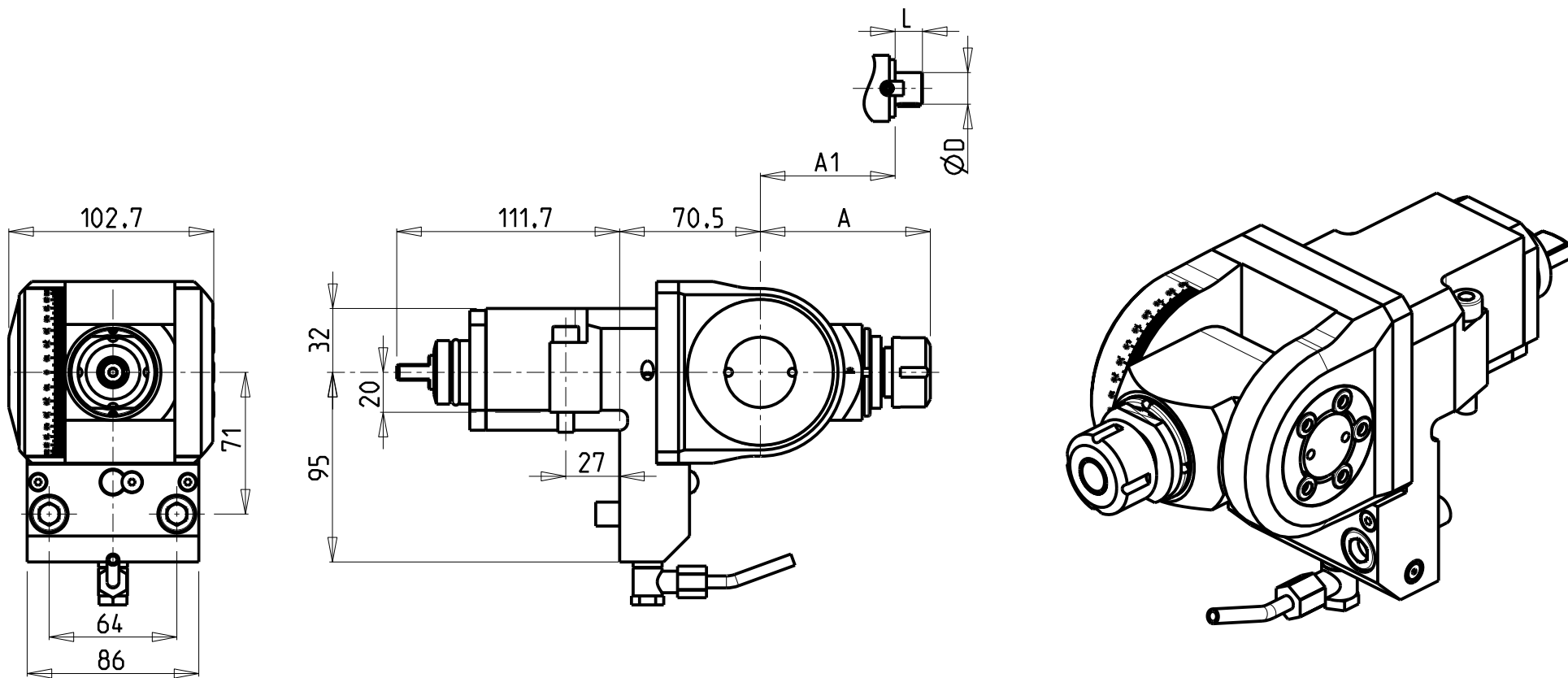

Cod. MT	Mandrino Spindle Spindel	I	RPM	Coppia Max Max Torque Max Drehmoment	Lubrificazione est. Ext. coolant Aussenkuehlung	A	A1	D	L	CHIAVI INCLUSE Keys included Schluessel inbegriffen	
MSL0240120	ER20	1:1	6000	40Nm	X	85.16	-	-	-	CHUB36	CHSTER20
MSL0240125	ER25	1:1	6000	40Nm	X	86.16	-	-	-	CHUB36	CHSTER25
MSL0240516	Ø16x17	1:1	6000	40Nm	X	-	65	16	17	CHUB36	CH_VTCROCE_M08
MSL0240522	Ø22x19	1:1	6000	40Nm	X	-	66	22	19	CHUB36	CH_VTCROCE_M10
MSL0240519	Ø3/4"x3/4"	1:1	6000	40Nm	X	-	65	3/4"	3/4"	CHUB36	CH_VTCROCE_M08

DMG-MORI

SL-ZL150/153/154(MC-SMC-Y-SY) DL150MC DL15MC

MODULO MOTORIZZATO ORIENTABILE ±90°

±90° adjustable angle driven tool

Angetriebenes Werkzeug schwenkbar ±90°

Subject to change without notice.

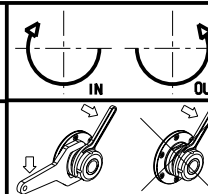

M.T. srl

Via Casino Albini 480
Tel. 0541/956034-957884
Fax 0541/956341

47842 S. GIOVANNI IN M. (RN)
e-mail: mtma@mtmarchetti.com
http://www.mtmarchetti.com



PAGINA MSL333-1-00

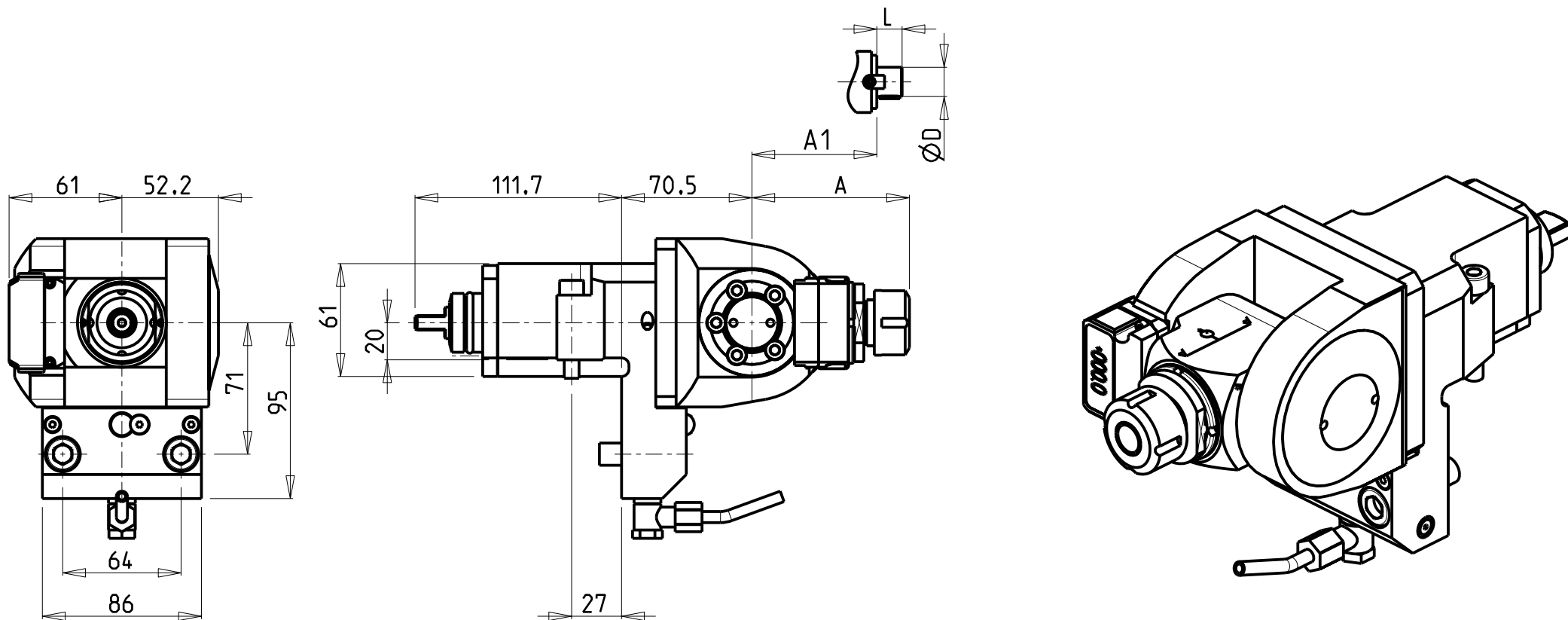

Cod. MT	Mandrino Spindle Spindel	I	RPM	Coppia Max Max Torque Max Drehmoment	Lubrificazione est. Ext. coolant Aussenkuehlung	A	A1	D	L	CHIAVI INCLUSE Keys included Schluessel inbegriffen	
MSL0200120	ER20	1:1	6000	40Nm	X	85.16	-	-	-	CHUB36	CHSTER20
MSL0200125	ER25	1:1	6000	40Nm	X	86.16	-	-	-	CHUB36	CHSTER25
MSL0200516	Ø16x17	1:1	6000	40Nm	X	-	65	16	17	CHUB36	CH_VTCROCE_M08
MSL0200522	Ø22x19	1:1	6000	40Nm	X	-	66	22	19	CHUB36	CH_VTCROCE_M10
MSL0200519	Ø3/4"x3/4"	1:1	6000	40Nm	X	-	65	3/4"	3/4"	CHUB36	CH_VTCROCE_M08

DMG-MORI
SL-ZL150/153/154(MC-SMC-Y-SY) DL150MC DL15MC

MODULO MOTORIZZATO ORIENTABILE ±90° CON NONIO DIGITALE
±90° adjustable angle driven tool with digital display
Angetriebenes Werkzeug schwenkbar ±90° mit digital display

Subject to change without notice.

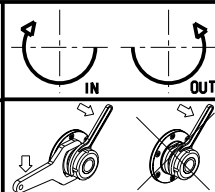

M.T. srl
Via Casino Albini 480
Tel. 0541/956034-957884
Fax 0541/956341
47842 S. GIOVANNI IN M. (RN)
e-mail: mtma@tmarchetti.com
http://www.tmmarchetti.com



PAGINA MSL333-1-01

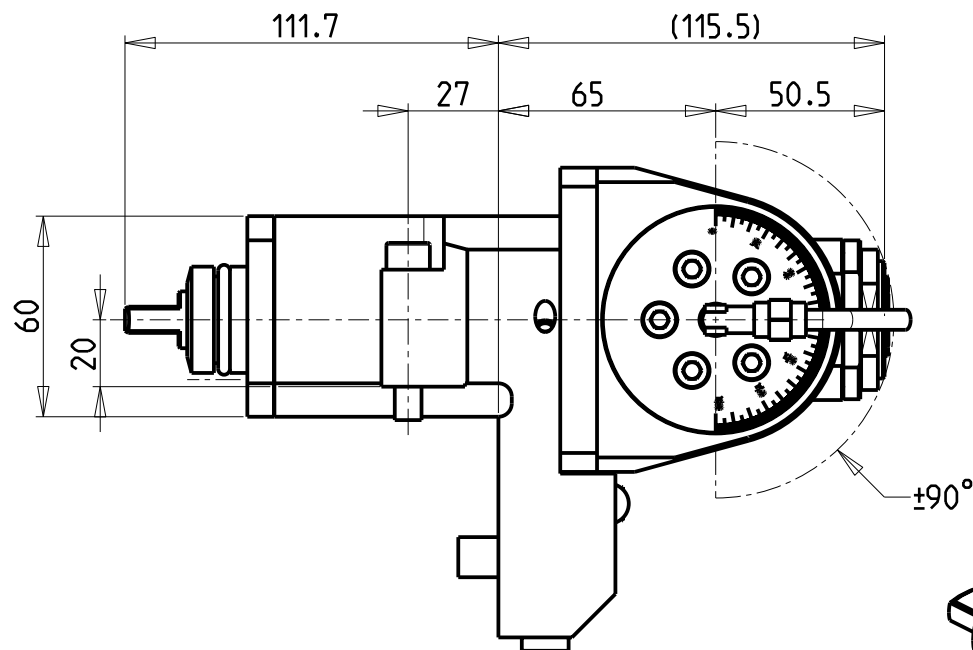
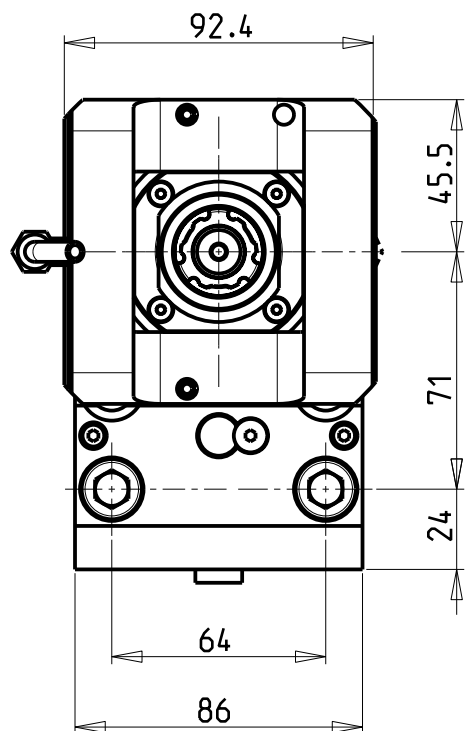

ATTENZIONE - ATTENTION - ACHTUNG

- Per lo smontaggio degli utensili utilizzare sempre la chiave di contrasto come indicato nel manuale d'uso.
- For disassembly of the tools use always the contrast key as mentioned in the user instructions.
- Fuer das Abmontieren der Werkzeuge immer den Gegenschuessel benutzen wie in der Bedienungsanleitung erwaeht.

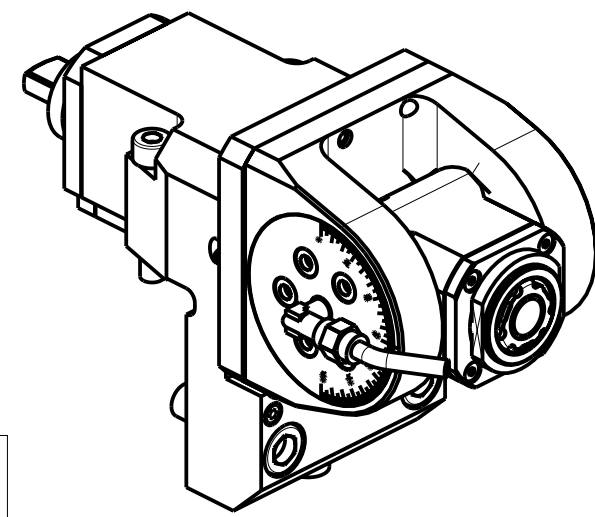

Non utilizzabile sulla torretta sinistra dei modelli DL15 e DL151 in quanto fuori volteggio
 Do not use on left turret of models DL15 and DL151. Out of max. dimensions of rotation!
 Nicht auf linken Revolver der Modelle DL15 und DL 151 benutzen. Sie befindet sich ausser Raumbedarf bei Drehung!

Cod. MT	Mandrino Spindle Spindel	I	RPM	Coppia Max Max Torque Max Drehmoment	Lubrificazione int. Coolant through Innenkuehlung	Lubrificazione est. Ext. coolant Aussenkuehlung	CHIAVI INCLUDE Keys included Schluessel inbegriffen		
MSL0110120	ER A 20	1:1	6000	30Nm		X	CHUB36	CHUB22	CHTAER20ZC
MSL0110220	ER A 20	1:1	6000	30Nm	P=70bar	X	CHUB36	CHUB22	CHTAER20ZC

DMG-MORI
 MOD: SL-ZL150/153/154(MC-SMC-Y-SY) DL150MC DL15MC

MODULO MOTORIZZATO ORIENTABILE +/-90°
 +/-90° adjustable angle driven tool
 Angetriebenes Werkzeug schwenkbar +/-90°

Subject to change without notice.

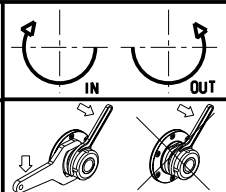

M.T. srl
 Via Casino Albini 480
 Tel. 0541/956034-957884
 Fax 0541/956341
 47842 S. GIOVANNI IN M. (RN)
 e-mail: mtma@mtmarchetti.com
 http://www.mtmarchetti.com



PAGINA MSL335-1-00

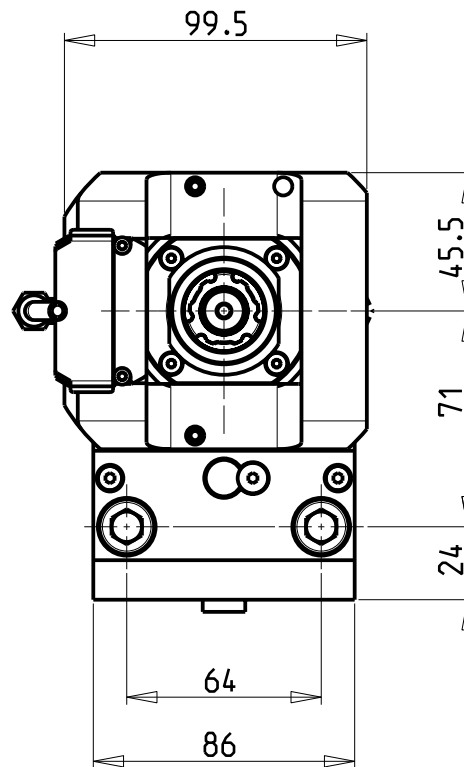
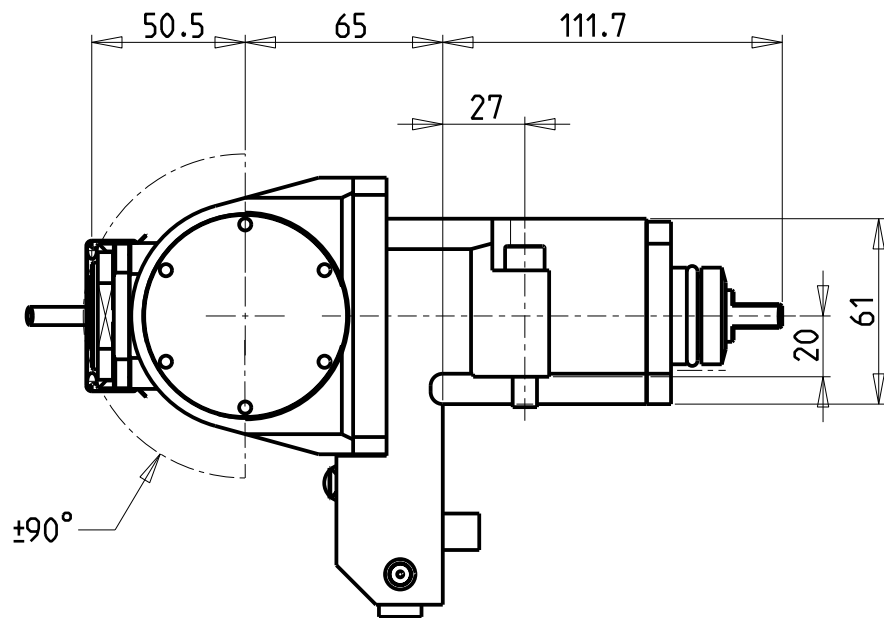

ATTENZIONE - ATTENTION - ACHTUNG

- Per lo smontaggio degli utensili utilizzare sempre la chiave di contrasto come indicato nel manuale d'uso.
- For disassembly of the tools use always the contrast key as mentioned in the user instructions.
- Fuer das Abmontieren der Werkzeuge immer den Gegenschlüssel benutzen wie in der Bedienungsanleitung erwäehnt.

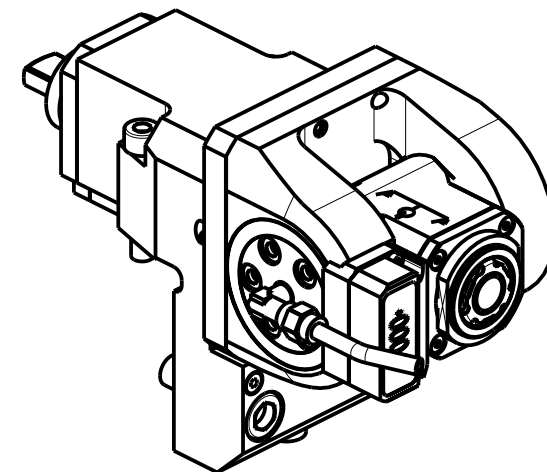

Non utilizzabile sulla torretta sinistra dei modelli DL15 e DL151 in quanto fuori voltaggio
 Do not use on left turret of models DL15 and DL151. Out of max. dimensions of rotation!
 Nicht auf linken Revolver der Modelle DL15 und DL 151 benutzen. Sie befindet sich ausser Raumbedarf bei Drehung!

Cod. MT	Mandrino Spindle Spindel	I	RPM	Coppia Max Max Torque Max Drehmoment	Lubrificazione int. Coolant through Innenkuehlung	Lubrificazione est. Ext. coolant Aussekuehlung	CHIAVI INCLUDE Keys included Schluessel inbegriffen		
							CHUB36	CHUB22	CHTAER20ZC
MSL0115120	ER A 20	1:1	6000	30Nm	-	X	CHUB36	CHUB22	CHTAER20ZC
MSL0115220	ER A 20	1:1	6000	30Nm	P=70bar	X	CHUB36	CHUB22	CHTAER20ZC

DMG-MORI

MOD: SL-ZL150/153/154(MC-SMC-Y-SY) DL150MC DL15MC

MODULO MOTORIZZATO ORIENTABILE ±90° CON NONIO DIGITALE

±90° adjustable angle driven tool with digital display

Angetriebenes Werkzeug schwenkbar ±90° mit digital display

Subject to change without notice.

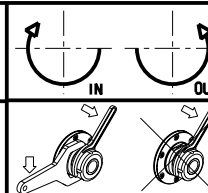

M.T. srl

Via Casino Albini 480
 Tel. 0541/956034-957884
 Fax 0541/956341
 47842 S. GIOVANNI IN M. (RN)
 e-mail: mtma@mtmarchetti.com
 http://www.mtmarchetti.com



PAGINA MSL335-1-01

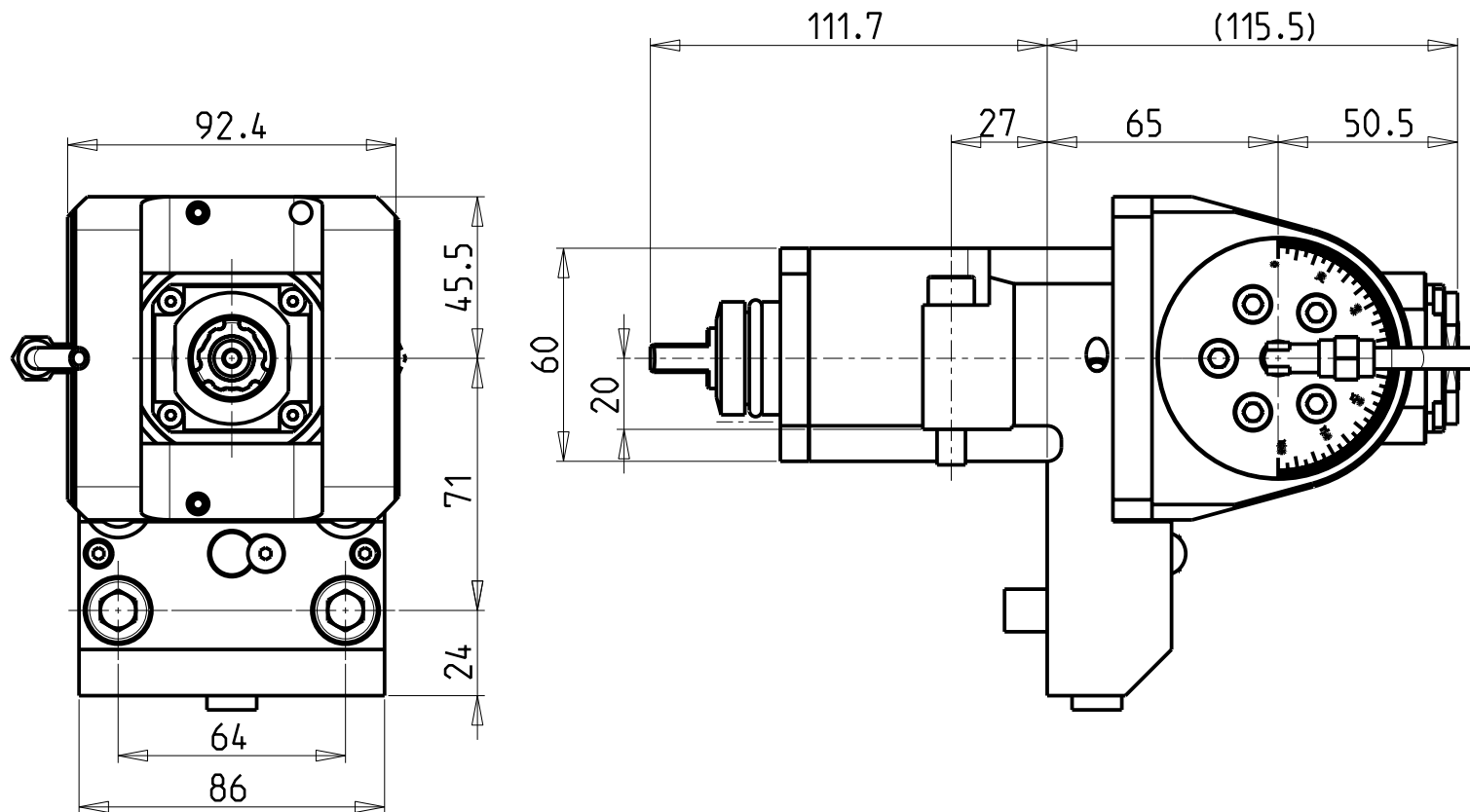

ATTENZIONE - ATTENTION - ACHTUNG

- Per lo smontaggio degli utensili utilizzare sempre la chiave di contrasto come indicato nel manuale d'uso.
- For disassembly of the tools use always the contrast key as mentioned in the user instructions.
- Fuer das Abmontieren der Werkzeuge immer den Gegenschlüssel benutzen wie in der Bedienungsanleitung erwäehnt.

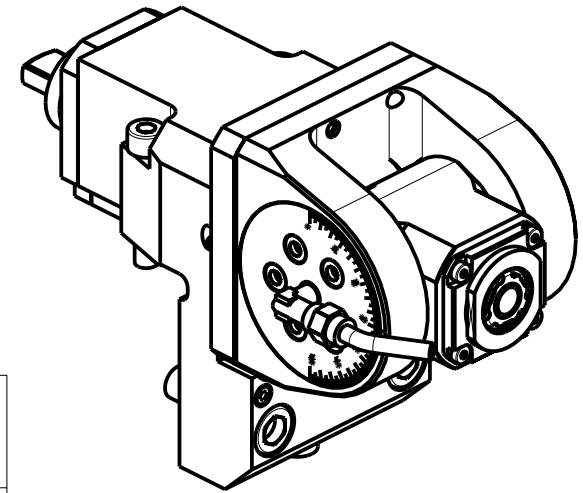

Non utilizzabile sulla torretta sinistra dei modelli DL15 e DL151 in quanto fuori volteggio
 Do not use on left turret of models DL15 and DL151. Out of max. dimensions of rotation!
 Nicht auf linken Revolver der Modelle DL15 und DL 151 benutzen. Sie befindet sich ausser Raumbedarf bei Drehung!

Cod. MT	Mandrino Spindle Spindel	I	RPM	Coppia Max Max Torque Max Drehmoment	Lubrificazione int. Coolant through Innenkuehlung	Lubrificazione est. Ext. coolant Aussenkuehlung	CHIAVI INCLUSE Keys included Schluesssel inbegriffen		
MSL0110316	ERA16	1:2	12000	8Nm		X	CHUB19_SP3	CHUB32	CHTAER16ZC
MSL0110416	ERA16	1:2	12000	8Nm	P=70bar	X	CHUB19_SP3	CHUB32	CHTAER16ZC

DMG-MORI
 SL-ZL150/153/154(MC-SMC-Y-SY) DL150MC DL15MC

MODULO MOTORIZZATO ORIENTABILE +/-90° MOLTIPLICATO I=1:2
 +/-90° adjustable angle driven tool geared-up I=1:2
 Angetriebenes Werkzeug schwenkbar +/-90° uebersetzt I=1:2

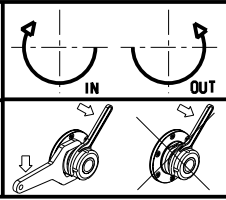

M.T. srl
 Via Casino Albini 480
 Tel. 0541/956034-957884
 Fax 0541/956341
 47842 S. GIOVANNI IN M. (RN)
 e-mail: mtma@mtmarchetti.com
 http://www.mtmarchetti.com



PAGINA MSL336-1-00

Subject to change without notice.

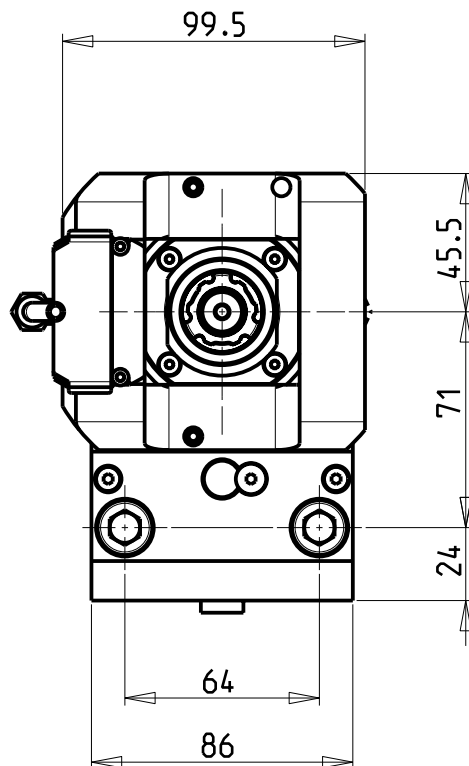
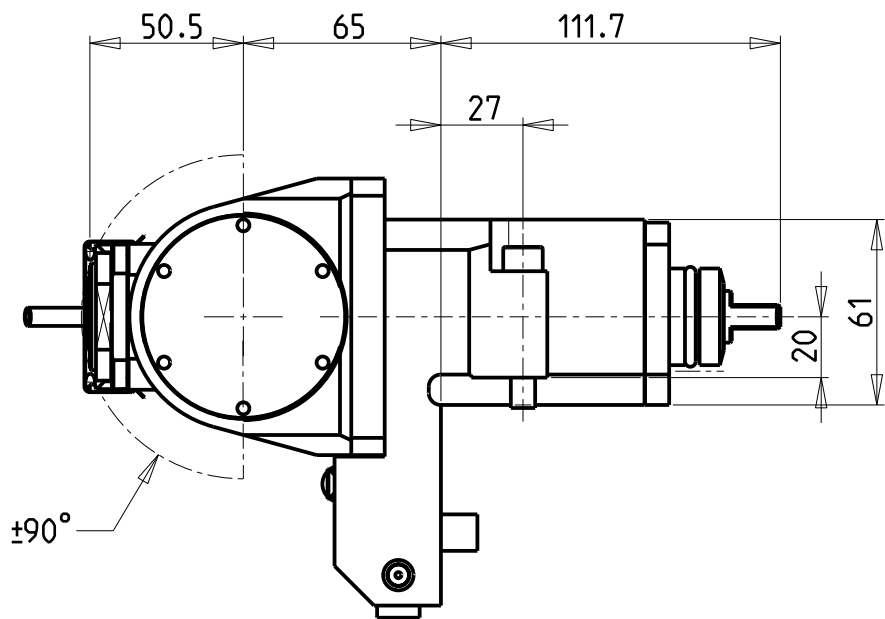

ATTENZIONE - ATTENTION - ACHTUNG

- Per lo smontaggio degli utensili utilizzare sempre la chiave di contrasto come indicato nel manuale d'uso.
- For disassembly of the tools use always the contrast key as mentioned in the user instructions.
- Fuer das Abmontieren der Werkzeuge immer den Gegenschlüssel benutzen wie in der Bedienungsanleitung erwäehnt.

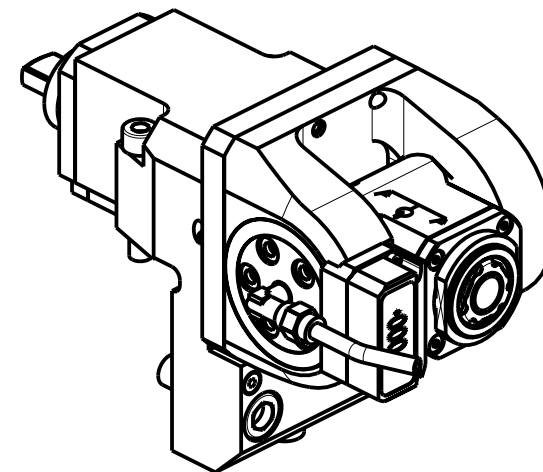

Non utilizzabile sulla torretta sinistra dei modelli DL15 e DL151 in quanto fuori volteggio
 Do not use on left turret of models DL15 and DL151. Out of max. dimensions of rotation!
 Nicht auf linken Revolver der Modelle DL15 und DL 151 benutzen. Sie befindet sich ausser Raumbedarf bei Drehung!

Cod. MT	Mandrino Spindle Spindel	I	RPM	Coppia Max Max Torque Max Drehmoment	Lubrificazione int. Coolant through Innenkuehlung	Lubrificazione est. Ext. coolant Aussenkuehlung	CHIAVI INCLUSE Keys included Schluessel inbegriffen		
MSL0115316	ERA16	1:2	12000	8Nm	-	X	CHUB19_SP3	CHUB32	CHTAER16ZC
MSL0115416	ERA16	1:2	12000	8Nm	P=70bar	X	CHUB19_SP3	CHUB32	CHTAER16ZC

DMG-MORI

SL-ZL150/153/154(MC-SMC-Y-SY) DL150MC DL15MC

MODULO MOTORIZZATO ORIENTABILE +/-90° MOLTIPLICATO I=1:2 CON NONIO DIGITALE

+/-90° adjustable angle driven tool geared-up I=1:2 with digital display

Angetriebenes Werkzeug schwenkbar +/-90° uebersetzt I=1:2 mit digital display

Subject to change without notice.

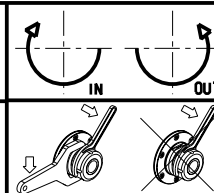

M.T. srl

Via Casino Albini 480
 Tel. 0541/956034-957884
 Fax 0541/956341

47842 S. GIOVANNI IN M. (RN)
 e-mail: mtma@mtmarchetti.com
 http://www.mtmarchetti.com



PAGINA MSL336-1-01

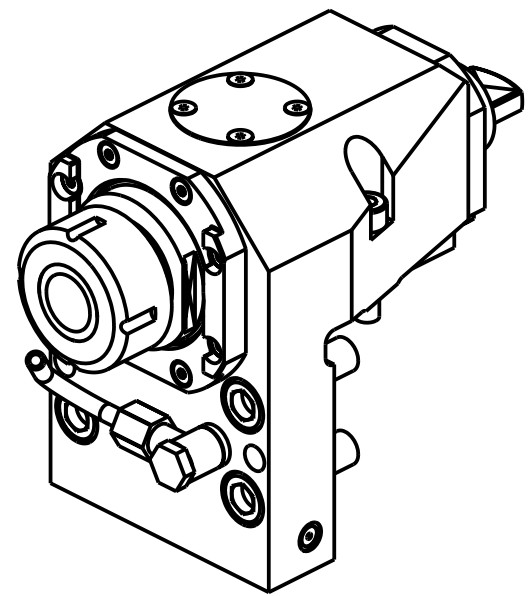
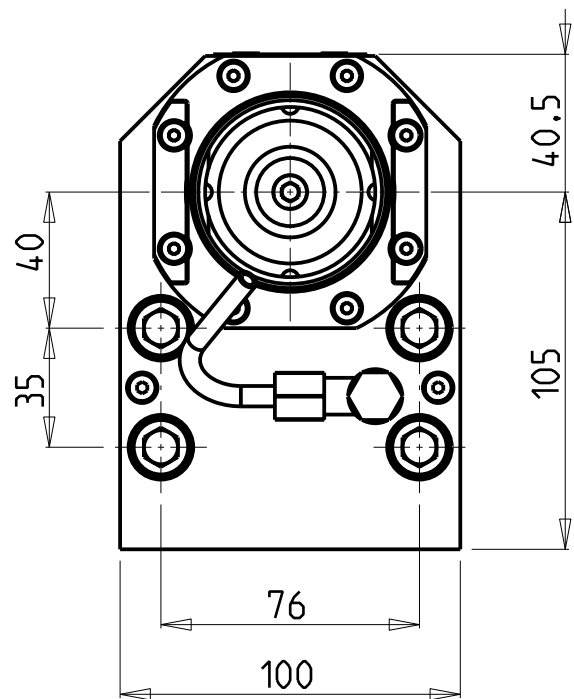
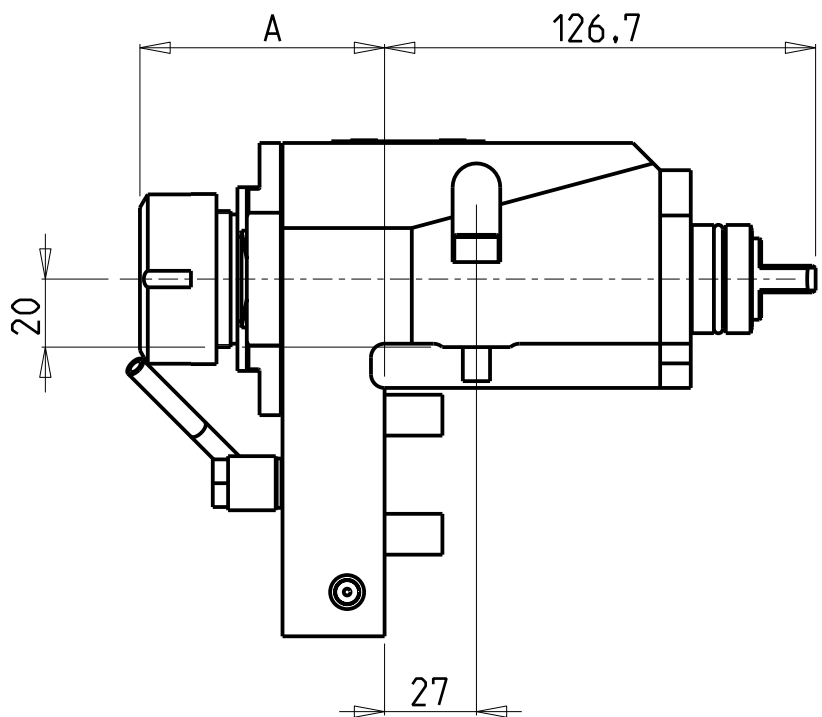

Cod. MT	Mandrino Spindle Spindel	I	RPM	Coppia Max Max Torque Max Drehmoment	Lubrificazione int. Coolant through Innenkuehlung	Lubrificazione est. Ext. coolant Aussenkuehlung	A	CHIAVI NON INCLUSE Keys not included Schlüssel nicht einbegriffen		
MSL0150432	ERA32	1:1	6000	70Nm	P=70bar	X	56.25	CHUB30	MNZ0410005	CHTAER32ZC
MSL0150132	ER32	1:1	6000	70Nm	-	X	71.91	-	MNZ0410005	CHSTER32
MSL0150232	ER32	1:1	6000	70Nm	P=70bar	X	74.91	-	MNZ0410005	CHSTER32

- Chiave inclusa
- Key included
- Schlüssel einbegriffen

DMG-MORI
 MOD: SL-ZL200/203/204/250/253/254(MC-SMC) SL2500Y DL-ZL200/250(MC)

MODULO MOTORIZZATO RADIALE
 Radial driven tool
 Radial angetriebenes Werkzeug

Subject to change without notice.

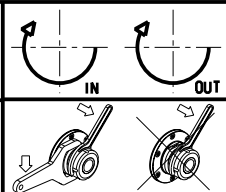

M.T. srl
 Via Casino Albini 480
 Tel. 0541/956034-957884
 Fax 0541/956341
 47842 S. GIOVANNI IN M. (RN)
 e-mail: mtma@mtmarchetti.com
 http://www.mtmarchetti.com



PAGINA MSL010-2-00

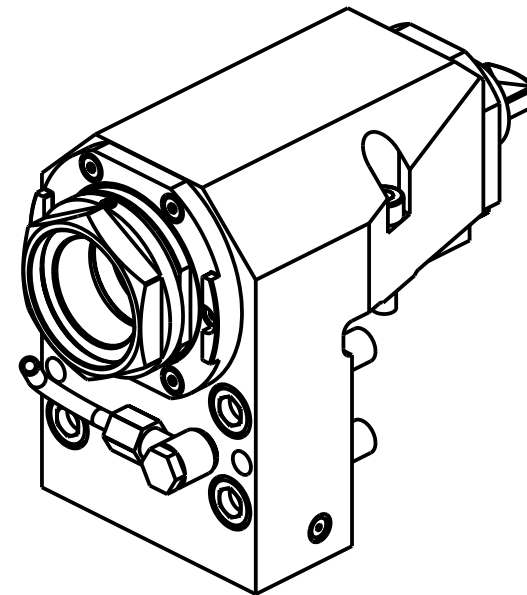
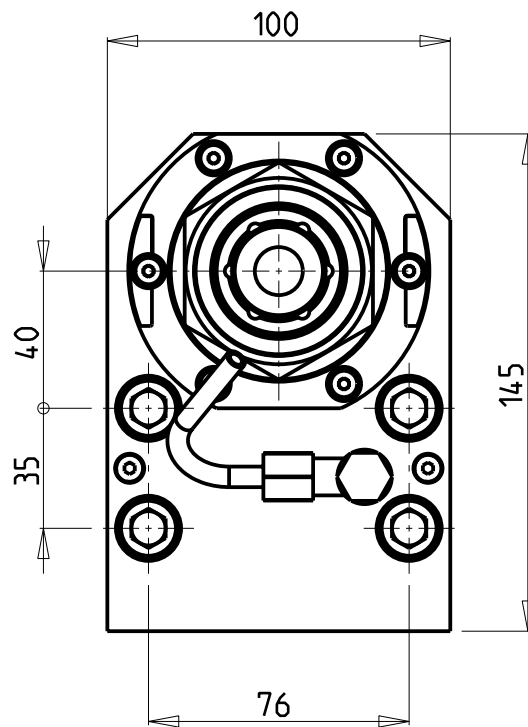
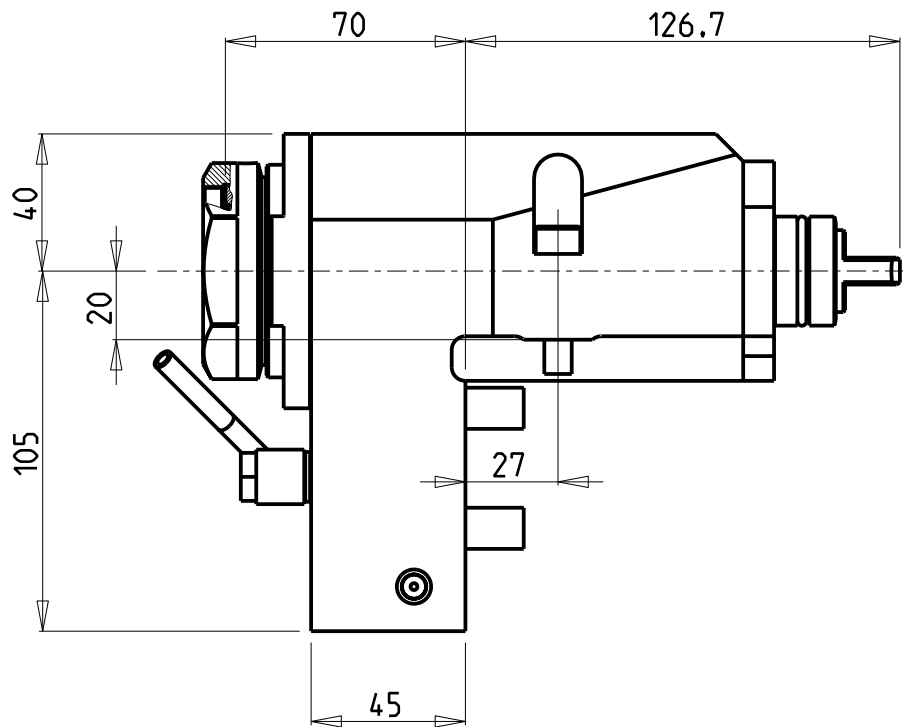

PER PORTAUTENSILI MODULARI MTSK-50 VEDI PAG. TBL300-1-50
 FOR MTSK-50 QUIK CHANGE TOOLHOLDERS CLAMPINGS SEE PAGE TBL300-1-50
 FUER MTSK-50 MODULARE WERKZEUGAUFNAHMEN SIEHE SEITE TBL300-1-50

- Chiave inclusa
- Key included
- Schluessel inbegriffen

Cod. MT	Mandrino Spindle Spindel	I	RPM	Coppia Max Max Torque Max Drehmoment	Lubrificazione est. Ext. coolant Aussenkuehlung	CHIAVI NON INCLUSE Keys not included Schluessel nicht einbegriffen	
MSL0360150	MTSK-50	1:1	6000	70Nm	X	CHUB55	OKU0430007 *

DMG-MORI
 MOD: SL-ZL200/203/204/250/253/254(MC-SMC) SL2500Y DL-ZL200/250(MC)

MODULO MOTORIZZATO RADIALE MTSK
 Radial MTSK driven tool
 Radial MTSK angetriebenes Werkzeug

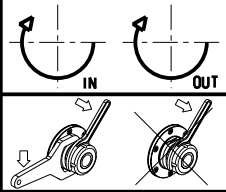

M.T. srl
 Via Casino Albini 480
 Tel. 0541/956034-957884
 Fax 0541/956341
 47842 S. GIOVANNI IN M. (RN)
 e-mail: mtma@mtmarchetti.com
 http://www.mtmarchetti.com



PAGINA MSL010-2-00-K

Subject to change without notice.

10/2021

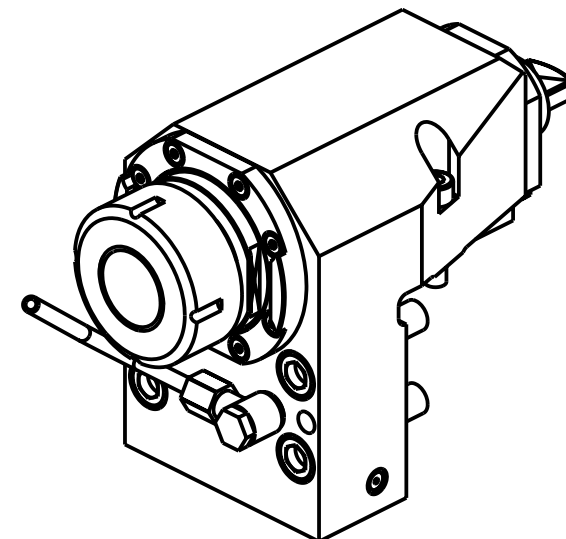
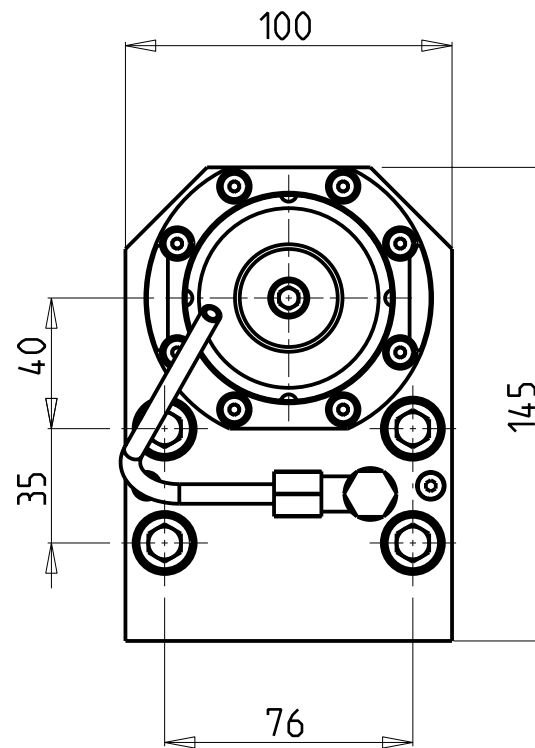
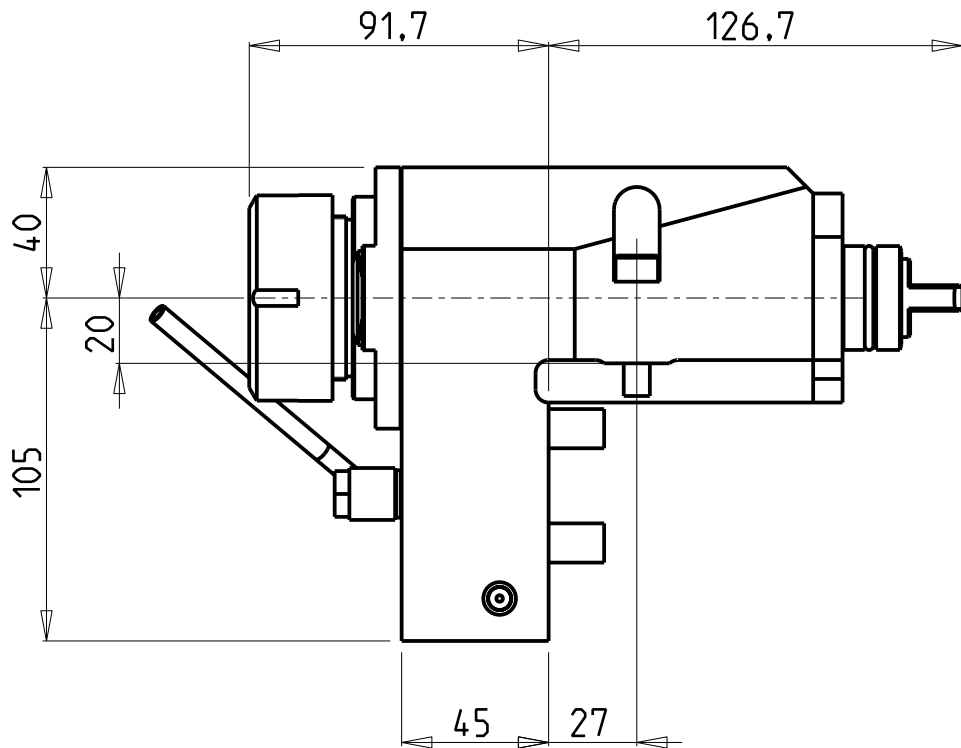

- Chiave inclusa
- Key included
- Schluessel inbegriffen

Cod. MT	Mandrino Spindle Spindel	I	RPM	Coppia Max Max Torque Max Drehmoment	Lubrificazione int. Coolant through Innenkuehlung	Lubrificazione est. Ext. coolant Aussenkuehlung	CHIAVI NON INCLUSE Keys not included Schluessel nicht einbegriffen	
							OKU0430007	CHSTER40
MSL0500140	ER40	1:1	6000	70Nm	-	X	OKU0430007	CHSTER40
MSL0500240	ER40	1:1	6000	70Nm	P=70bar	X	OKU0430007	CHSTER40

DMG-MORI
 MOD: SL-ZL200/203/204/250/253/254(MC-SMC) SL2500Y DL-ZL200/250(MC)

MODULO MOTORIZZATO RADIALE MAGGIORATO
 Radial reinforced driven tool
 Radial angetriebenes Werkzeug vergrößert

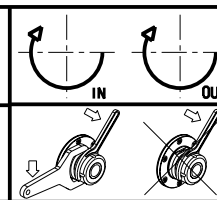

M.T. srl
 Via Casino Albini 480
 Tel. 0541/956034-957884
 Fax 0541/956341
 47842 S. GIOVANNI IN M. (RN)
 e-mail: mtma@mtmarchetti.com
 http://www.mtmarchetti.com



PAGINA MSL020-2-00

Subject to change without notice.

10/2021

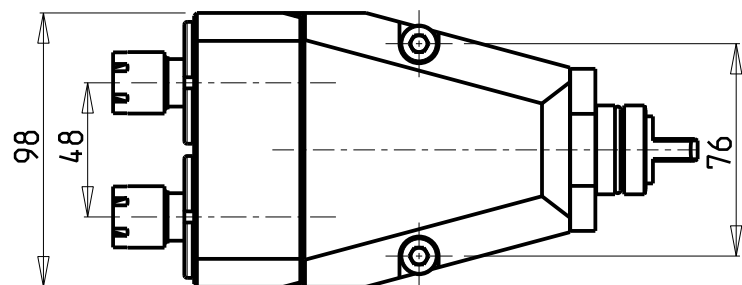
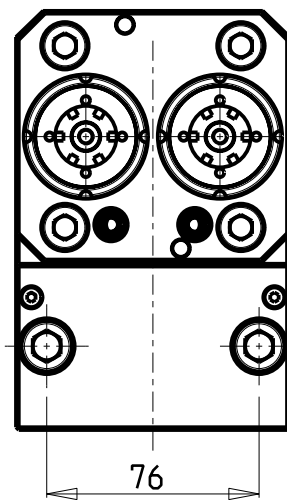
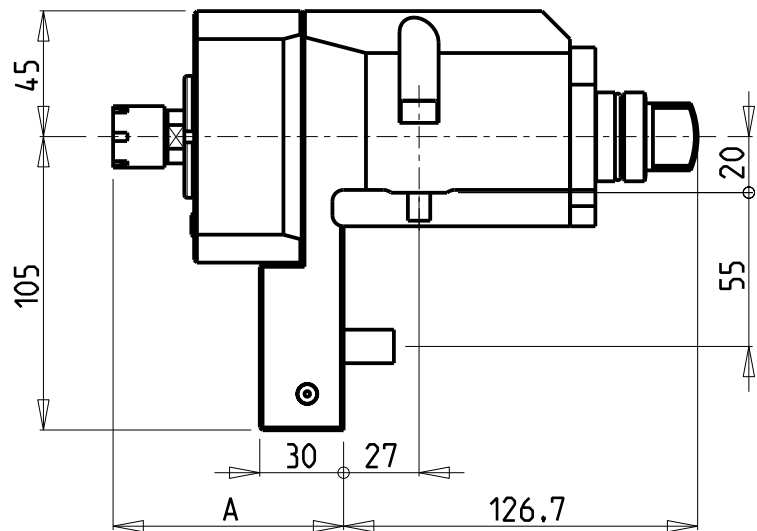

ATTENZIONE - ATTENTION - ACHTUNG

- Per lo smontaggio degli utensili utilizzare sempre la chiave di contrasto come indicato nel manuale d'uso.
- For disassembly of the tools use always the contrast key as mentioned in the user instructions.
- Fuer das Abmontieren der Werkzeuge immer den Gegenschlüssel benutzen wie in der Bedienungsanleitung erwäehnt.

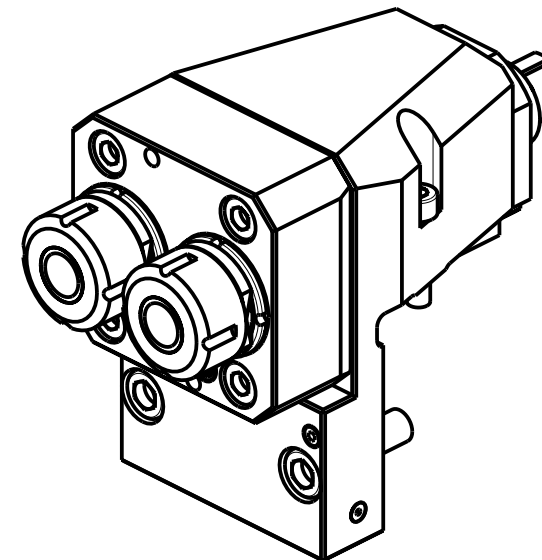

Cod. MT	Mandrino Spindle Spindel	I	RPM	Coppia Max Max Torque Max Drehmoment	Lubrificazione est. Ext. coolant Aussenkuehlung	A	CHIAVI NON INCLUSE Keys not included Schlüssel nicht einbegriffen	
							CHUB17	CHMNER16
M0300016	ER16	1:1	6000	30Nm	X	82.5	CHUB17	CHMNER16
M0300025	ER25	1:1	6000	30Nm	X	82.96	MNLO210007	CHSTER25

DMG-MORI
MOD: SL2500Y

MODULO MOTORIZZATO RADIALE 2 USCITE IN Y
Radial single side twin head driven tool in Y
Radial angetriebenes Werkzeug 2 Ausgaenge in Y

Subject to change without notice.

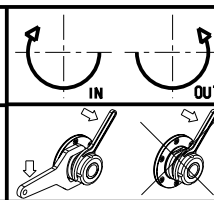

M.T. srl

Via Casino Albini 480
Tel. 0541/956034-957884
Fax 0541/956341
47842 S. GIOVANNI IN M. (RN)
e-mail: mtma@mtmarchetti.com
<http://www.mtmarchetti.com>



PAGINA MSL080-2-00

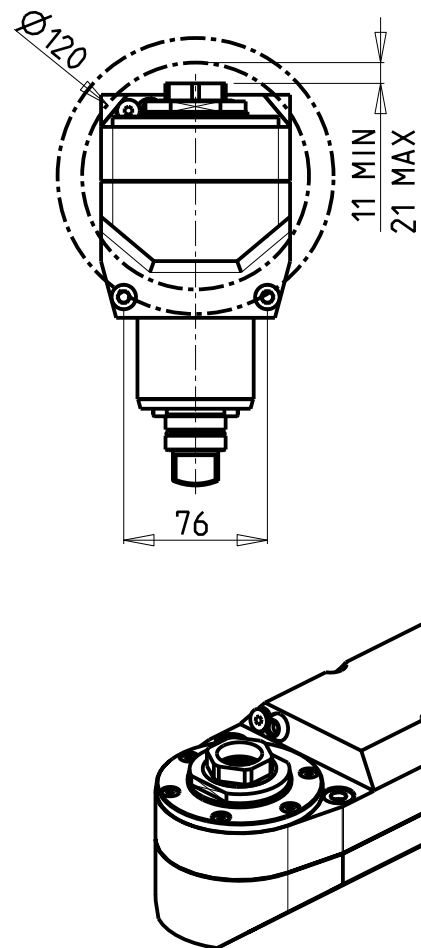
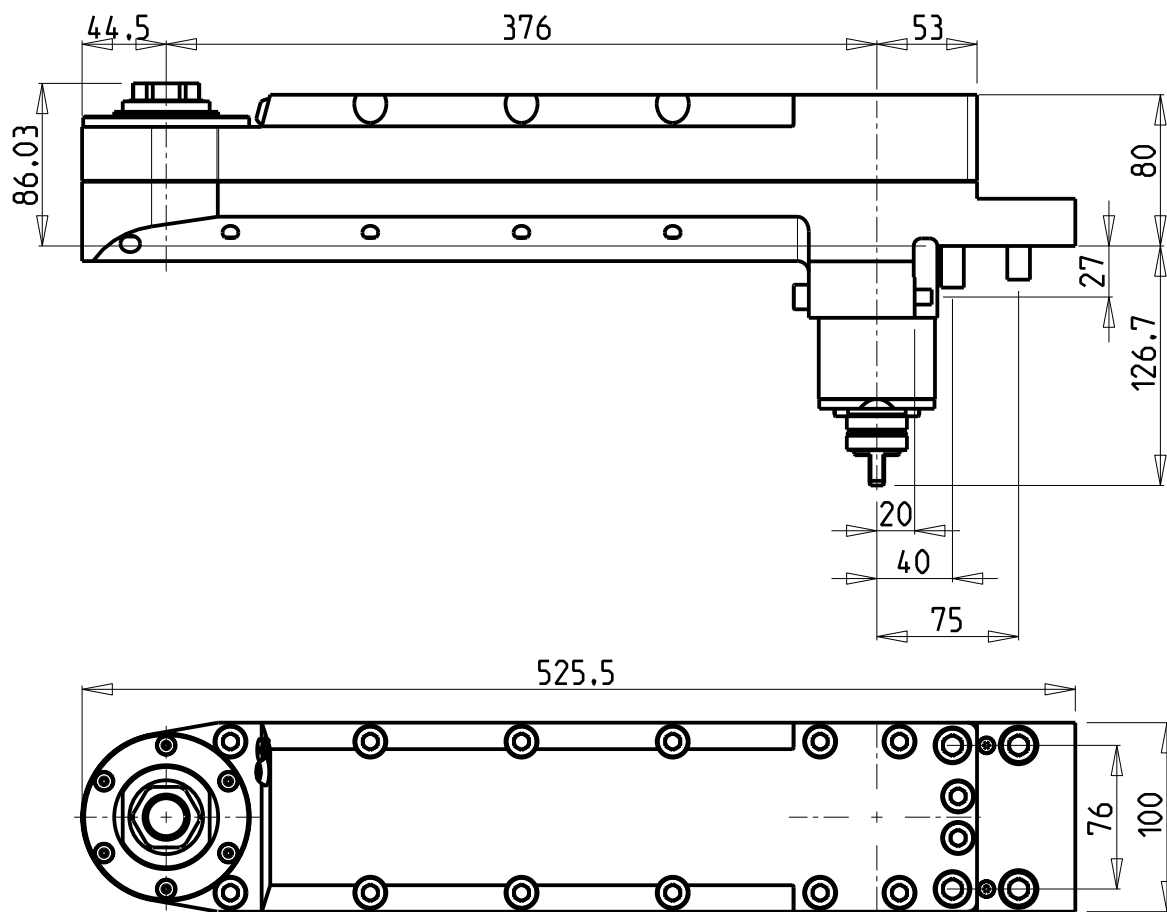

ATTENZIONE - ATTENTION - ACHTUNG

- Per lo smontaggio degli utensili utilizzare sempre la chiave di contrasto come indicato nel manuale d'uso.
- For disassembly of the tools use always the contrast key as mentioned in the user instructions.
- Fuer das Abmontieren der Werkzeuge immer den Gegenschlüssel benutzen wie in der Bedienungsanleitung erwaeht.

Cod. MT	Mandrino Spindle Spindel	I	RPM	Coppia Max Max Torque Max Drehmoment	Lubrificazione est. Ext. coolant Aussenkuehlung	CHIAVI INCLUSE Keys included Schluessel inbegriffen	
MSL0010132	ER A 32	1:1	6000	50Nm	X	CHUB46	CHUB32

DMG-MORI
 MOD: SL-ZL200/203/204/250/253/254(MC-SMC) SL2500Y DL-ZL200/250(MC)

MODULO MOTORIZZATO SPECIALE RADIALE DISASSATO IN Z 376mm
 Radial special driven tool re-directed in z by 376mm
 Radial spezial angetriebenes Werkzeug achsversetzt in z um 376mm

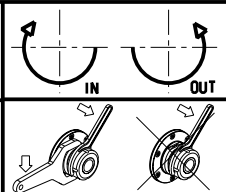

M.T. srl
 Via Casino Albini 480
 Tel. 0541/956034-957884
 Fax 0541/956341
 47842 S. GIOVANNI IN M. (RN)
 e-mail: mtma@mtmarchetti.com
 http://www.mtmarchetti.com



PAGINA MSL125-2-10

Subject to change without notice.

10/2021

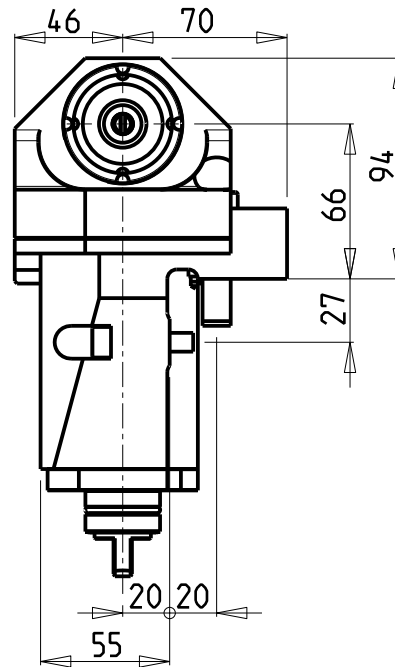
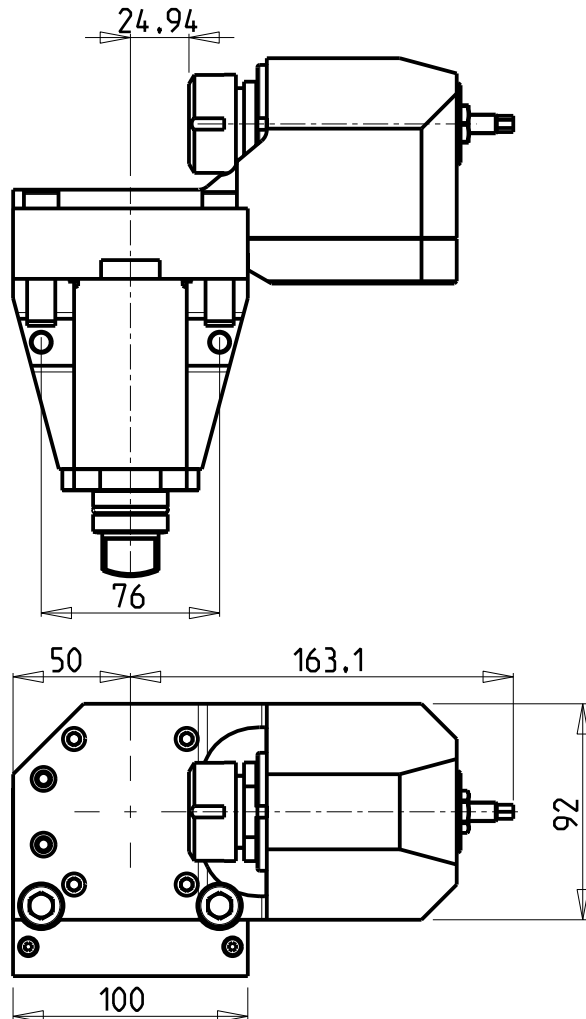

ATTENZIONE - ATTENTION - ACHTUNG

- Per lo smontaggio degli utensili utilizzare sempre la chiave di contrasto come indicato nel manuale d'uso.
- For disassembly of the tools use always the contrast key as mentioned in the user instructions.
- Fuer das Abmontieren der Werkzeuge immer den Gegenschlüssel benutzen wie in der Bedienungsanleitung erwaeht.

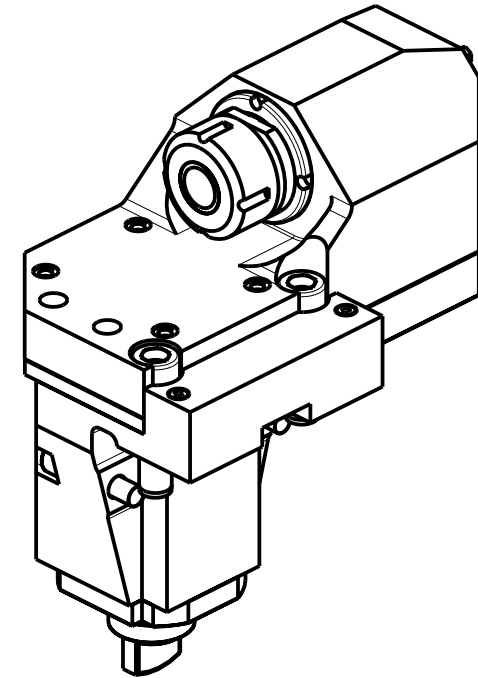

Cod. MT	Mandrino Spindle Spindel	I	RPM	Coppia Max Max Torque Max Drehmoment	Lubrificazione est. Ext. coolant Aussenkuehlung	CHIAVI NON INCLUSE Keys not included Schlüssel nicht einbegriffen	
M0230025	ER 25	1:1	6000	40Nm	X	CHUB36	CHSTER25

DMG-MORI

MOD: SL-ZL200/203/204/250/253/254(MC-SMC) SL2500Y DL-ZL200/250(MC)

MODULO MOTORIZZATO SPECIALE RADIALE IN Y

Radial special driven tool in Y

Radial spezial angetriebenes Werkzeug in Y

Subject to change without notice.

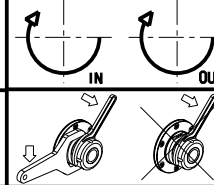

M.T. srl

Via Casino Albini 480
Tel. 0541/956034-957884

Fax 0541/956341

47842 S. GIOVANNI IN M. (RN)

e-mail: mtma@mtmarchetti.com

http://www.mtmarchetti.com



PAGINA MSL130-2-00

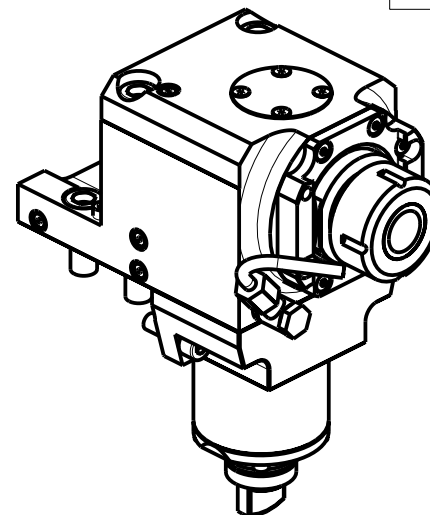
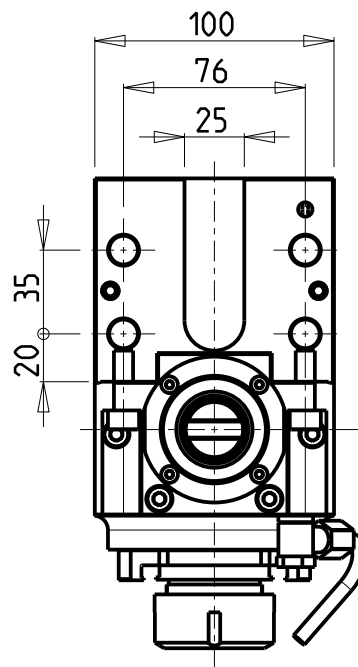
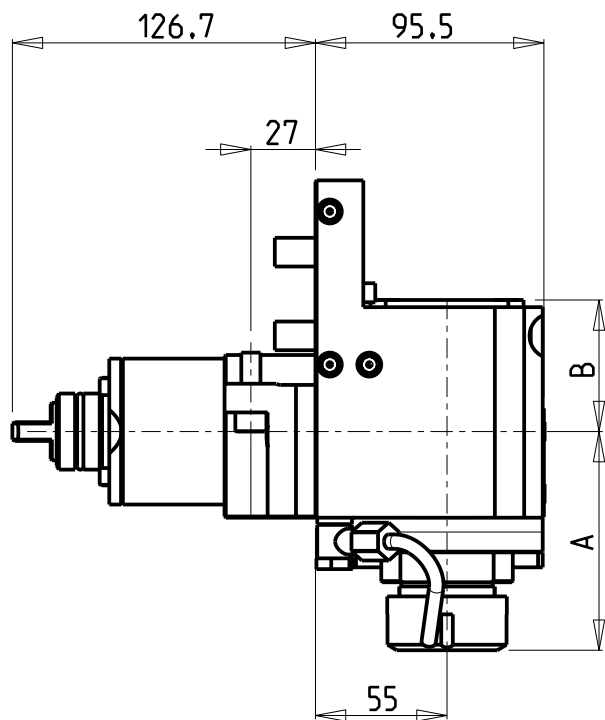

ATTENZIONE - ATTENTION - ACHTUNG

- Per lo smontaggio degli utensili utilizzare sempre la chiave di contrasto come indicato nel manuale d'uso.
- For disassembly of the tools use always the contrast key as mentioned in the user instructions.
- Fuer das Abmontieren der Werkzeuge immer den Gegenschlüssel benutzen wie in der Bedienungsanleitung erwaehtnt.

Cod. MT	Mandrino Spindle Spindel	I	RPM	Coppia Max Max Torque Max Drehmoment	Lubrificazione int. Coolant through Innenkuehlung	Lubrificazione est. Ext. coolant Aussenkuehlung	A	B	CHIAVI NON INCLUSE Keys not included Schluessel nicht einbegriffen	
MSL0160132	ER32	1:1	6000	70Nm	-	X	91.41	55	MNZ0410005 *	CHSTER32
MSL0160232	ER32	1:1	6000	70Nm	P=70bar	X	91.41	67.5	MNZ0410005 *	CHSTER32
MSL0160125	ER25	1:1	6000	70Nm	-	X	88.41	55	MNZ0410005 *	CHSTER25
MSL0160225	ER25	1:1	6000	70Nm	P=70bar	X	88.41	67.5	MNZ0410005 *	CHSTER25

- Chiave inclusa
- Key included
- Schluessel inbegriffen

DMG-MORI

MOD: SL-ZL200/203/204/250/253/254(MC-SMC) SL2500Y DL-ZL200/250(MC)

MODULO MOTORIZZATO ASSIALE

Axial driven tool

Axial angetriebenes Werkzeug

Subject to change without notice.

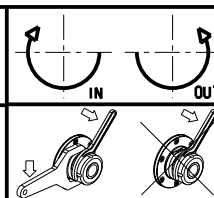

M.T. srl

Via Casino Albini 480
Tel. 0541/956034-957884
Fax 0541/956341
47842 S. GIOVANNI IN M. (RN)
e-mail: mtma@tmarchetti.com
http://www.tmmarchetti.com



PAGINA MSL150-2-10

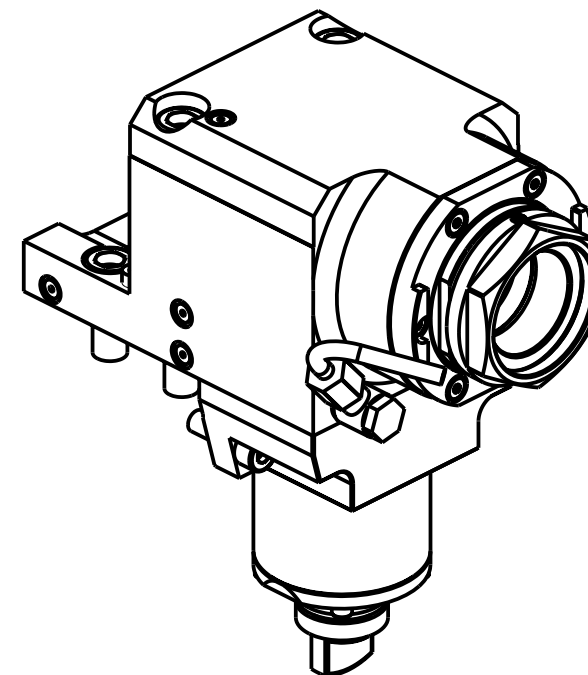
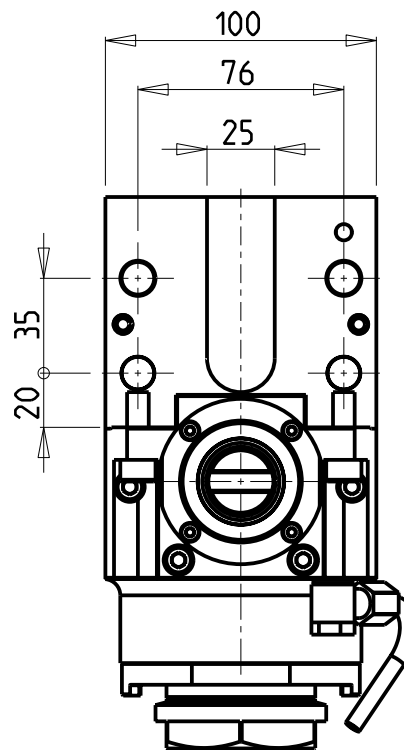
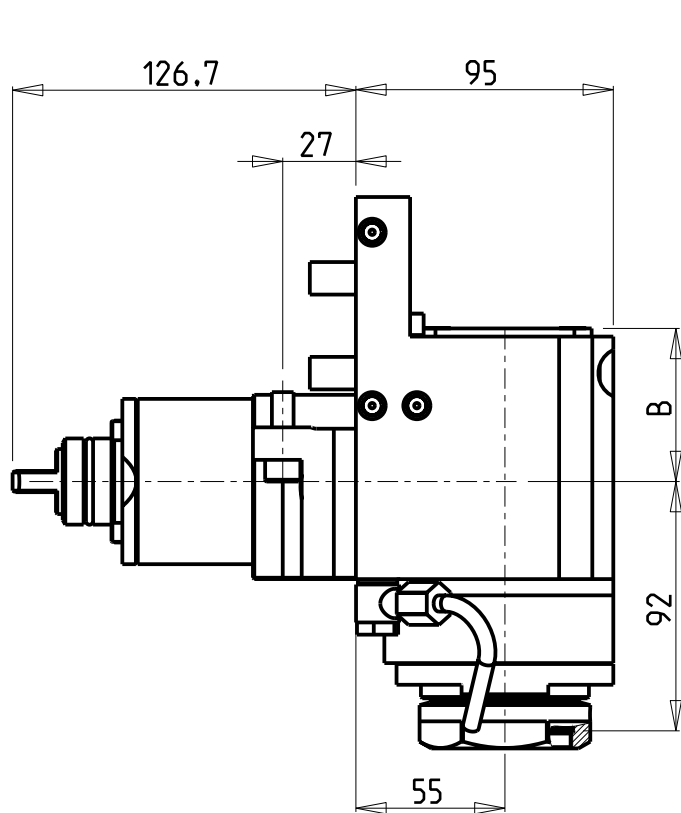

PER PORTAUTENSILI MODULARI MTSK-50 VEDI PAG. TBL300-1-50
 FOR MTSK-50 QUICK CHANGE TOOLHOLDERS CLAMPINGS SEE PAGE TBL300-1-50
 FUER MTSK-50 MODULARE WERKZEUGAUFNAHMEN SIEHE SEITE TBL300-1-50

- Chiave inclusa
- Key included
- Schluessel inbegriffen

Cod. MT	Mandrino Spindle Spindel	I	RPM	Coppia Max Max Torque Max Drehmoment	Lubr.interna Coolant through Innenkuehlung	Lubr.esterna Ext. coolant Aussenkuehlung	B	CHIAVI NON INCLUSE Keys not included Schluessel nicht einbegriffen	
MSL0370150	MTSK-50	1:1	6000	70Nm	-	X	56.5	CHUB55	OKU0430007 •
MSL0370250	MTSK-50	1:1	6000	70Nm	P=70bar	X	69	CHUB55	OKU0430007 •

DMG-MORI
 MOD: SL-ZL200/203/204/250/253/254(MC-SMC) SL2500Y DL-ZL200/250(MC)

MODULO MOTORIZZATO ASSIALE MTSK
 Axial MTSK driven tool
 Axial MTSK angetriebenes Werkzeug

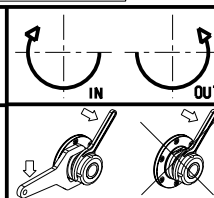

M.T. srl
 Via Casino Albini 480
 Tel. 0541/956034-957884
 Fax 0541/956341
 47842 S. GIOVANNI IN M. (RN)
 e-mail: mtma@mtmarchetti.com
 http://www.mtmarchetti.com



PAGINA MSL150-2-10-K

Subject to change without notice.

10/2021

ATTENZIONE - ATTENTION - ACHTUNG

- Per lo smontaggio degli utensili utilizzare sempre la chiave di contrasto come indicato nel manuale d'uso.
- For disassembly of the tools use always the contrast key as mentioned in the user instructions.
- Fuer das Abmontieren der Werkzeuge immer den Gegenschlüssel benutzen wie in der Bedienungsanleitung erwäehnt.

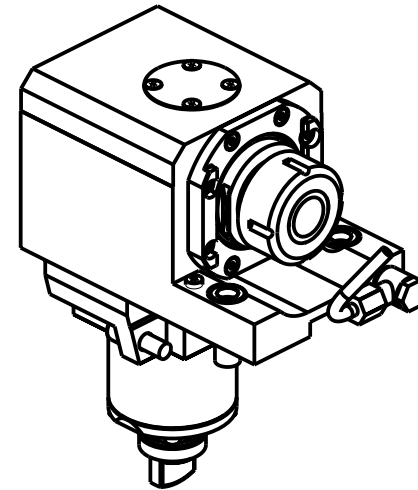
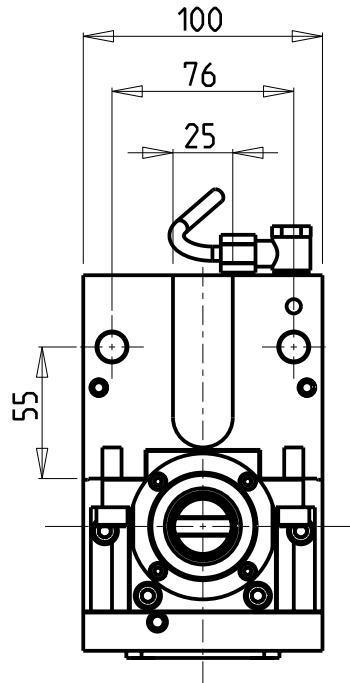
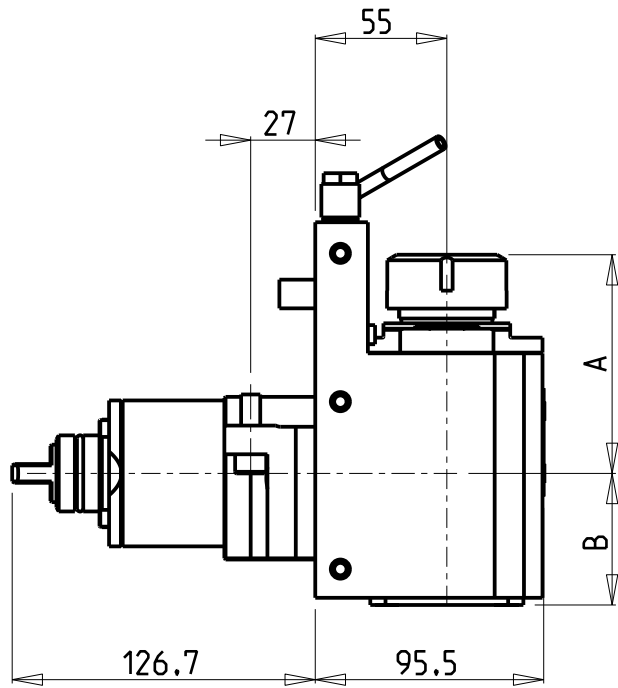

Cod. MT	Mandrino Spindle Spindel	I	RPM	Coppia Max Max Torque Max Drehmoment	Lubrificazione int. Coolant through Innenkuehlung	Lubrificazione est. Ext. coolant Aussenkuehlung	A	B	CHIAVI NON INCLUSE Keys not included Schluessel nicht einbegriffen	
MSL0570132	ER32	1:1	6000	70Nm	-	X	91.41	55	MNZ0410005 *	CHSTER32
MSL0570232	ER32	1:1	6000	70Nm	P=70bar	X	91.41	67.5	MNZ0410005 *	CHSTER32
MSL0570125	ER25	1:1	6000	70Nm	-	X	88.41	55	MNZ0410005 *	CHSTER25
MSL0570225	ER25	1:1	6000	70Nm	P=70bar	X	88.41	67.5	MNZ0410005 *	CHSTER25

- Chiave inclusa
- Key included
- Schluessel inbegriffen

DMG-MORI

MOD: SL-ZL200/203/204/250/253/254(MC-SMC) SL2500Y DL-ZL200/250(MC)

MODULO MOTORIZZATO ASSIALE PER CONTROMANDRINO H=55mm

Axial driven tool for subspindle H=55mm

Axial angetriebenes Werkzeug fuer Gegenspindel H=55mm

Subject to change without notice.

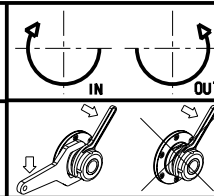

M.T. srl

Via Casino Albini 480
Tel. 0541/956034-957884
Fax 0541/956341

47842 S. GIOVANNI IN M. (RN)
e-mail: mtma@mtmarchetti.com
http://www.mtmarchetti.com



PAGINA MSL155-2-10

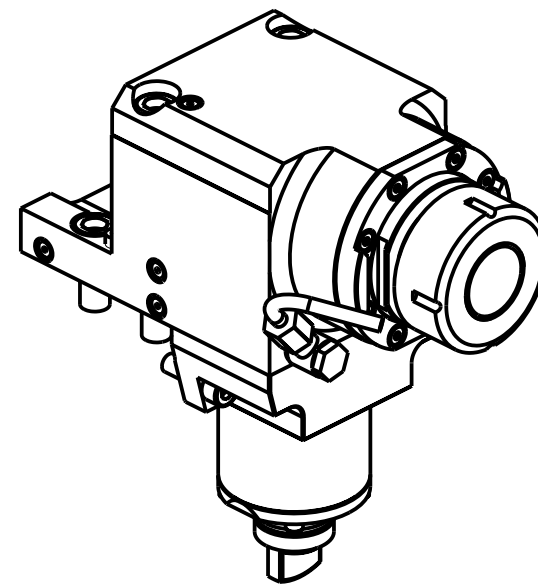
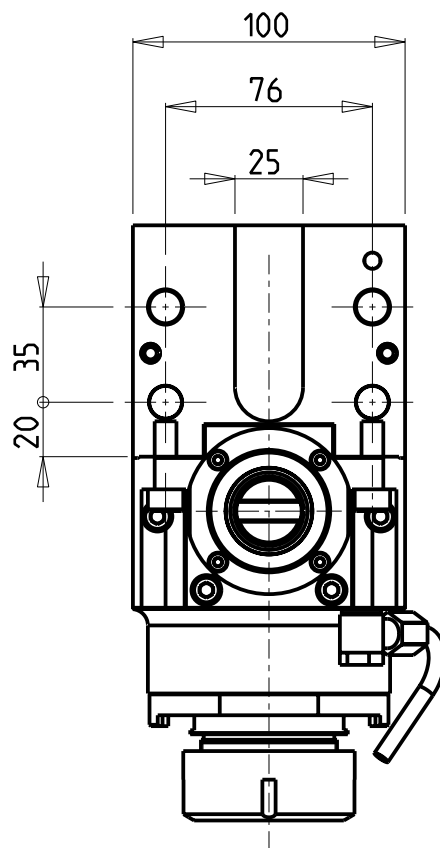
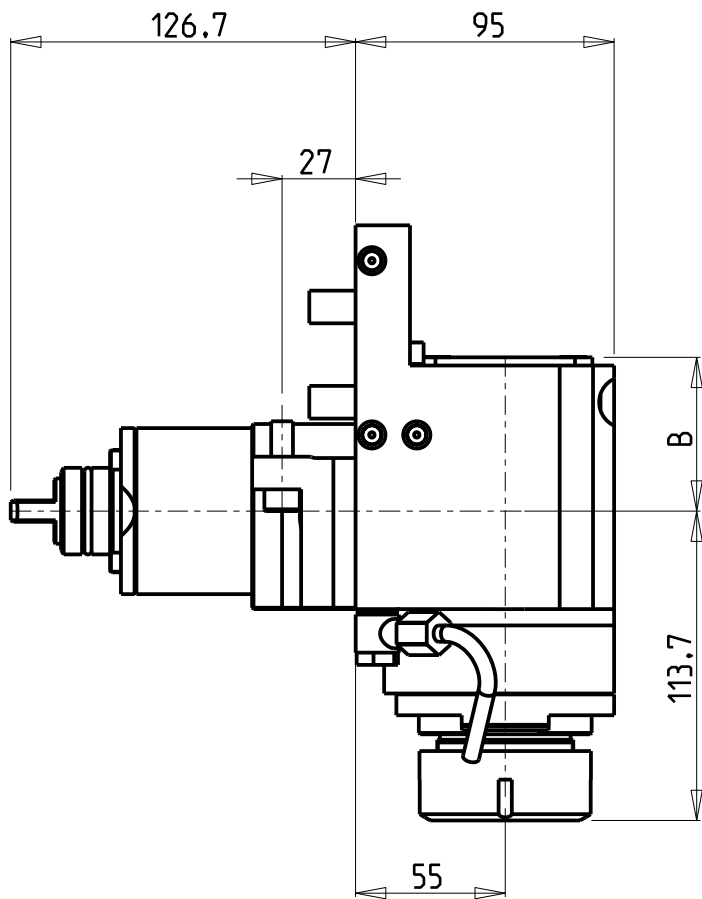

ATTENZIONE - ATTENTION - ACHTUNG

- Per lo smontaggio degli utensili utilizzare sempre la chiave di contrasto come indicato nel manuale d'uso.
- For disassembly of the tools use always the contrast key as mentioned in the user instructions.
- Fuer das Abmontieren der Werkzeuge immer den Gegenschlüssel benutzen wie in der Bedienungsanleitung erwäehnt.

Cod. MT	Mandrino Spindle Spindel	I	RPM	Coppia Max Max Torque Max Drehmoment	Lubrificazione int. Coolant through Innenkuehlung	Lubrificazione est. Ext. coolant Aussenkuehlung	B	CHIAVI NON INCLUSE Keys not included Schlüssel nicht einbegriffen	
MSL0480140	ER40	1:1	6000	70Nm	-	X	56.5	OKU0430007	CHSTER40
MSL0480240	ER40	1:1	6000	70Nm	P=70bar	X	69	OKU0430007	CHSTER40

- Chiave inclusa
- Key included
- Schlüssel inbegriffen

DMG-MORI

MOD: SL-ZL200/203/204/250/253/254(MC-SMC) SL2500Y DL-ZL200/250(MC)

MODULO MOTORIZZATO ASSIALE MAGGIORATO H=55mm

Axial reinforced driven tool H=55mm

Axial angetriebenes Werkzeug vergrößert H=55mm

Subject to change without notice.

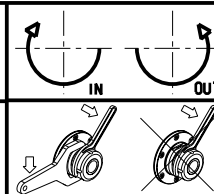

M.T. srl

Via Casino Albini 480
Tel. 0541/956034-957884
Fax 0541/956341

47842 S. GIOVANNI IN M. (RN)
e-mail: mtma@mtmarchetti.com
http://www.mtmarchetti.com



PAGINA MSL170-2-10

ATTENZIONE - ATTENTION - ACHTUNG

- Per lo smontaggio degli utensili utilizzare sempre la chiave di contrasto come indicato nel manuale d'uso.
- For disassembly of the tools use always the contrast key as mentioned in the user instructions.
- Fuer das Abmontieren der Werkzeuge immer den Gegenschlüssel benutzen wie in der Bedienungsanleitung erwäehnt.

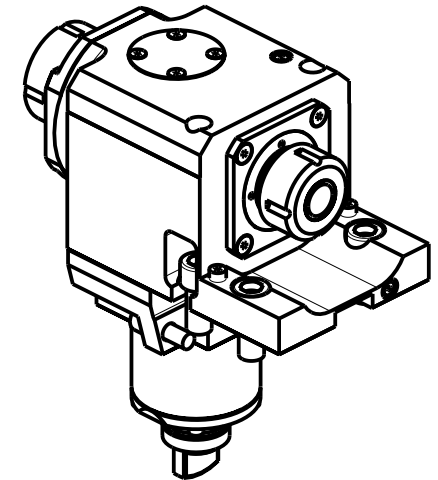
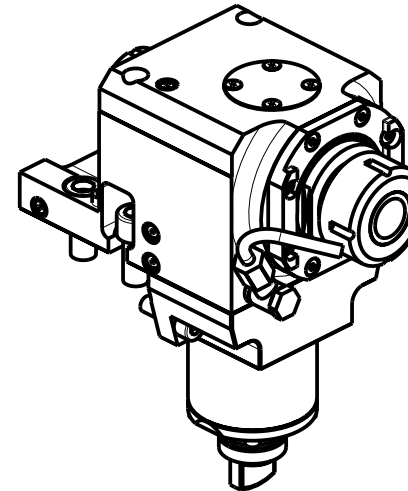
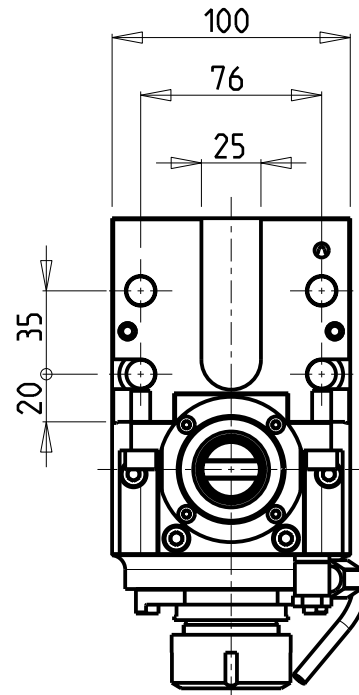
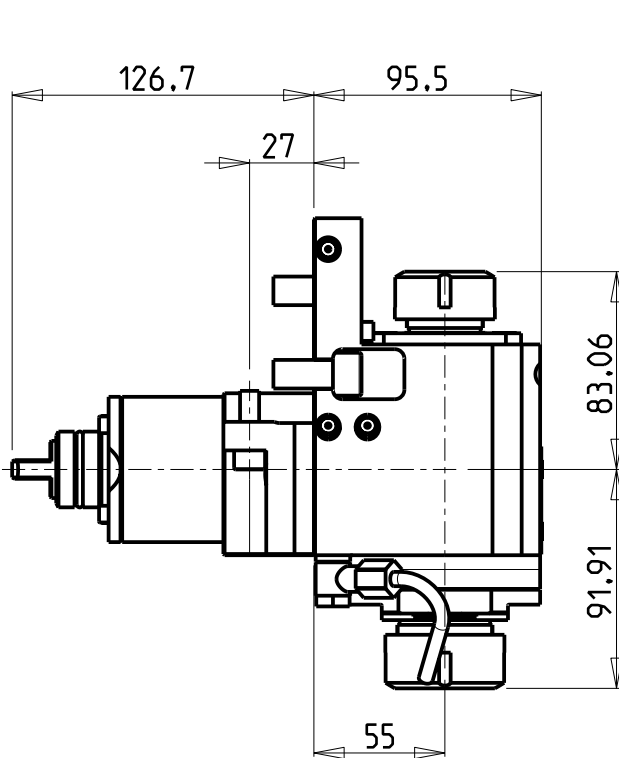

• Chiave inclusa

• Key included

• Schlüssel inbegriffen

Cod. MT	Mandrino Spindle Spindel	I	RPM	Coppia Max Max Torque Max Drehmoment	Lubrificazione est. Ext. coolant Aussenkuehlung	CHIAVI NON INCLUSE Keys not included Schlüssel nicht einbegriffen		
MSL0173225	ER32+ER25	1:1	6000	70Nm	X	MNZ0410005 •	CHSTER32	CHSTER25

DMG-MORI

MOD: SL-ZL200/203/204/250/253/254(MC-SMC) SL2500Y DL-ZL200/250(MC)

MODULO MOTORIZZATO ASSIALE BISPORGENTE

Axial opposite face twin driven tool

Axial angetriebenes Werkzeug halb vorspringend

Subject to change without notice.

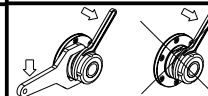

M.T. srl

Via Casino Albini 480
Tel. 0541/956034-957884
Fax 0541/956341
47842 S. GIOVANNI IN M. (RN)
e-mail: mtma@mtmarchetti.com
http://www.mtmarchetti.com



PAGINA MSL240-2-10

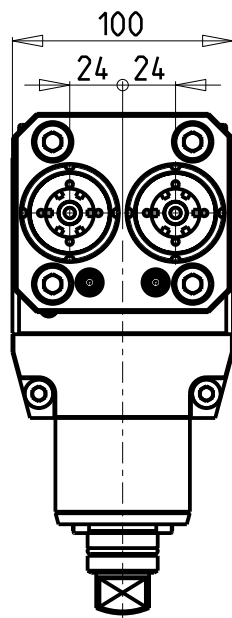
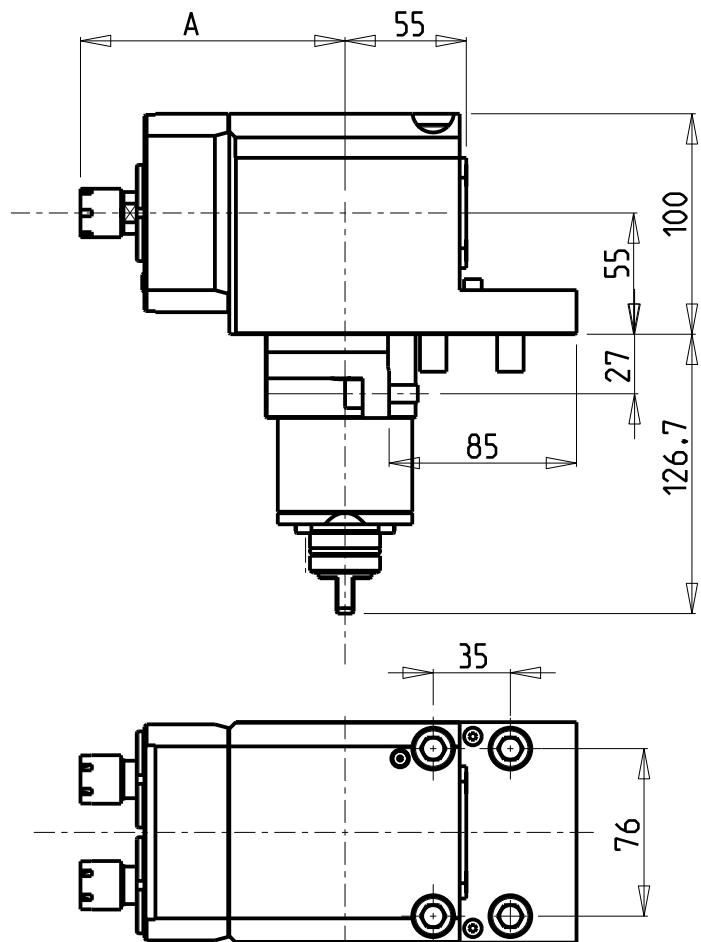

ATTENZIONE - ATTENTION - ACHTUNG

- Per lo smontaggio degli utensili utilizzare sempre la chiave di contrasto come indicato nel manuale d'uso.
- For disassembly of the tools use always the contrast key as mentioned in the user instructions.
- Fuer das Abmontieren der Werkzeuge immer den Gegenschlüssel benutzen wie in der Bedienungsanleitung erwäehnt.

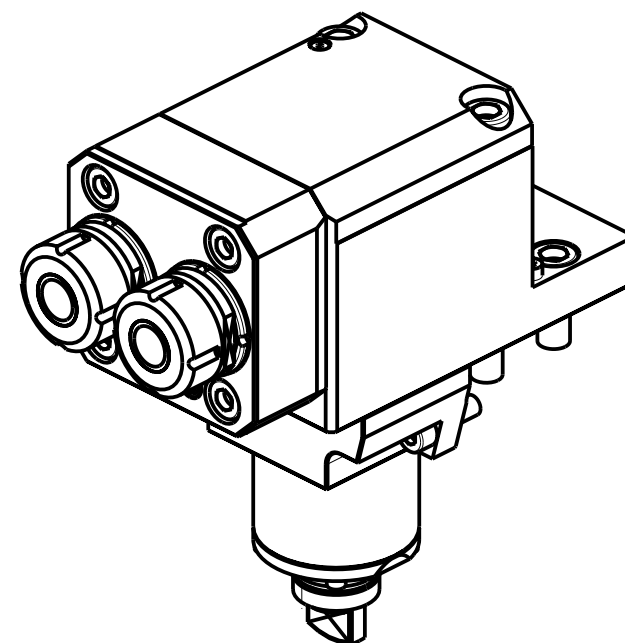

Cod. MT	Mandrino Spindle Spindel	I	RPM	Coppia Max Max Torque Max Drehmoment	Lubrificazione est. Ext. coolant Aussekkuehlung	A	CHIAVI NON INCLUSE Keys not included Schlüssel nicht einbegriffen	
MSL0180216	ER16	1:1	6000	30Nm	X	120	CHUB17	CHMNER16
MSL0180225	ER25	1:1	6000	30Nm	X	121	MNL0210007	CHSTER25

DMG-MORI
MOD: SL2500Y

MODULO MOTORIZZATO ASSIALE 2 USCITE IN Y
Axial single side twin head driven tool in Y
Axial angetriebenes Werkzeug 2 Ausgaenge in Y

Subject to change without notice.

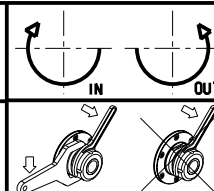

M.T. srl

Via Casino Albini 480
Tel. 0541/956034-957884
Fax 0541/956341
47842 S. GIOVANNI IN M. (RN)
e-mail: mtma@mtmarchetti.com
<http://www.mtmarchetti.com>



PAGINA MSL260-2-10

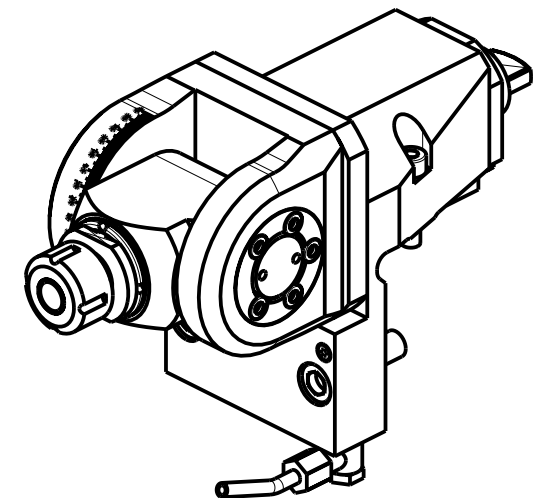
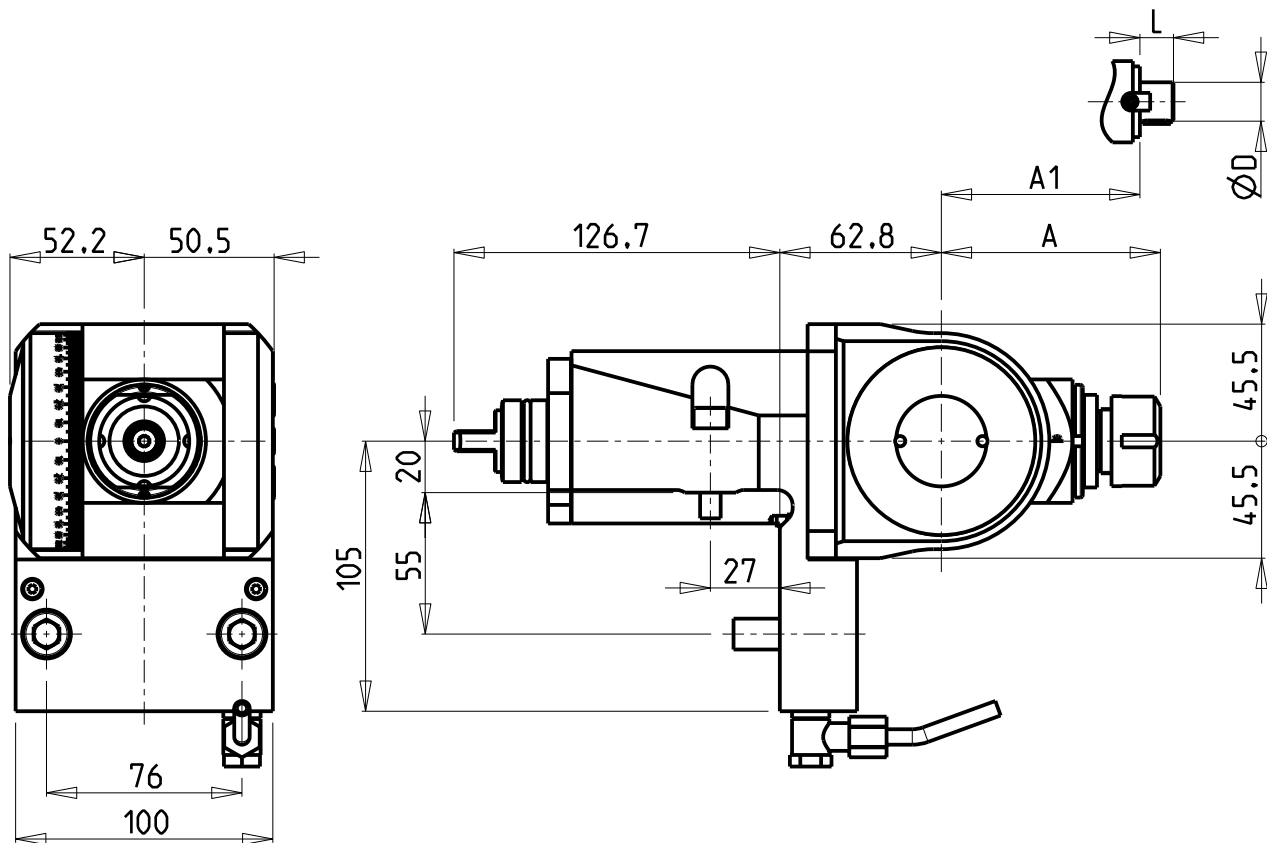

Cod. MT	Mandrino Spindle Spindel	I	RPM	Coppia Max Max Torque Max Drehmoment	Lubrificazione est. Ext. coolant Aussenkuehlung	A	A1	D	L	CHIAVI INCLUSE Keys included Schlüssel inbegriffen	
MSL0230120	ER20	1:1	6000	40Nm	X	85.16	-	-	-	CHUB36	CHSTER20
MSL0230125	ER25	1:1	6000	40Nm	X	86.16	-	-	-	CHUB36	CHSTER25
MSL0230516	Ø16x17	1:1	6000	40Nm	X	-	65	16	17	CHUB36	CH_VTCROCE_M08
MSL0230522	Ø22x19	1:1	6000	40Nm	X	-	66	22	19	CHUB36	CH_VTCROCE_M10
MSL0230519	Ø3/4"x3/4"	1:1	6000	40Nm	X	-	65	3/4"	3/4"	CHUB36	CH_VTCROCE_M08

DMG-MORI

MOD: SL-ZL200/203/204/250/253/254(MC-SMC) SL2500Y DL-ZL200/250(MC)

MODULO MOTORIZZATO ORIENTABILE ±90°

±90° adjustable angle driven tool

Angetriebenes Werkzeug schwenkbar ±90°

Subject to change without notice.

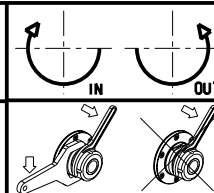

M.T. srl

Via Casino Albini 480
Tel. 0541/956034-957884

Fax 0541/956341

47842 S. GIOVANNI IN M. (RN)
e-mail: mtma@mtmarchetti.com
http://www.mtmarchetti.com



PAGINA MSL333-2-00

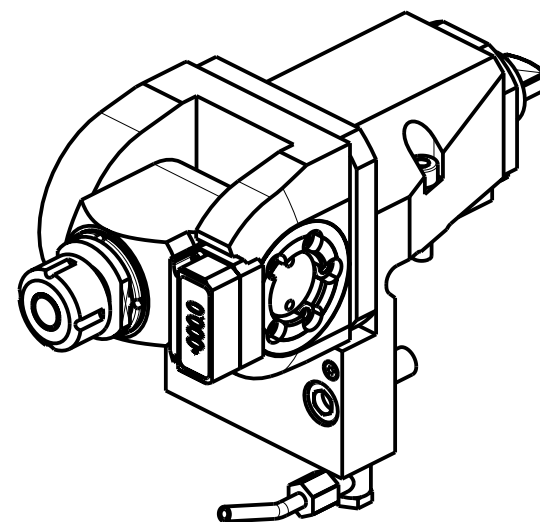
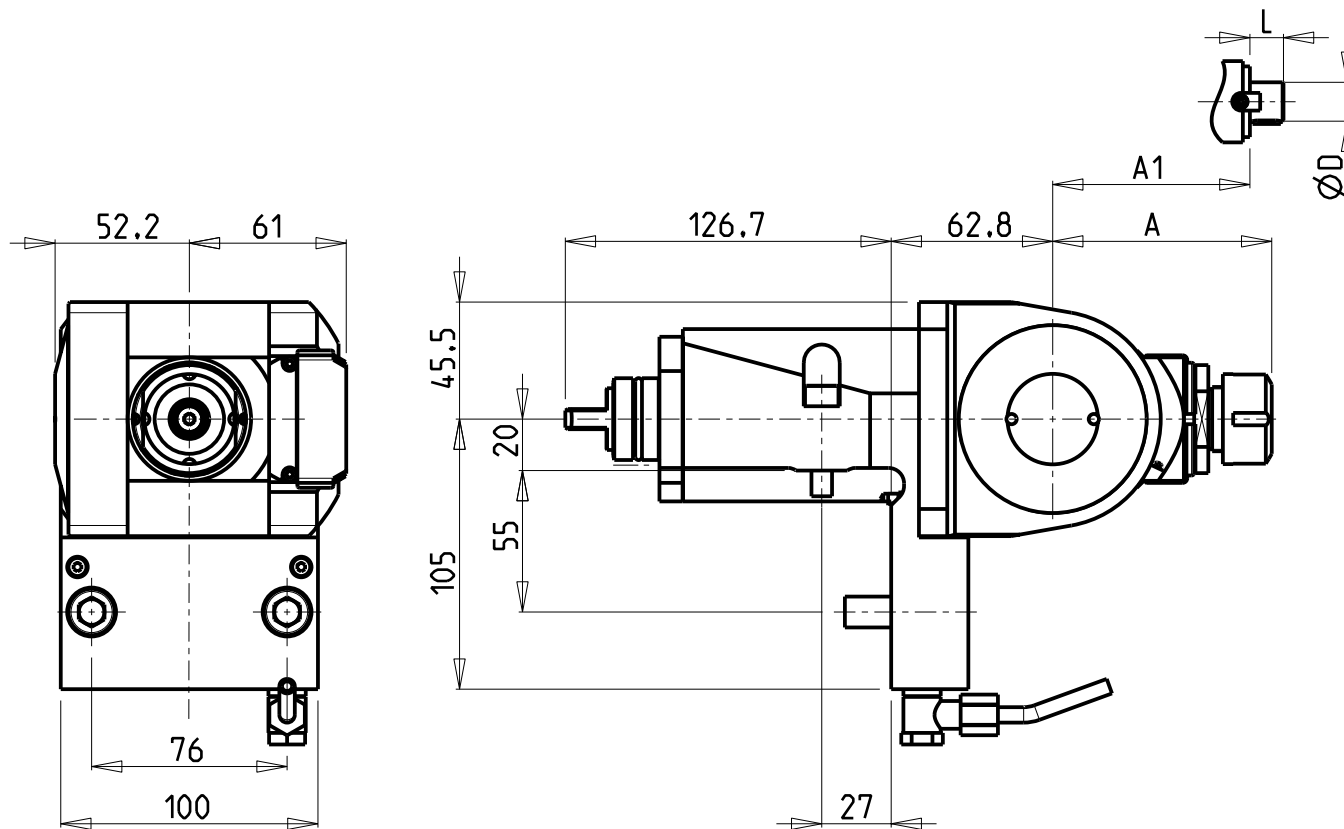

Cod. MT	Mandrino Spindle Spindel	I	RPM	Coppia Max Max Torque Max Drehmoment	Lubrificazione est. Ext. coolant Aussenkuehlung	A	A1	D	L	CHIAVI INCLUSE Keys included Schlüssel inbegriffen	
MSL0190120	ER20	1:1	6000	40Nm	X	85.16	-	-	-	CHUB36	CHSTER20
MSL0190125	ER25	1:1	6000	40Nm	X	86.16	-	-	-	CHUB36	CHSTER25
MSL0190516	Ø16x17	1:1	6000	40Nm	X	-	65	16	17	CHUB36	CH_VTCROCE_M08
MSL0190522	Ø22x19	1:1	6000	40Nm	X	-	66	22	19	CHUB36	CH_VTCROCE_M10
MSL0190519	Ø3/4"x3/4"	1:1	6000	40Nm	X	-	65	3/4"	3/4"	CHUB36	CH_VTCROCE_M08

DMG-MORI

MOD: SL-ZL200/203/204/250/253/254(MC-SMC) SL2500Y DL-ZL200/250(MC)

MODULO MOTORIZZATO ORIENTABILE ±90° CON NONIO DIGITALE

±90° adjustable angle driven tool with digital display

Angetriebenes Werkzeug schwenkbar ±90° mit digital display

Subject to change without notice.

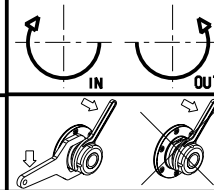

M.T. srl

Via Casino Albini 480
Tel. 0541/956034-957884
Fax 0541/956341

47842 S. GIOVANNI IN M. (RN)
e-mail: mtma@mtmarchetti.com
http://www.mtmarchetti.com



PAGINA MSL333-2-01

ATTENZIONE - ATTENTION - ACHTUNG

- Per lo smontaggio degli utensili utilizzare sempre la chiave di contrasto come indicato nel manuale d'uso.
- For disassembly of the tools use always the contrast key as mentioned in the user instructions.
- Fuer das Abmontieren der Werkzeuge immer den Gegenschluessel benutzen wie in der Bedienungsanleitung erwaeht.

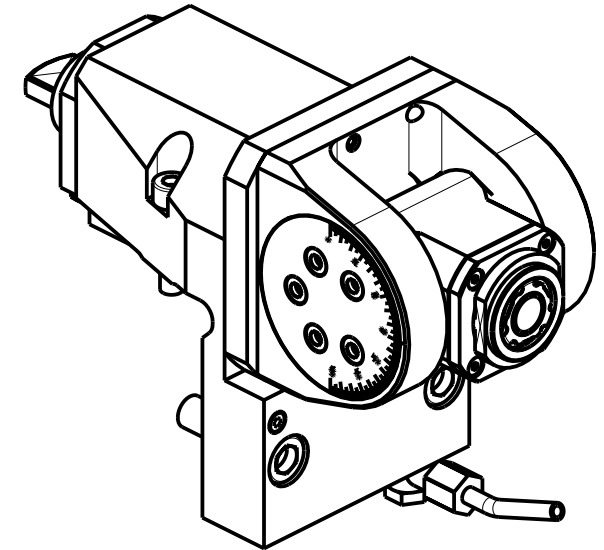
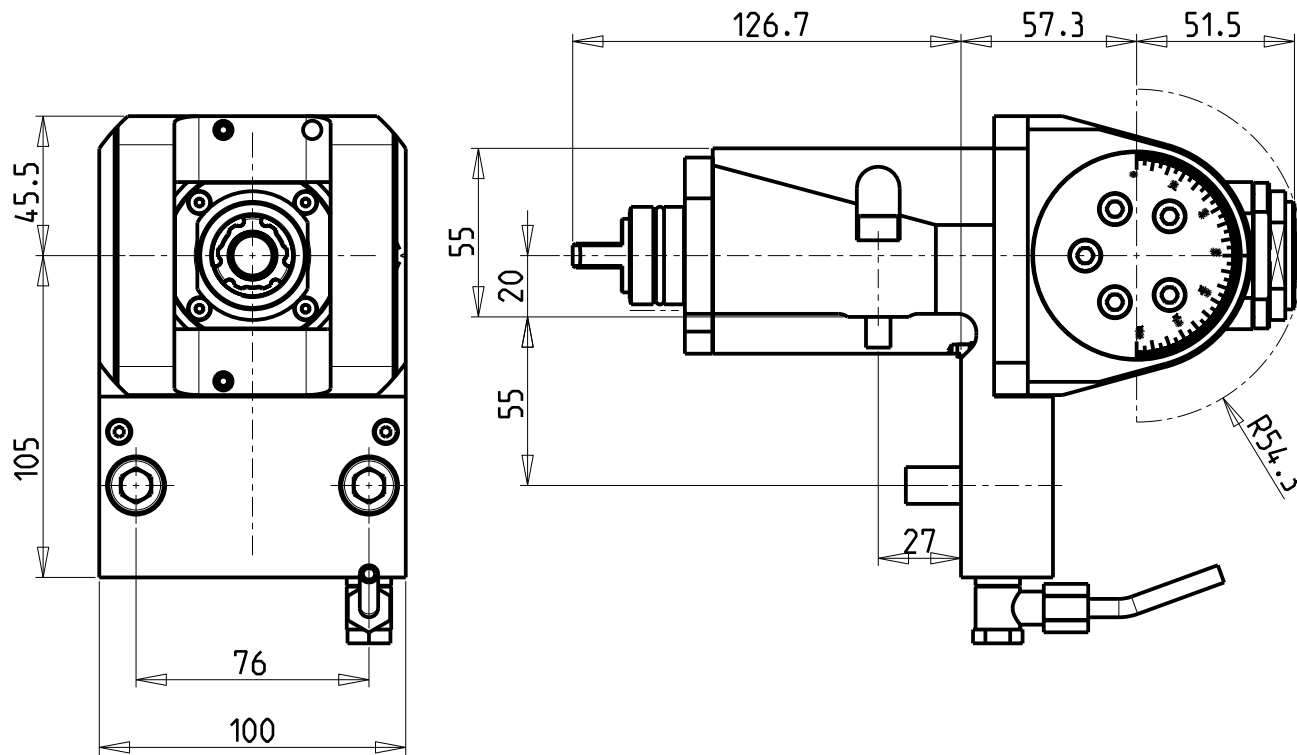

Cod. MT	Mandrino Spindle Spindel	I	RPM	Coppia Max Max Torque Max Drehmoment	Lubrificazione est. Ext. coolant Aussenkuehlung	CHIAVI INCLUSE Keys included Schluessel inbegriffen		
						CHUB36	CHUB22	CHTAER20ZC
M0220020	ER A 20	1:1	6000	30Nm	X	CHUB36	CHUB22	CHTAER20ZC

DMG-MORI
 MOD: SL-ZL200/203/204/250/253/254(MC-SMC) SL2500Y DL-ZL200/250(MC)

MODULO MOTORIZZATO ORIENTABILE ±90°
 ±90° adjustable angle driven tool
 Angetriebenes Werkzeug schwenkbar ±90°

Subject to change without notice.

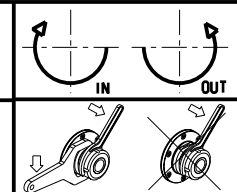

M.T. srl
 Via Casino Albini 480
 Tel. 0541/956034-957884
 Fax 0541/956341
 47842 S. GIOVANNI IN M. (RN)
 e-mail: mtma@mtmarchetti.com
 http://www.mtmarchetti.com



PAGINA MSL335-2-00

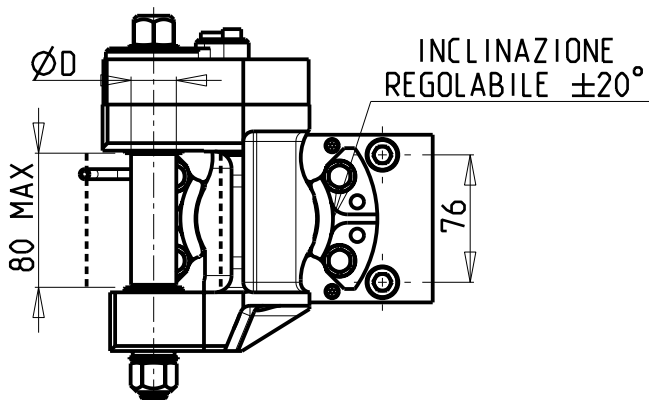
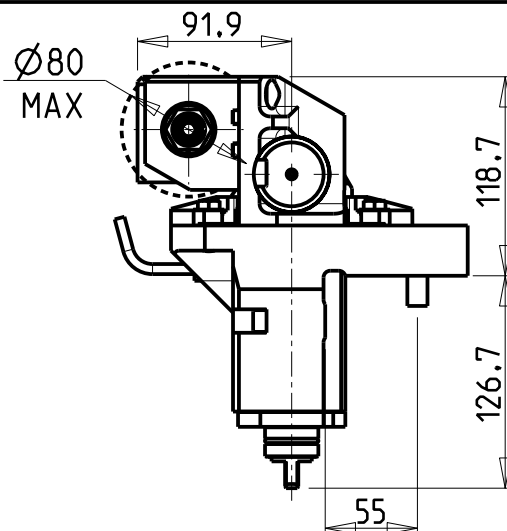
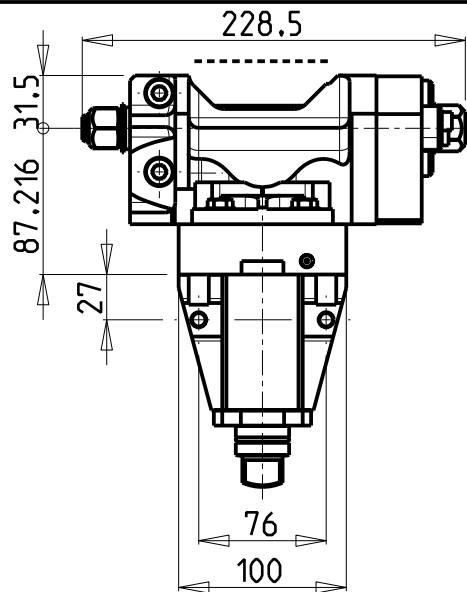

ATTENZIONE - ATTENTION - ACHTUNG

- E' consigliato l'utilizzo su torni dotati di controllo dell'asse Y
- It is recommended to use lathes with the required control of the Y-axis.
- Es ist empfehlenswert Drehbänke, ausgerüstet mit Kontrolle der Y-Achse, zu gebrauchen.

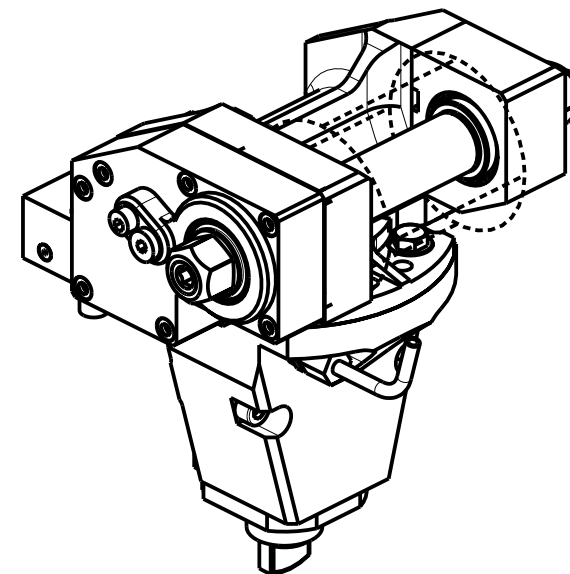

PER ALBERI E DISTANZIALI VEDI PAG. TBL250-1-00
 FOR SHAFT END SPACER SEE PAGE TBL250-1-00
 FUER DORN UND ABSTANDSSTUECK SEITE TBL250-1-00

DOTAZIONI - SUPPLIED WITH - AUSSTATTUNG

- | | |
|-----------|---|
| mm / inch | - N°1 ALBERO + DISTANZIALI
- N°1 SHAFT + SPACER
- N°1 DORN + ABSTANDSSTUECK |
|-----------|---|

Cod. MT	I	RPM max	Coppia Max Max Torque Max Drehmoment	Lubrificazione est. Ext. coolant Aussenkuehlung	D (mm)	D (Inch)	CHIAVI INCLUSE Keys included Schlüssel inbegriffen		
							CHUB24	CHUB13	CHESL08
M0081100	1:1	6000	60Nm	X	16-22-27-32	3/4"-1"-1 1/4"	CHUB24	CHUB13	CHESL08
M0082100	2:1	3000	80Nm	X	16-22-27-32	3/4"-1"-1 1/4"	CHUB24	CHUB13	CHESL08

DMG-MORI

MOD: SL-ZL200/203/204/250/253/254(MC-SMC) SL2500Y DL-ZL200/250(MC)

MODULO MOTORIZZATO PORTACREATORE

Driven gear hobber

Angetriebenes Zahnradwaeltzraes-Werkzeug

Subject to change without notice.

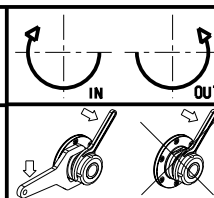

M.T. srl

Via Casino Albini 480
 Tel. 0541/956034-957884
 Fax 0541/956341
 47842 S. GIOVANNI IN M. (RN)
 e-mail: mtma@mtmarchetti.com
 http://www.mtmarchetti.com



PAGINA MSL340-2-00

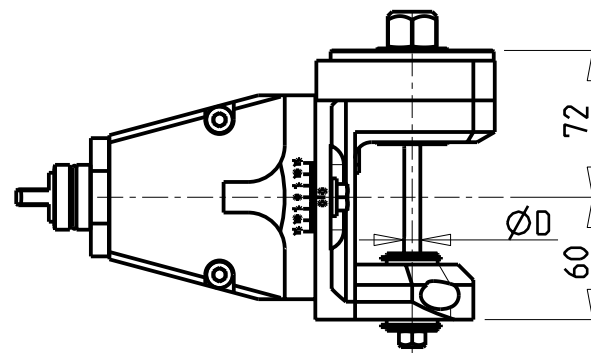
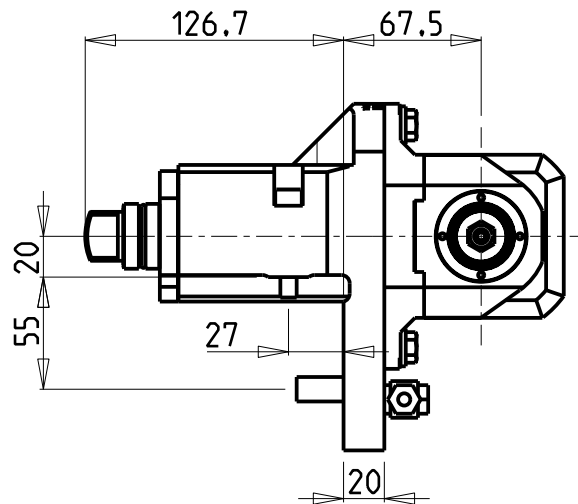
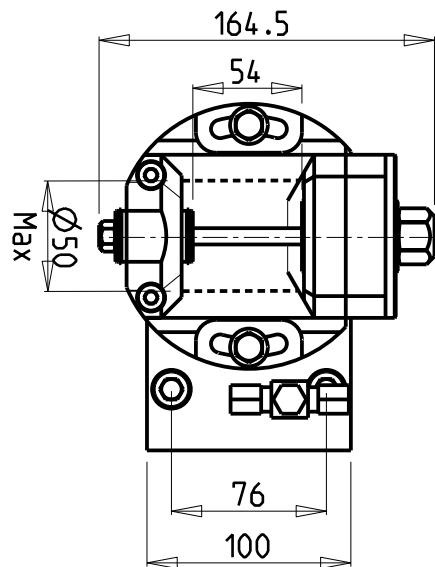

ATTENZIONE - ATTENTION - ACHTUNG

- E' consigliato l'utilizzo su torni dotati di controllo dell'asse Y
- It is recommended to use lathes with the required control of the Y-axis.
- Es ist empfehlenswert Drehbänke, ausgerüstet mit Kontrolle der Y-Achse, zu gebrauchen.

INCLINAZIONE
REGOLABILE ±15°

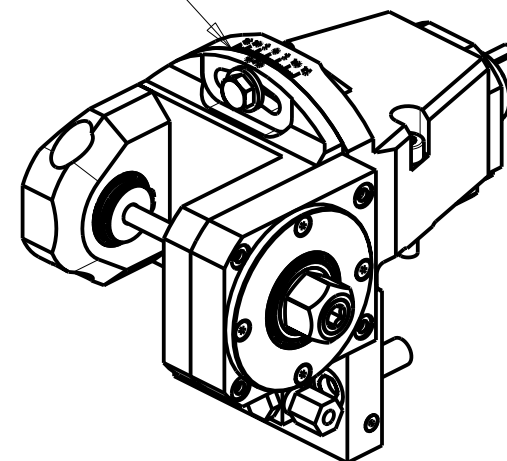

Cod. MT	i	RPM max	Coppia Max Max Torque Max Drehmoment	Lubrificazione est. Ext. coolant Aussenkuehlung	D	CHIAVI INCLUSE Keys included Schluessel inbegriffen				
						CHUB24	CHUB13	CHESL08	CHESL04	-
M0311108	1:1	6000	50Nm	X	8	CHUB24	CHUB13	CHESL08	CHESL04	-
M0311110	1:1	6000	50Nm	X	10	CHUB24	CHUB17	CHUB13	CHESL08	CHESL05
M0311113	1:1	6000	50Nm	X	13	CHUB24	CHUB19	CHUB13	CHESL08	CHESL06
M0311116	1:1	6000	50Nm	X	16	CHUB24	CHUB13	CHESL08	-	-

DMG-MORI

MOD: SL-ZL200/203/204/250/253/254(MC-SMC) SL2500Y DL-ZL200/250(MC)

MODULO MOTORIZZATO PORTACREATORE RADIALE

Radial driven gear hobber

Radial angetriebenes Waelzfraes-Werkzeug

Subject to change without notice.

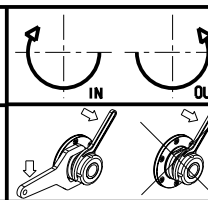

M.T. srl

Via Casino Albini 480
Tel. 0541/956034-957884

Fax 0541/956341

47842 S. GIOVANNI IN M. (RN)

e-mail: mtma@mtmarchetti.com

http://www.mtmarchetti.com



PAGINA MSL340-2-30

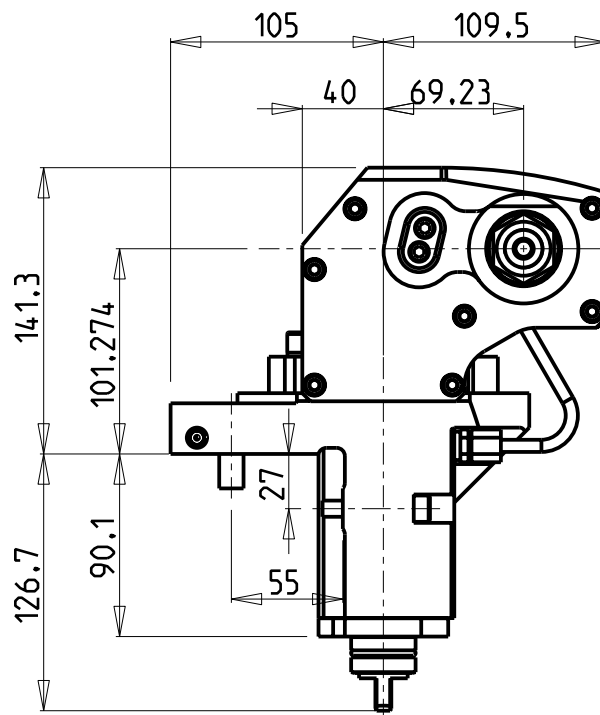
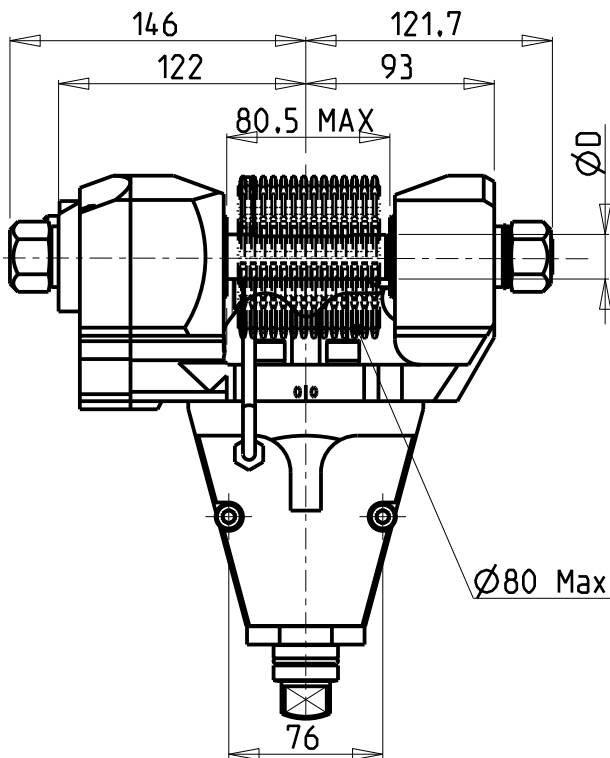

ATTENZIONE - ATTENTION - ACHTUNG

- E' consigliato l'utilizzo su torni dotati di controllo dell'asse Y
- It is recommended to use lathes with the required control of the Y-axis.
- Es ist empfehlenswert Drehbänke, ausgerüstet mit Kontrolle der Y-Achse, zu gebrauchen.

ATTENZIONE - ATTENTION - ACHTUNG

- VERIFICARE LE MISURE DI INGOMBRO PER POSSIBILE INTERFERENZA SU ALCUNI MODELLI DI MACCHINE
- Please check the overall sizes for possible interferences on some machine models
- Bitte überprüfen sie das ausmass um mögliche interferenzen auf einigen maschinen modellen zu vermeiden

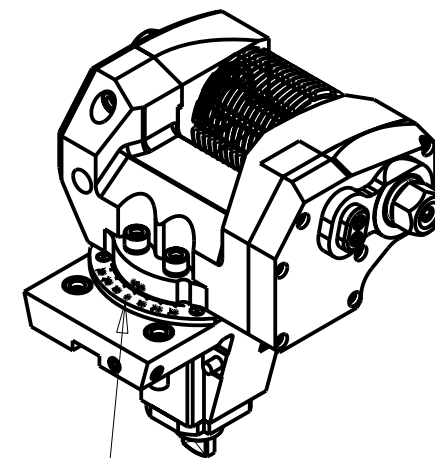

INCLINAZIONE
REGOLABILE ±30°

DOTAZIONI - SUPPLIED WITH - AUSSTATTUNG

- mm / inch
- N°1 ALBERO + DISTANZIALI
 - N°1 SHAFT + SPACER
 - N°1 DORN + ABSTANDSSTUECK

PER ALBERI E DISTANZIALI VEDI PAG. TBL250-1-00
FOR SHAFT END SPACER SEE PAGE TBL250-1-00
FUER DORN UND ABSTANDSSTUECK SEITE TBL250-1-00

Cod. MT	i	RPM max	Coppia Max Max Torque Max Drehmoment	Lubrificazione est. Ext. coolant Aussenkuehlung	D (mm)	D (Inch)	CHIAVI INCLUSE Keys included Schlüssel inbegriffen			
							CHUB30	CHESL08	CHESL10	CHUB24 (Ø16 / Ø3/4")
MSL0381100	1:1	6000	90Nm	X	16-22-27-32	3/4"-1"-1 1/4"	CHUB30	CHESL08	CHESL10	CHUB24 (Ø16 / Ø3/4")
MSL0382100	2:1	3000	110Nm	X	16-22-27-32	3/4"-1"-1 1/4"	CHUB30	CHESL08	CHESL10	CHUB24 (Ø16 / Ø3/4")

DMG-MORI

MOD: SL-ZL200/203/204/250/253/254(MC-SMC) SL2500Y DL-ZL200/250(MC)

MODULO MOTORIZZATO PORTACREATORE MAGGIORATO

Reinforced driven gear hobber

Angetriebenes Zahnradwaelzfraes-Werkzeug vergroessert

Subject to change without notice.

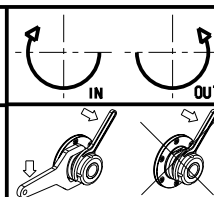

M.T. srl

Via Casino Albini 480
Tel. 0541/956034-957884
Fax 0541/956341

47842 S. GIOVANNI IN M. (RN)
e-mail: mtma@mtmarchetti.com
http://www.mtmarchetti.com



PAGINA MSL340-2-60

ATTENZIONE - ATTENTION - ACHTUNG

- VERIFICARE LE MISURE DI INGOMBRO PER POSSIBILE INTERFERENZA SU ALCUNI MODELLI DI MACCHINE
- Please check the overall sizes for possible interferences on some machine models
- Bitte überprüfen sie das ausmass um mögliche interferenzen auf einigen maschinen modellen zu vermeiden

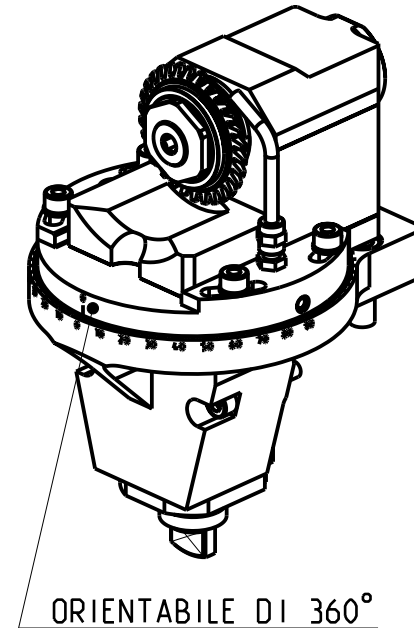
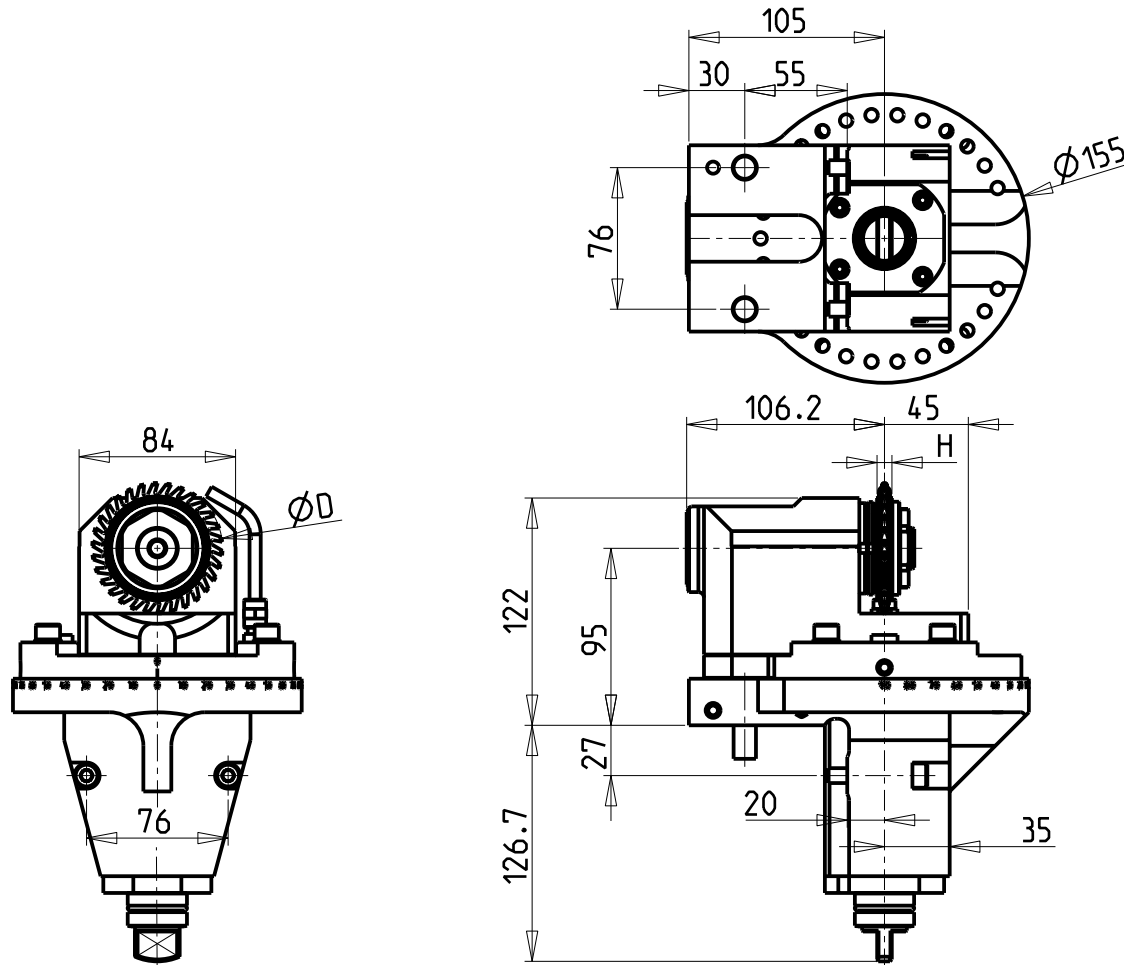

ORIENTABILE DI 360°

Cod. MT	Mandrino Spindle Spindel	I	RPM	Coppia Max Max Torque Max Drehmoment	Lubrificazione est. Ext. coolant Aussenkuehlung	ØD	H	CHIAVI INCLUSE Keys included Schluessel einbegriffen	
MSL0428022	Ø22x12	1:1	6000	50Nm	X	63-70-80	MAX 12	CHUB38	CHESLO8

DMG-MORI
 MOD: SL-ZL200/203/204/250/253/254(MC-SMC) SL2500Y DL-ZL200/250(MC)

MODULO MOTORIZZATO PER VITI SENZA FINE
 Driven tool for worm screws
 Angetriebenes werkzeug für schrauben ohne ende

Subject to change without notice.

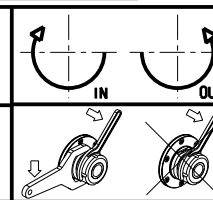

M.T. srl
 Via Casino Albini 480
 Tel. 0541/956034-957884
 Fax 0541/956341
 47842 S. GIOVANNI IN M. (RN)
 e-mail: mtma@mtmarchetti.com
 http://www.mtmarchetti.com



PAGINA MSL359-2-00

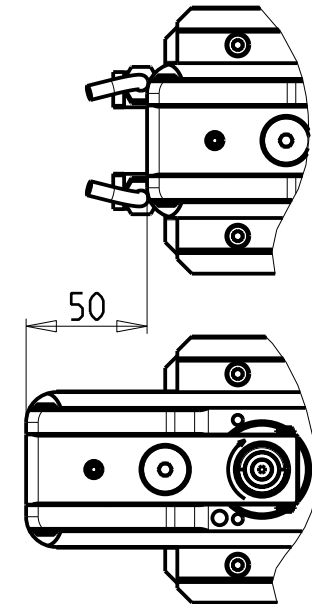
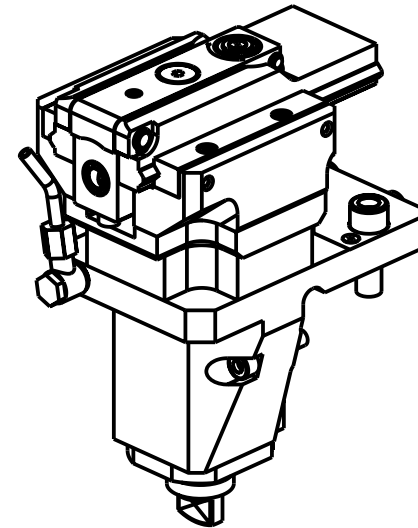
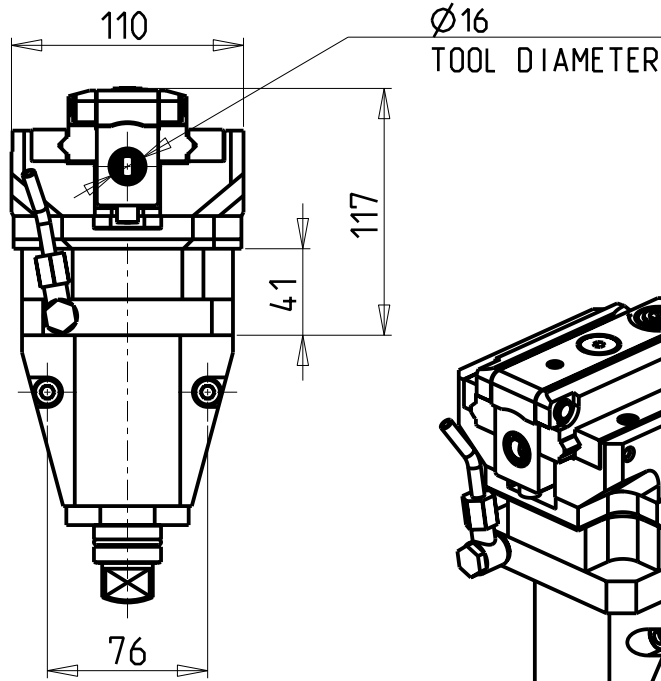
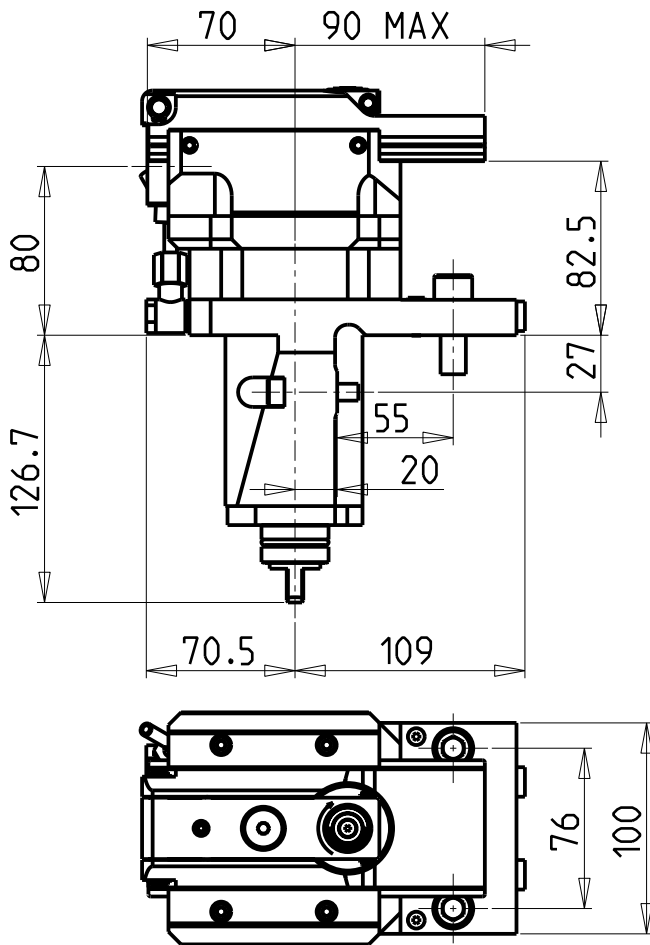

ATTENZIONE - ATTENTION - ACHTUNG

- VERIFICARE LE MISURE DI INGOMBRO PER POSSIBILE INTERFERENZA SU ALCUNI MODELLI DI MACCHINE
- Please check the overall sizes for possible interferences on some machine models
- Bitte überprüfen sie das ausmass um mögliche interferenzen auf einigen maschinen modellen zu vermeiden

DOTAZIONI - SUPPLIED WITH - AUSSTATTUNG

N*1 Boccola di riduz. Ø16-Ø12 e N*1 Boccola di riduz. Ø16-Ø10
 N*1 Reduction bush Ø16-Ø12 and N*1 Reduction bush Ø16-Ø10
 N*1 Reduzierbuchsen Ø16-Ø12 und N*1 Reduzierbuchsen Ø16-Ø10

PER UTENSILI STOZZATORI VEDI PAG. TBL400-1-00
 FOR DRIVEN SLOTTING TOOL CUTTING-TOOLS SEE PAGE TBL400-1-00
 FÜR NUTENSTOSS-WERKZEUG SCHNEIDWERKZEUGE SIEHE SEITE TBL400-1-00

Cod. MT	I	RPM MAX	Lubr. esterna Ext. coolant Aussenkuehlung
MSL0460100	4:1	2000	X

DMG-MORI
 MOD: SL-ZL200/203/204/250/253/254(MC-SMC) SL2500Y DL-ZL200/250(MC)

MODULO MOTORIZZATO STOZZATORE CORSA 50mm H=80mm
 Slotting driven tool 50mm stroke H=80mm
 Keilnutenstossmaschine 50mm Hub H=80mm

M.T. srl
 Via Casino Albini 480
 Tel. 0541/956034-957884
 Fax 0541/956341
 47842 S. GIOVANNI IN M. (RN)
 e-mail: mtma@mtmarchetti.com
 http://www.mtmarchetti.com



PAGINA MSL360-2-00

Subject to change without notice.

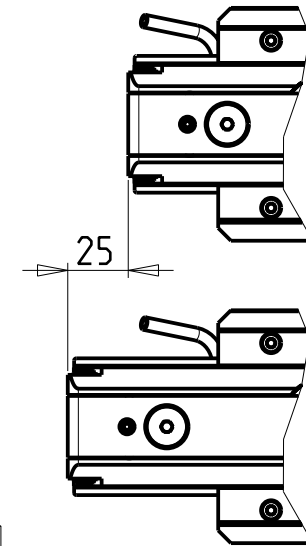
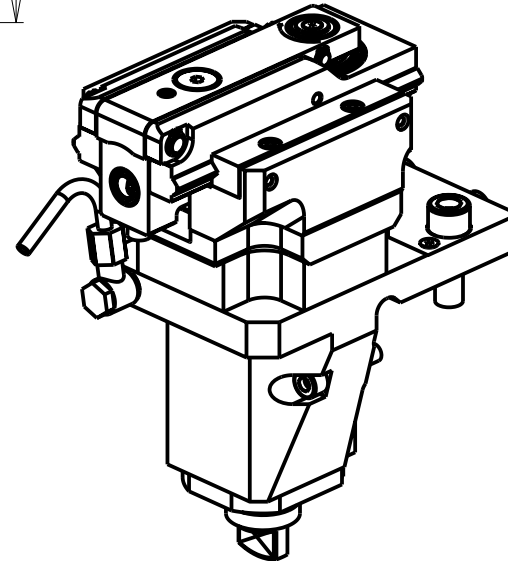
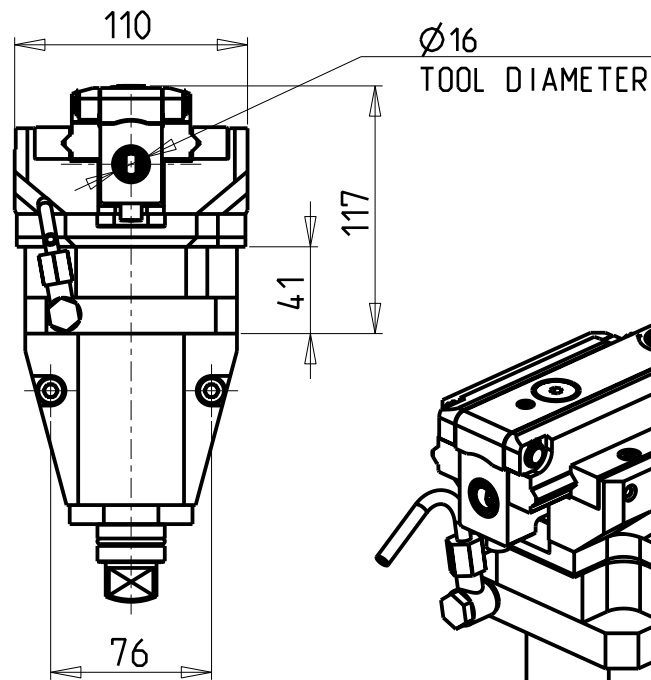
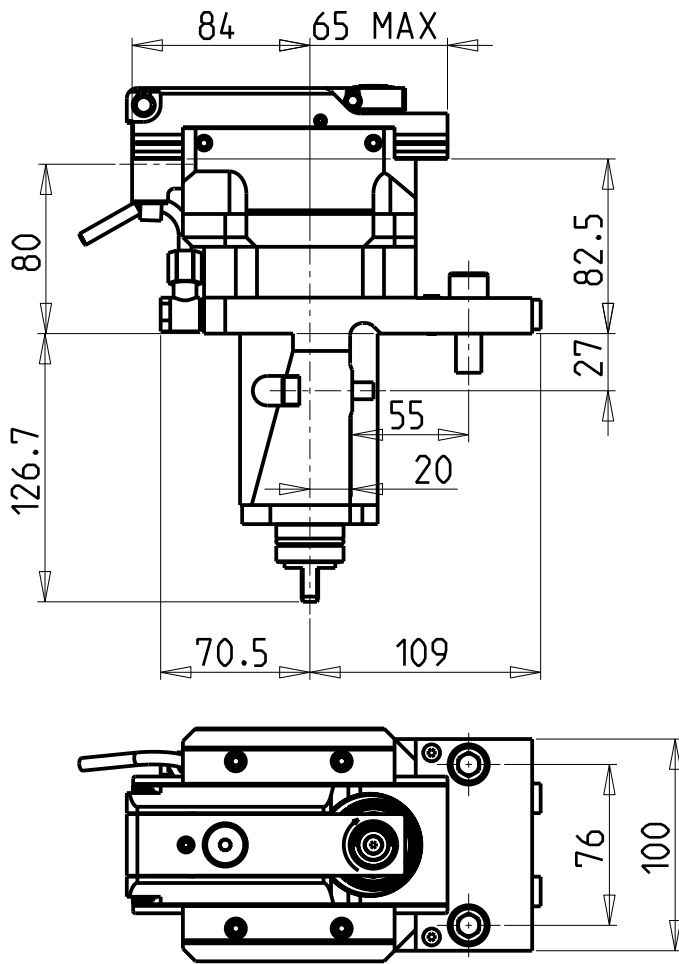

ATTENZIONE - ATTENTION - ACHTUNG

- VERIFICARE LE MISURE DI INGOMBRO PER POSSIBILE INTERFERENZA SU ALCUNI MODELLI DI MACCHINE
- Please check the overall sizes for possible interferences on some machine models
- Bitte überprüfen sie das ausmass um mögliche interferenzen auf einigen maschinen modellen zu vermeiden

DOTAZIONI - SUPPLIED WITH - AUSSTATTUNG

N°1 Boccola di riduz. Ø16-Ø12 e N°1 Boccola di riduz. Ø16-Ø10
 N°1 Reduction bush Ø16-Ø12 and N°1 Reduction bush Ø16-Ø10
 N°1 Reduzierbuchsen Ø16-Ø12 und N°1 Reduzierbuchsen Ø16-Ø10

PER UTENSILI STOZZATORI VEDI PAG. TBL400-1-00
 FOR DRIVEN SLOTTING TOOL CUTTING-TOOLS SEE PAGE TBL400-1-00
 FÜR NUTENSTOSS-WERKZEUG SCHNEIDWERKZEUGE SIEHE SEITE TBL400-1-00

Cod. MT	I	RPM MAX	Lubr. esterna Ext. coolant Aussenkuehlung
MSL0460200	4:1	2400	X

DMG-MORI

MOD: SL-ZL200/203/204/250/253/254(MC-SMC) SL2500Y DL-ZL200/250(MC)

MODULO MOTORIZZATO STOZZATORE CORSA 25mm H=80mm
 Slotting driven tool 25mm stroke H=80mm
 Keilnutenstossmaschine 25mm Hub H=80mm

M.T. srl

Via Casino Albini 480
 Tel. 0541/956034-957884
 Fax 0541/956341
 47842 S. GIOVANNI IN M. (RN)
 e-mail: mtma@mtmarchetti.com
 http://www.mtmarchetti.com



PAGINA MSL360-2-01

Subject to change without notice.

10/2021

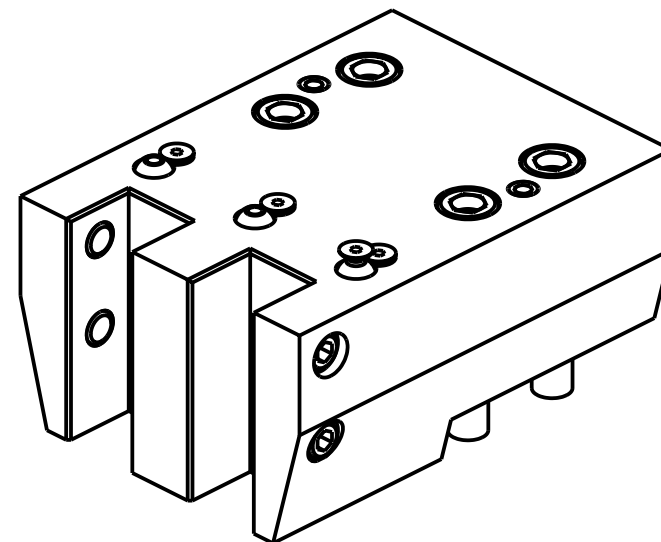
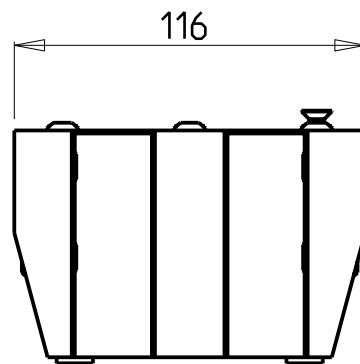
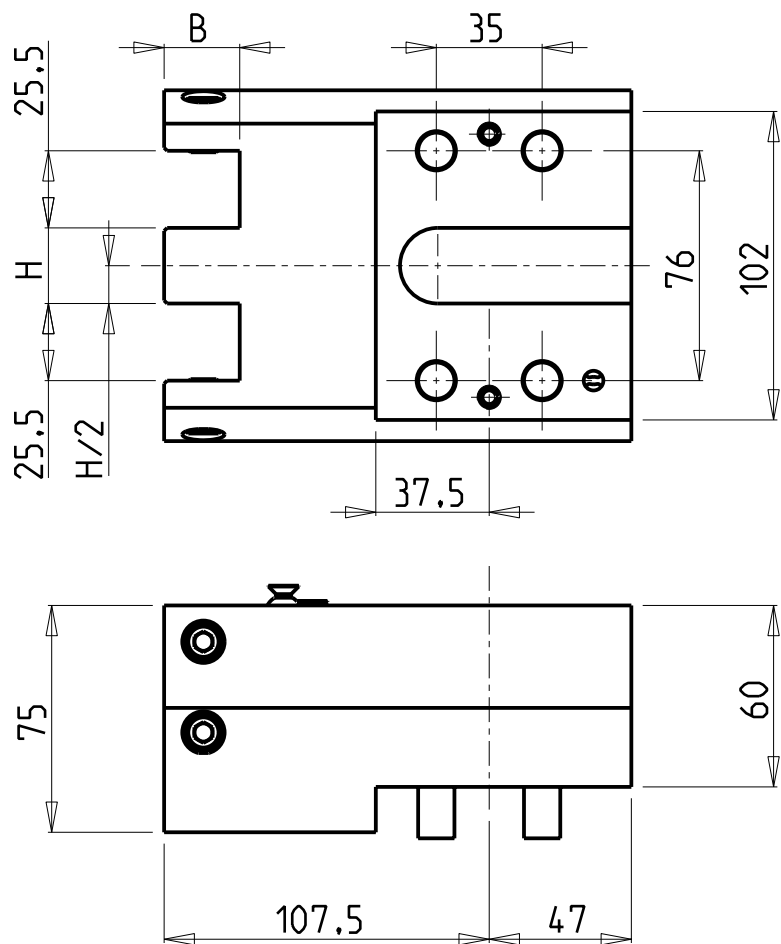

Cod. MT	Misure Dimensions Masse	H	B
MSL0342500	mm	25	25

DMG-MORI
MOD: SL2500Y

PORTAUTENSILE RADIALE SOVRAPPOSTO QD=25mm
Radial single side twin static tool QD=25mm
Radial Werkzeughalter ueberlagert QD=25mm

Subject to change without notice.

M.T. srl
Via Casino Albini 480
Tel. 0541/956034-957884
Fax 0541/956341
47842 S. GIOVANNI IN M. (RN)
e-mail: mtma@mtmarchetti.com
<http://www.mtmarchetti.com>



PAGINA MSL440-2-00

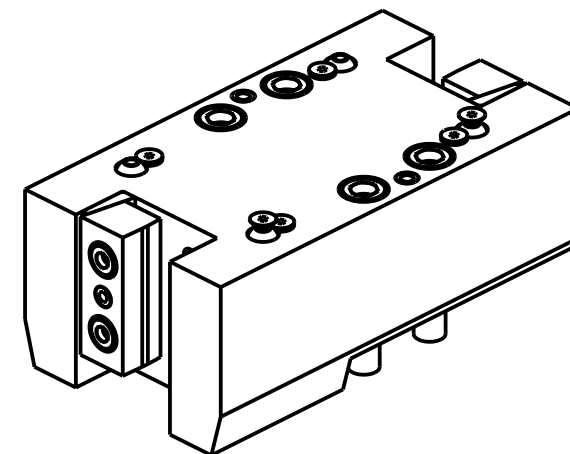
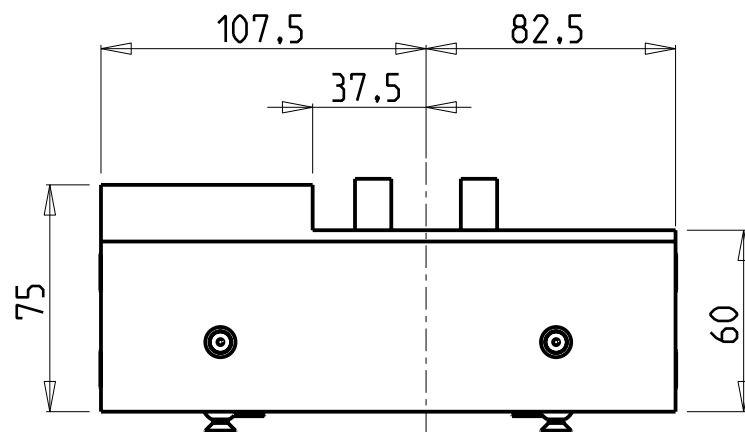
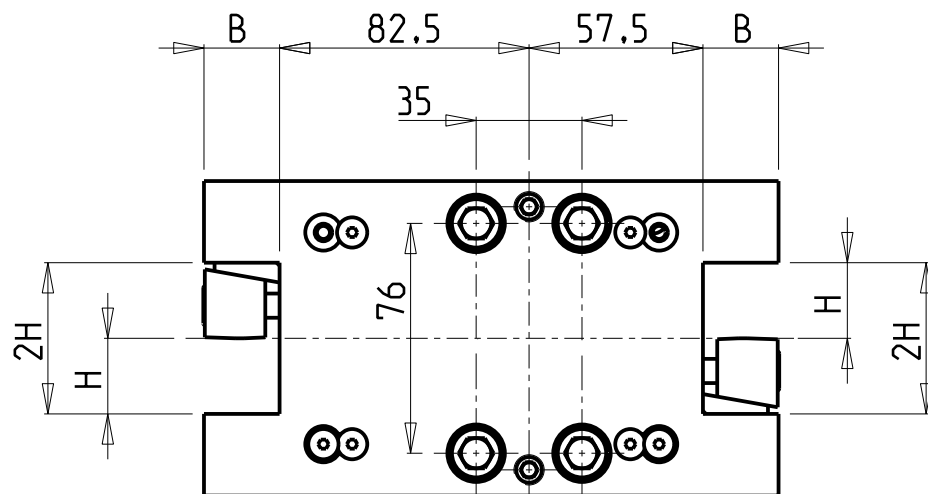
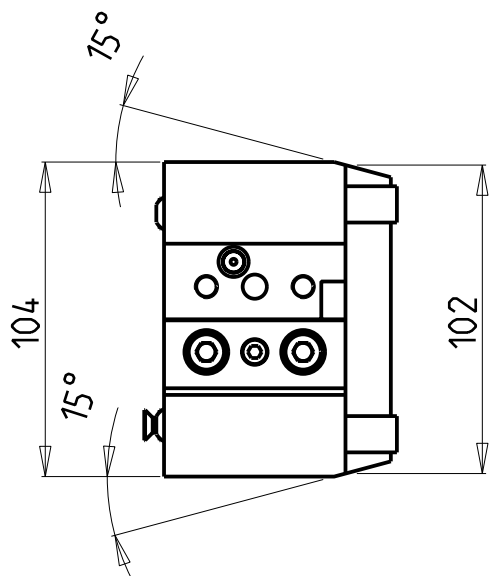

Cod. MT	N°Utensili N°Tools N°Werkzeuge	Misure Dimensions Masse	B	H
MSL0392500	2	mm	25	25
MSL0392540	2	Inch	1"	1"

NEW

DMG-MORI

MOD: SL-ZL200/203/204/250/253/254(MC-SMC) SL2500Y DL-ZL200/250(MC)

PORTAUTENSILE RADIALE DOPPIO QD=25mm / QD=1"

Radial double static tool QD=25mm / QD=1"

Radial Doppel-Werkzeughalter QD=25mm / QD=1"

Subject to change without notice.

M.T. srl

Via Casino Albini 480
Tel. 0541/956034-957884
Fax 0541/956341

47842 S. GIOVANNI IN M. (RN)
e-mail: mtma@mtmarchetti.com
http://www.mtmarchetti.com



PAGINA MSL453-2-00

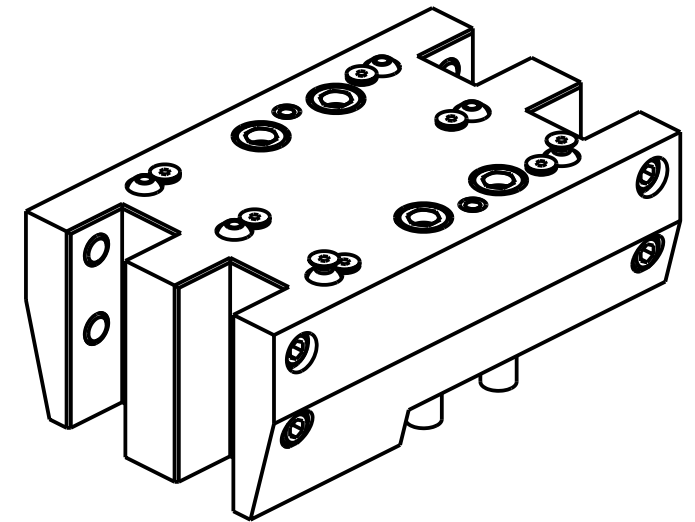
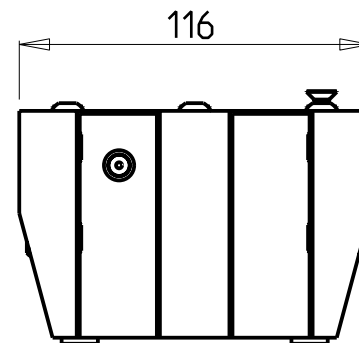
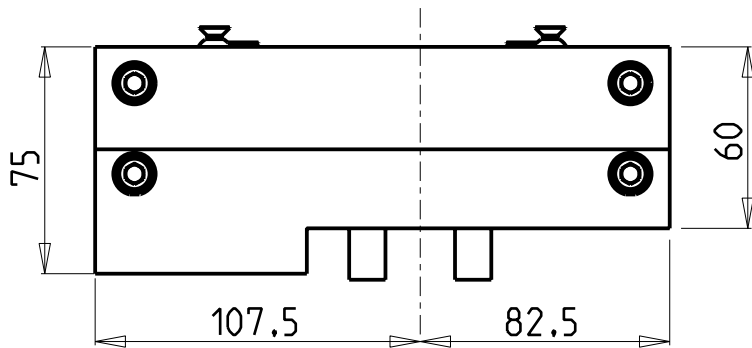
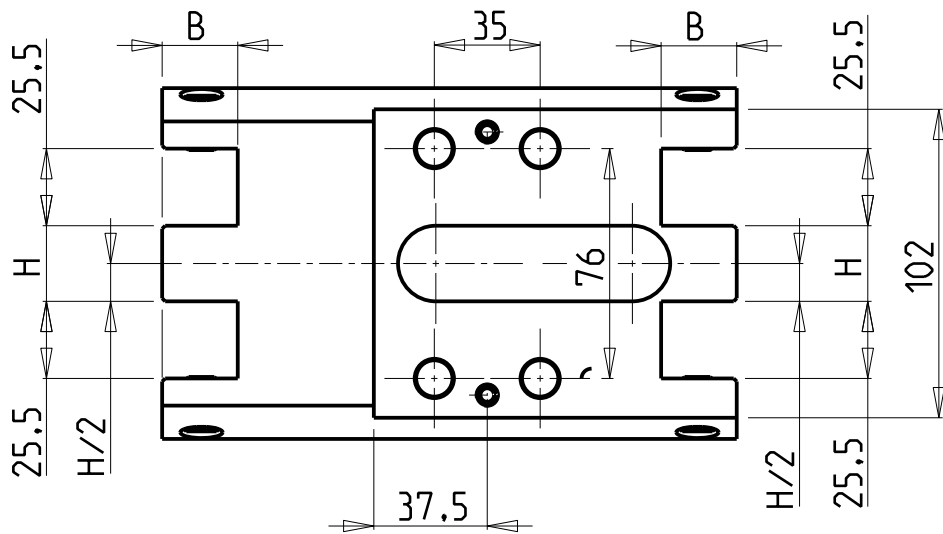

Cod. MT	Misure Dimensions Masse	H	B
MSL0332500	mm	25	25

DMG-MORI
MOD: SL2500YS

PORTAUTENSILE RADIALE DOPPIO SOVRAPPOSTO QD=25mm
Radial double side twin static tool QD=25mm
Radial Doppel-Werkzeughalter ueberlagert QD=25mm

Subject to change without notice.

M.T. srl
Via Casino Albini 480
Tel. 0541/956034-957884
Fax 0541/956341
47842 S. GIOVANNI IN M. (RN)
e-mail: mtma@mtmarchetti.com
<http://www.mtmarchetti.com>



PAGINA MSL460-2-00

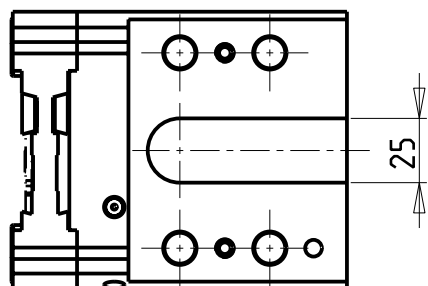
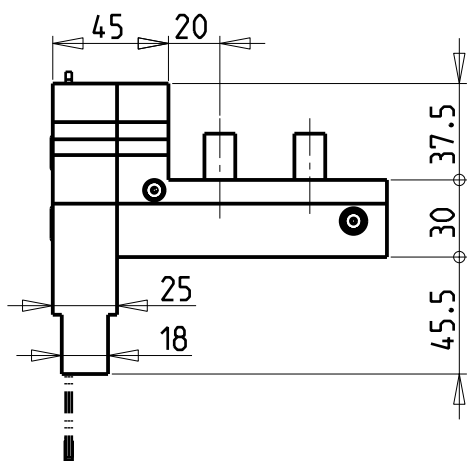
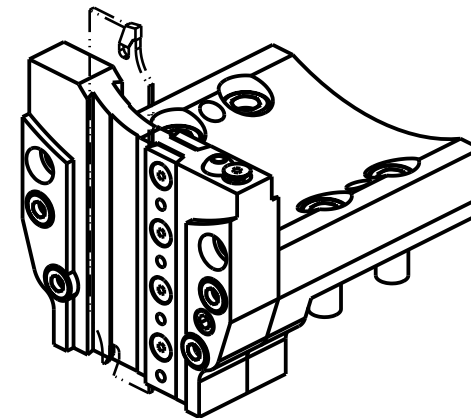
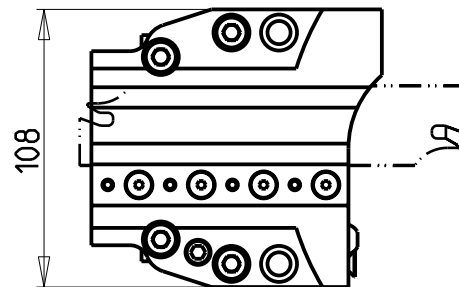
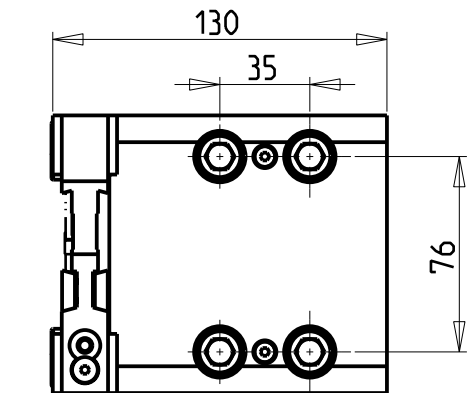
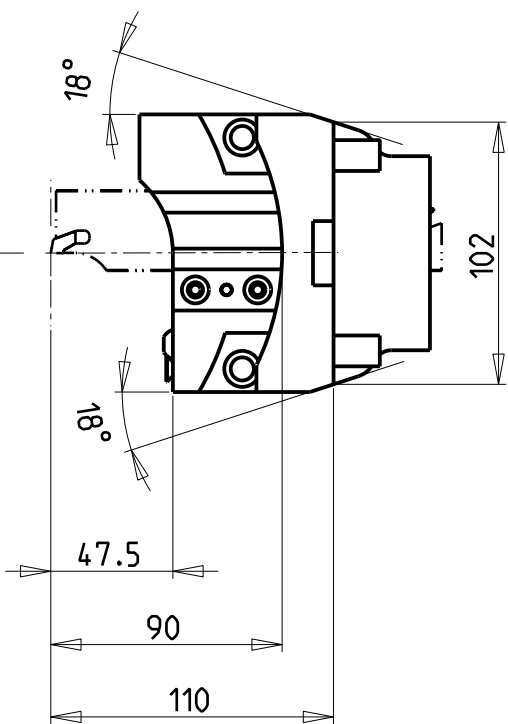

POSSIBILITA' DI LAVORO M3/M4
 OPTION OF M3/M4 WORKING
 ARBEITSMÖGLICHKEIT M3/M4

DOTAZIONI - SUPPLIED WITH - AUSSTATTUNG

- N°1 - LAMA - BLADE - KLINGE ISCAR H=32 Sp. 3/4mm (KENNAMETAL OPTIONAL)
- N°10 - INSERTI - INSERTS - EINLAGEN
- N°1 - CHIAVE A T PER MONTAGGIO INSERTI
 - T-WRENCH FOR INSERT SET UP
 - T-SCHLUESSEL FUER EINSATZSTUECK-MONTAGE

Cod. MT	N°Utensili N° Tools N° Werkzeuge	Lubr.esterna Ext. coolant Aussenkuehlung
MSL0530132	1	X

DMG-MORI
 MOD: SL-ZL200/203/204/250/253/254(MC-SMC) SL2500Y DL-ZL200/250(MC)

PORTAUTENSILE PER LAMA DOPPIO
 Radial double blade holder
 Radial Doppel-Abstechhalter

Subject to change without notice.

M.T. srl
 Via Casino Albini 480
 Tel. 0541/956034-957884
 Fax 0541/956341
 47842 S. GIOVANNI IN M. (RN)
 e-mail: mtma@mtmarchetti.com
 http://www.mtmarchetti.com



PAGINA MSL520-2-00

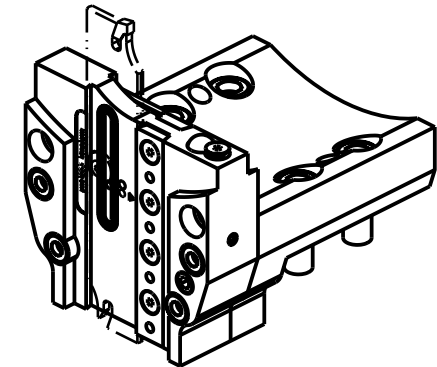
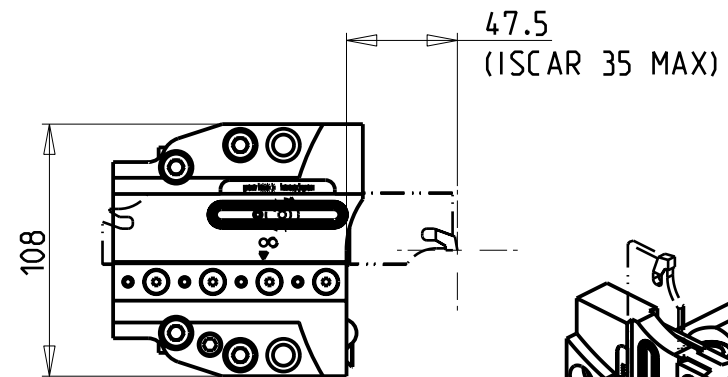
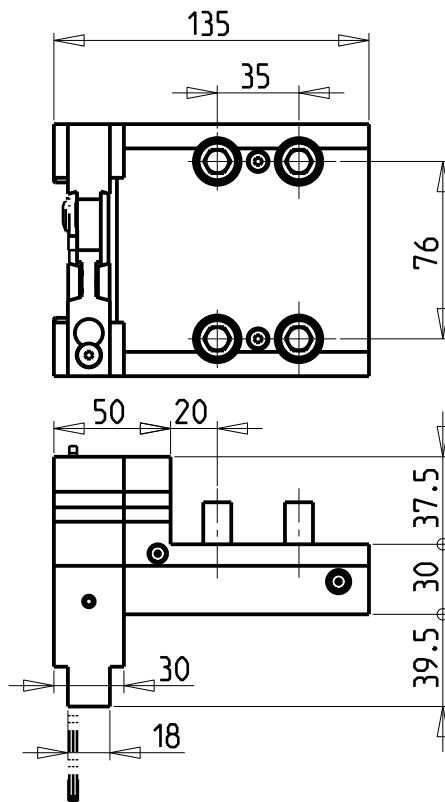
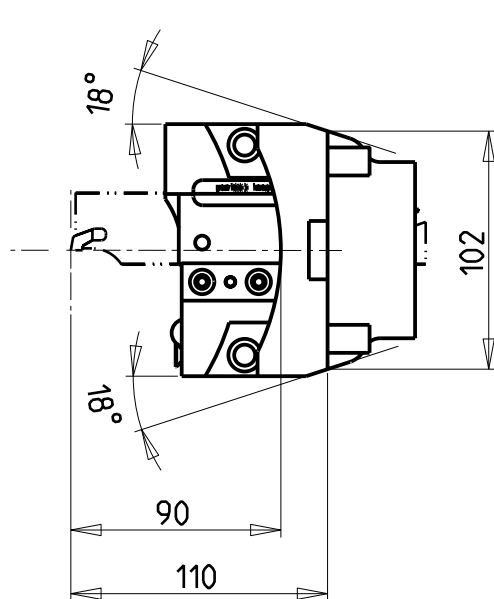

POSSIBILITA' DI LAVORO M3/M4
 OPTION OF M3/M4 WORKING
 ARBEITSMÖGLICHKEIT M3/M4

KIT LAME NON INCLUSI (OPZIONALI)
BLADES NOT SUPPLIED WITH (OPTIONAL)
KLINGEN NICHT INBEGRIFFEN (OPTIONAL)

- LAMA-BLADE-KLINGE SANDVIK H=32 sp.3 cod. QD_NN2G60C 25A
 +INSERTI-INSERTS-EINLAGEN cod. QD_NG_0300_0002_CM_1145 (10 pz.)
- LAMA-BLADE-KLINGE SANDVIK H=32 sp.4 cod. QD_NN2H60C 25A
 +INSERTI-INSERTS-EINLAGEN cod. QD_NH_0400_0002_CM_1145 (10 pz.)
- LAMA-BLADE-KLINGE ISCAR H=32 sp.3 cod. SGFH_32K_3
 +INSERTI-INSERTS-EINLAGEN cod. 6011365 (10pz.)
- LAMA-BLADE-KLINGE ISCAR H=32 sp.4 cod. SGFH_32K_4
 +INSERTI-INSERTS-EINLAGEN cod. 6011366 (10pz.)
- LAMA-BLADE-KLINGE WALTER H=32 sp.3 cod. G2042.32N-3T45SX-P
 +INSERTI-INSERTS-EINLAGEN cod. SX-3E300N02-CE4 WSM33S (10pz.) + CHIAVE-KEY cod. FS1494
- LAMA-BLADE-KLINGE WALTER H=32 sp.4 cod. G2042.32N-4T50SX-P
 +INSERTI-INSERTS-EINLAGEN cod. SX-4E400N02-CE4 WSM33S (10pz.) + CHIAVE-KEY cod. FS1494

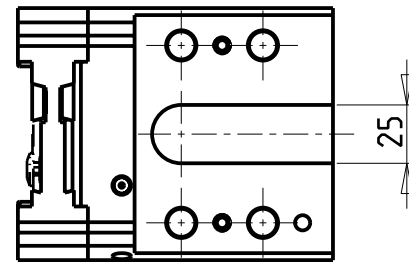

Cod. MT	N°Utensili N°Tools N°Werkzeuge	Lubr.esterna Ext. coolant Aussenkuehlung	Lubr.interna Coolant through Innenkuehlung
MSL0540132	1	X	P=70bar

DMG-MORI
 MOD: SL-ZL200/203/204/250/253/254(MC-SMC) SL2500Y DL-ZL200/250(MC)

PORTAUTENSILE PER LAMA DOPPIO CON LUBRIFICAZIONE INTERNA
 Radial double blade holder with internal coolant
 Radial Doppel-Abstechhalter mit Innenkuehlung

Subject to change without notice.

M.T. srl
 Via Casino Albini 480
 Tel. 0541/956034-957884
 Fax 0541/956341
 47842 S. GIOVANNI IN M. (RN)
 e-mail: mtma@mtmarchetti.com
 http://www.mtmarchetti.com



PAGINA MSL520-2-04

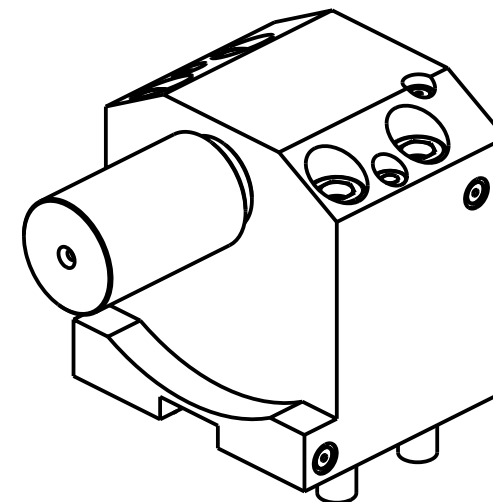
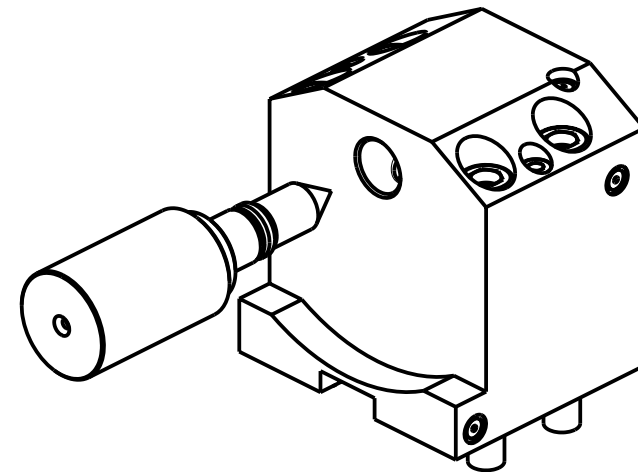
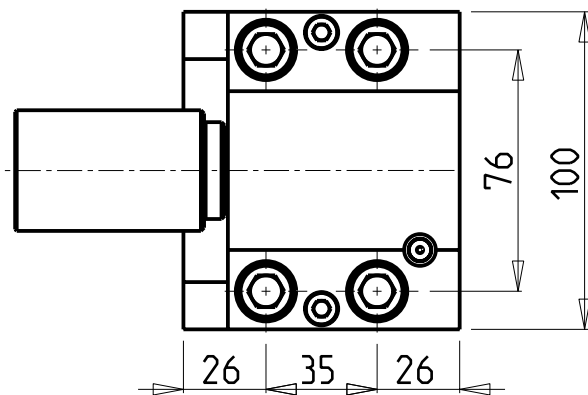
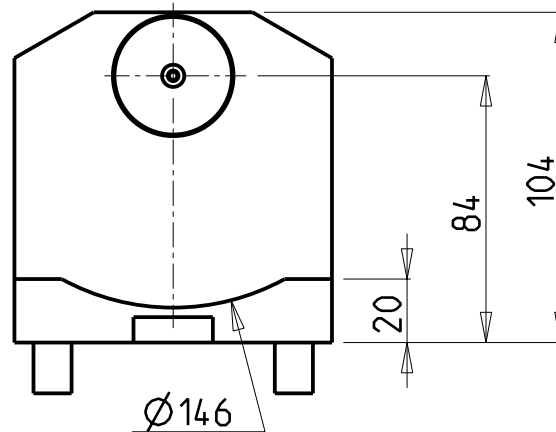
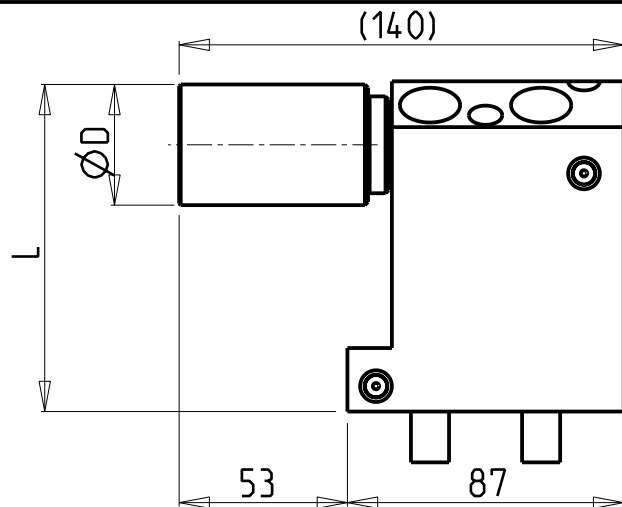

Cod. MT	N° Utensili N° Tools N° Werkzeuge	D	L
MSL0280100	1	38	103
MSL0280100L	1	2"	109.4

DMG-MORI
 MOD: SL-ZL200/203/204/250/253/254 SMC - SL2500Y

CONTROPUNTA PER CONTROMANDRINO
 Tailstock for subspindle
 Gegenspintz fuer Gegenspindel

Subject to change without notice.

M.T. srl
 Via Casino Albini 480
 Tel. 0541/956034-957884
 Fax 0541/956341
 47842 S. GIOVANNI IN M. (RN)
 e-mail: mtma@mtmarchetti.com
 http://www.mtmarchetti.com



PAGINA MSL950-2-00

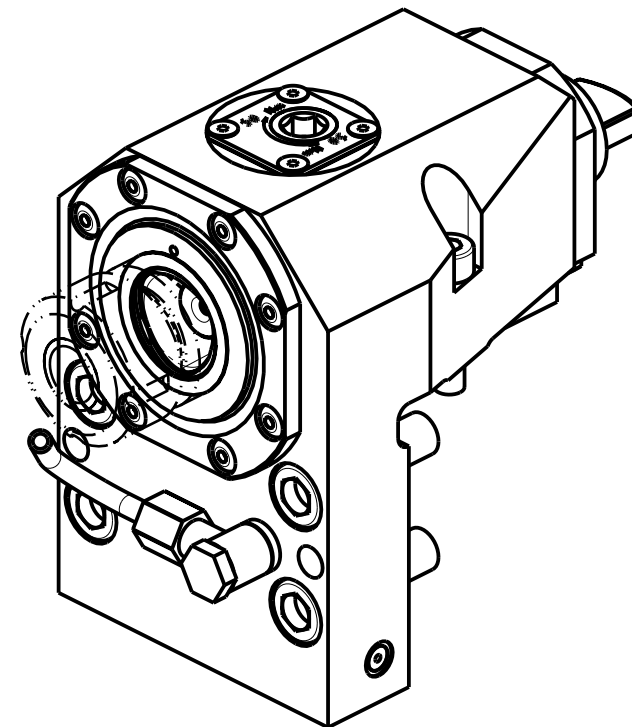
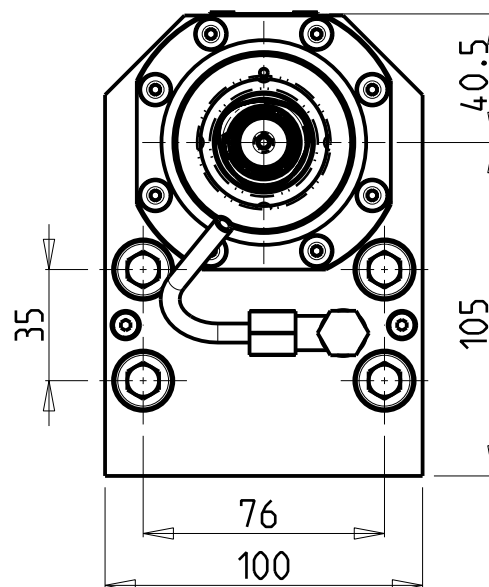
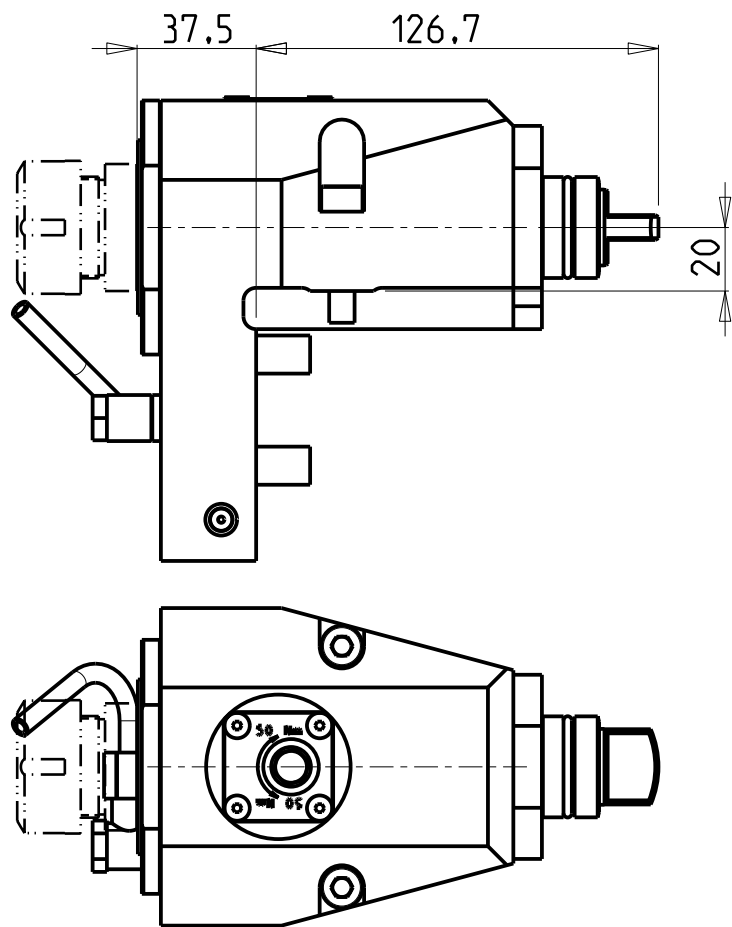

Cod. MT	TAGLIA Size Masse	I	RPM	Coppia Max Max Torque Max Drehmoment	Lubrificazione int. Coolant through Innenkuehlung	Lubrificazione est. Ext. coolant Aussenkuehlung
MSL0060140	C4	1:1	6000	70Nm	-	X
MSL0060240	C4	1:1	6000	70Nm	P=70bar	X

DMG-MORI

MOD: SL-ZL200/203/204/250/253/254(MC-SMC) SL2500Y DL-ZL200/250(MC)

MODULO MOTORIZZATO RADIALE MT CAPTO

Radial driven tool MT CAPTO

Radial angetriebenes Werkzeug MT CAPTO

Subject to change without notice.

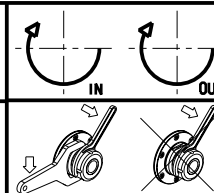

M.T. srl

Via Casino Albini 480
Tel. 0541/956034-957884
Fax 0541/956341

47842 S. GIOVANNI IN M. (RN)
e-mail: mtma@mtmarchetti.com
http://www.mtmarchetti.com



PAGINA MSL010-B-40

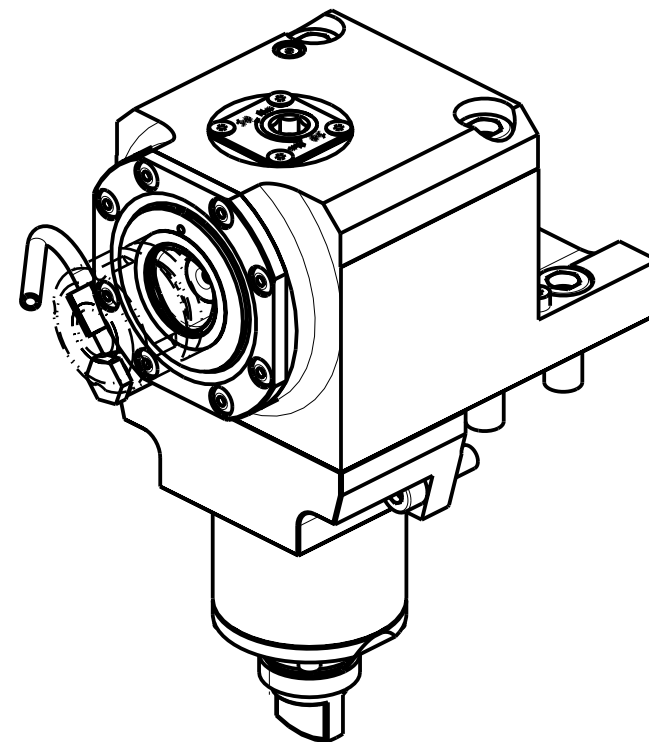
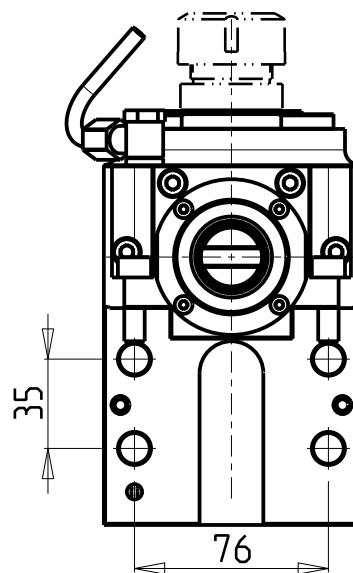
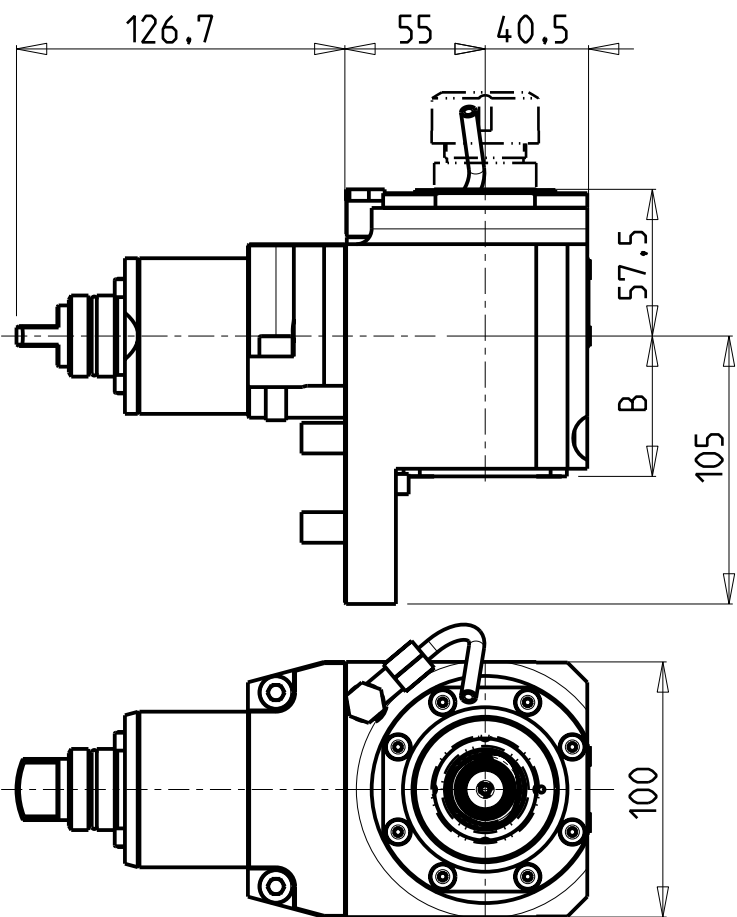

Cod. MT	TAGLIA Size Masse	I	RPM	Coppia Max Max Torque Max Drehmoment	Lubr.interna Coolant through Innenkuehlung	Lubr.esterna Ext. coolant Aussenkuehlung	B
MSL0050140	C4	1:1	6000	70Nm		X	55
MSL0050240	C4	1:1	6000	70Nm	P=70bar	X	67.5

DMG-MORI

MOD: SL-ZL200/203/204/250/253/254(MC-SMC) SL2500Y DL-ZL200/250(MC)

MODULO MOTORIZZATO ASSIALE MT CAPTO

Axial driven tool MT CAPTO

Axial angetriebenes Werkzeug MT CAPTO

Subject to change without notice.

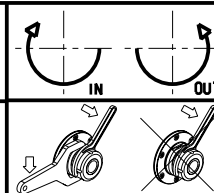

M.T. srl

Via Casino Albini 480
Tel. 0541/956034-957884
Fax 0541/956341

47842 S. GIOVANNI IN M. (RN)
e-mail: mtma@mtmarchetti.com
http://www.mtmarchetti.com



PAGINA MSL150-B-40

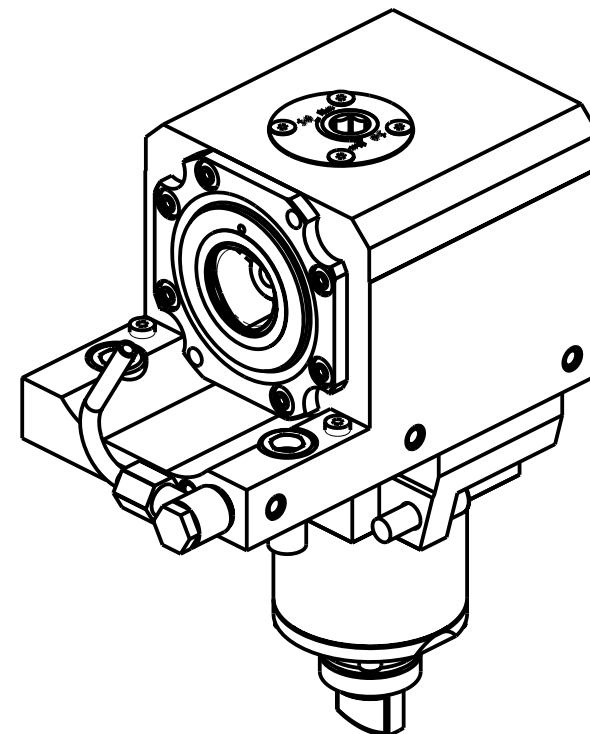
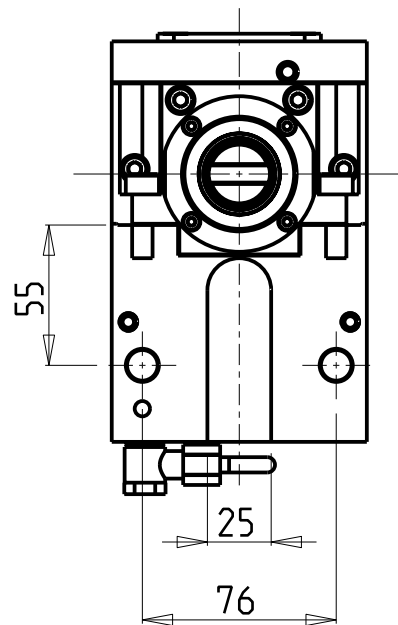
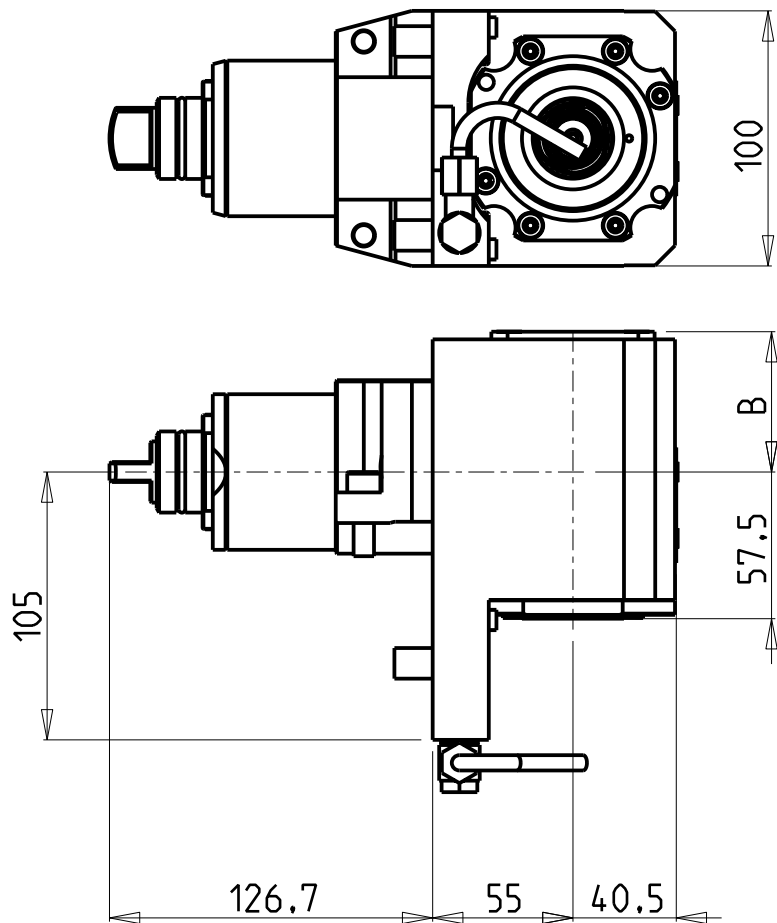

Cod. MT	TAGLIA Size Masse	I	RPM	Coppia Max Max Torque Max Drehmoment	Lubr.interna Coolant through Innenkuehlung	Lubr.esterna Ext. coolant Aussenkuehlung	B
MSL0590140	C4	1:1	6000	70Nm	-	X	55
MSL0590240	C4	1:1	6000	70Nm	P=70bar	X	67.5

DMG-MORI

MOD: SL-ZL200/203/204/250/253/254(MC-SMC) SL2500Y DL-ZL200/250(MC)

MODULO MOTORIZZATO ASSIALE PER CONTROMANDRINO MT CAPTO

Axial driven tool for subspindle MT CAPTO

Axial angetriebenes Werkzeug fuer Gegenspindel MT CAPTO

Subject to change without notice.

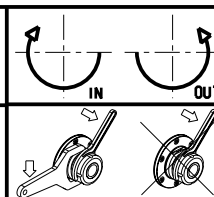

M.T. srl

Via Casino Albini 480
Tel. 0541/956034-957884
Fax 0541/956341

47842 S. GIOVANNI IN M. (RN)
e-mail: mtma@mtmarchetti.com
http://www.mtmarchetti.com



PAGINA MSL155-B-40

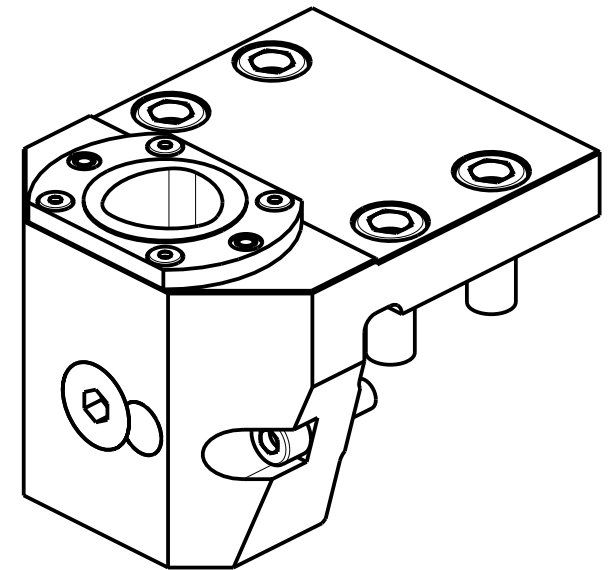
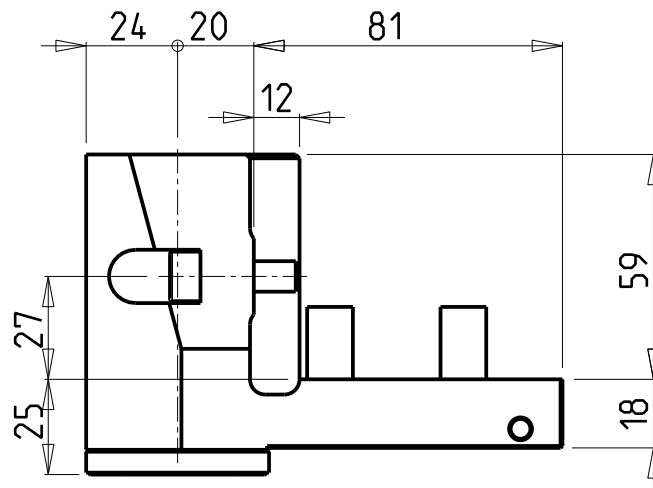
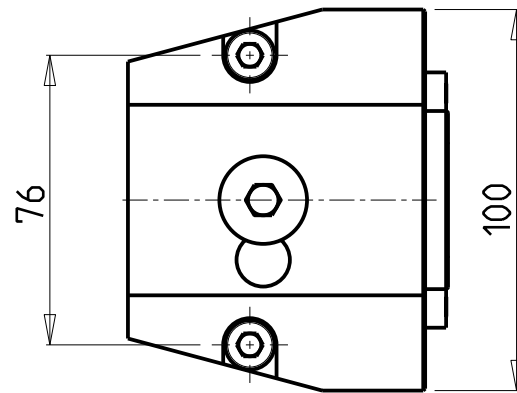
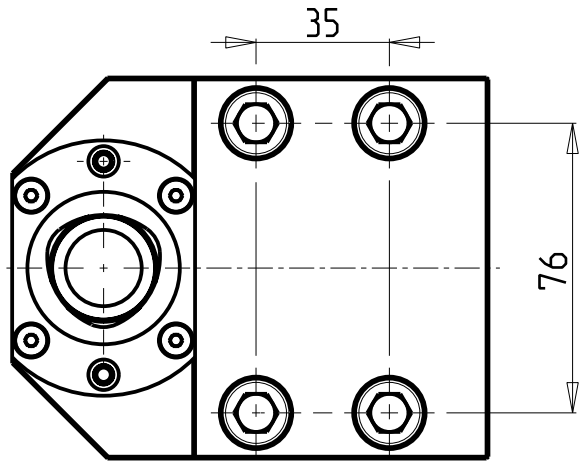

VERSIONE DESTRA (RC)
RIGHT VERSION (RC)
RECHTE-VERSION (RC)



VERSIONE SINISTRA (LC)
LEFT VERSION (LC)
LINKE-VERSION (LC)



PER ORDINARE LA VERSIONE SX
AGGIUNGERE "LC" AL CODICE IN TABELLA.
ES: MNL0464010 DIVENTA MNL0464010LC

TO ORDER LEFT VERSION
ADD A "LC" IN THE CODE-CHARTS.
EXAMPLE: MNL0464010 BECOMES MNL0464010LC

UM DIE LINKE-VERSION ZU BESTELLEN, BEI DER
ARTIKELBEZEICHNUNG "LC" HINZUFUEGEN.
BEISPIEL: MNL0464010 WIRD DANN MNL0464010LC

Cod. MT	N°Utensili N°Tools N°Werkzeuge	Lubrificazione int. Coolant through Innenkuehlung	TAGLIA Size Masse
MSL0044010	1	X	C4

DMG-MORI
MOD: SL-ZL200/203/204/250/253/254(MC-SMC) SL2500Y DL-ZL200/250(MC)

PORTAUTENSILE RADIALE SINGOLO ARRETRATO MT CAPTO
Radial single rear-set static tool MT CAPTO
Radial Single-Werkzeughalter zurueckversetzt MT CAPTO

M.T. srl
Via Casino Albini 480
Tel. 0541/956034-957884
Fax 0541/956341
47842 S. GIOVANNI IN M. (RN)
e-mail: mtma@mtmarchetti.com
http://www.mtmarchetti.com



PAGINA MSL430-B-40

Subject to change without notice.

10/2021

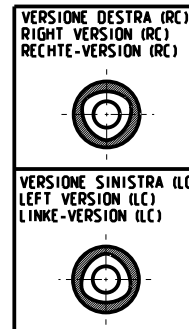
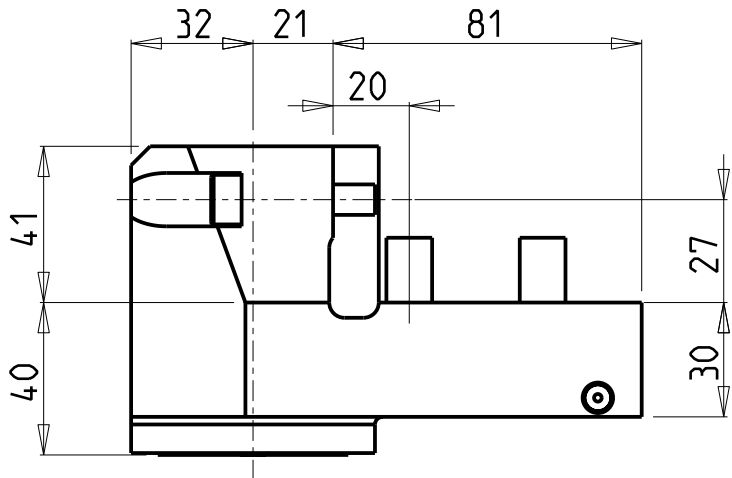
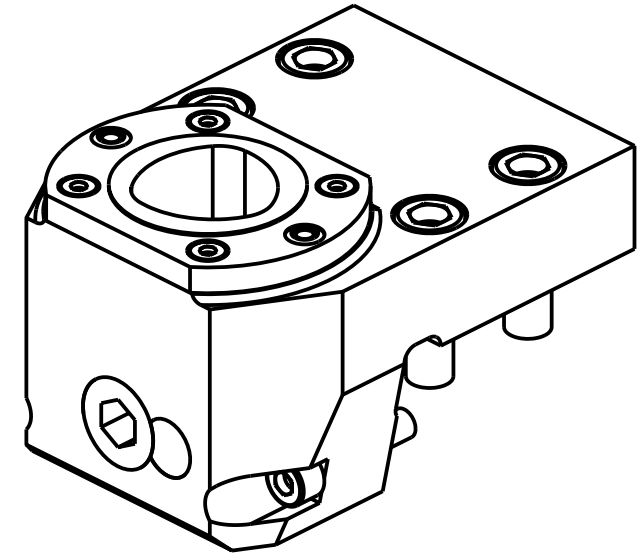
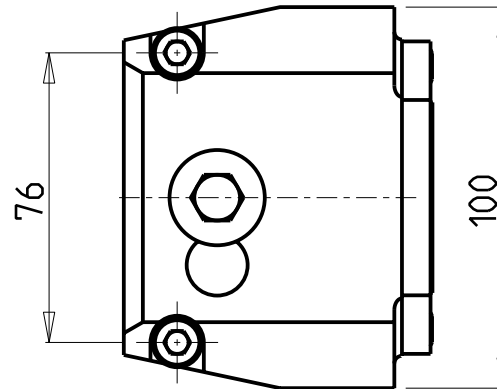
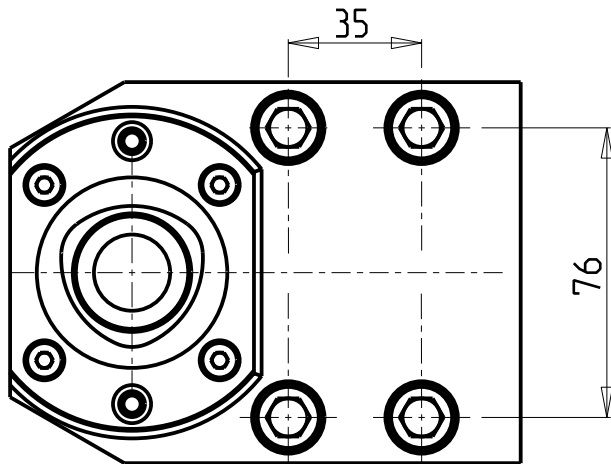

PER ORDINARE LA VERSIONE SX
 AGGIUNGERE "LC" AL CODICE IN TABELLA.
 ES: MSL0045010 DIVENTA MSL0045010LC

TO ORDER LEFT VERSION
 ADD A "LC" IN THE CODE-CHARTS.
 EXAMPLE: MSL0045010 BECOMES MSL0045010LC

UM DIE LINKE-VERSION ZU BESTELLEN, BEI DER
 ARTIKELBEZEICHNUNG "LC" HINZUFUEGEN.
 BEISPIEL: MSL0045010 WIRD DANN MSL0045010LC

Cod. MT	N°Utensili N°Tools N°Werkzeuge	Lubrificazione int. Coolant through Innenkuehlung	TAGLIA Size Masse
MSL0045010	1	X	C5

DMG-MORI
 MOD: SL-ZL200/203/204/250/253/254(MC-SMC) SL2500Y DL-ZL200/250(MC)

PORTAUTENSILE RADIALE SINGOLO ARRETRATO MT CAPTO
 Radial single rear-set static tool MT CAPTO
 Radial Single-Werkzeughalter zurueckversetzt MT CAPTO

M.T. srl
 Via Casino Albini 480
 Tel. 0541/956034-957884
 Fax 0541/956341
 47842 S. GIOVANNI IN M. (RN)
 e-mail: mtma@mtmarchetti.com
 http://www.mtmarchetti.com



PAGINA MSL430-B-50

Subject to change without notice.

10/2021

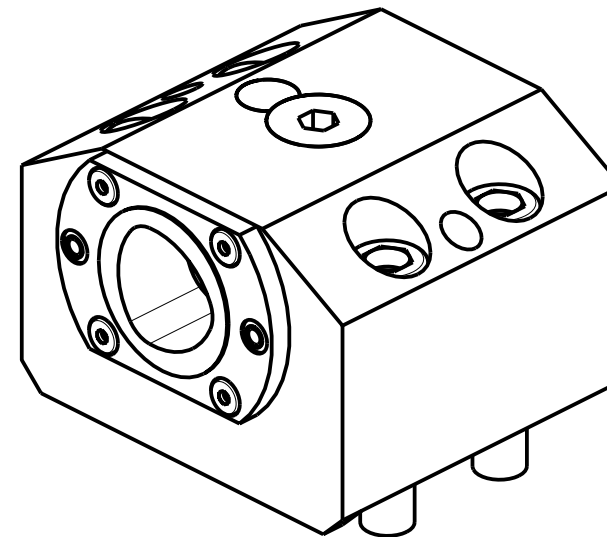
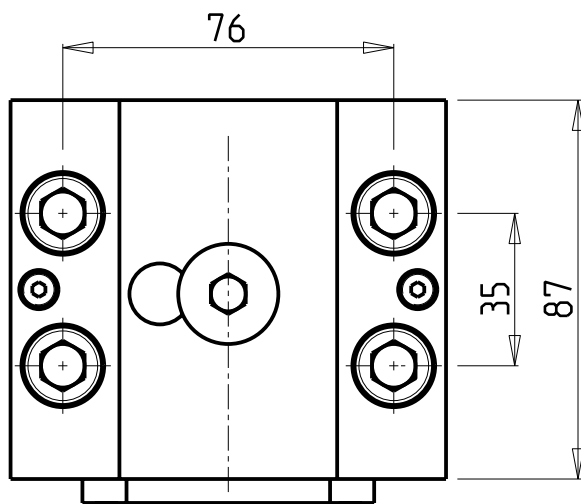
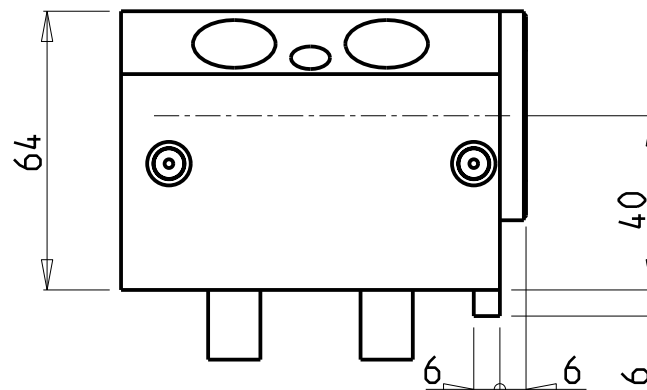
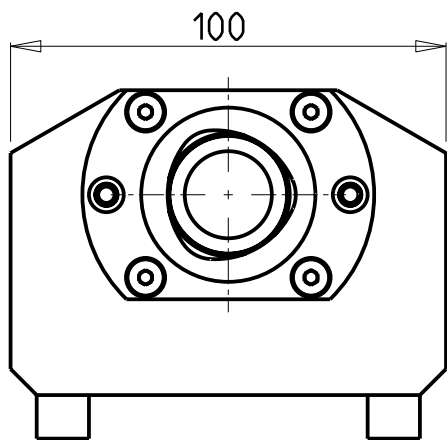

VERSIONE DESTRA (RC)
RIGHT VERSION (RC)
RECHTE-VERSION (RC)



VERSIONE SINISTRA (LC)
LEFT VERSION (LC)
LINKE-VERSION (LC)



PER ORDINARE LA VERSIONE SX
AGGIUNGERE "LC" AL CODICE IN TABELLA.
ES: MNL0464010 DIVENTA MNL0464010LC

TO ORDER LEFT VERSION
ADD A "LC" IN THE CODE-CHARTS.
EXAMPLE: MNL0464010 BECOMES MNL0464010LC

UM DIE LINKE-VERSION ZU BESTELLEN, BEI DER
ARTIKELBEZEICHNUNG "LC" HINZUFUEGEN.
BEISPIEL: MNL0464010 WIRD DANN MNL0464010LC

Cod. MT	N°Utensili N°Tools N°Werkzeuge	Lubrificazione int. Coolant through Innenkuehlung	TAGLIA Size Masse
MSL0034010	1	X	C4

DMG-MORI
MOD: SL-ZL200/203/204/250/253/254(MC-SMC) SL2500Y DL-ZL200/250(MC)

PORTAUTENSILE ASSIALE SINGOLO MT CAPTO
Axial single static tool MT CAPTO
Axial Single-Werkzeughalter MT CAPTO

M.T. srl
Via Casino Albini 480
Tel. 0541/956034-957884
Fax 0541/956341
47842 S. GIOVANNI IN M. (RN)
e-mail: mtma@mtmarchetti.com
http://www.mtmarchetti.com



PAGINA MSL550-B-40

Subject to change without notice.

10/2021

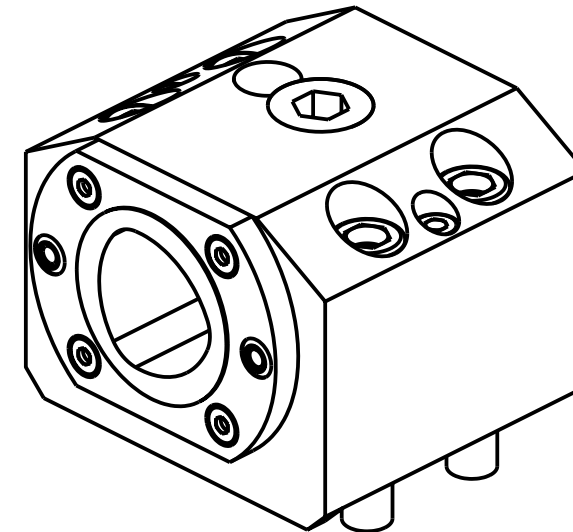
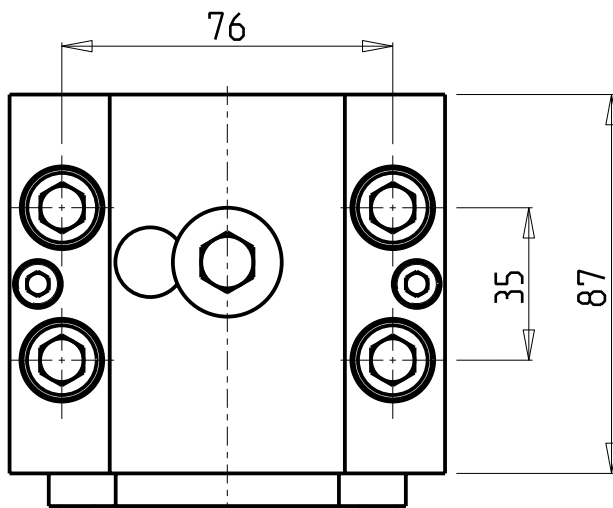
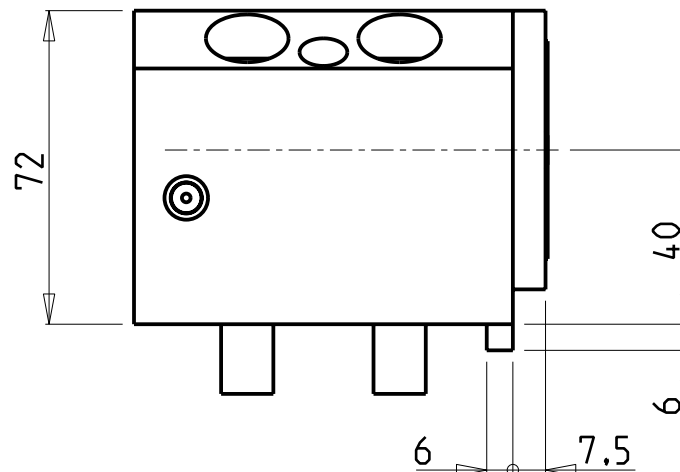
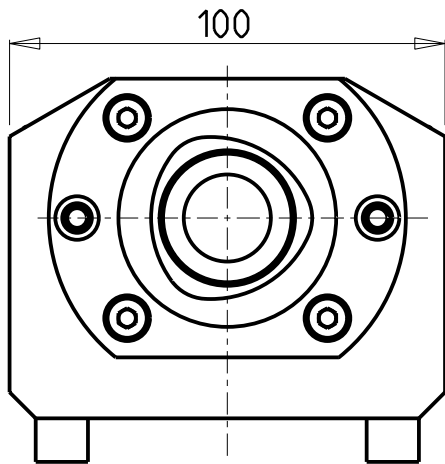

VERSIONE DESTRA (RC)
RIGHT VERSION (RC)
RECHTE-VERSION (RC)



VERSIONE SINISTRA (LC)
LEFT VERSION (LC)
LINKE-VERSION (LC)



PER ORDINARE LA VERSIONE SX
AGGIUNGERE "LC" AL CODICE IN TABELLA.
ES: MSL0035010 DIVENTA MSL0035010LC

TO ORDER LEFT VERSION
ADD A "LC" IN THE CODE-CHARTS.
EXAMPLE: MSL0035010 BECOMES MSL0035010LC

UM DIE LINKE-VERSION ZU BESTELLEN, BEI DER
ARTIKELBEZEICHNUNG "LC" HINZUFUEGEN.
BEISPIEL: MSL0035010 WIRD DANN MSL0035010LC

Cod. MT	N°utensili N°Tools N°Werkzeuge	Lubrificazione int. Coolant through Innenkuehlung	TAGLIA Size Masse
MSL0035010	1	X	C5

DMG-MORI

MOD: SL-ZL200/203/204/250/253/254(MC-SMC) SL2500Y DL-ZL200/250(MC)

PORTAUTENSILE ASSIALE SINGOLO MT CAPTO

Axial single static tool MT CAPTO

Axial Single-Werkzeughalter MT CAPTO

Subject to change without notice.

M.T. srl

Via Casino Albini 480
Tel. 0541/956034-957884
Fax 0541/956341
47842 S. GIOVANNI IN M. (RN)
e-mail: mtma@mtmarchetti.com
http://www.mtmarchetti.com



PAGINA MSL550-B-50

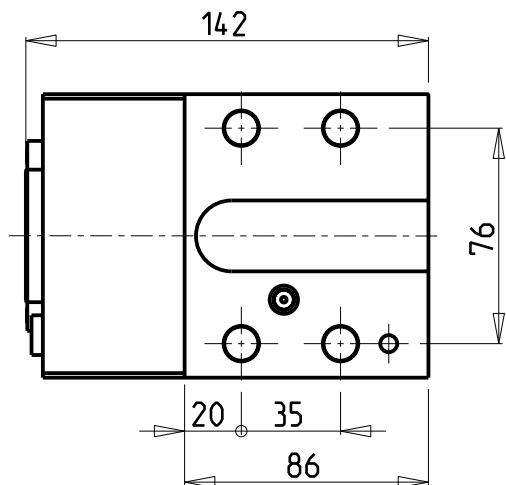

VERSIONE DESTRA (RC)
RIGHT VERSION (RC)
RECHTE-VERSION (RC)



VERSIONE SINISTRA (LC)
LEFT VERSION (LC)
LINKE-VERSION (LC)



**PER ORDINARE LA VERSIONE SX
AGGIUNGERE "LC" AL CODICE IN TABELLA.
ES: MSL0564020 DIVENTA MSL0564020LC**

**TO ORDER LEFT VERSION
ADD A "LC" IN THE CODE-CHARTS.
EXAMPLE: MSL0564020 BECOMES MSL0564020LC**

**UM DIE LINKE-VERSION ZU BESTELLEN, BEI DER
ARTIKELBEZEICHNUNG "LC" HINZUFUEGEN.
BEISPIEL: MSL0564020 WIRD DANN MSL0564020LC**

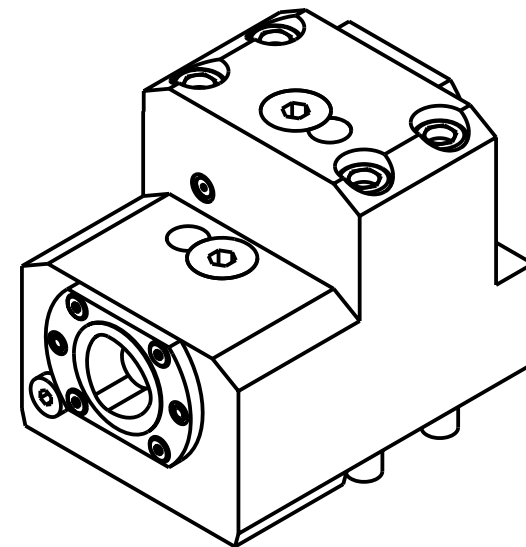
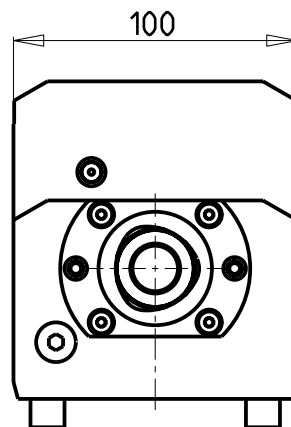
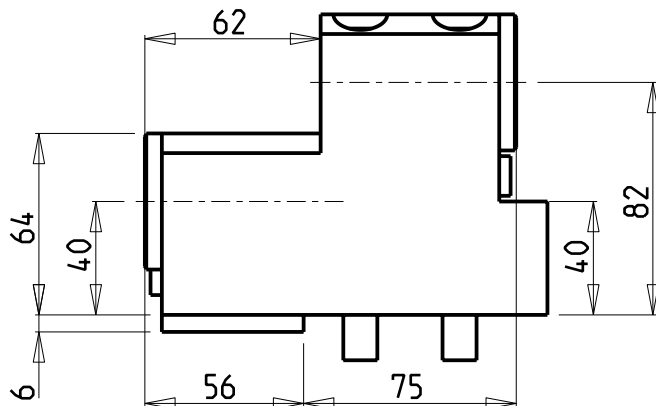
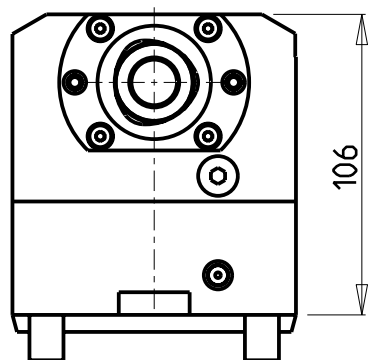

Cod. MT	N°Utensili N°Tools N°Werkzeuge	Lubrificazione int. Coolant through Innenkuehlung	Lubrificazione est. Ext. coolant Aussenkuehlung	TAGLIA Size Masse
MSL0564020	1+1	X	X	C4

DMG-MORI

MOD: SL-ZL200/203/204/250/253/254(MC-SMC) SL2500Y DL-ZL200/250(MC)

PORTAUTENSILE ASSIALE BISPORGENTE MT CAPTO

Axial opposite face twin static tool MT CAPTO

Axial Halter halb vorspringend mit MT CAPTO

Subject to change without notice.

M.T. srl

Via Casino Albini 480
Tel. 0541/956034-957884
Fax 0541/956341

47842 S. GIOVANNI IN M. (RN)
e-mail: mtma@tmarchetti.com
http://www.tmmarchetti.com



PAGINA MSL570-B-40

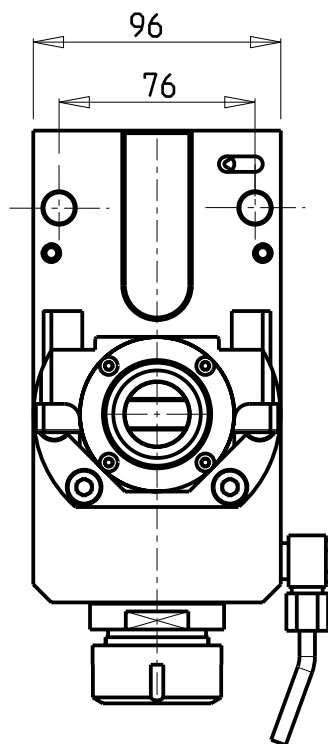
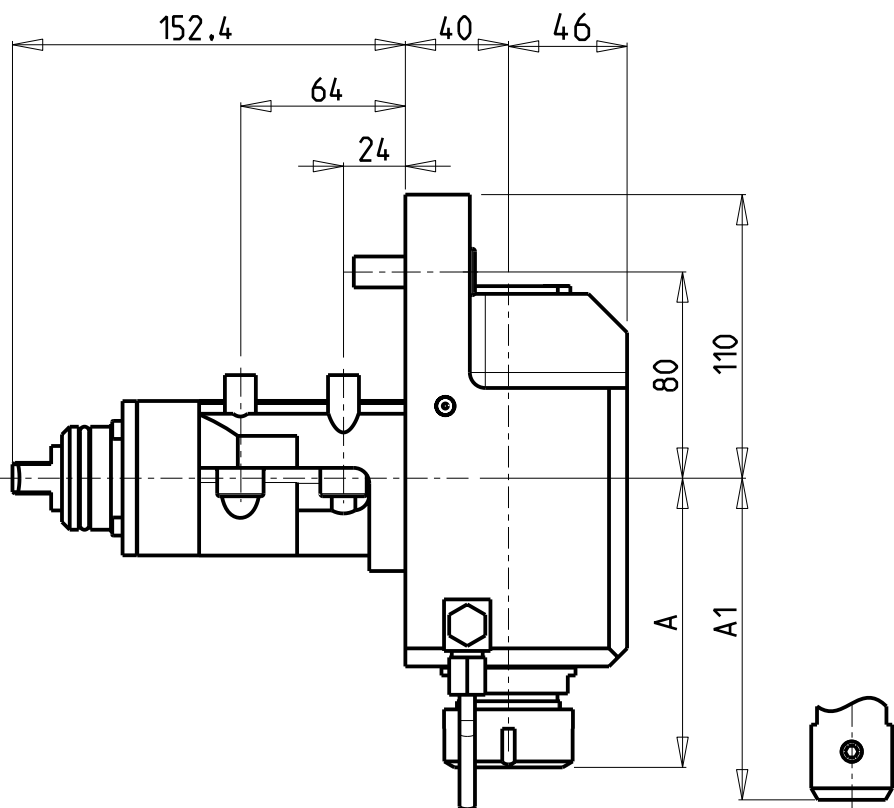

ATTENZIONE - ATTENTION - ACHTUNG

- Per lo smontaggio degli utensili utilizzare sempre la chiave di contrasto come indicato nel manuale d'uso.
- For disassembly of the tools use always the contrast key as mentioned in the user instructions.
- Fuer das Abmontieren der Werkzeuge immer den Gegenschlüssel benutzen wie in der Bedienungsanleitung erwäehnt.

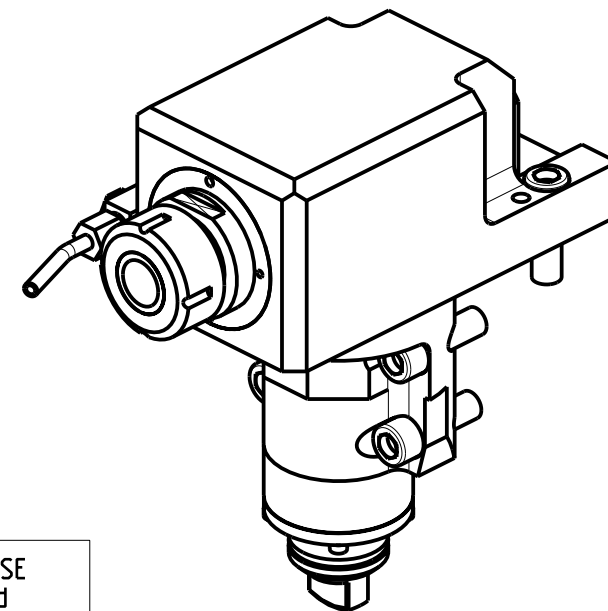

Cod. MT	Mandrino Spindle Spindel	I	RPM	Coppia Max Max Torque Max Drehmoment	Lubrificazione int. Coolant through Innenkuehlung	Lubrificazione est. Ext. coolant Aussenkuehlung	A	A1	CHIAVI NON INCLUSE Keys not included Schluesssel nicht einbegriffen	
M0290132	ER32	1:1	6000	70Nm	P=70bar	X	112.16	-	CHUB46	CHSTER32
M0290232	ER32	1:1	6000	70Nm	-	X	112.16	-	CHUB46	CHSTER32
M0290140	ER40	1:1	6000	70Nm	P=70bar	X	115.16	-	CHUB46	CHSTER40
M0290332	WELDON 32	1:1	6000	70Nm	P=70bar	X	-	131.5	-	-

DMG-MORI
MOD: SL300/303

MODULO MOTORIZZATO ASSIALE
Axial driven tool
Axial angetriebenes Werkzeug

Subject to change without notice.

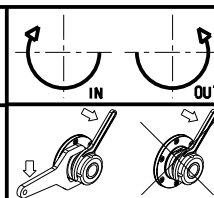

M.T. srl

Via Casino Albini 480
Tel. 0541/956034-957884
Fax 0541/956341
47842 S. GIOVANNI IN M. (RN)
e-mail: mtma@mtmarchetti.com
http://www.mtmarchetti.com



PAGINA MSL150-3-10

ATTENZIONE - ATTENTION - ACHTUNG

- Per lo smontaggio degli utensili utilizzare sempre la chiave di contrasto come indicato nel manuale d'uso.
- For disassembly of the tools use always the contrast key as mentioned in the user instructions.
- Fuer das Abmontieren der Werkzeuge immer den Gegenschlüssel benutzen wie in der Bedienungsanleitung erwaeht.

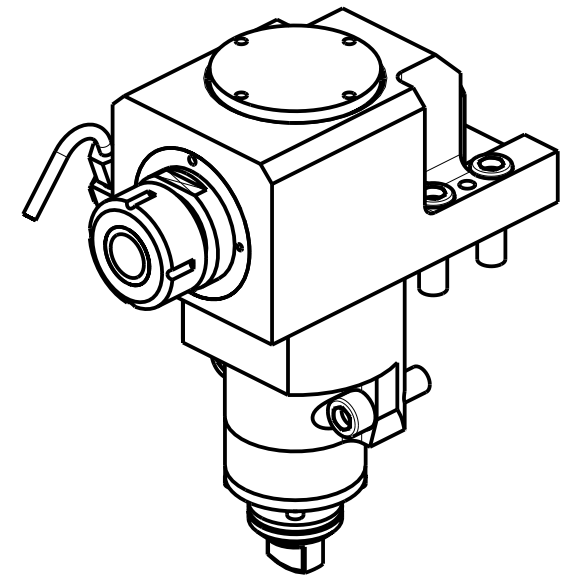
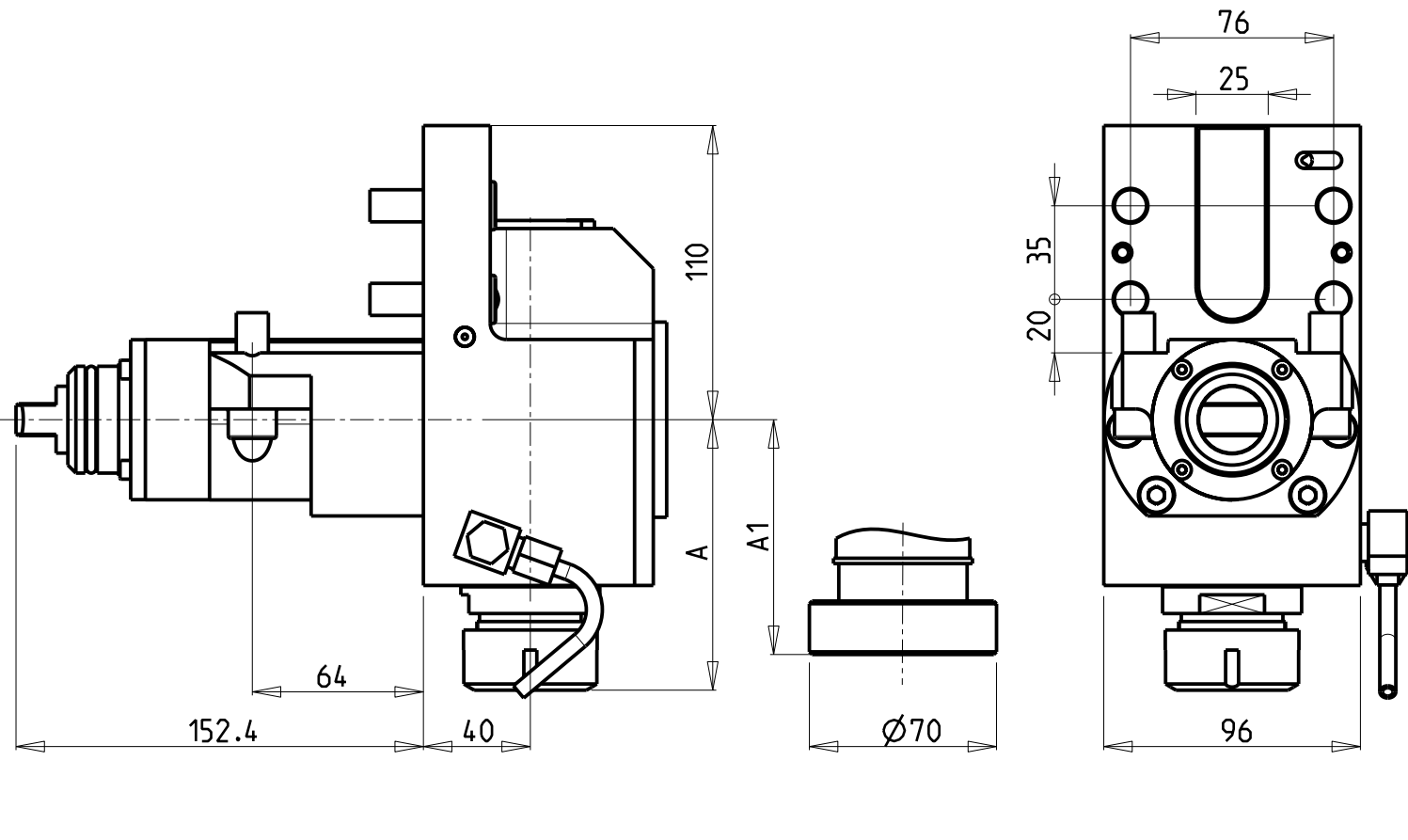

Cod. MT	Mandrino Spindle Spindel	I	RPM	Coppia Max Max Torque Max Drehmoment	Lubrificazione est. Ext. coolant Ausseukuehlung	A	A1	CHIAVI NON INCLUSE Keys not included Schluesssel nicht einbegriffen	
M0100832	ER32	2:1	3000	90Nm	X	101.16	-	CHUB46	CHSTER32
M0100470	Ø70	2:1	3000	90Nm	X	-	98.5	-	-

DMG-MORI
MOD: SL300/303

MODULO MOTORIZZATO ASSIALE RIDOTTO I=2:1
Axial geared-down I=2:1 driven tool
Axial angetriebenes Werkzeug untersetzt I=2:1

Subject to change without notice.

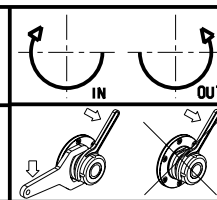

M.T. srl
Via Casino Albini 480
Tel. 0541/956034-957884
Fax 0541/956341
47842 S. GIOVANNI IN M. (RN)
e-mail: mtma@mtmarchetti.com
http://www.mtmarchetti.com



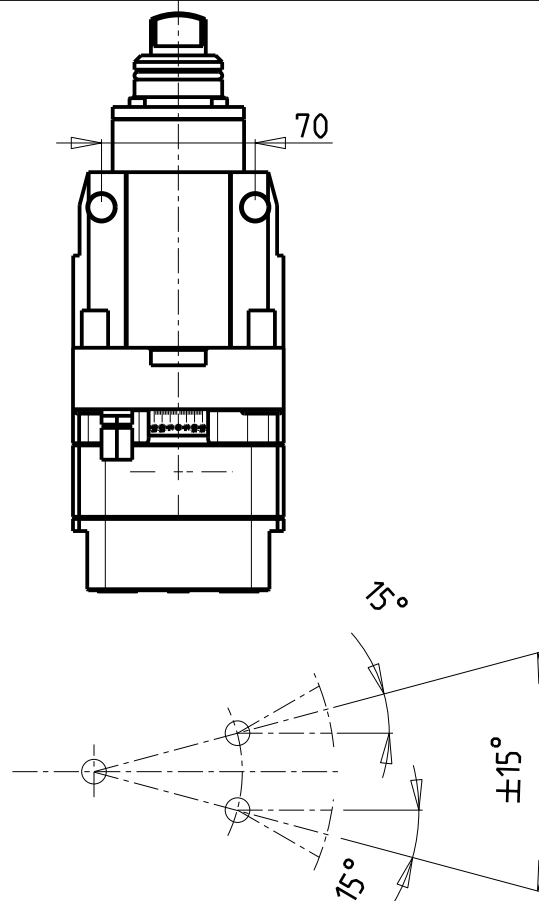
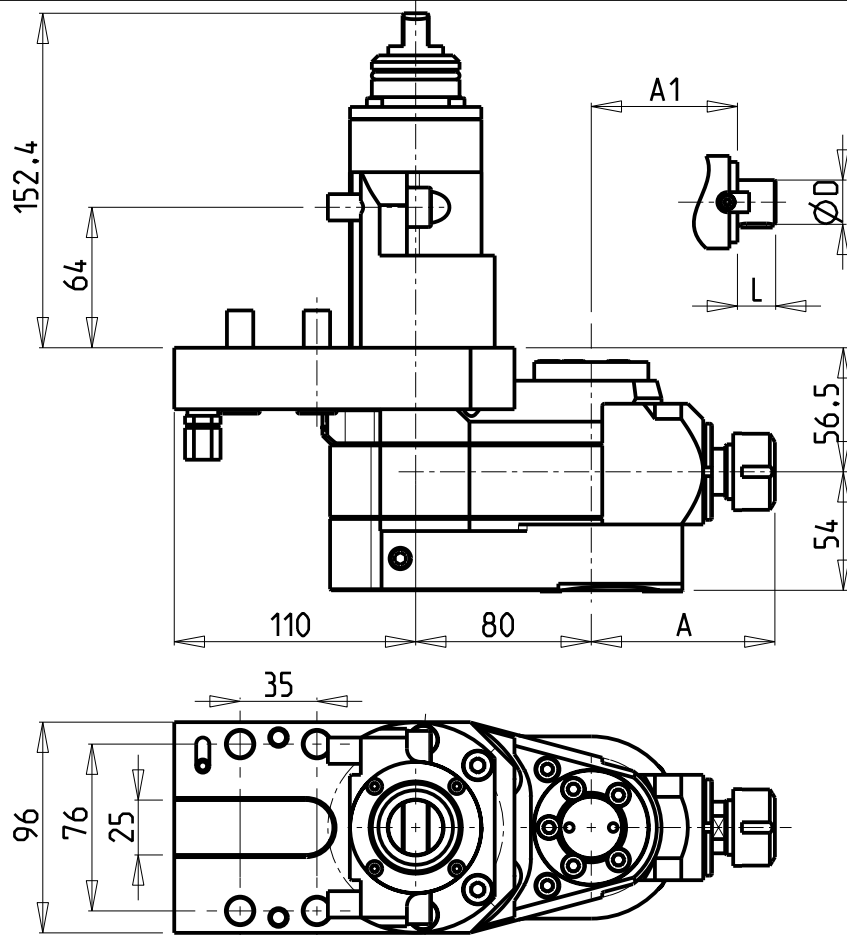

ATTENZIONE - ATTENTION - ACHTUNG

- Per lo smontaggio degli utensili utilizzare sempre la chiave di contrasto come indicato nel manuale d'uso.
- For disassembly of the tools use always the contrast key as mentioned in the user instructions.
- Fuer das Abmontieren der Werkzeuge immer den Gegenschlüssel benutzen wie in der Bedienungsanleitung erwaeht.

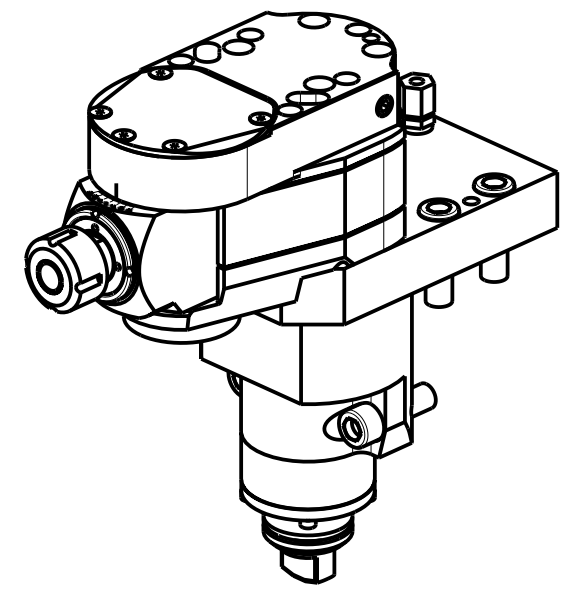

Cod. MT	Mandrino Spindle Spindel	I	RPM	Coppia Max Max Torque Max Drehmoment	Lubrificazione est. Ext. coolant Aussenkuehlung	A	A1	D	L	CHIAVI INCLUSE Keys included Schluessel inbegriffen
M0110020	ER20	1:1	6000	40Nm	X	84.16				MNL0210007 o CHUB36 CHSTER20
M0110025	ER25	1:1	6000	40Nm	X	85.66				MNL0210007 o CHUB36 CHSTER25
M0111617	Ø16x17	1:1	6000	40Nm	X	-	65	16	17	MNL0210007 o CHUB36 CH_VTCROCE_M08

DMG-MORI
MOD: SL300/303

MODULO MOTORIZZATO INCLINEVOLE ±15° IN Y
±15° Y axis adjustable angle driven tool
Angetriebenes Werkzeug kippbar ±15° in Y

Subject to change without notice.

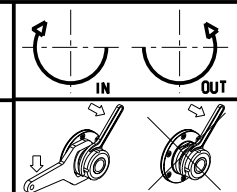

M.T. srl
Via Casino Albini 480
Tel. 0541/956034-957884
Fax 0541/956341
47842 S. GIOVANNI IN M. (RN)
e-mail: mtma@mtmarchetti.com
http://www.mtmarchetti.com

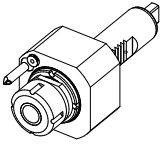
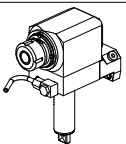
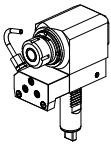
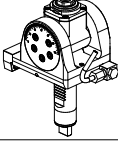
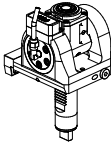
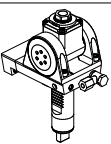
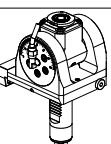
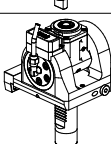
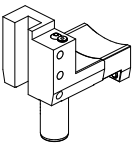
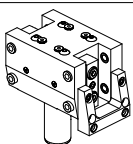
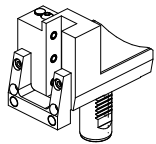
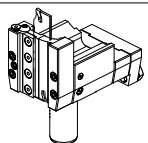

PAGINA MSL358-3-00

		PAGINA Page Seite
<p>MODULO MOTORIZZATO RADIALE Radial driven tool Radial angetriebenes Werkzeug</p>		MZT010.1.00
<p>MODULO MOTORIZZATO ASSIALE Axial driven tool Axial angetriebenes Werkzeug</p>		MZT150.1.10
<p>MODULO MOTORIZZATO ASSIALE PER CONTROMANDRINO Axial driven tool sub spindle side Axial angetriebenes Werkzeug fuer Gegenspindel</p>		MZT155.1.10
<p>MODULO MOTORIZZATO ORIENTABILE $\pm 90^\circ$ $\pm 90^\circ$ adjustable angle driven tool Angetriebenes Werkzeug schwenkbar $\pm 90^\circ$</p>		MZT335.1.00
<p>MODULO MOTORIZZATO ORIENTABILE $\pm 90^\circ$ CON NONIO DIGITALE $\pm 90^\circ$ adjustable angle driven tool with digital display Angetriebenes Werkzeug schwenkbar $\pm 90^\circ$ mit digital display</p>		MZT335.1.01
<p>MODULO MOTORIZZATO ORIENTABILE $\pm 90^\circ$ $\pm 90^\circ$ adjustable angle driven tool Angetriebenes Werkzeug schwenkbar $\pm 90^\circ$</p>		MZT335.1.10
<p>MODULO MOTORIZZATO ORIENTABILE $\pm 90^\circ$ MOLTIPLICATO I=1:2 $\pm 90^\circ$ adjustable angle driven tool geared-up I=1:2 Angetriebenes Werkzeug schwenkbar $\pm 90^\circ$ uebersetzt I=1:2</p>		MZT336.1.00
<p>MODULO MOTOR. ORIENTABILE $\pm 90^\circ$ MOLTIPL. I=1:2 CON NONIO DIGITALE $\pm 90^\circ$ adjustable angle driven tool geared-up I=1:2 with digital display Angetriebenes Werkzeug schwenkbar $\pm 90^\circ$ uebersetzt I=1:2 mit digital display</p>		MZT336.1.01
<p>PORTAUTENSILE RADIALE SINGOLO QD=20mm / QD=3/4" Radial single static tool QD=20mm / QD=3/4" Radial Single-Werkzeughalter QD=20mm / QD=3/4"</p>		MZT420.1.00
<p>PORTAUTENSILE RADIALE DOPPIO QD=20mm / QD=3/4" Radial double static tool QD=20mm / QD=3/4" Radial Doppel-Werkzeughalter QD=20mm / QD=3/4"</p>		MZT450.1.00
<p>PORTAUT. RADIALE SINGOLO PER CONTROMANDRINO QD=20mm / QD=3/4" Radial single static tool sub spindle side QD=20mm / QD=3/4" Radial Single-Werkzeughalter fuer Gegenspindel QD=20mm / QD=3/4"</p>		MZT480.1.00
<p>PORTAUTENSILE PER LAMA DOPPIO Radial double blade holder Radial Doppel-Abstechhalter</p>		MZT520.1.10

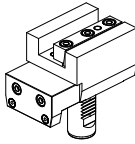
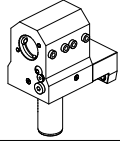
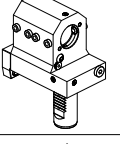
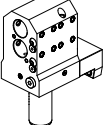
		PAGINA Page Seite
<p>PORTAUTENSILE ASSIALE SINGOLO QD=20mm / QD=3/4"</p> <p>Axial single static tool QD=20mm / QD=3/4"</p> <p>Axial Single-Werkzeughalter QD=20mm / QD=3/4"</p>		MZT550.1.00
<p>PORTAUTENSILE ASSIALE PER BARENO \varnothing32mm / \varnothing1 1/4" / \varnothing40mm H=65mm</p> <p>Axial single boring bar holder \varnothing32mm / \varnothing1 1/4" / \varnothing40mm H=65mm</p> <p>Axial Bohrhalter \varnothing32mm / \varnothing1 1/4" / \varnothing40mm H=65mm</p>		MZT650.1.10
<p>PORTABARENO ARRETR. LATO MANDRINO, PROLUNGATO LATO CONTROM.</p> <p>Rear-set boring bar holder on main spindle side, extended on subspindle side</p> <p>Bohrhalter zurueckversetzt auf Hauptspindel-seite, verlaengert auf Gegenspindel-seite</p>		MZT850.1.00
<p>PORTAUTENSILE ASSIALE PER BARENO 2 POSIZIONI \varnothing25mm / \varnothing1"</p> <p>Axial double boring bar holder \varnothing25mm / \varnothing1"</p> <p>Axial Bohrhalter 2 Positionen \varnothing25mm / \varnothing1"</p>		MZT864.1.00

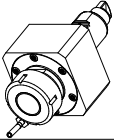
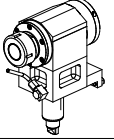
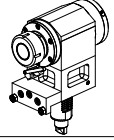
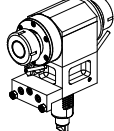
		PAGINA Page Seite
<p>MODULO MOTORIZZATO RADIALE Radial driven tool Radial angetriebenes Werkzeug</p>		MZT010.2.00
<p>MODULO MOTORIZZATO ASSIALE Axial driven tool Axial angetriebenes Werkzeug</p>		MZT150.2.10
<p>MODULO MOTORIZZATO ASSIALE PER CONTROMANDRINO Axial driven tool sub spindle side Axial angetriebenes Werkzeug fuer Gegenspindel</p>		MZT155.2.10
<p>MODULO MOTORIZZATO ASSIALE BISPORGENTE Axial opposite face driven tool Axial angetriebenes Werkzeug halb vorspringend</p>		MZT240.2.10

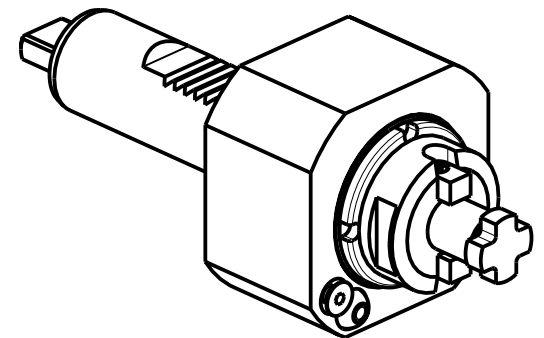
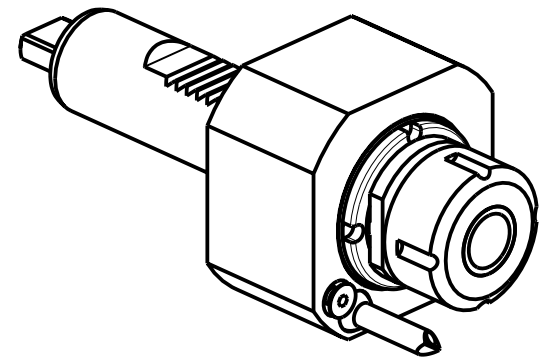
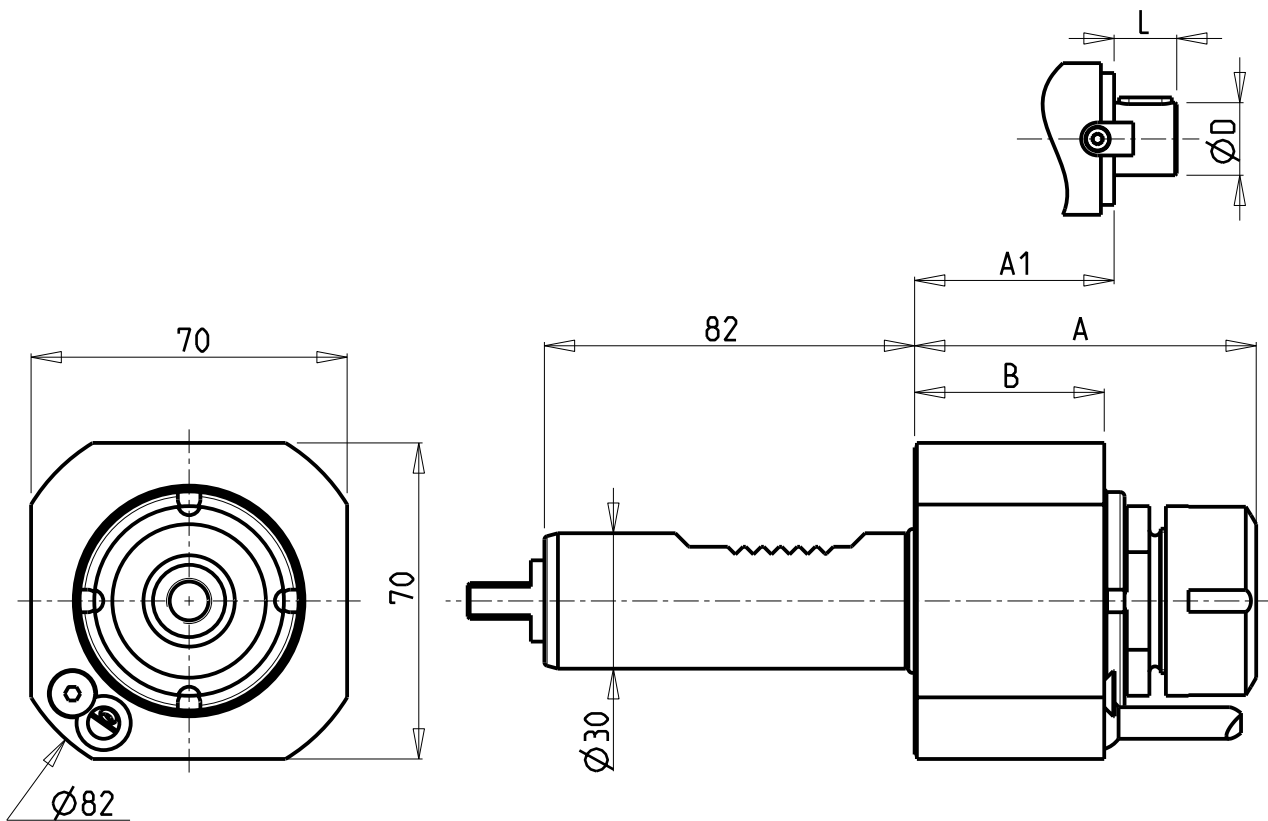

Cod. MT	Mandrino Spindel Spindel	I	RPM	Coppia Max Max Torque Max Drehmoment	Lubrificazione int. Coolant through Innenkuehlung	Lubrificazione est. Ext. coolant Aussenkuehlung	A	A1	B	D	L	CHIAVI NON INCLUSE Keys not included Schluessel nicht einbegriffen	
M0150125	ER25	1:1	6000	40Nm		X	75.66	-	42	-	-	CHUB36	CHSTER25
M0151125	ER25	1:1	6000	40Nm	P=30bar		95.66	-	62	-	-	CHUB36	CHSTER25
M0151617	Ø16x17	1:1	6000	40Nm		X	-	61	42	16	17	CHUB36	CH_VTCROCE_M08
M0152219	Ø22x19	1:1	6000	40Nm		X	-	59	42	22	19	CHUB36	CH_VTCROCE_M10

- Chiave inclusa
- Key included
- Schluessel inbegriffen

DMG-MORI
MOD: ZT1000/1500 12/16 STAZIONI

MODULO MOTORIZZATO RADIALE
Radial driven tool
Radial angetriebenes Werkzeug

Subject to change without notice.

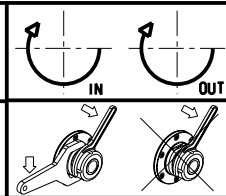

M.T. srl
Via Casino Albini 480
Tel. 0541/956034-957884
Fax 0541/956341
47842 S. GIOVANNI IN M. (RN)
e-mail: mtma@mtmarchetti.com
http://www.mtmarchetti.com



PAGINA MZT010-1-00

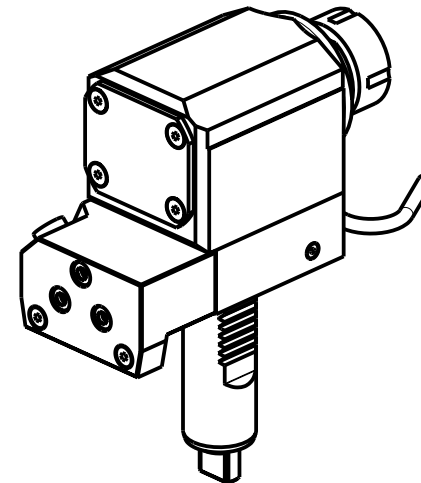
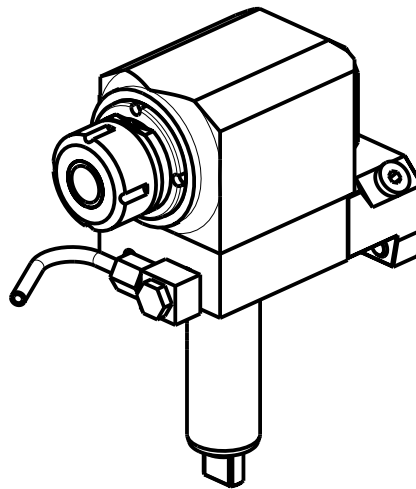
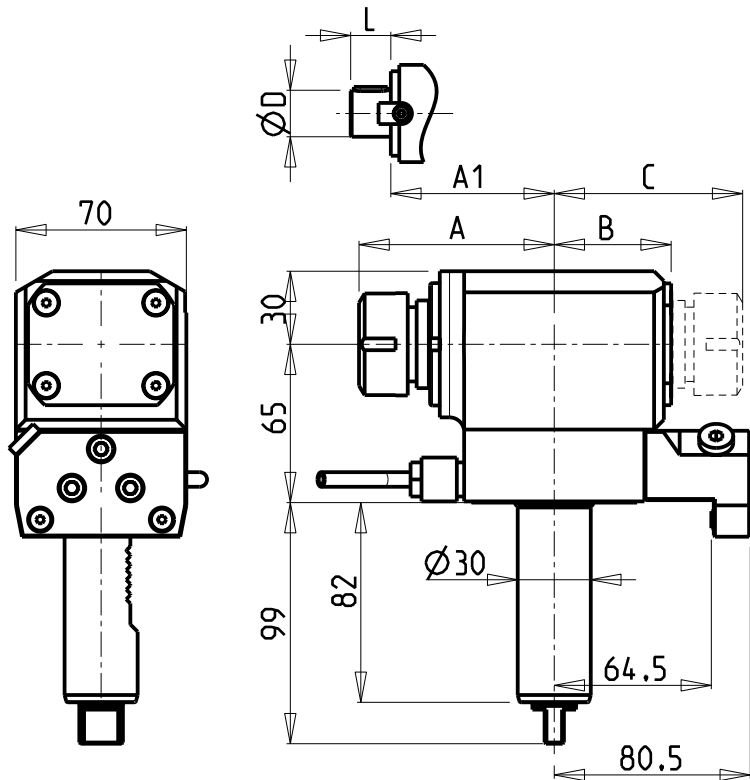

ATTENZIONE - ATTENTION - ACHTUNG

- Per lo smontaggio degli utensili utilizzare sempre la chiave di contrasto come indicato nel manuale d'uso.
- For disassembly of the tools use always the contrast key as mentioned in the user instructions.
- Fuer das Abmontieren der Werkzeuge immer den Gegenschlüssel benutzen wie in der Bedienungsanleitung erwäehnt.

- Chiave inclusa
- Key included
- Schlüssel inbegriffen

Cod. MT	Cod. MORI-SEIKI	Mandrino Spindle Spindel	I	RPM	Coppia Max Max Torque Max Drehmoment	Lubr.interna Coolant through Innenkuehlung	Lubr.esterna Ext. coolant Aussenkuehlung	A	A1	B	C	D	L	CHIAVI NON INCLUDE Keys not included Schlüssel nicht einbegriffen	
M0121425	T32406	ER25	1:1	6000	40Nm		X	80.16	-	48	-	-	-	CHUB38	CHSTER25
M0121525	T32415	ER25	1:1	6000	40Nm	P=70bar	X	80.16	-	59	-	-	-	CHUB38	CHSTER25
M0132525	T32408	ER25+ER25	1:1	6000	40Nm		X	80.16	-	-	73.66	-	-	CHUB36	CHSTER25
M0121617	-	Ø16x17	1:1	6000	40Nm		X	-	63	48	-	16	17	CHUB36	CH_VTCROCE_M08 ▪
M0122219	-	Ø22x19	1:1	6000	40Nm		X	-	63	48	-	22	19	CHUB36	CH_VTCROCE_M10 ▪
M0122721	-	Ø27x21	1:1	6000	40Nm		X	-	65.5	48	-	27	21	CHUB36	CH_VTCROCE_M12 ▪

DMG-MORI
MOD: ZT1000/1500 12/16 STAZIONI

MODULO MOTORIZZATO ASSIALE
Axial driven tool
Axial angetriebenes Werkzeug

Subject to change without notice.

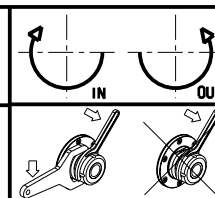

M.T. srl
Via Casino Albini 480
Tel. 0541/956034-957884
Fax 0541/956341
47842 S. GIOVANNI IN M. (RN)
e-mail: mtma@mtmarchetti.com
http://www.mtmarchetti.com



PAGINA MZT150-1-10

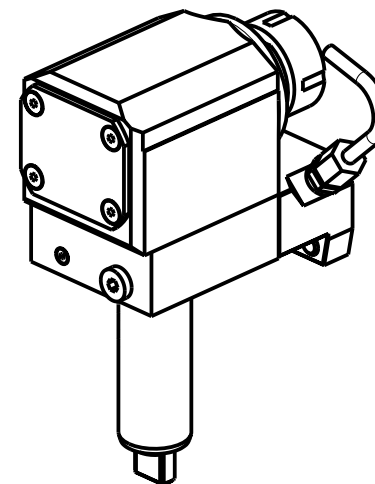
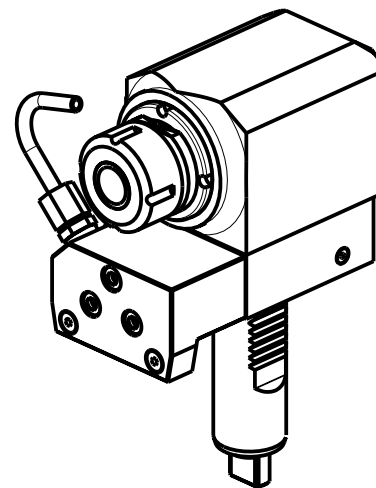
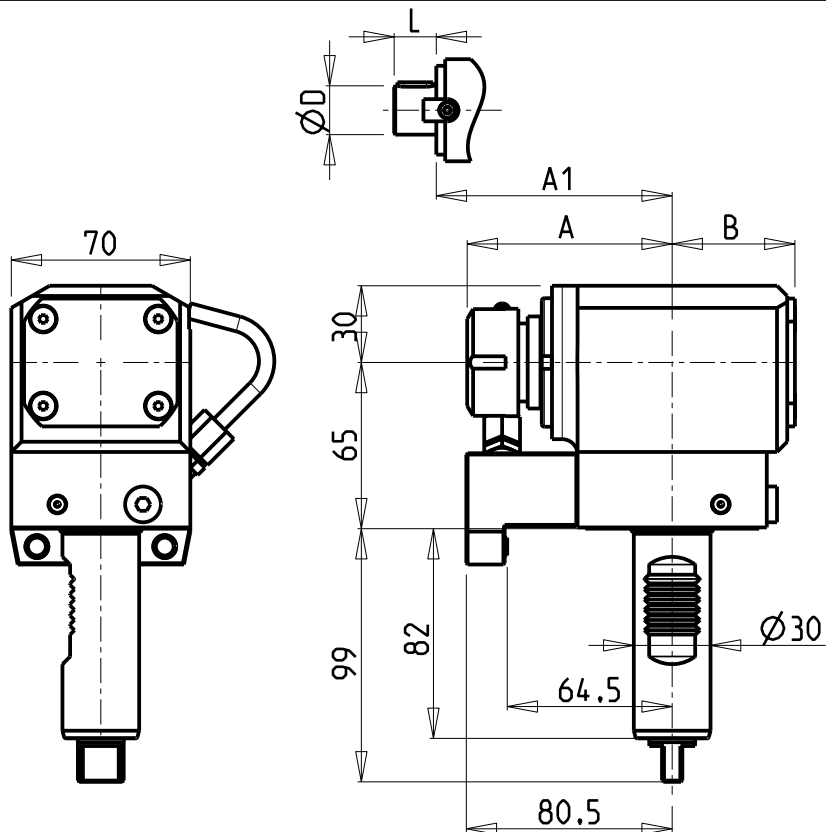

ATTENZIONE - ATTENTION - ACHTUNG

- Per lo smontaggio degli utensili utilizzare sempre la chiave di contrasto come indicato nel manuale d'uso.
- For disassembly of the tools use always the contrast key as mentioned in the user instructions.
- Fuer das Abmontieren der Werkzeuge immer den Gegenschlüssel benutzen wie in der Bedienungsanleitung erwaeht.

• Chiave inclusa

• Key included

• Schluessel inbegriffen

Cod. MT	Cod. MORI-SEIKI	Mandrino Spindle Spindel	I	RPM	Coppia Max Max Torque Max Drehmoment	Lubrificazione int. Coolant through Innenkuehlung	Lubrificazione est. Ext. coolant Aussenkuehlung	A	A1	B	D	L	CHIAVI NON INCLUSE Keys not included Schluessel nicht einbegriffen	
M0141425	T32407	ER25	1:1	6000	40Nm	-	X	80.16	-	48	-	-	CHUB38	CHSTER25
M0141525	-	ER25	1:1	6000	40Nm	P=70bar	X	80.16	-	59	-	-	CHUB38	CHSTER25
M0141617	-	Ø16x17	1:1	6000	40Nm	-	X	-	63	48	16	17	CHUB36	CH_VTCROCE_M08 ▪
M0142219	-	Ø22x19	1:1	6000	40Nm	-	X	-	63	48	22	19	CHUB36	CH_VTCROCE_M10 ▪
M0142721	-	Ø27x21	1:1	6000	40Nm	-	X	-	65.5	48	27	21	CHUB36	CH_VTCROCE_M12 ▪

DMG-MORI

MOD: ZT1000/1500 12/16 STAZIONI

MODULO MOTORIZ. ASSIALE PER CONTROMANDR.

Axial driven tool sub spindle side

Axial angetriebenes Werkzeug fuer Gegenspindel

Subject to change without notice.

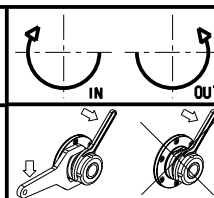

M.T. srl

Via Casino Albini 480
Tel. 0541/956034-957884
Fax 0541/956341

47842 S. GIOVANNI IN M. (RN)
e-mail: mtma@mtmarchetti.com
http://www.mtmarchetti.com



PAGINA MZT155-1-10

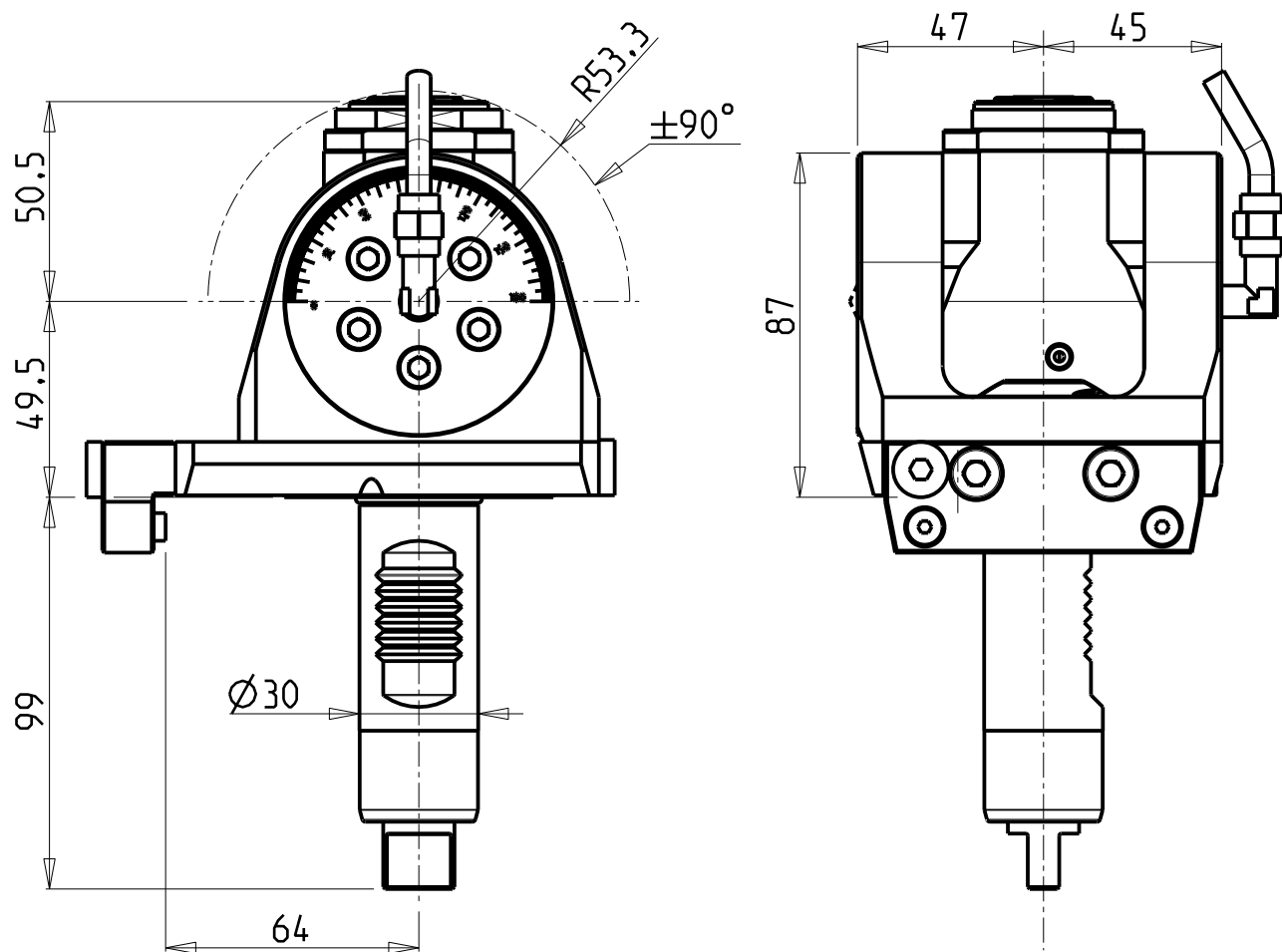

ATTENZIONE - ATTENTION - ACHTUNG

- Per lo smontaggio degli utensili utilizzare sempre la chiave di contrasto come indicato nel manuale d'uso.
- For disassembly of the tools use always the contrast key as mentioned in the user instructions.
- Fuer das Abmontieren der Werkzeuge immer den Gegenschlüssel benutzen wie in der Bedienungsanleitung erwaeht.

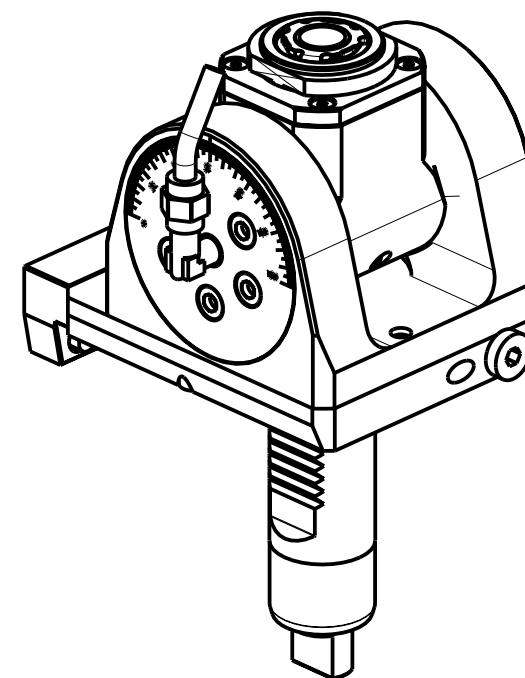

Cod. MT	Mandrino Spindle Spindel	I	RPM	Coppia Max Max Torque Max Drehmoment	Lubrificazione int. Coolant through Innenkuehlung	Lubrificazione est. Ext. coolant Aussenkuehlung	CHIAVI INCLUDE Keys included Schluessel inbegriffen		
MZT0050120	ER A 20	1:1	6000	30Nm		X	CHUB36	CHUB22	CHTAER20ZC
MZT0050220	ER A 20	1:1	6000	30Nm	P=70bar	X	CHUB36	CHUB22	CHTAER20ZC

DMG-MORI
MOD: ZT1000/1500 12 STAZIONI

MODULO MOTORIZZATO ORIENTABILE ±90°
±90° adjustable angle driven tool
Angetriebenes Werkzeug schwenkbar ±90°

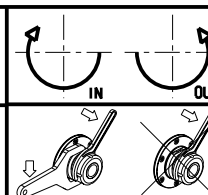

M.T. srl
Via Casino Albini 480
Tel. 0541/956034-957884
Fax 0541/956341
47842 S. GIOVANNI IN M. (RN)
e-mail: mtma@mtmarchetti.com
http://www.mtmarchetti.com



PAGINA MZT335-1-00

Subject to change without notice.

10/2021

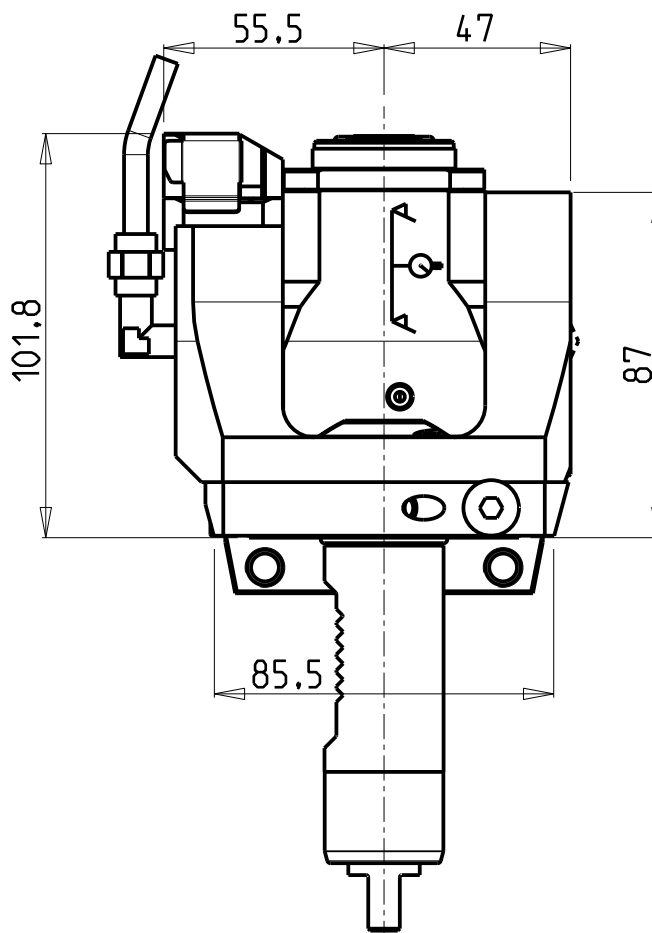
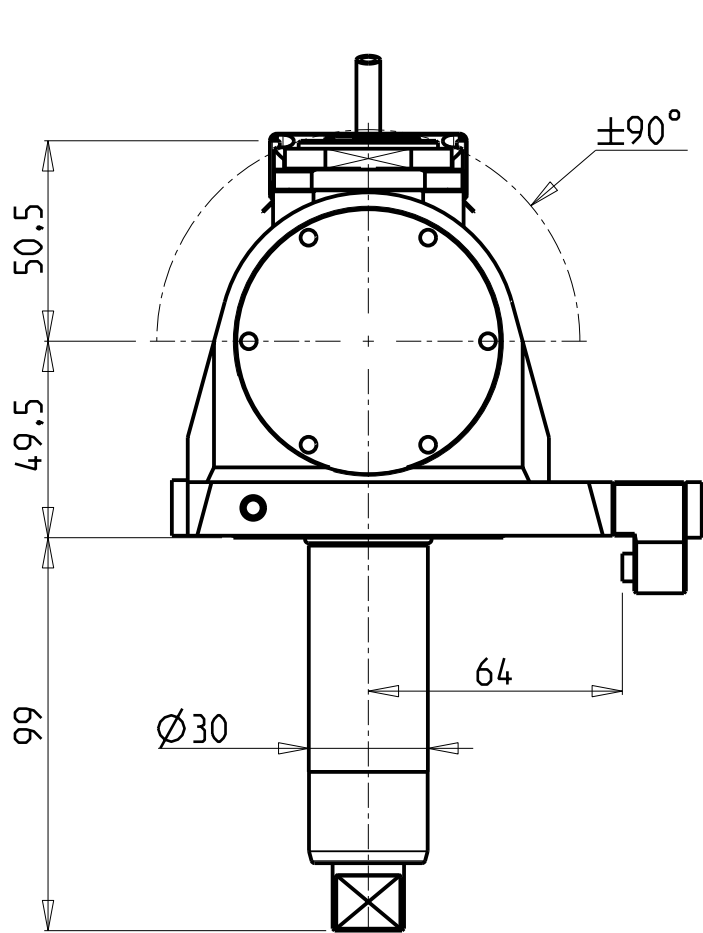

ATTENZIONE - ATTENTION - ACHTUNG

- Per lo smontaggio degli utensili utilizzare sempre la chiave di contrasto come indicato nel manuale d'uso.
- For disassembly of the tools use always the contrast key as mentioned in the user instructions.
- Fuer das Abmontieren der Werkzeuge immer den Gegenschlüssel benutzen wie in der Bedienungsanleitung erwaeht.

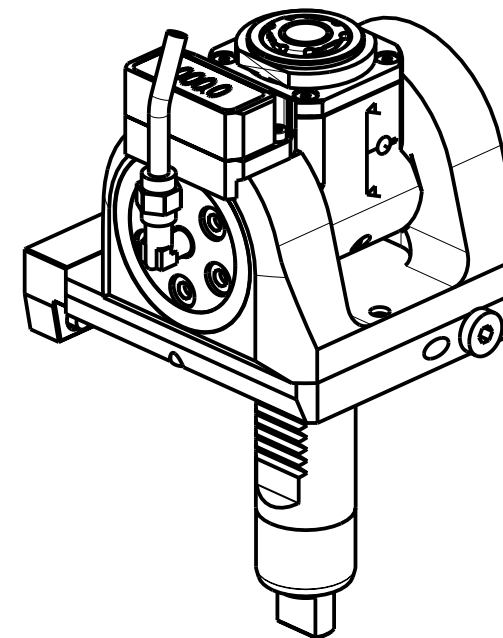

Cod. MT	Mandrino Spindle Spindel	I	RPM	Coppia Max Max Torque Max Drehmoment	Lubrificazione int. Coolant through Innenkuehlung	Lubrificazione est. Ext. coolant Aussenkuehlung	CHIAVI INCLUSE Keys included Schluessel inbegriffen		
MZT0055120	ER A 20	1:1	6000	30Nm	-	X	CHUB36	CHUB22	CHTAER20ZC
MZT0055220	ER A 20	1:1	6000	30Nm	P=70bar	X	CHUB36	CHUB22	CHTAER20ZC

DMG-MORI
MOD: ZT1000/1500 12 STAZIONI

MODULO MOTORIZZATO ORIENTABILE $\pm 90^\circ$ CON NONIO DIGITALE
 $\pm 90^\circ$ adjustable angle driven tool with digital display
Angetriebenes Werkzeug schwenkbar $\pm 90^\circ$ mit digital display

Subject to change without notice.

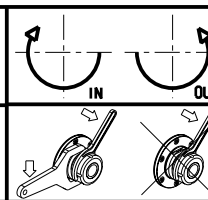

M.T. srl
Via Casino Albini 480
Tel. 0541/956034-957884
Fax 0541/956341
47842 S. GIOVANNI IN M. (RN)
e-mail: mtma@mtmarchetti.com
http://www.mtmarchetti.com



PAGINA MZT335-1-01

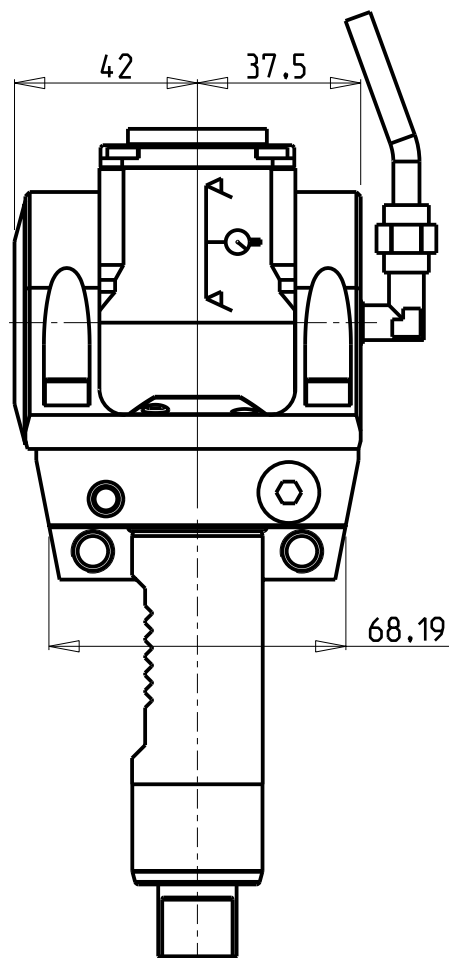
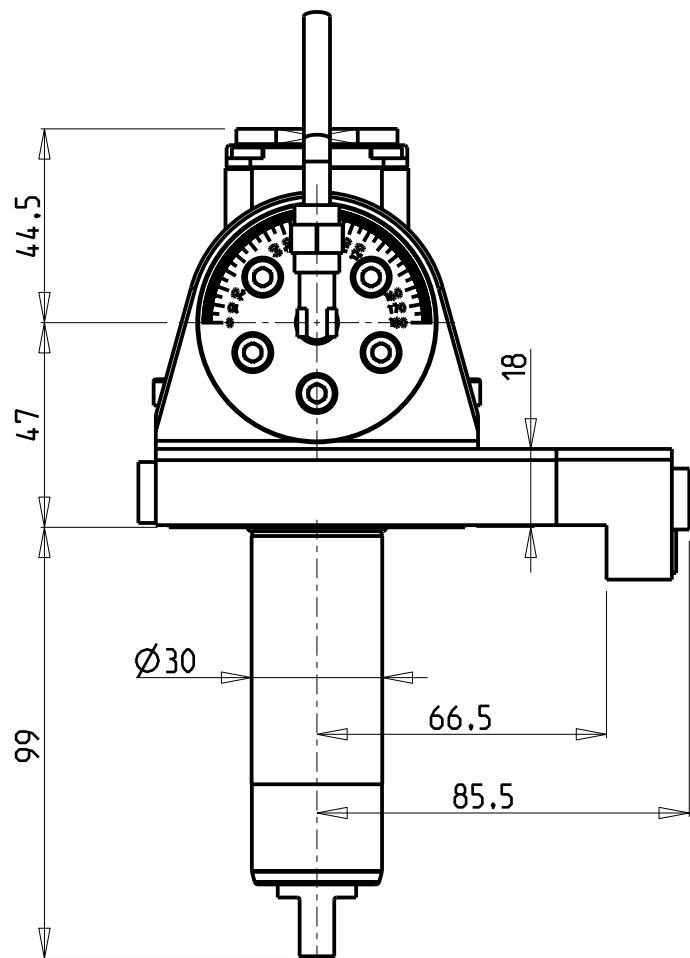

ATTENZIONE - ATTENTION - ACHTUNG

- Per lo smontaggio degli utensili utilizzare sempre la chiave di contrasto come indicato nel manuale d'uso.
- For disassembly of the tools use always the contrast key as mentioned in the user instructions.
- Fuer das Abmontieren der Werkzeuge immer den Gegenschlüssel benutzen wie in der Bedienungsanleitung erwäehnt.

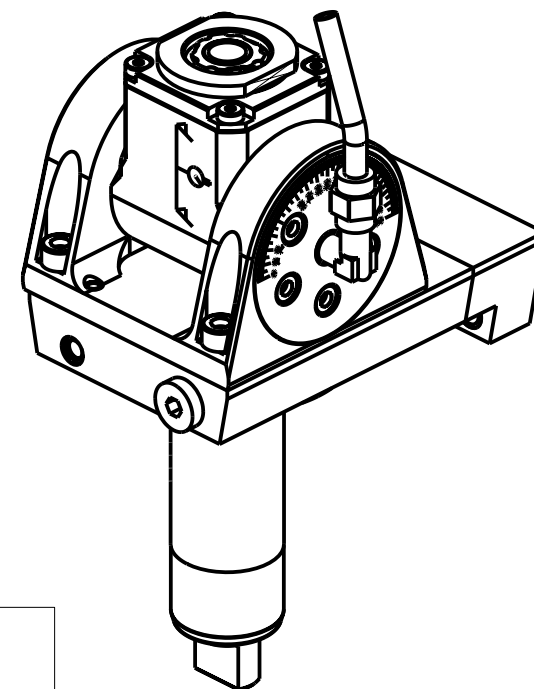

Cod. MT	Mandrino Spindle Spindel	I	RPM	Coppia Max Max Torque Max Drehmoment	Lubr.interna Coolant through Innenkuehlung	Lubrificazione est. Ext. coolant Aussenkuehlung	CHIAVI INCLUDE Keys included Schluesssel inbegriffen			
MZT0040116	ERA16	1:1	6000	20Nm	-	X	CHUB19_SP3	CHUB32	CHESL05	CHTAER16ZC
MZT0040216	ERA16	1:1	6000	20Nm	P=70bar	X	CHUB19_SP3	CHUB32	CHESL05	CHTAER16ZC

DMG-MORI
MOD: ZT1000/1500 12/16 STAZIONI

MODULO MOTORIZZATO ORIENTABILE ±90°
±90° adjustable angle driven tool
Angetriebenes Werkzeug schwenkbar ±90°

Subject to change without notice.

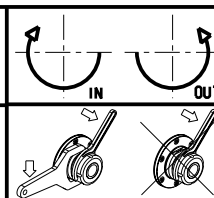

M.T. srl
Via Casino Albini 480
Tel. 0541/956034-957884
Fax 0541/956341
47842 S. GIOVANNI IN M. (RN)
e-mail: mtma@mtmarchetti.com
http://www.mtmarchetti.com



PAGINA MZT335-1-10

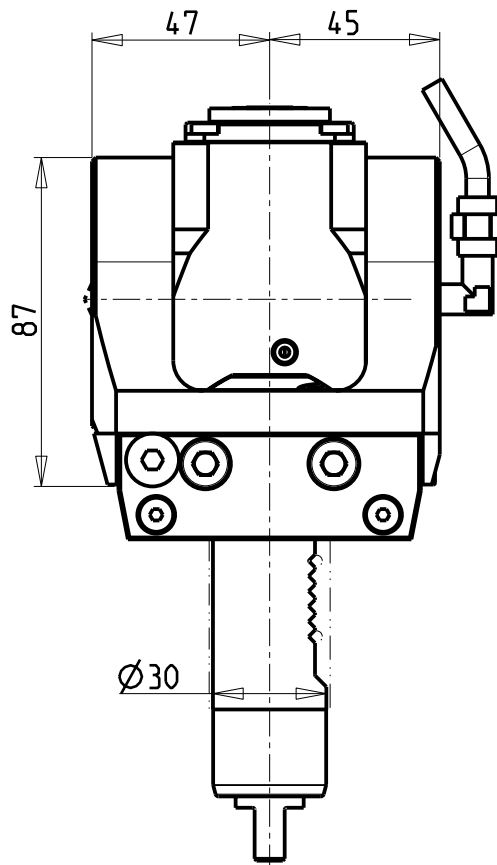
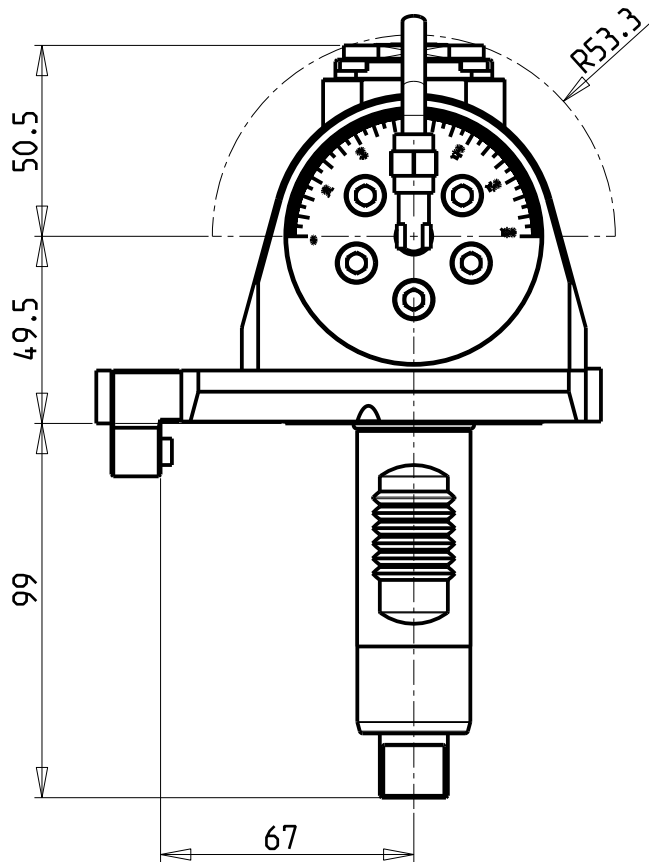

ATTENZIONE - ATTENTION - ACHTUNG

- Per lo smontaggio degli utensili utilizzare sempre la chiave di contrasto come indicato nel manuale d'uso.
- For disassembly of the tools use always the contrast key as mentioned in the user instructions.
- Fuer das Abmontieren der Werkzeuge immer den Gegenschlüssel benutzen wie in der Bedienungsanleitung erwäehnt.

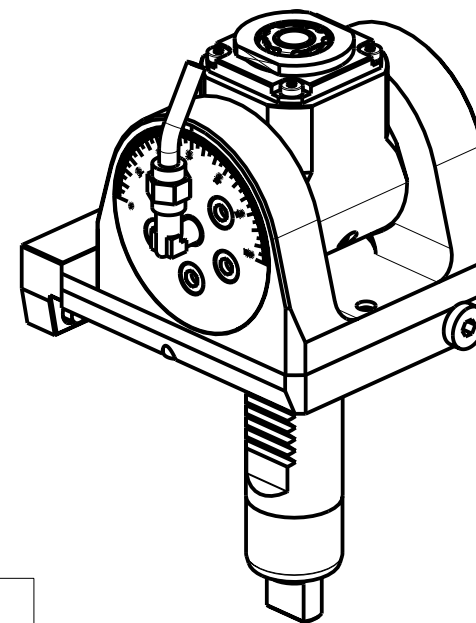

Cod. MT	Mandrino Spindle Spindel	I	RPM	Coppia Max Max Torque Max Drehmoment	Lubrificazione int. Coolant through Innenkuehlung	Lubrificazione est. Ext. coolant Aussenkuehlung	CHIAVI INCLUSE Keys included Schluesssel inbegriffen		
MZT0050316	ERA16	1:2	12000	8Nm		X	CHUB19_SP3	CHUB32	CHTAER16ZC
MZT0050416	ERA16	1:2	12000	8Nm	P=70bar	X	CHUB19_SP3	CHUB32	CHTAER16ZC

DMG-MORI
MOD: ZT1000/1500 12 STAZIONI

MODULO MOTORIZZATO ORIENTABILE +/-90° MOLTIPLICATO I=1:2
+/-90° adjustable angle driven tool geared-up I=1:2
Angetriebenes Werkzeug schwenkbar +/-90° uebersetzt I=1:2

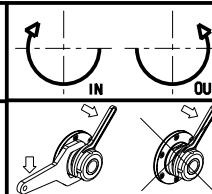

M.T. srl
Via Casino Albini 480
Tel. 0541/956034-957884
Fax 0541/956341
47842 S. GIOVANNI IN M. (RN)
e-mail: mtma@mtmarchetti.com
http://www.mtmarchetti.com



PAGINA MZT336-1-00

Subject to change without notice.

10/2021

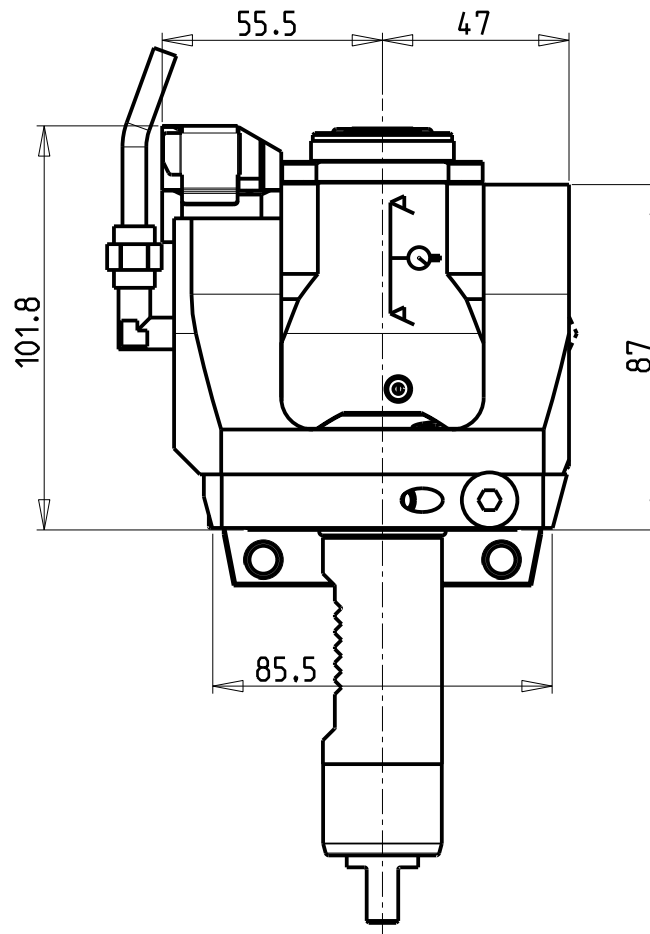
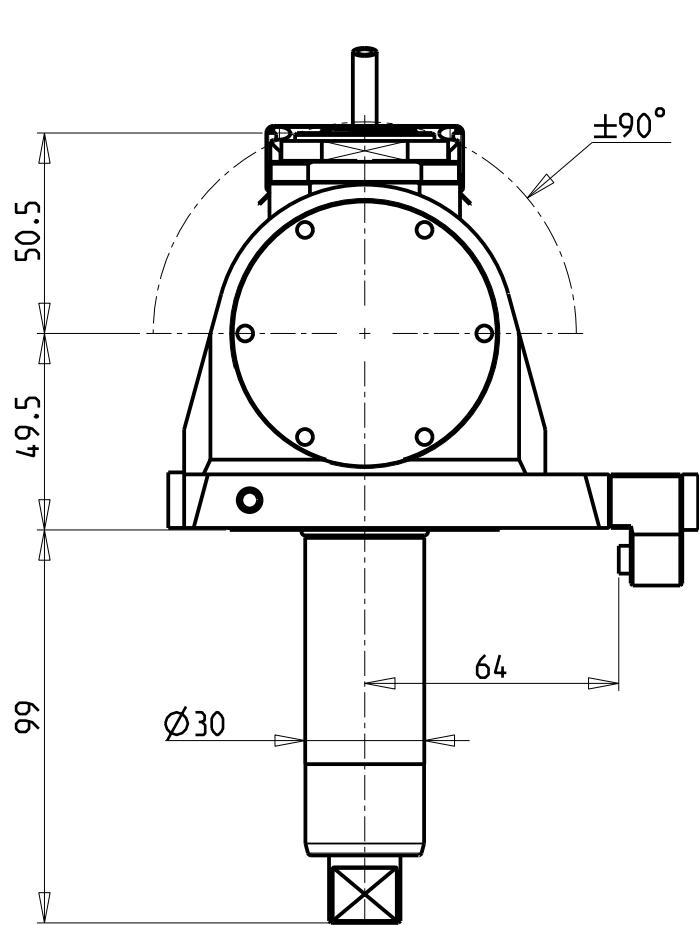

ATTENZIONE - ATTENTION - ACHTUNG

- Per lo smontaggio degli utensili utilizzare sempre la chiave di contrasto come indicato nel manuale d'uso.
- For disassembly of the tools use always the contrast key as mentioned in the user instructions.
- Fuer das Abmontieren der Werkzeuge immer den Gegenschlüssel benutzen wie in der Bedienungsanleitung erwäehnt.

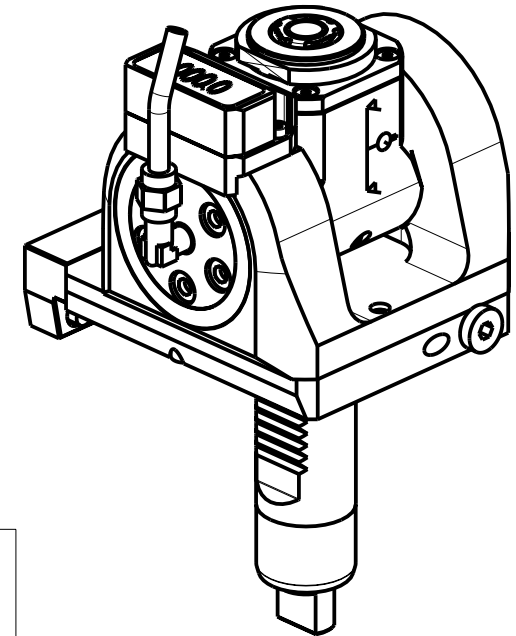

Cod. MT	Mandrino Spindle Spindel	I	RPM	Coppia Max Max Torque Max Drehmoment	Lubrificazione int. Coolant through Innenkuehlung	Lubrificazione est. Ext. coolant Aussenkuehlung	CHIAVI INCLUSE Keys included Schluessel inbegriffen		
MZT0055316	ERA16	1:2	12000	8Nm	-	X	CHUB19_SP3	CHUB32	CHTAER16ZC
MZT0055416	ERA16	1:2	12000	8Nm	P=70bar	X	CHUB19_SP3	CHUB32	CHTAER16ZC

DMG-MORI
MOD: ZT1000/1500 12 STAZIONI

MODULO MOTORIZZATO ORIENTABILE $\pm 90^\circ$ MOLTIPLICATO 1=1:2 CON NONIO DIGITALE
 $\pm 90^\circ$ adjustable angle driven tool geared-up 1=1:2 with digital display
 Angetriebenes Werkzeug schwenkbar $\pm 90^\circ$ uebersetzt 1=1:2 mit digital display

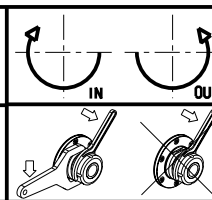

M.T. srl
 Via Casino Albini 480
 Tel. 0541/956034-957884
 Fax 0541/956341
 47842 S. GIOVANNI IN M. (RN)
 e-mail: mtma@mtmarchetti.com
 http://www.mtmarchetti.com



PAGINA MZT336-1-01

Subject to change without notice.

10/2021

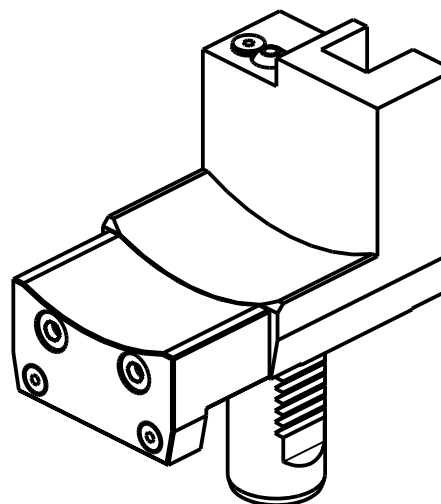
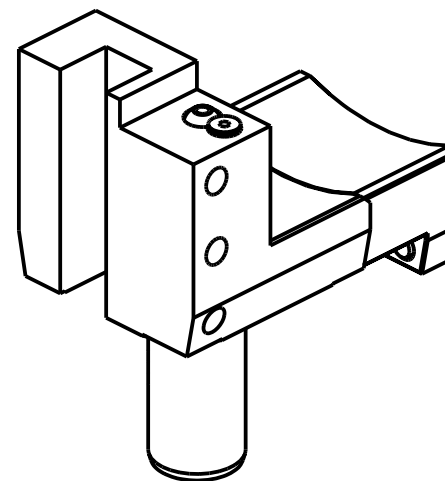
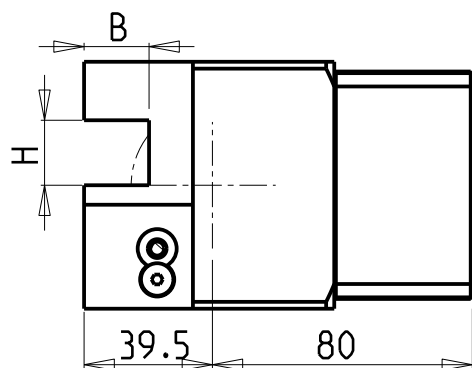
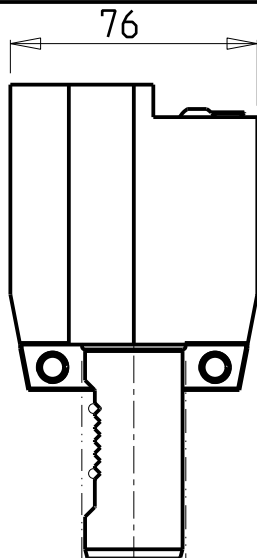
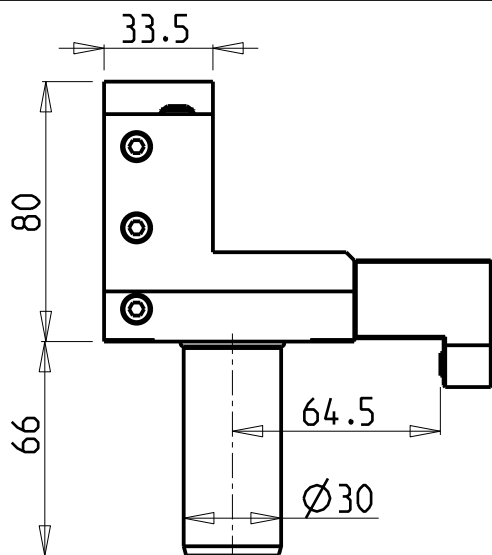

Cod. MT	Cod. MORI-SEIKI	N°Utensili N°Tools N°Werkzeuge	Misure Dimensions Masse	B	H
M0192000	T00336	1	mm	20	20
M0191905	-	1	Inch	3/4"	3/4"

DMG-MORI
MOD: ZT1000/1500 12/16 STAZIONI

PORTAUTENSILE RADIALE SINGOLO QD=20mm / QD=3/4"
Radial single static tool QD=20mm / QD=3/4"
Radial Single-Werkzeughalter QD=20mm / QD=3/4"

Subject to change without notice.

M.T. srl

Via Casino Albini 480
Tel. 0541/956034-957884
Fax 0541/956341
47842 S. GIOVANNI IN M. (RN)
e-mail: mtma@mtmarchetti.com
<http://www.mtmarchetti.com>



PAGINA MZT420-1-00

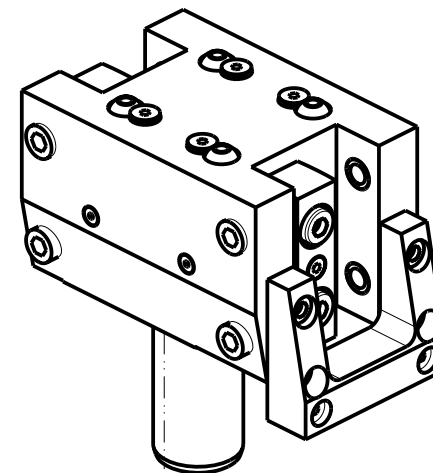
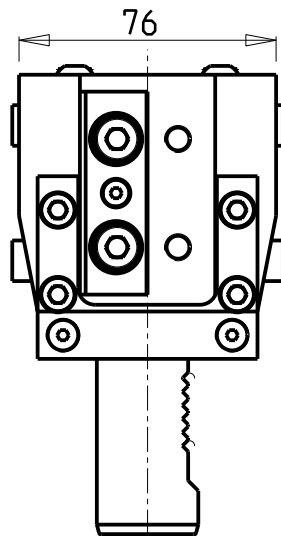
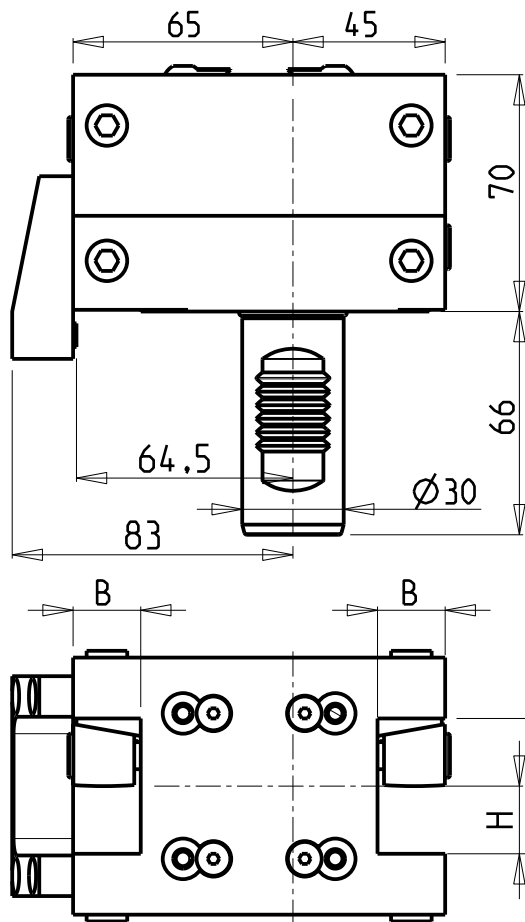

Cod. MT	Cod. MORI-SEIKI	N°Utensili N°Tools N°Werkzeuge	Misure Dimensions Masse	B	H
M0172000	T00331	2/4	mm	20	20
M0171905	-	2/4	Inch	3/4"	3/4"

DMG-MORI
 MOD: ZT1000/1500 12/16 STAZIONI

PORTAUTENSILE RADIALE DOPPIO QD=20mm / QD=3/4"
 Radial double static tool QD=20mm / QD=3/4"
 Radial Doppel-Werkzeughalter QD=20mm / QD=3/4"

Subject to change without notice.

M.T. srl
 Via Casino Albini 480
 Tel. 0541/956034-957884
 Fax 0541/956341
 47842 S. GIOVANNI IN M. (RN)
 e-mail: mtma@mtmarchetti.com
 http://www.mtmarchetti.com



PAGINA MZT450-1-00

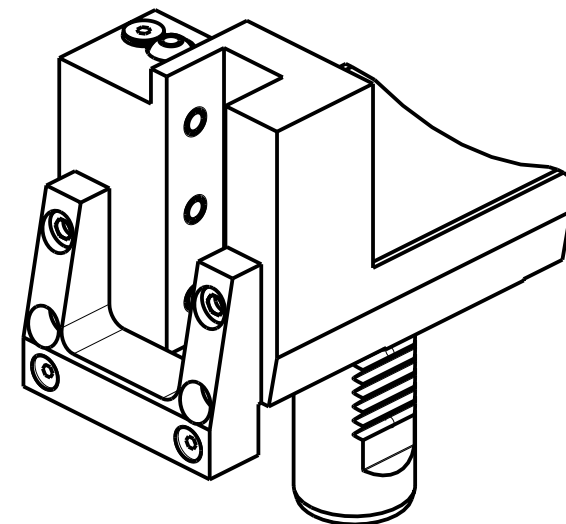
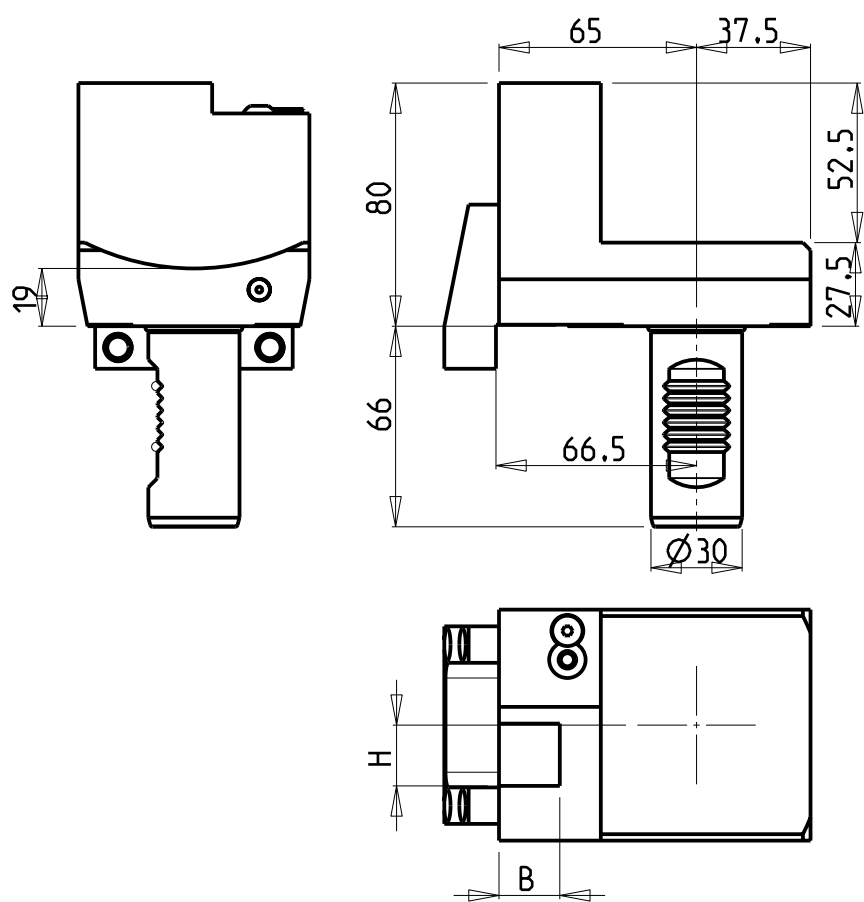

Cod. MT	Cod. MORI-SEIKI	N°Utensili N°Tools N°Werkzeuge	Misure Dimensions Masse	B	H
M0190120		1	mm	20	20
M0190119		1	Inch	3/4"	3/4"

DMG-MORI
MOD: ZT1000/1500 12/16 STAZIONI

PORTAUTENSILI RADIALE SINGOLO PER CONTROMANDRINO QD=20mm / QD=3/4"
Radial single static tool sub spindle side QD=20mm / QD=3/4"
Radial Single-werkzeughalter fuer Gegenspindel QD=20mm / QD=3/4"

Subject to change without notice.

M.T. srl

Via Casino Albini 480
Tel. 0541/956034-957884
Fax 0541/956341
47842 S. GIOVANNI IN M. (RN)
e-mail: mtma@tmarchetti.com
http://www.tmmarchetti.com



PAGINA MZT480-1-00

Ø14^{+0.15}/_{-0.10}
Utile 9

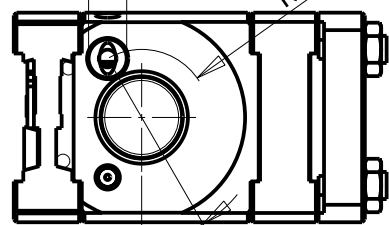

R25±0.02

POSSIBILITA' DI LAVORO M3/M4
OPTION OF M3/M4 WORKING
ARBEITSMOGLICHKEIT M3/M4

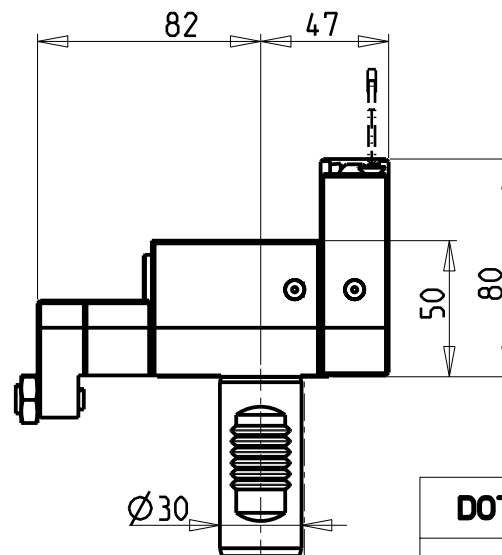
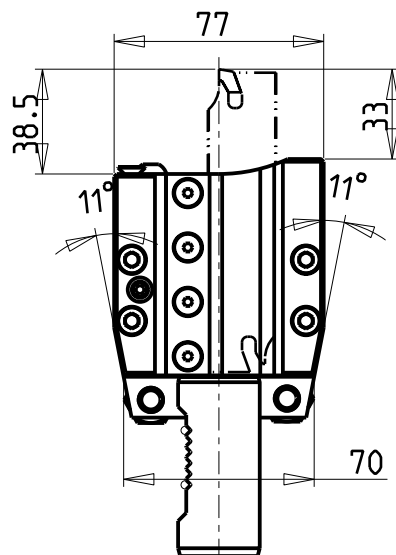
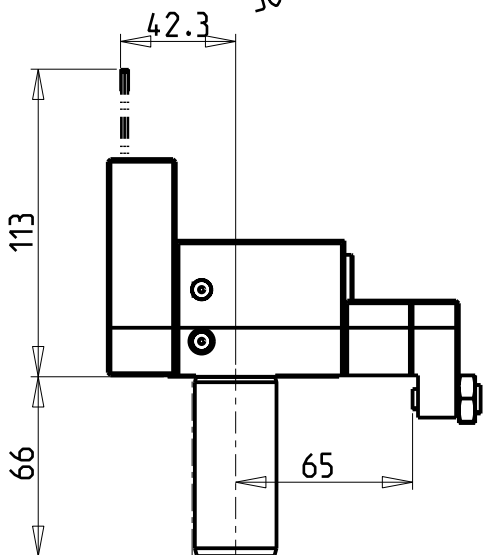
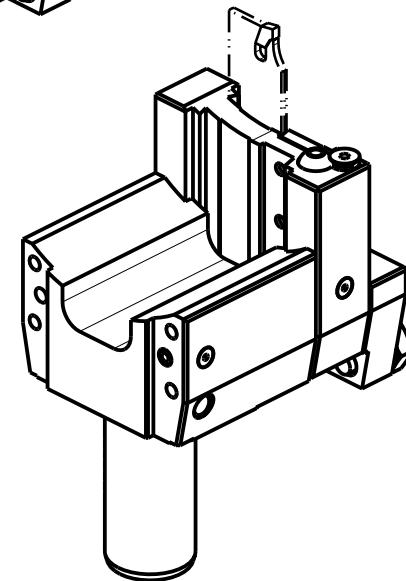
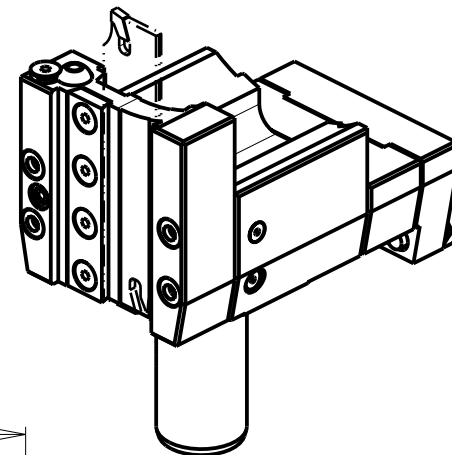

DOTAZIONI - SUPPLIED WITH - AUSSTATTUNG

- N°1 - LAMA - BLADE - KLINGE KENNAMETAL H=26 Sp. 3/4mm
- N°10 - INSERTI - INSERTS - EINLAGEN
- N°1 - CHIAVE A T PER MONTAGGIO INSERTI
- T-WRENCH FOR INSERT SET UP
- T-SCHLUESSEL FUER EINSATZSTUECK-MONTAGE

Cod. MT
N°Utensili
N°Tools
N°Werkzeuge

MZT0030126 1

DMG-MORI
MOD: ZT1000/1500 12/16 STAZIONI

PORTAUTENSILE PER LAMA DOPPIO
Radial double blade holder
Radial Doppel-Abstechhalter

Subject to change without notice.

M.T. srl

Via Casino Albini 480
Tel. 0541/956034-957884
Fax 0541/956341
47842 S. GIOVANNI IN M. (RN)
e-mail: mtma@mtmarchetti.com
http://www.mtmarchetti.com



PAGINA MZT520-1-10

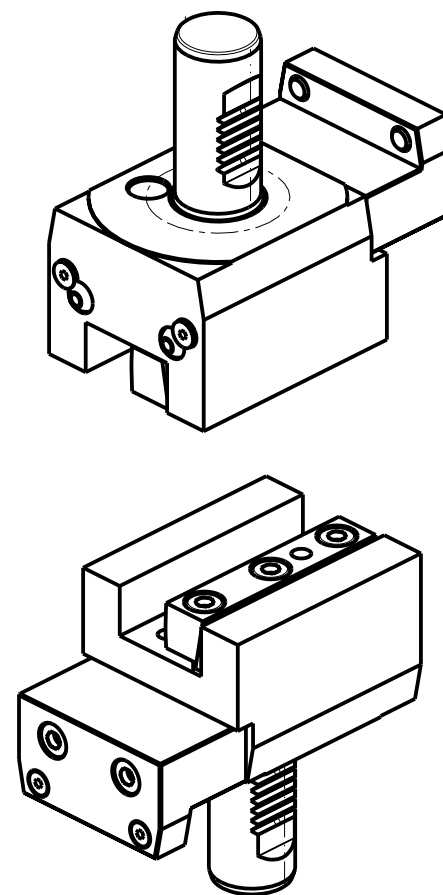
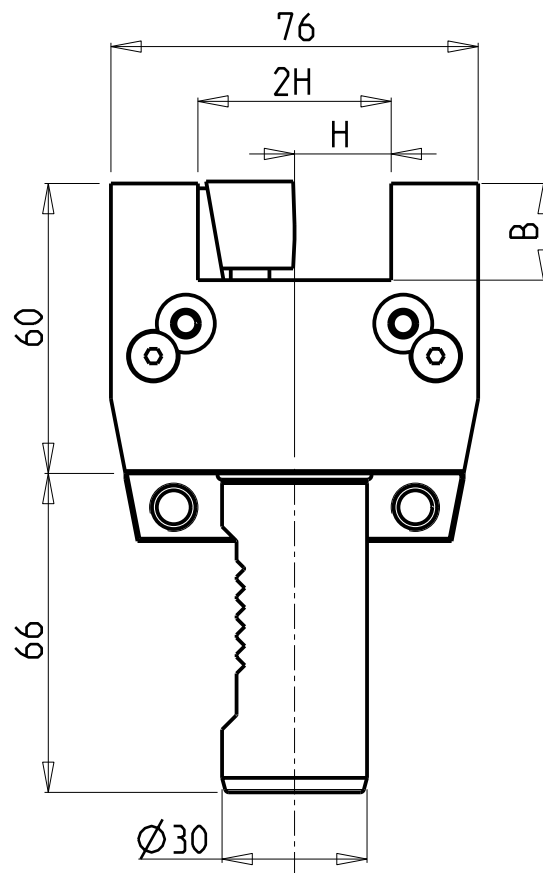
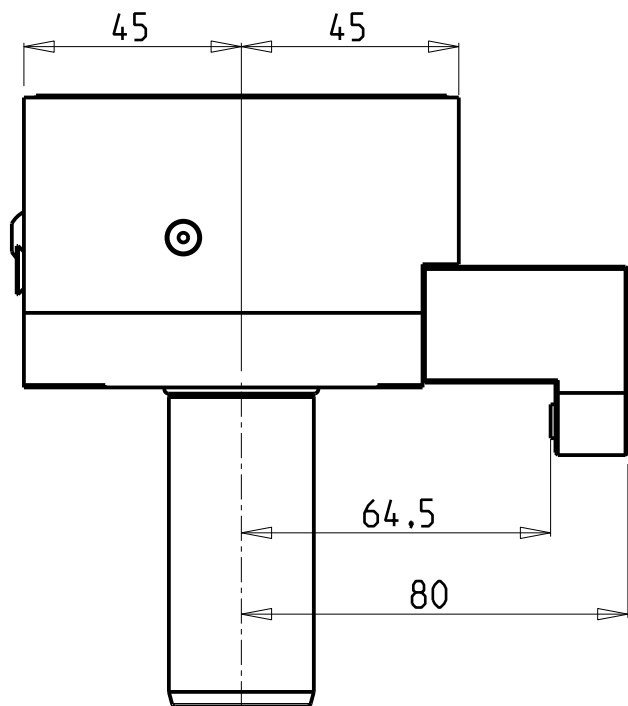

Cod. MT	Cod. MORI-SEIKI	N°Utensili N°Tools N°Werkzeuge	Misure Dimensions Masse	B	H
M0202000	T03113	1	mm	20	20
M0201905	-	1	Inch	3/4"	3/4"

DMG-MORI

MOD: ZT1000/1500 12/16 STAZIONI

PORTAUTENSILE ASSIALE SINGOLO QD=20mm / QD=3/4"

Axial single static tool QD=20mm / QD=3/4"

Axial Single-Werkzeughalter QD=20mm / QD=3/4"

Subject to change without notice.

M.T. srl

Via Casino Albini 480
Tel. 0541/956034-957884
Fax 0541/956341

47842 S. GIOVANNI IN M. (RN)
e-mail: mtma@tmarchetti.com
<http://www.tmmarchetti.com>



PAGINA MZT550-1-00

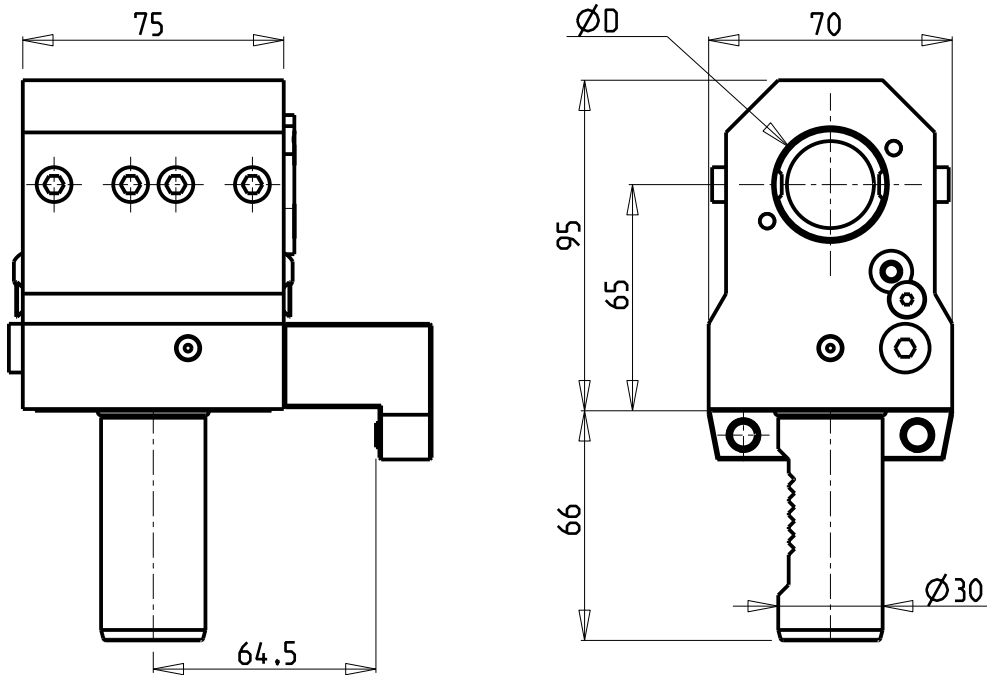

KIT ADDUZIONE INTERNA (OPZIONALE)
 KIT FOR INTERNAL COOLANT (OPTIONAL)
 KIT FUER INTERNE KUEHLMITTELZUFUHR (OPTIONAL)
 Ø32 / Ø1 1/4" cod. KIT1000001
 Ø40 cod. KIT1000003

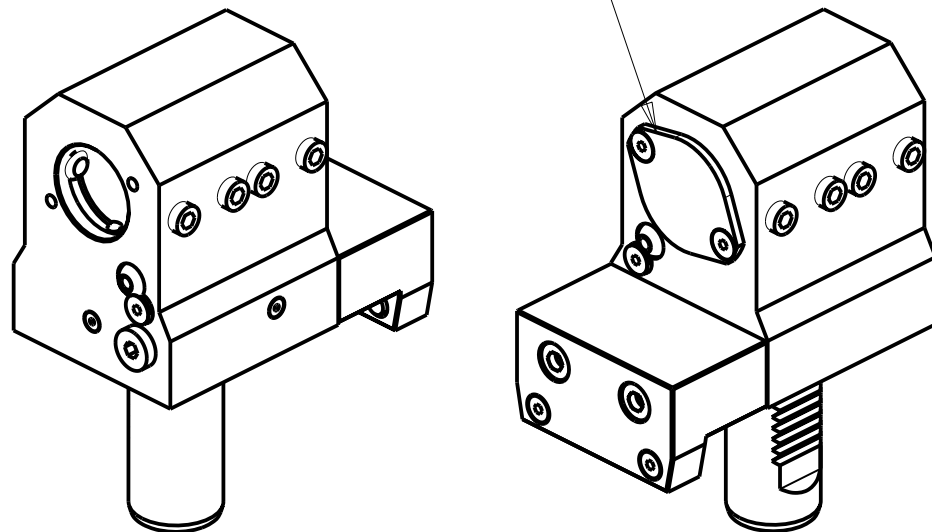

PER BOCCOLE DI RIDUZIONE VEDI PAG. TBL150-1-00
 FOR REDUCING BUSHINGS SEE PAGE TBL150-1-00
 FÜR REDUZIERBUCHSE SIEHE SEITE TBL150-1-00

Cod. MT	Cod. MORI-SEIKI	N°Utensili N°Tools N°Werkzeuge	Lubrificazione int. opzionale Coolant through optional Innenkuehlung Optional	Lubrificazione est. Ext. coolant Aussenkuehlung	Misure Dimensions Masse	D
M0163200	T15003	1	X	X	mm	32
M0163175	-	1	X	X	Inch	1 1/4"
M0164000	-	1	X	X	mm	40

DMG-MORI
 MOD: ZT1000/1500 12/16 STAZIONI

PORTAUTENSILE ASSIALE PER BARENO Ø32mm / Ø1 1/4" / Ø40mm H=65mm
 Axial single boring bar holder Ø32mm / Ø1 1/4" / Ø40mm H=65mm
 Axial Bohrhälter Ø32mm / Ø1 1/4" / Ø40mm H=65mm

Subject to change without notice.

M.T. srl

Via Casino Albini 480
 Tel. 0541/956034-957884
 Fax 0541/956341
 47842 S. GIOVANNI IN M. (RN)
 e-mail: mtma@tmarchetti.com
 http://www.tmmarchetti.com



PAGINA MZT650-1-10

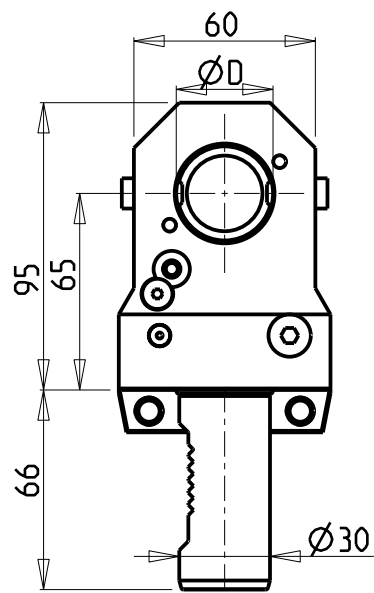
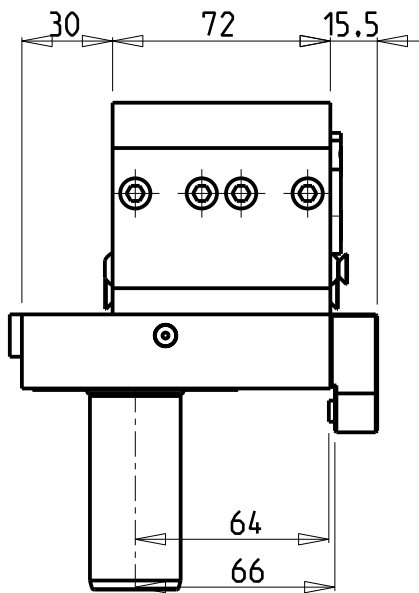

KIT ADDUZIONE INTERNA (OPZIONALE)
 KIT FOR INTERNAL COOLANT (OPTIONAL)
 KIT FUER INTERNE KUEHLMITTELZUFUHR (OPTIONAL)
 Ø32 / Ø1 1/4" cod. KIT1000001

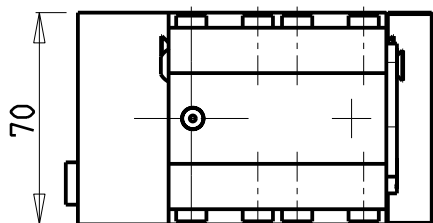
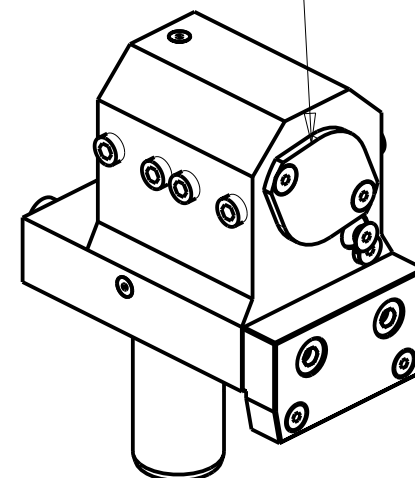
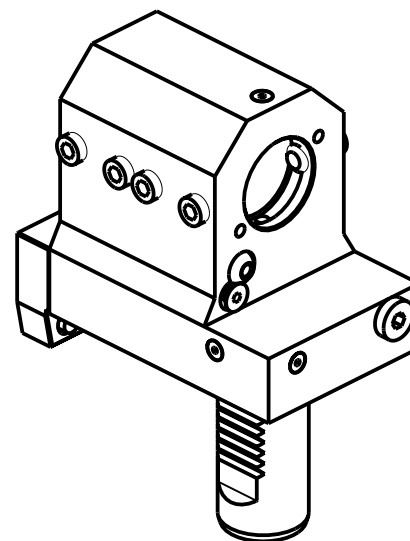

PER BOCCOLE DI RIDUZIONE VEDI PAG. TBL150-1-00
 FOR REDUCING BUSHINGS SEE PAGE TBL150-1-00
 FÜR REDUZIERBUCHSE SIEHE SEITE TBL150-1-00

Cod. MT	Cod. MORI SEIKI	N°Utensili N°Tools N°Werkzeuge	Lubrificazione int. opzionale Coolant through optional Innenkuehlung Optional	Lubrificazione est. Ext. coolant Aussenkuehlung	Misure Dimensions Masse	D
MZT0023200	-	1	X	X	mm	32
MZT0023175	-	1	X	X	Inch	1 1/4"

DMG-MORI
 MOD: ZT1000/1500 12/16 STAZIONI

PORTABARENO ARRETR. LATO MANDRINO. PROLUNGATO LATO CONTROMAND. Ø32mm / Ø1 1/4" H=65mm
 Rear-set boring bar holder on main spindle side, extended on subspindle side
 Bohrhälter zurueckversezt auf Hauptspindel-seite, verlaengert auf Gegenspindel-seite

Subject to change without notice.

M.T. srl
 Via Casino Albini 480
 Tel. 0541/956034-957884
 Fax 0541/956341
 47842 S. GIOVANNI IN M. (RN)
 e-mail: mtma@mtmarchetti.com
 http://www.mtmarchetti.com



PAGINA MZT850-1-00

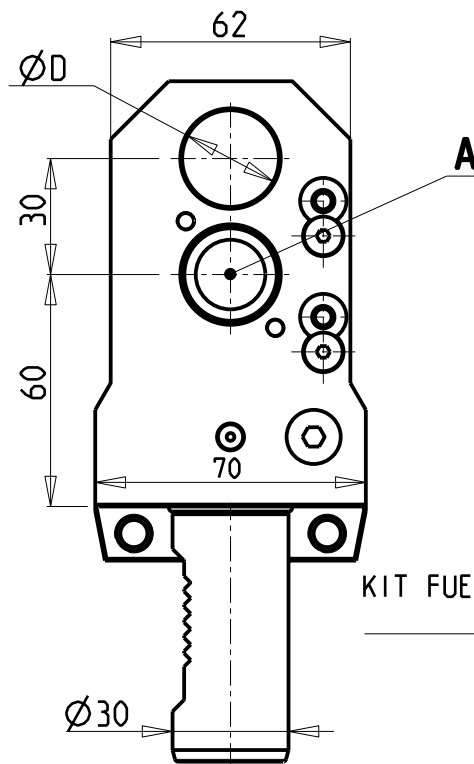
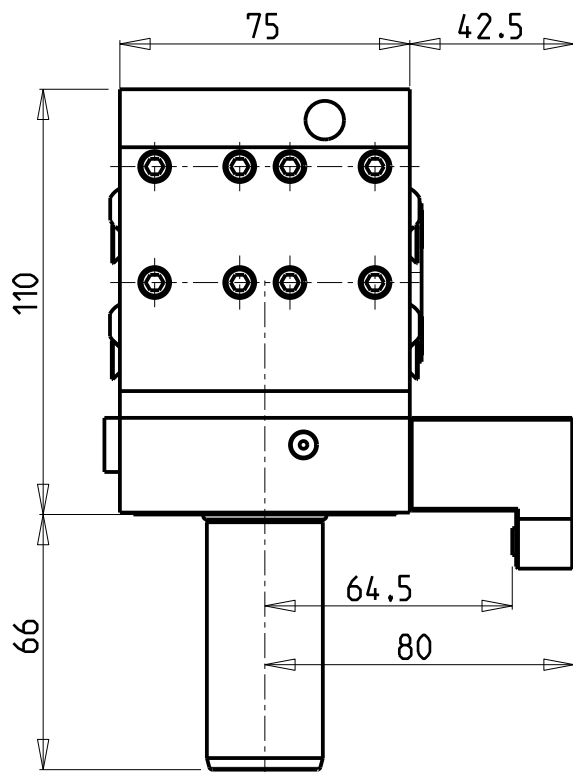

KIT ADDUZIONE INTERNA (OPZIONALE)
 KIT FOR INTERNAL COOLANT (OPTIONAL)
 KIT FUER INTERNE KUEHLMITTELZUFUHR (OPTIONAL)
 cod. KIT1000006

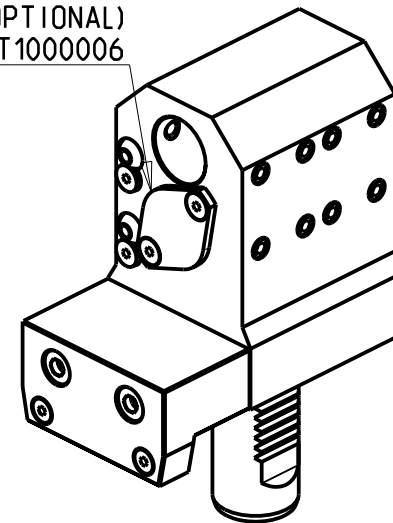
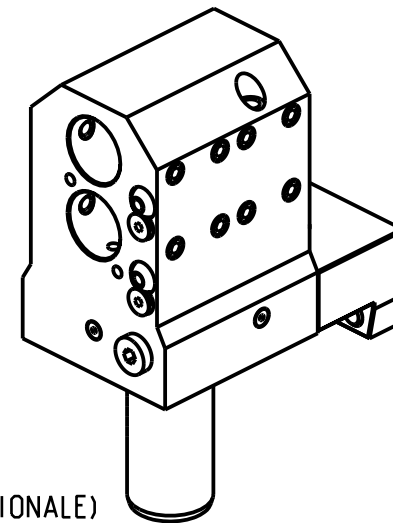

PER BOCCOLE DI RIDUZIONE VEDI PAG. TBL150-1-00
 FOR REDUCING BUSHINGS SEE PAGE TBL150-1-00
 FÜR REDUZIERBUCHSE SIEHE SEITE TBL150-1-00

Cod. MT	Cod. MORI-SEIKI	N°Utensili N°Tools N°Werkzeuge	A Lubrificazione int. solo foro A Coolant through hole A only Innenkuehlung nur loch A	Lubrificazione est. opzionale Ext. coolant optional Aussenkuehlung Optional	Misure Dimensions Masse	D
M0212500	-	2	X	X	mm	25
M0212540	-	2	X	X	Inch	1"

DMG-MORI
 MOD: ZT1000/1500 12/16 STAZIONI

PORTAUTENSILE ASSIALE PER BARENO 2 POSIZIONI Ø25mm / Ø1"
 Axial double boring bar holder Ø25mm / Ø1"
 Axial Bohrhälter 2 Positionen Ø25mm / Ø1"

Subject to change without notice.

M.T. srl
 Via Casino Albini 480
 Tel. 0541/956034-957884
 Fax 0541/956341
 47842 S. GIOVANNI IN M. (RN)
 e-mail: mtma@mtmarchetti.com
 http://www.mtmarchetti.com



PAGINA MZT864-1-00

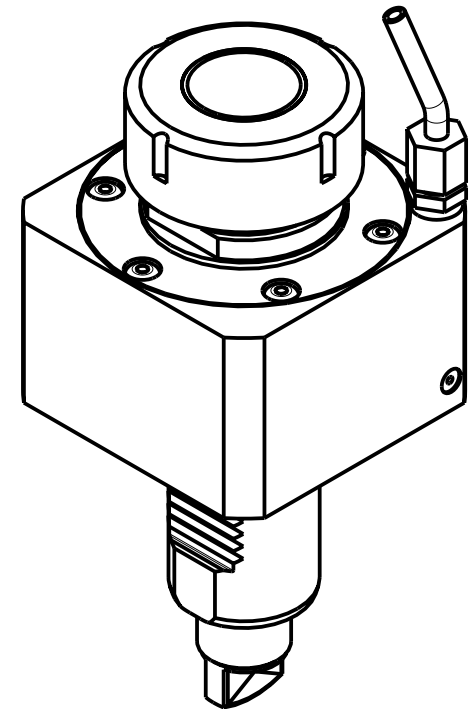
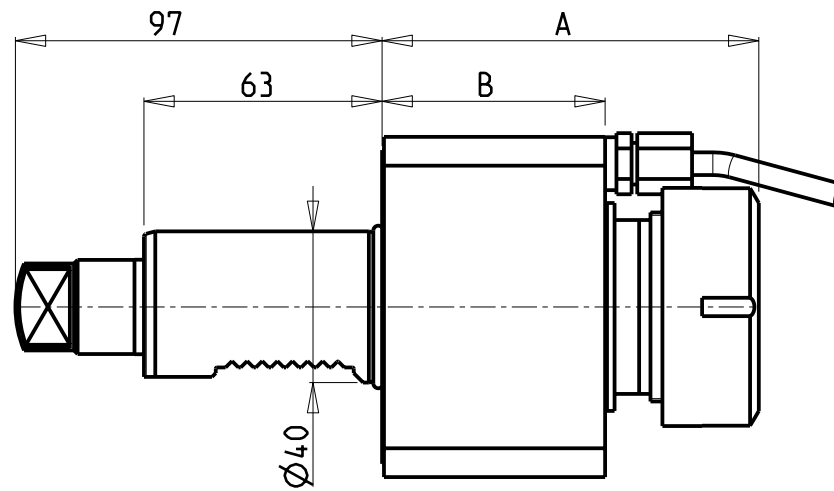
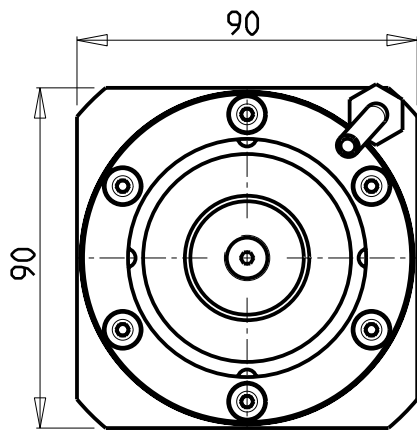

Cod. MT	Mandrino Spindle Spindel	I	RPM	Coppia Max Max Torque Max Drehmoment	Lubrificazione int. Coolant through Innenkühlung	Lubrificazione est. Ext. coolant Aussenkühlung	A	B	CHIAVI NON INCLUSE Keys not included Schlüssel nicht einbegriffen	
MMT0020140	ER40	1:1	6000	70Nm		X	99.66	59	CHUB46	CHSTER40
MMT0020240	ER40	1:1	6000	70Nm	P=30bar	X	112.66	72	CHUB46	CHSTER40

DMG-MORI
MOD: MT2000/2500 - ZT2500

MODULO MOTORIZZATO RADIALE
Radial driven tool
Radial angetriebenes Werkzeug

Subject to change without notice.

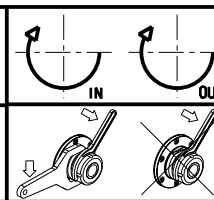

M.T. srl
Via Casino Albini 480
Tel. 0541/956034-957884
Fax 0541/956341
47842 S. GIOVANNI IN M. (RN)
e-mail: mtma@tmarchetti.com
http://www.tmmarchetti.com



PAGINA MZT010-2-00

ATTENZIONE - ATTENTION - ACHTUNG

- Per lo smontaggio degli utensili utilizzare sempre la chiave di contrasto come indicato nel manuale d'uso.
- For disassembly of the tools use always the contrast key as mentioned in the user instructions.
- Fuer das Abmontieren der Werkzeuge immer den Gegenschlüssel benutzen wie in der Bedienungsanleitung erwaeht.

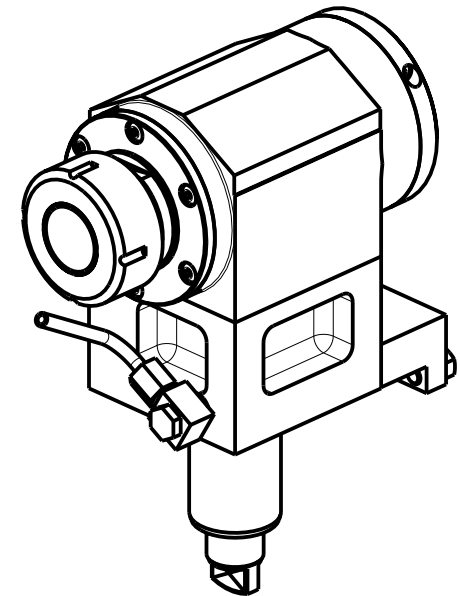
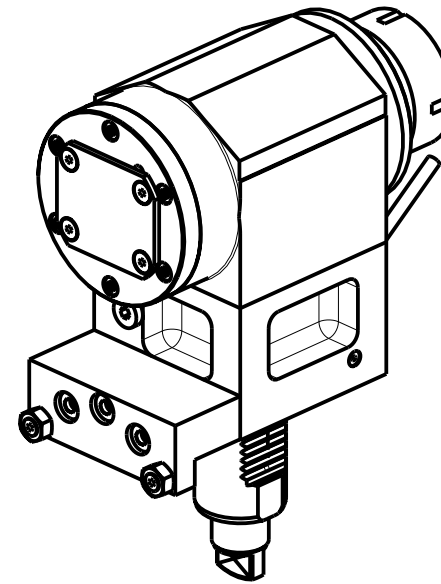
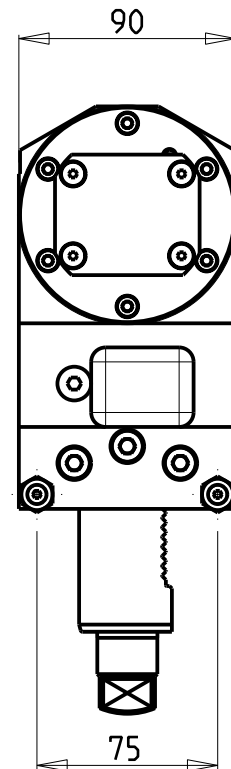
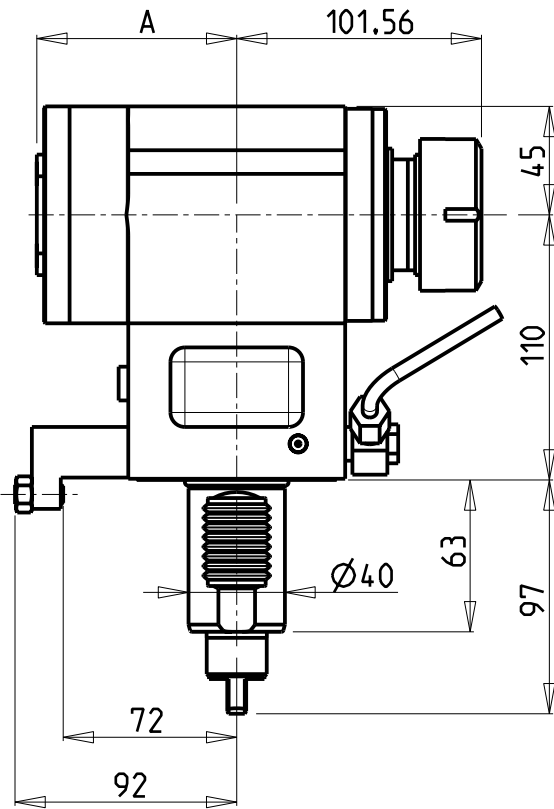

Cod. MT	Mandrino Spindle Spindel	I	RPM	Coppia Max Max Torque Max Drehmoment	Lubrificazione int. Coolant through Innenkuehlung	Lubrificazione est. Ext. coolant Aussenkuehlung	A	CHIAVI NON INCLUSE Keys not included Schlüssel nicht einbegriffen	
MMT0010140	ER40	1:1	6000	70Nm		X	82.95	CHUB46	CHSTER40
MMT0010340	ER40	1:1	6000	70Nm	P=70bar	X	106.45	CHUB46	CHSTER40

DMG-MORI
MOD: MT2000/2500 - ZT2500

MODULO MOTORIZZATO ASSIALE
Axial driven tool
Axial angetriebenes Werkzeug

Subject to change without notice.

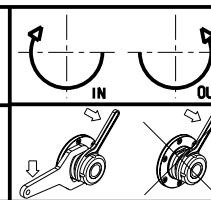

M.T. srl
Via Casino Albini 480
Tel. 0541/956034-957884
Fax 0541/956341
47842 S. GIOVANNI IN M. (RN)
e-mail: mtma@mtmarchetti.com
http://www.mtmarchetti.com



PAGINA MZT150-2-10

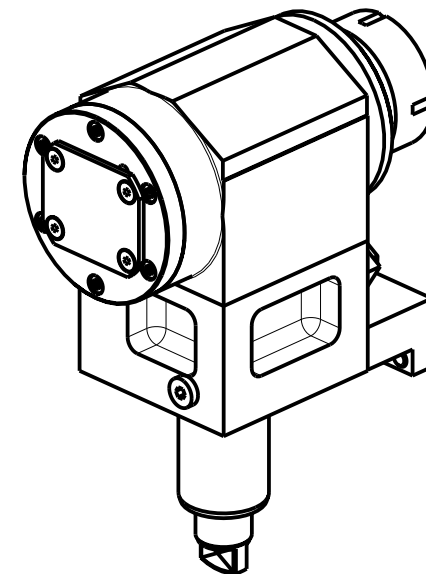
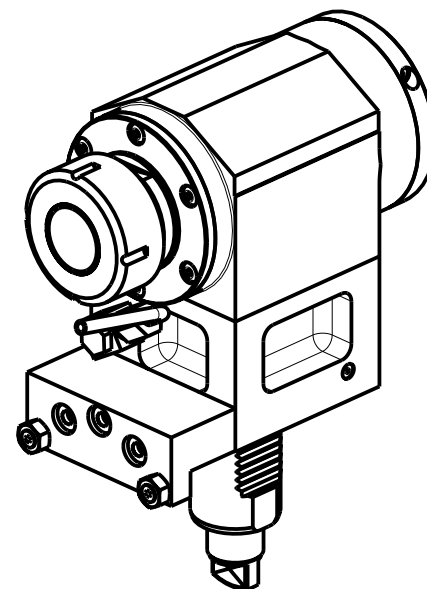
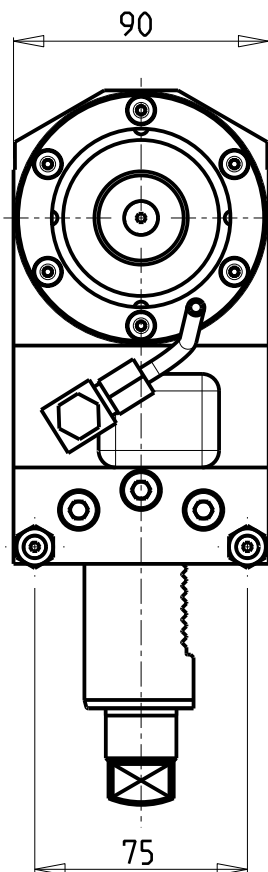
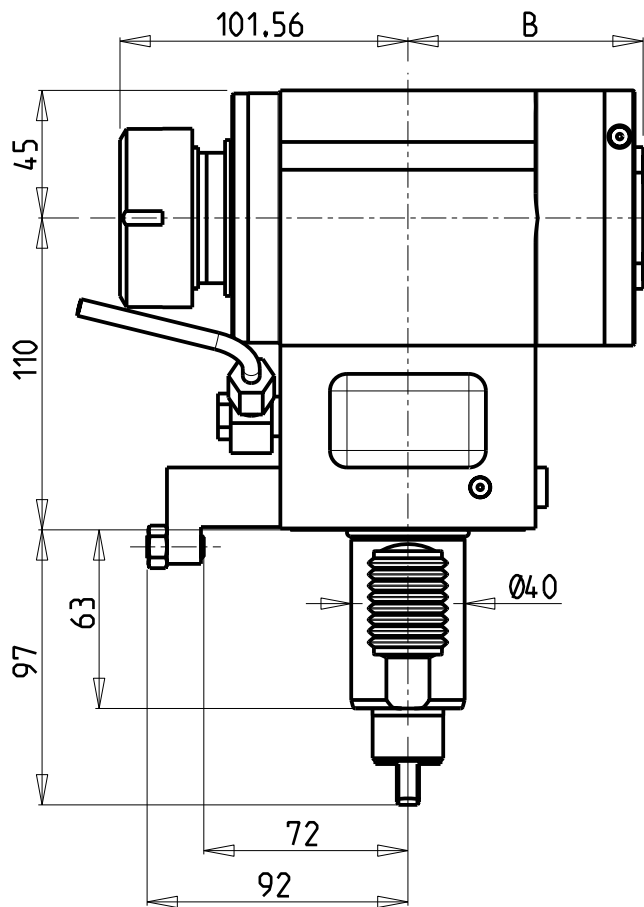

ATTENZIONE - ATTENTION - ACHTUNG

- Per lo smontaggio degli utensili utilizzare sempre la chiave di contrasto come indicato nel manuale d'uso.
- For disassembly of the tools use always the contrast key as mentioned in the user instructions.
- Fuer das Abmontieren der Werkzeuge immer den Gegenschlüssel benutzen wie in der Bedienungsanleitung erwäehnt.

Cod. MT	Mandrino Spindle Spindel	I	RPM	Coppia Max Max Torque Max Drehmoment	Lubrificazione int. Coolant through Innenkuehlung	Lubrificazione est. Ext. coolant Aussenkuehlung	B	CHIAVI NON INCLUSE Keys not included Schluesssel nicht einbegriffen	
								CHUB46	CHSTER40
MMT0011040	ER40	1:1	6000	70Nm		X	82.95	CHUB46	CHSTER40
MMT0011140	ER40	1:1	6000	70Nm	P=70bar	X	106.45	CHUB46	CHSTER40

DMG-MORI
MOD: MT2000/2500 - ZT2500

MODULO MOTORIZZATO ASSIALE PER CONTROMANDRINO
Axial driven tool sub spindle side
Axial angetriebenes Werkzeug fuer Gegenspindel

Subject to change without notice.

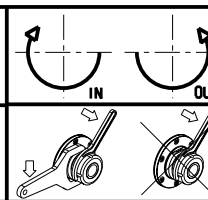

M.T. srl
Via Casino Albini 480
Tel. 0541/956034-957884
Fax 0541/956341
47842 S. GIOVANNI IN M. (RN)
e-mail: mtma@mtmarchetti.com
http://www.mtmarchetti.com



PAGINA MZT155-2-10

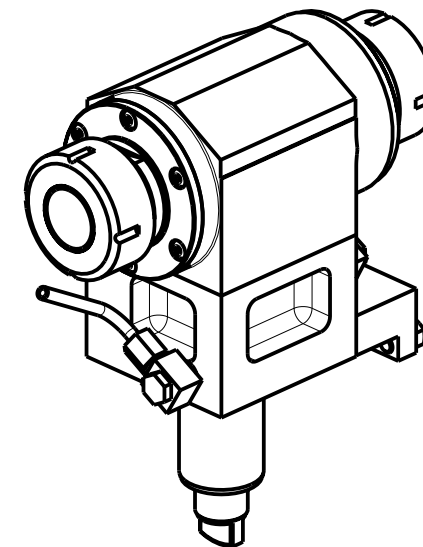
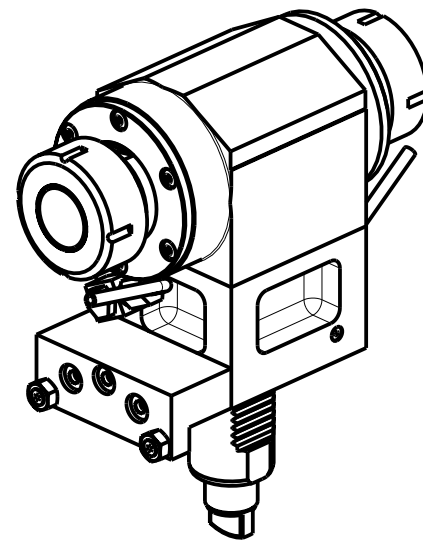
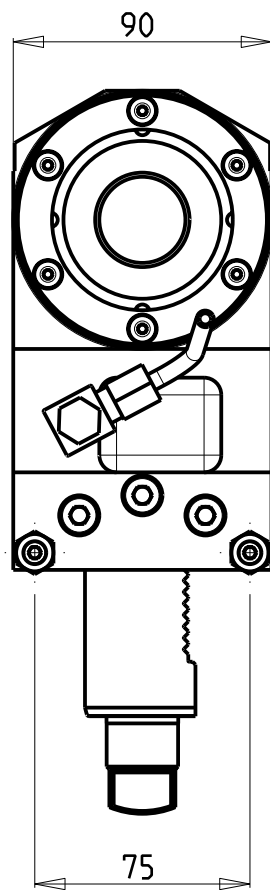
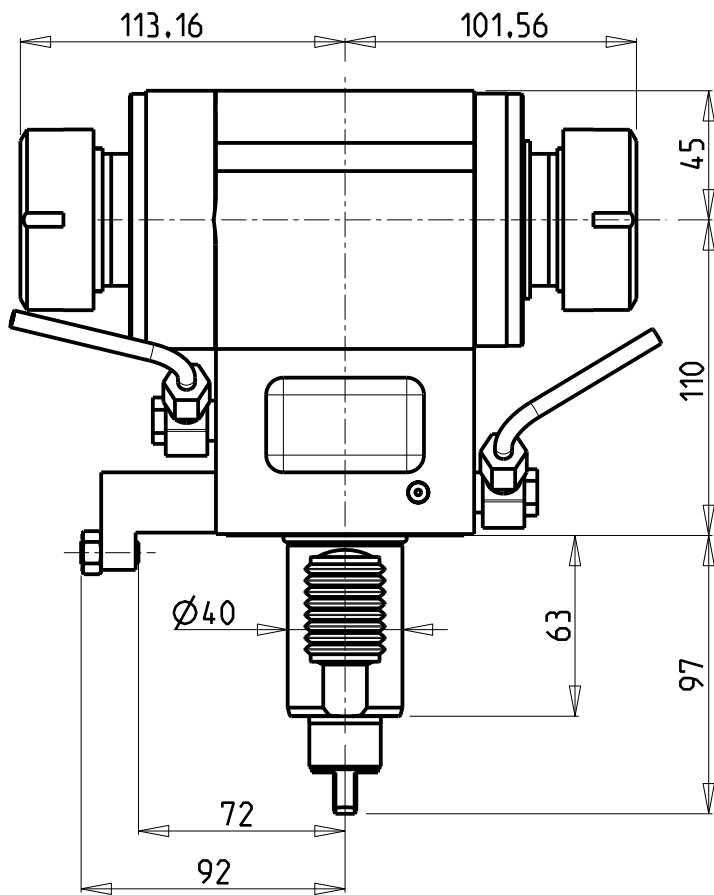

ATTENZIONE - ATTENTION - ACHTUNG

- Per lo smontaggio degli utensili utilizzare sempre la chiave di contrasto come indicato nel manuale d'uso.
- For disassembly of the tools use always the contrast key as mentioned in the user instructions.
- Fuer das Abmontieren der Werkzeuge immer den Gegenschlüssel benutzen wie in der Bedienungsanleitung erwaeht.

Cod. MT	Mandrino Spindle Spindel	I	RPM	Coppia Max Max Torque Max Drehmoment	Lubrificazione est. Ext. coolant Aussenkuehlung	CHIAVI NON INCLUSE Keys not included Schluesssel nicht einbegriffen	
MMT0010240	ER40+ER40	1:1	6000	70Nm	X	CHUB46	CHSTER40

DMG-MORI
MOD: MT2000/2500 - ZT2500

MODULO MOTORIZZATO ASSIALE BISPORGENTE
Axial opposite face driven tool
Axial angetriebenes Werkzeug halb vorspringend

Subject to change without notice.

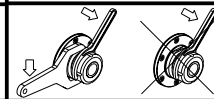

M.T. srl
Via Casino Albini 480
Tel. 0541/956034-957884
Fax 0541/956341
47842 S. GIOVANNI IN M. (RN)
e-mail: mtma@mtmarchetti.com
http://www.mtmarchetti.com

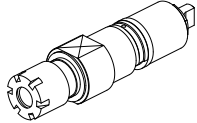
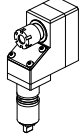
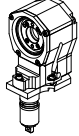

PAGINA MZT240-2-10

		PAGINA Page Seite
<p>MODULO MOTORIZZATO RADIALE Radial driven tool Radial angetriebenes Werkzeug</p>		SPR010.1.00
<p>MODULO MOTORIZZATO ASSIALE ARRETRATO Axial rear-set driven tool Axial angetriebenes Werkzeug zurueckversetzt</p>		SPR180.1.20
<p>MODULO MOTORIZZATO TURBINATORE RIDOTTO I=2:1 Driven whirling tool geared-down I=2:1 Gewindewirbeleinrichtung untersetzt I=2:1</p>		SPR370.1.00

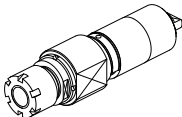
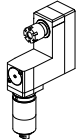
		PAGINA Page Seite
MODULO MOTORIZZATO RADIALE Radial driven tool Radial angetriebenes Werkzeug		SPR010.2.00
MODULO MOTORIZZATO ASSIALE ARRETRATO Axial rear-set driven tool Axial angetriebenes Werkzeug zurueckversetzt		SPR180.2.10

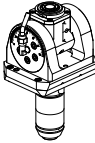
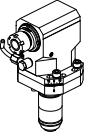
		PAGINA Page Seite
MODULO MOTORIZZATO ORIENTABILE $\pm 90^\circ$ $\pm 90^\circ$ adjustable angle driven tool Angetriebenes Werkzeug schwenkbar $\pm 90^\circ$		SPR335.3.00
MODULO MOTORIZZATO ASSIALE ANGOLARE $\pm 15^\circ$ Axial adjustable angle $\pm 15^\circ$ driven tool Axial angetriebenes Werkzeug schwenkbar $\pm 15^\circ$		SPR355.3.00

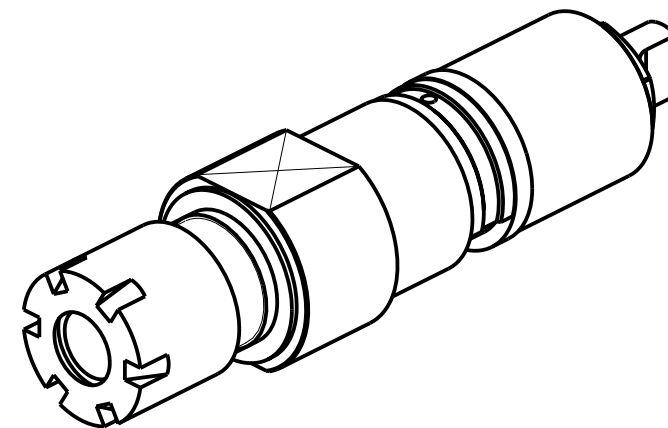
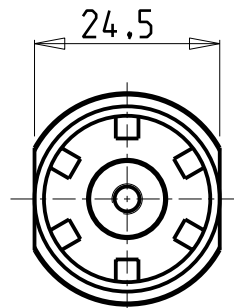
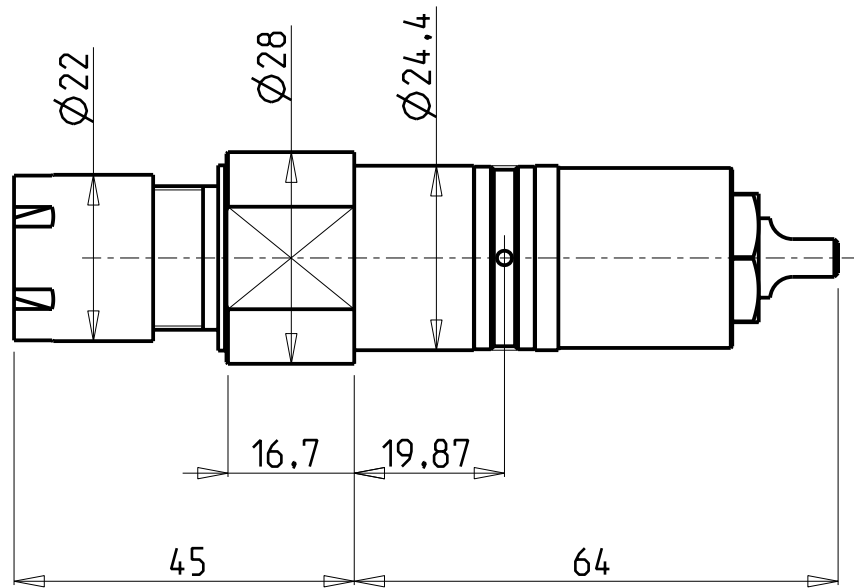

Cod. MT	Mandrino Spindle Spindel	I	RPM	Lubr.esterna Ext. coolant Aussenkuehlung	CHIAVI NON INCLUDE Keys not included Schluessel nicht einbegriffen
SPC1621000	ER16	1:1	6000	X	CHMNER16

DMG-MORI
SPRINT 20/5 - SPRINT 20/8

MODULO MOTORIZZATO RADIALE
Radial driven tool
Radial angetriebenes Werkzeug

Subject to change without notice.

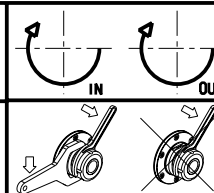

M.T. srl
Via Casino Albini 480
Tel. 0541/956034-957884
Fax 0541/956341
47842 S. GIOVANNI IN M. (RN)
e-mail: mtma@mtmarchetti.com
http://www.mtmarchetti.com



PAGINA SPR010-1-00

ATTENZIONE - ATTENTION - ACHTUNG

- Solo per mandrino principale
- Only for main spindle
- Nur für Hauptspindel

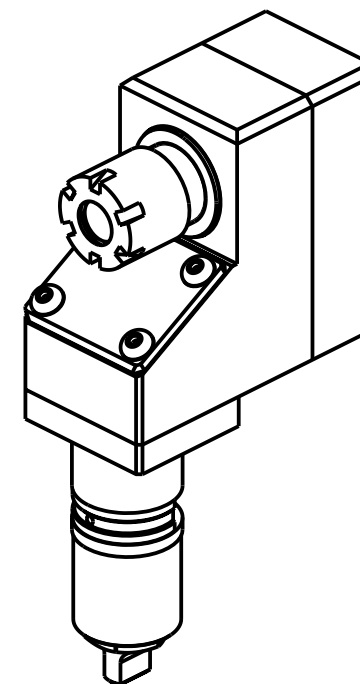
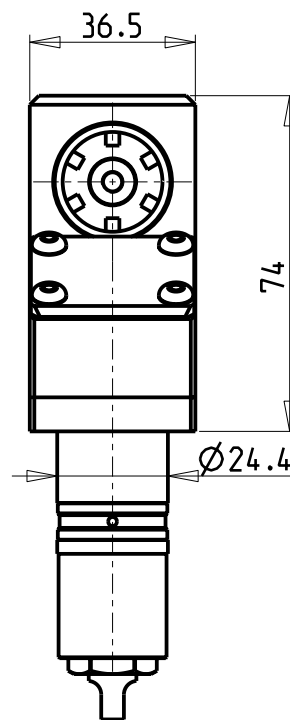
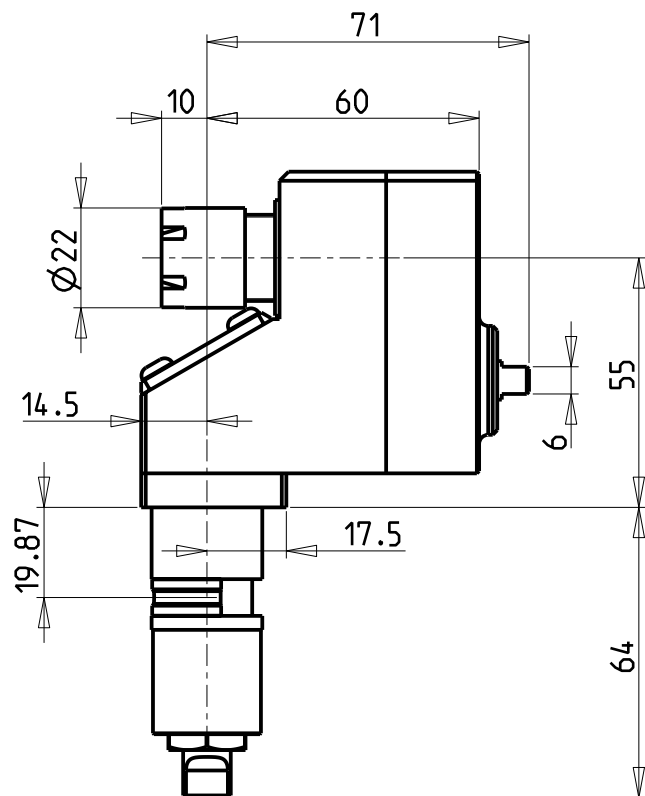

Cod. MT	Mandrino Spindel Spindel	I	RPM	Lubr.esterna Ext. coolant Aussenkuehlung	CHIAVI NON INCLUDE Keys not included Schluessel nicht einbegriffen
SPC0891000	ER16	1:1	6000	X	CHMNER16

DMG-MORI
SPRINT 20/5 - SPRINT 20/8

MODULO MOTORIZZATO ASSIALE ARRETRATO

Axial rear-set driven tool

Axial angetriebenes Werkzeug zurueckversetzt

Subject to change without notice.

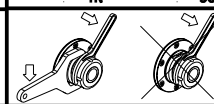
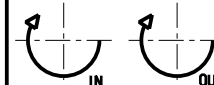

M.T. srl

Via Casino Albini 480
Tel. 0541/956034-957884
Fax 0541/956341

47842 S. GIOVANNI IN M. (RN)
e-mail: mtma@mtmarchetti.com
http://www.mtmarchetti.com



PAGINA SPR180-1-20

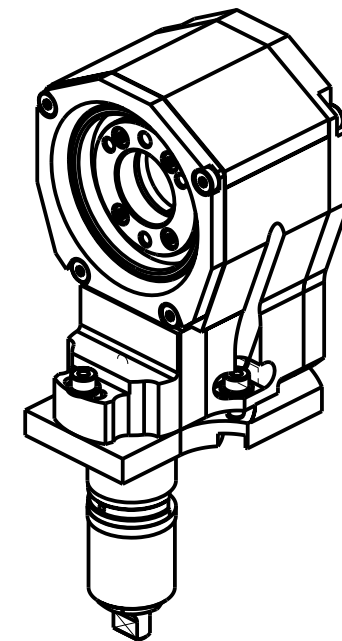
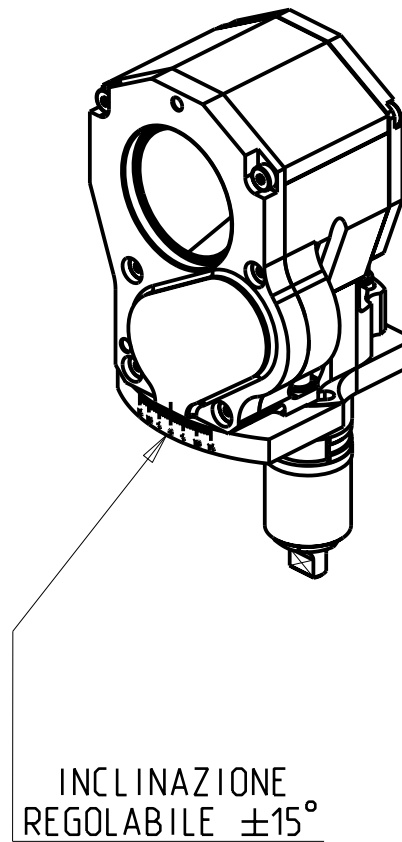
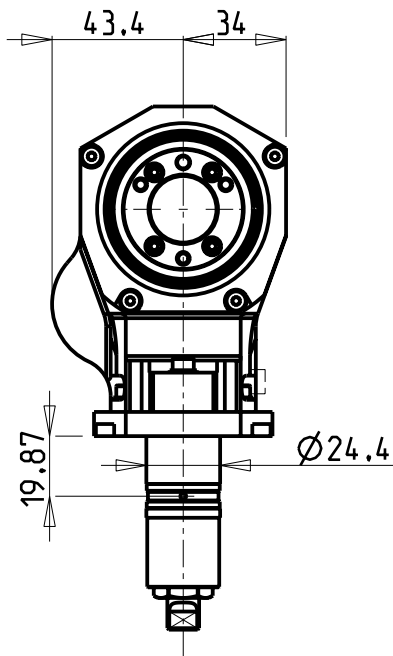
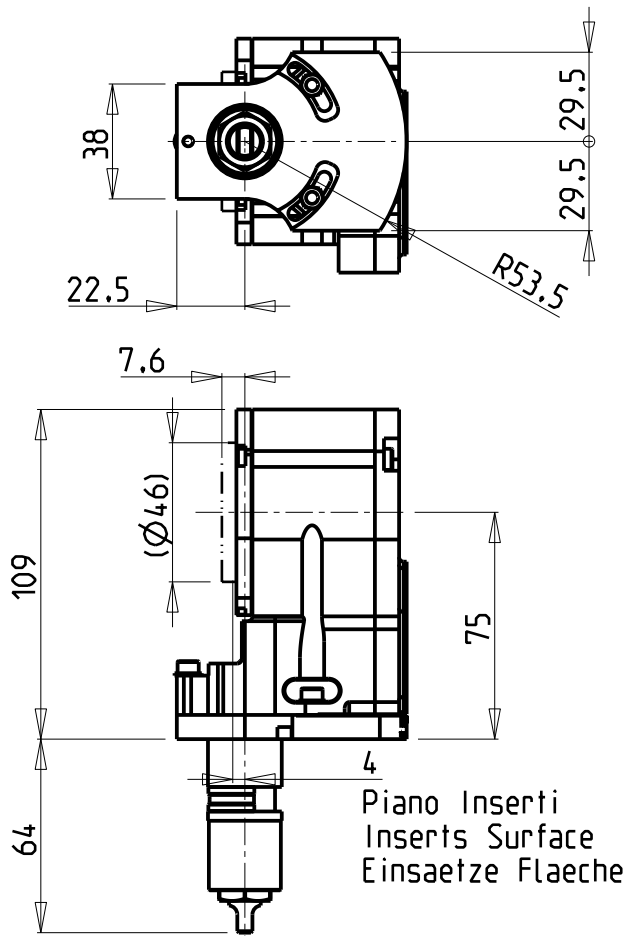

Cod. MT	I	RPM	Lubrificazione est. Ext. coolant Aussenkuehlung
SPC 1921000	2:1	3000	X

Fresa non inclusa:
Milling-cutter not included:
Fraese nicht inbegriffen:
SANDVIK Coromill 325 cod. 325-12AP40-16M

DMG-MORI
SPRINT 20/8

MODULO MOTORIZZATO TURBINATORE RIDOTTO I=2:1
Driven whirling tool geared-down I=2:1
Gewindewirbeleinrichtung untersetzt I=2:1

Subject to change without notice.

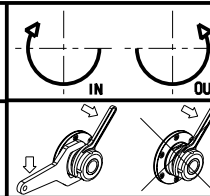

M.T. srl
Via Casino Albini 480
Tel. 0541/956034-957884
Fax 0541/956341
47842 S. GIOVANNI IN M. (RN)
e-mail: mtma@mtmarchetti.com
http://www.mtmarchetti.com



PAGINA SPR370-1-00

ATTENZIONE - ATTENTION - ACHTUNG

- Per lo smontaggio degli utensili utilizzare sempre la chiave di contrasto come indicato nel manuale d'uso.
- For disassembly of the tools use always the contrast key as mentioned in the user instructions.
- Fuer das Abmontieren der Werkzeuge immer den Gegenschlüssel benutzen wie in der Bedienungsanleitung erwaeht.

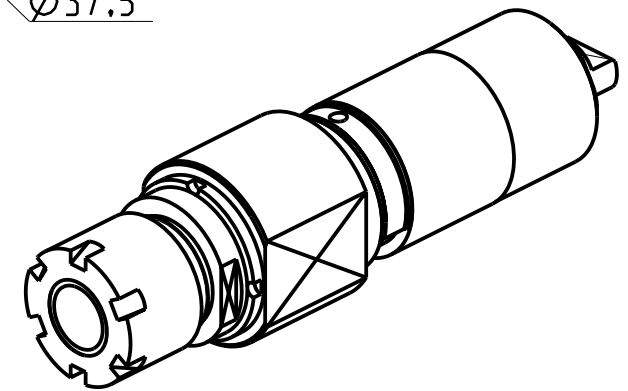
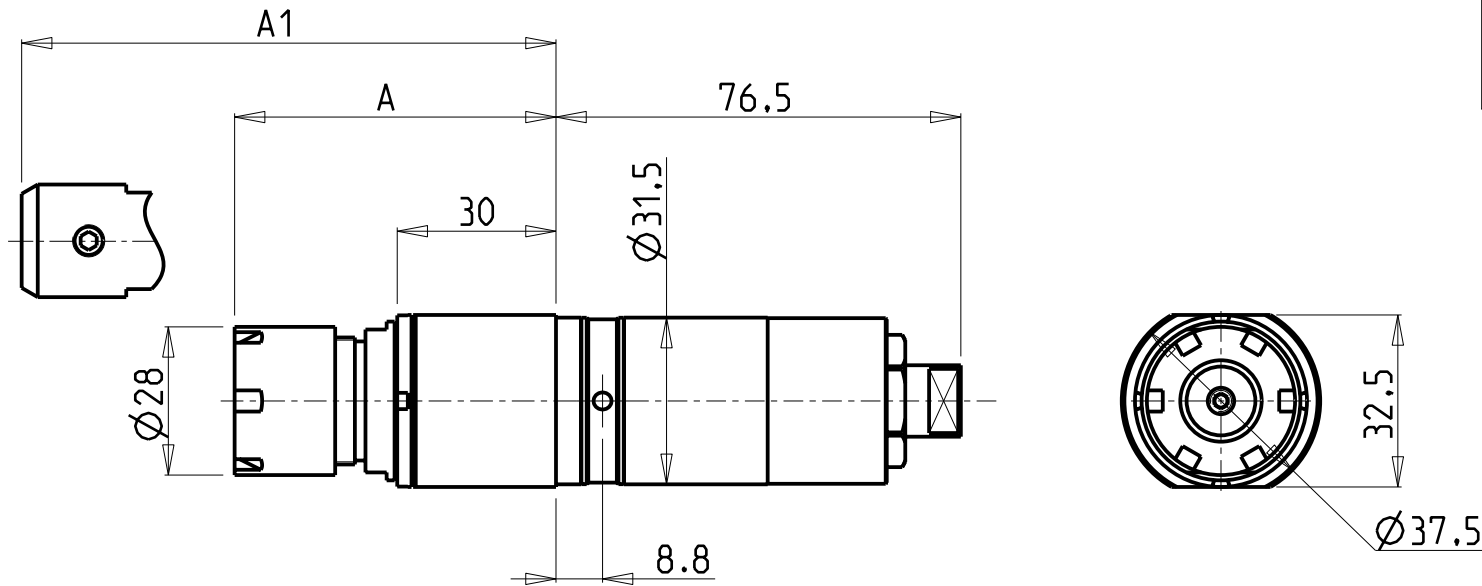

Cod. MT	Mandrino Spindle Spindel	I	RPM	Lubr.esterna Ext. coolant Aussenkuehlung	A	A1	CHIAVI NON INCLUSE Keys not included Schlüssel nicht einbegriffen	
GDM0010120	ER20	1:1	6000	X	60.7	-	CHMNER20	CHUB27_SP3
GDM0010716	WELDON 16	1:1	6000	X	-	55	-	CHUB27_SP3

DMG-MORI
SPRINT 32/42 LINEAR - SPRINT 42/10 LINEAR

MODULO MOTORIZZATO RADIALE
Radial driven tool
Radial angetriebenes Werkzeug

Subject to change without notice.

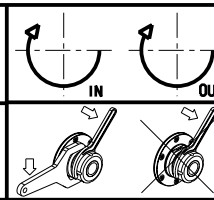

M.T. srl
Via Casino Albini 480
Tel. 0541/956034-957884
Fax 0541/956341
47842 S. GIOVANNI IN M. (RN)
e-mail: mtma@mtmarchetti.com
http://www.mtmarchetti.com



PAGINA SPR010-2-00

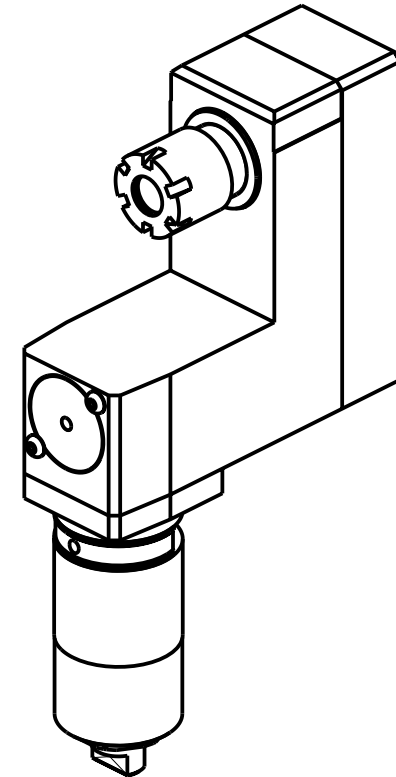
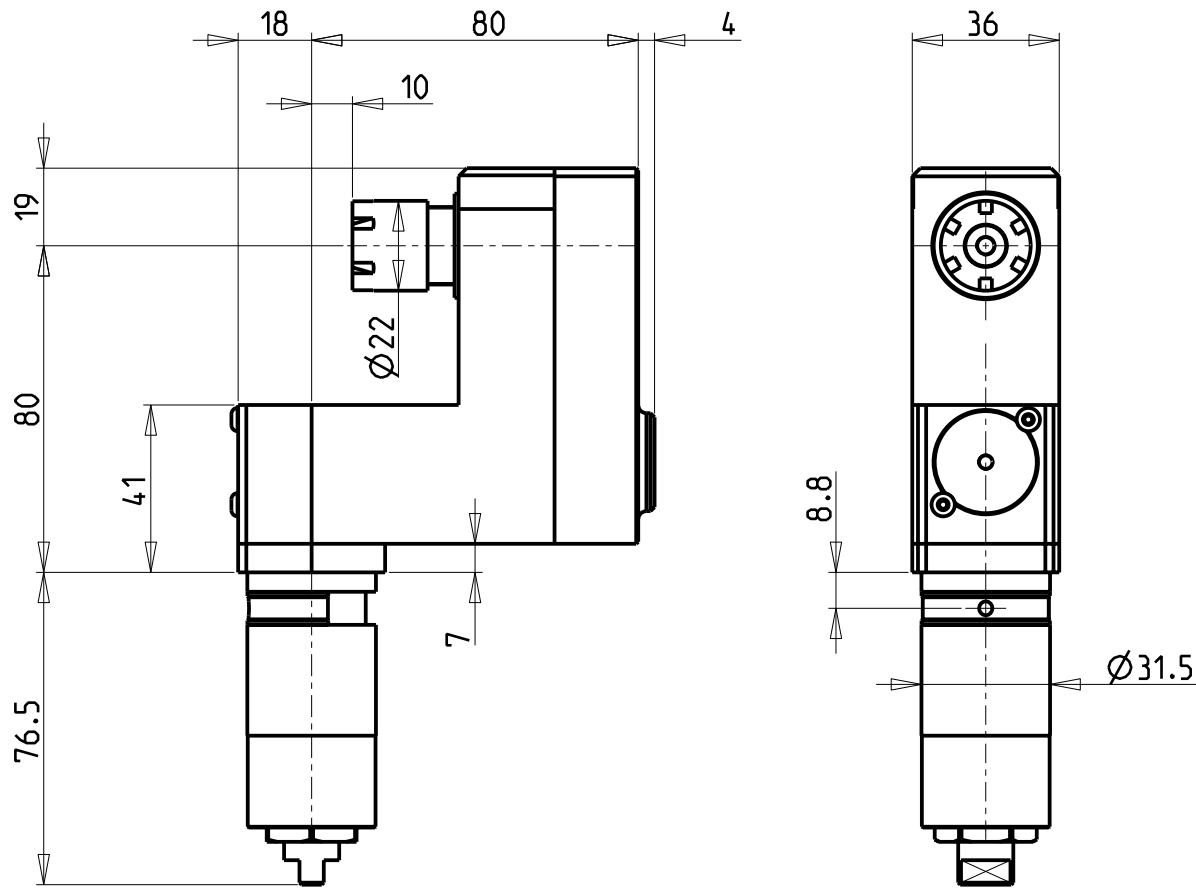

Cod. MT	Mandrino Spindel Spindel	I	RPM	Lubr.esterna Ext. coolant Aussenkuehlung	CHIAVI NON INCLUDE Keys not included Schluessel nicht einbegriffen
SPC2111000	ER16	1:1	6000	X	CHMNER16

DMG-MORI
SPRINT 42/10 LINEAR

MODULO MOTORIZZATO ASSIALE ARRETRATO
Axial rear-set driven tool
Axial angetriebenes Werkzeug zurueckversetzt

Subject to change without notice.

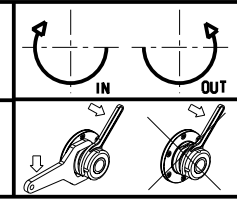

M.T. srl
Via Casino Albini 480
Tel. 0541/956034-957884
Fax 0541/956341
47842 S. GIOVANNI IN M. (RN)
e-mail: mtma@mtmarchetti.com
http://www.mtmarchetti.com



PAGINA SPR180-2-10

ATTENZIONE - ATTENTION - ACHTUNG

- Per lo smontaggio degli utensili utilizzare sempre la chiave di contrasto come indicato nel manuale d'uso.
- For disassembly of the tools use always the contrast key as mentioned in the user instructions.
- Fuer das Abmontieren der Werkzeuge immer den Gegenschlüssel benutzen wie in der Bedienungsanleitung erwaeht.

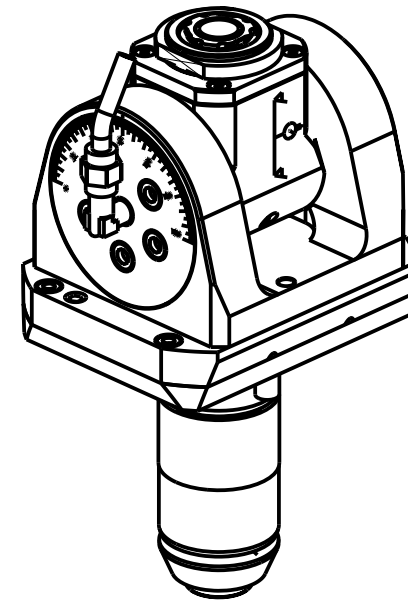
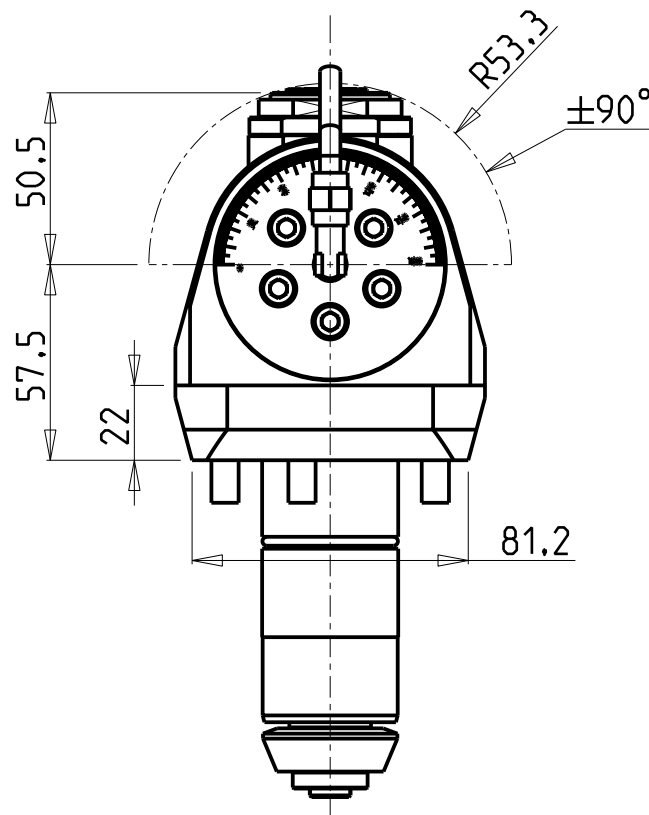
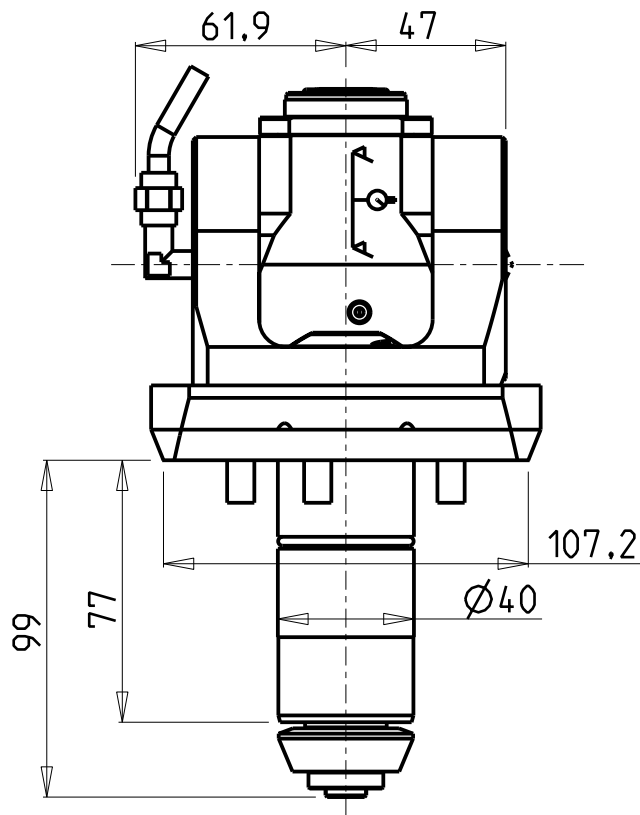

Cod. MT	Mandrino Spindle Spindel	I	RPM	Lubrificazione est. Ext. coolant Aussenkuehlung	CHIAVI INCLUSE Keys included Schluesssel inbegriffen		
					CHUB36	CHUB22	CHTAER20ZC
GDM0020120	ERA20	1:1	5000	X			

DMG-MORI
SPRINT 42/10 LINEAR (8/16ST. TURRET)

MODULO MOTORIZZATO ORIENTABILE ±90°
±90° adjustable angle driven tool
Angetriebenes Werkzeug schwenkbar ±90°

Subject to change without notice.

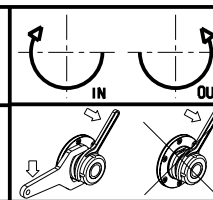

M.T. srl
Via Casino Albini 480
Tel. 0541/956034-957884
Fax 0541/956341
47842 S. GIOVANNI IN M. (RN)
e-mail: mtma@mtmarchetti.com
http://www.mtmarchetti.com



PAGINA SPR335-3-00

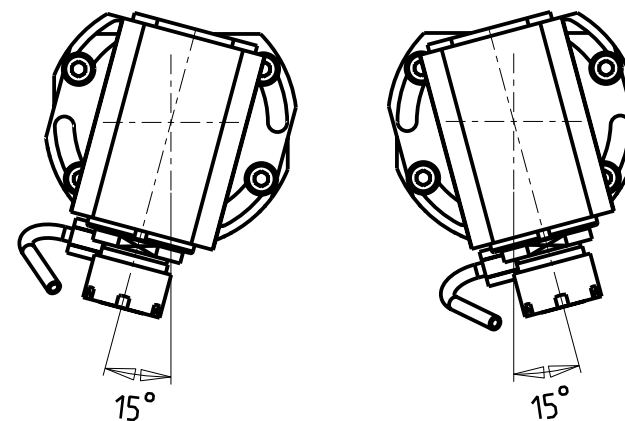
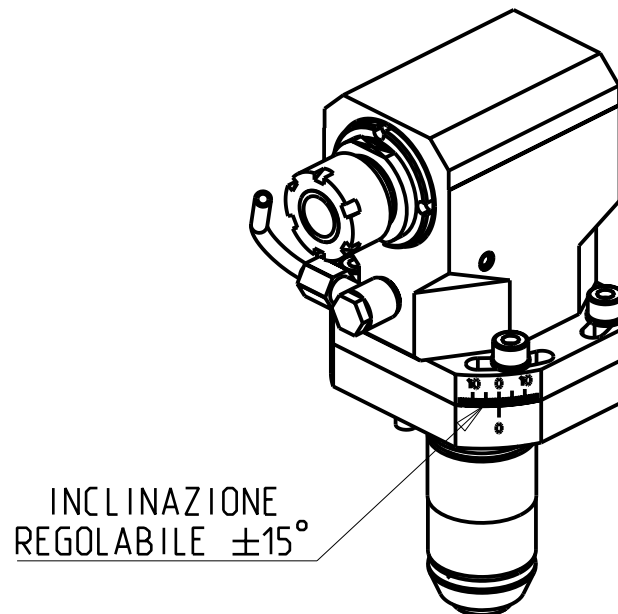
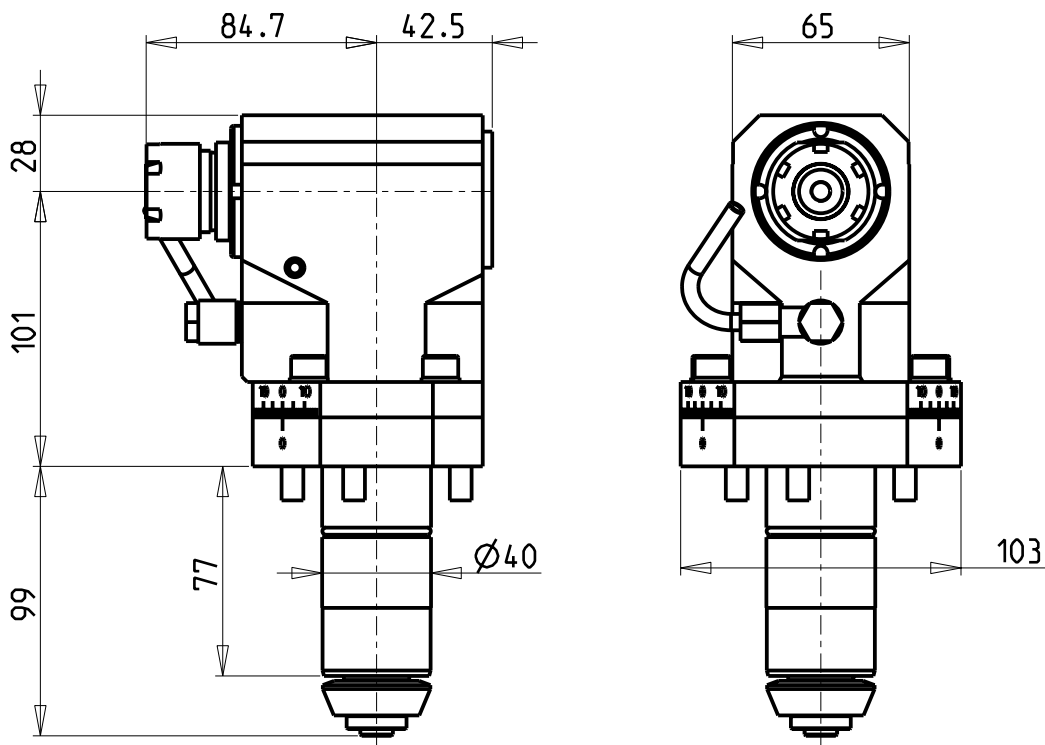

Cod. MT	Mandrino Spindle Spindel	I	RPM	Lubr.esterna Ext. coolant Aussenkuehlung	CHIAVI NON INCLUDE Keys not included Schluessel nicht einbegriffen	
SPC 2091000	ER25	1:1	5000	X	CHMNER25	CHUB36

DMG-MORI
 SPRINT 42/10 LINEAR (8/16ST. TURRET)

MODULO MOTORIZZATO ASSIALE ANGOLARE $\pm 15^\circ$
 Axial adjustable angle $\pm 15^\circ$ driven tool
 Axial angetriebenes Werkzeug schwenkbar $\pm 15^\circ$

Subject to change without notice.

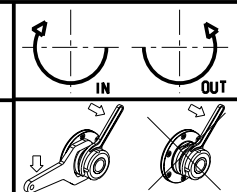

M.T. srl
 Via Casino Albini 480
 Tel. 0541/956034-957884
 Fax 0541/956341
 47842 S. GIOVANNI IN M. (RN)
 e-mail: mtma@mtmarchetti.com
 http://www.mtmarchetti.com

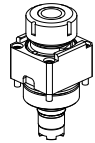
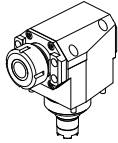

PAGINA SPR355-3-00

		PAGINA Page Seite
MODULO MOTORIZZATO RADIALE Radial driven tool Radial angetriebenes Werkzeug		WAS010.1.00
MODULO MOTORIZZATO ASSIALE H=55mm Axial driven tool H=55mm Axial angetriebenes Werkzeug H=55mm		WAS150.1.10

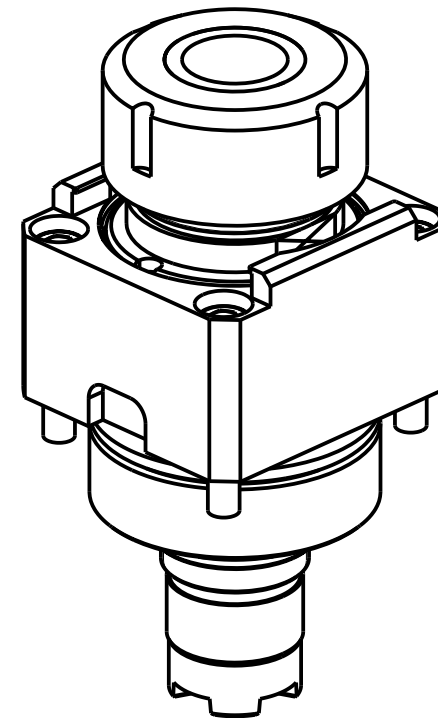
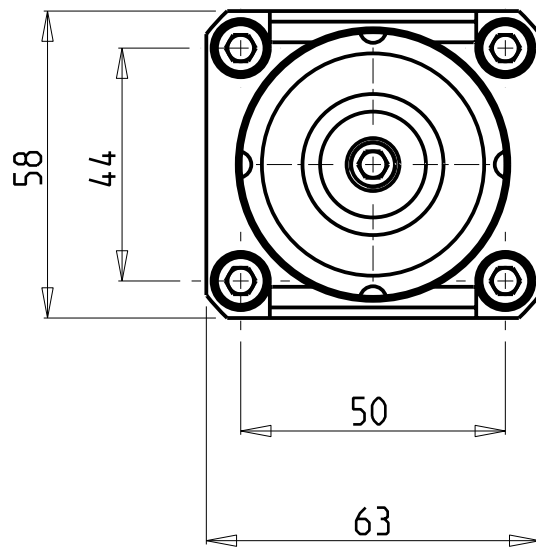
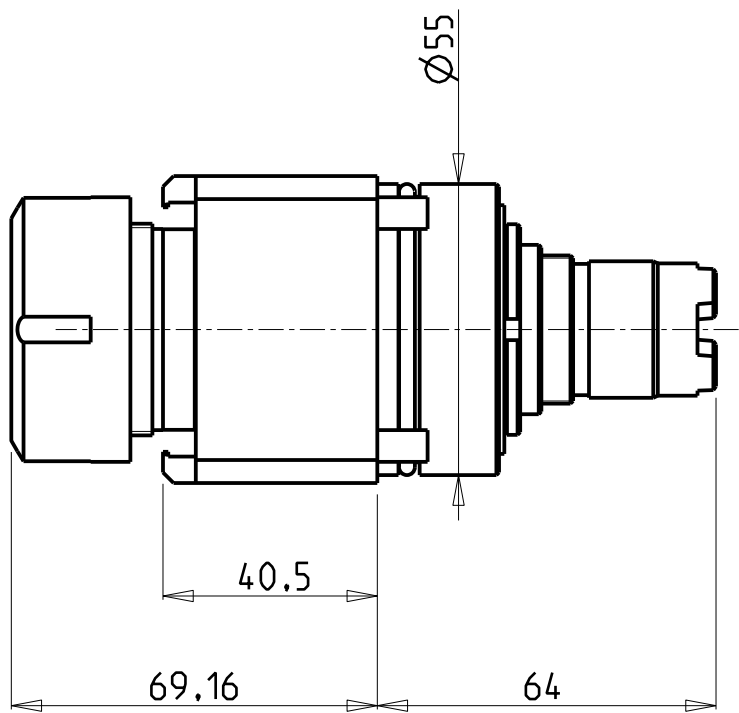

- Chiave inclusa
- Key included
- Schlüssel inbegriffen

Cod. MT	Mandrino Spindle Spindel	I	RPM	Coppia Max Max Torque Max Drehmoment	Lubr.esterna Ext. coolant Aussenkuehlung	CHIAVI NON INCLUSE Keys not included Schlüssel nicht einbegriffen	
WAS0020132	ER32	1:1	10000	35Nm	X	CHSTER32	OKU0290009 ▪

WASINO
MOD: A 150Y/SY

MODULO MOTORIZZATO RADIALE
Radial driven tool
Radial angetriebenes Werkzeug

Subject to change without notice.

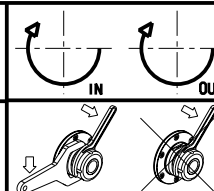

M.T. srl
Via Casino Albini 480
Tel. 0541/956034-957884
Fax 0541/956341
47842 S. GIOVANNI IN M. (RN)
e-mail: mtma@mtmarchetti.com
http://www.mtmarchetti.com



PAGINA WAS010-1-00

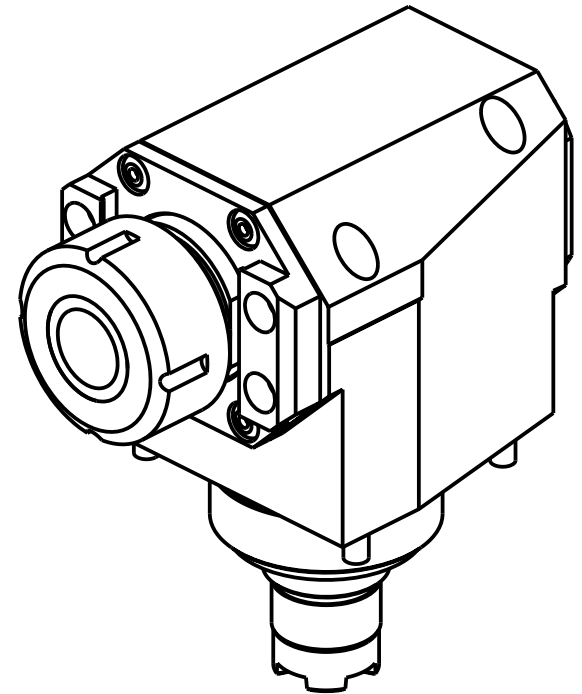
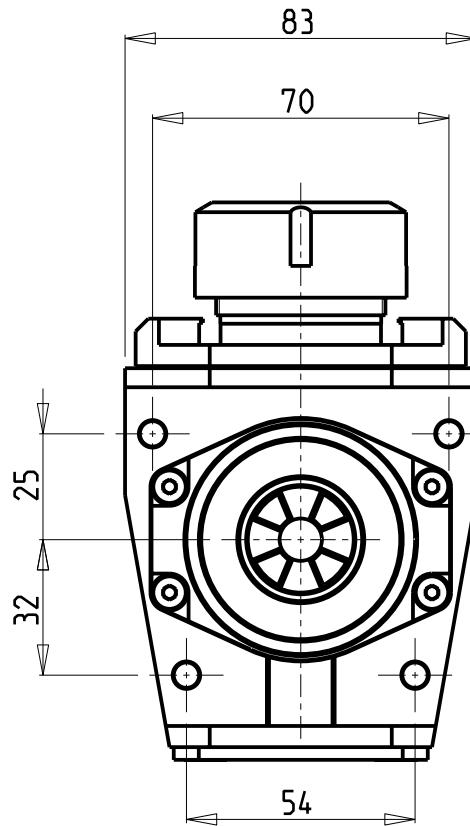
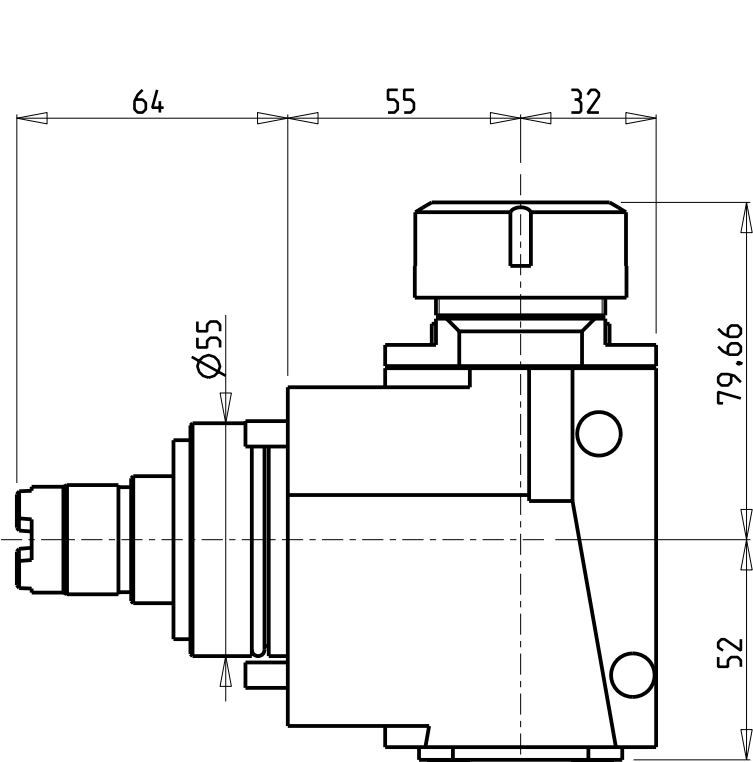

Cod. MT	Mandrino Spindle Spindel	I	RPM	Coppia Max Max Torque Max Drehmoment	Lubr.esterna Ext. coolant Aussenkuehlung	CHIAVI NON INCLUSE Keys not included Schluessel nicht einbegriffen	
WAS0010132	ER32	1:1	10000	35Nm	X	CHSTER32	OKU0290009 ▪

- Chiave inclusa
- Key included
- Schluessel inbegriffen

WASINO

MOD: A 150Y/SY

MODULO MOTORIZZATO ASSIALE H=55mm

Axial driven tool H=55mm

Axial angetriebenes Werkzeug H=55mm

Subject to change without notice.

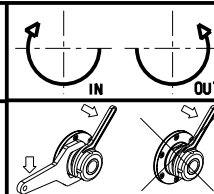

M.T. srl

Via Casino Albini 480
Tel. 0541/956034-957884

Fax 0541/956341

47842 S. GIOVANNI IN M. (RN)

e-mail: mtma@mtmarchetti.com

http://www.mtmarchetti.com



PAGINA WAS150-1-10