

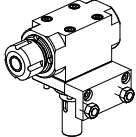
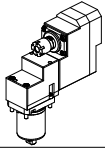
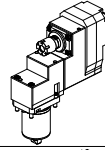
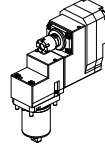
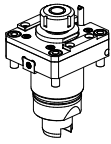
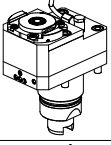
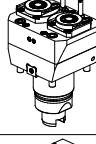
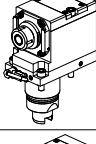
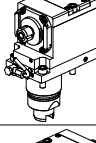
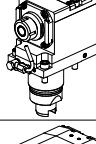
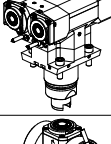
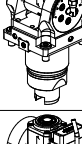
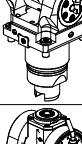
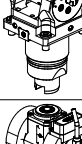
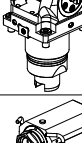

		PAGINA Page Seite
MODULO MOTORIZZATO RADIALE Radial driven tool Radial angetriebenes Werkzeug		TSM010.1.00

		PAGINA Page Seite
<p>MODULO MOTORIZZATO RADIALE Radial driven tool Radial angetriebenes Werkzeug</p>		TSM150.2.10
<p>MODULO MOTORIZZATO RADIALE RIDOTTO I=2:1 Radial geared-down I=2:1 driven tool Radial angetriebenes Werkzeug untersetzt I=2:1</p>		TSM190.2.10
<p>MODULO MOTORIZZATO RADIALE MOLTIPLICATO I=1:2 Radial geared-up I=1:2 driven tool Radial angetriebenes Werkzeug uebersetzt I=1:2</p>		TSM200.2.10

		PAGINA Page Seite
<p>MODULO MOTORIZZATO RADIALE Radial driven tool Radial angetriebenes Werkzeug</p>		TSM010.3.00
<p>MODULO MOTORIZZATO RADIALE MOLTIPLICATO I=1:3 DISASSATO IN Z 47mm Radial geared-up I=1:3 driven tool re-directed in Z by 47mm Radial angetriebenes Werkzeug uebersetzt I=1:3 achsversetzt in Z um 47mm</p>		TSM030.3.50
<p>MODULO MOTORIZZATO RADIALE 2 USCITE IN Y Radial single side twin head driven tool in Y Radial angetriebenes Werkzeug 2 Ausgaenge in Y</p>		TSM080.3.00
<p>MODULO MOTORIZZATO ASSIALE ARRETRATO Axial rear-set driven tool Axial angetriebenes Werkzeug zurueckversetzt</p>		TSM180.3.10
<p>MODULO MOTORIZZATO ASSIALE ARRETRATO MOLTIPLICATO I=1:3 Axial geared-up I=1:3 rear-set driven tool Axial angetriebenes Werkzeug uebersetzt I=1:3 zurueckversetzt</p>		TSM226.3.10
<p>MODULO MOTORIZZATO ASSIALE BISPORGENTE ARRETRATO Axial rear-set opposite face twin driven tool Axial angetriebenes Werkzeug halb vorspringend zurueckversetzt</p>		TSM243.3.10
<p>MODULO MOTORIZZATO ASSIALE 2/4 USCITE IN Y Axial multiple 2/4 outlet driven tool in Y Axial angetriebenes Mehrspindel-Werkzeug 2/4 Ausgaenge in Y</p>		TSM268.3.00
<p>MODULO MOTORIZZATO ORIENTABILE $\pm 90^\circ$ $\pm 90^\circ$ adjustable angle driven tool Angetriebenes Werkzeug schwenkbar $\pm 90^\circ$</p>		TSM335.3.00
<p>MODULO MOTORIZZATO ORIENTABILE $\pm 90^\circ$ CON NONIO DIGITALE $\pm 90^\circ$ adjustable angle driven tool with digital display Angetriebenes Werkzeug schwenkbar $\pm 90^\circ$ mit digital display</p>		TSM335.3.01
<p>MODULO MOTORIZZATO ORIENTABILE $\pm 90^\circ$ MOLTIPLICATO I=1:2 $\pm 90^\circ$ adjustable angle driven tool geared-up I=1:2 Angetriebenes Werkzeug schwenkbar $\pm 90^\circ$ uebersetzt I=1:2</p>		TSM336.3.00
<p>MODULO MOTOR. ORIENTABILE $\pm 90^\circ$ MOLTIPL. I=1:2 CON NONIO DIGITALE $\pm 90^\circ$ adjustable angle driven tool geared-up I=1:2 with digital display Angetriebenes Werkzeug schwenkbar $\pm 90^\circ$ uebersetzt I=1:2 mit digital display</p>		TSM336.3.01
<p>MODULO MOTORIZZATO ASSIALE MTSK PER POWER SKIVING H=80mm Axial MTSK driven tool for Power Skiving H=80mm Axial MTSK angetriebenes Werkzeug fuer Power Skiving H=80mm</p>		TSM350.3.00.K

		PAGINA Page Seite
<p>MODULO MOTORIZZATO STOZZATORE CORSA 50mm H=90mm Slotting driven tool 50mm stroke H=90mm Keilnutenstossmaschine 50mm Hub H=90mm</p>		TSM360.3.00
<p>MODULO MOTORIZZATO STOZZATORE CORSA 25mm H=90mm Slotting driven tool 25mm stroke H=90mm Keilnutenstossmaschine 25mm Hub H=90mm</p>		TSM360.3.01
<p>PORTAUTENSILE RADIALE PER LAMA Radial blade holder Radial Abstechhalter</p>		TSM520.3.01
<p>PORTAUTENSILE RADIALE PER LAMA CON LUBRIFICAZIONE INTERNA Radial blade holder with internal coolant Radial Abstechhalter mit Innenkuehlung</p>		TSM520.3.05
<p>PORTAUTENSILE ASSIALE PER BARENO Ø40mm H=85mm Axial single boring bar holder Ø40mm H=85mm Axial Bohrhalter Ø40mm H=85mm</p>		TSM630.3.10

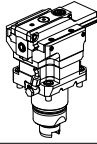
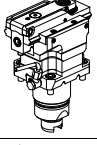
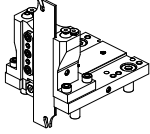
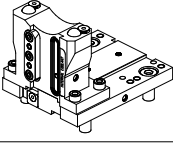
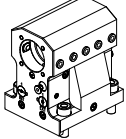
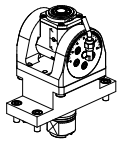
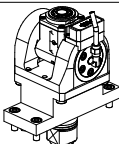
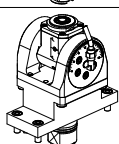
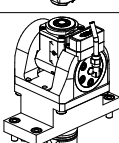
		PAGINA Page Seite
<p>MODULO MOTORIZZATO ORIENTABILE $\pm 90^\circ$ $\pm 90^\circ$ adjustable angle driven tool Angetriebenes Werkzeug schwenkbar $\pm 90^\circ$</p>		TSM335.4.00
<p>MODULO MOTORIZZATO ORIENTABILE $\pm 90^\circ$ CON NONIO DIGITALE $\pm 90^\circ$ adjustable angle driven tool with digital display Angetriebenes Werkzeug schwenkbar $\pm 90^\circ$ mit digital display</p>		TSM335.4.01
<p>MODULO MOTORIZZATO ORIENTABILE $\pm 90^\circ$ MOLTIPLICATO I=1:2 $\pm 90^\circ$ adjustable angle driven tool geared-up I=1:2 Angetriebenes Werkzeug schwenkbar $\pm 90^\circ$ uebersetzt I=1:2</p>		TSM336.4.00
<p>MOD. MOTORIZZ. ORIENTABILE $\pm 90^\circ$ MOLTIPL. I=1:2 CON NONIO DIGITALE $\pm 90^\circ$ adjustable angle driven tool geared-up I=1:2 with digital display Angetriebenes Werkzeug schwenkbar $\pm 90^\circ$ uebersetzt I=1:2 mit digital display</p>		TSM336.4.01

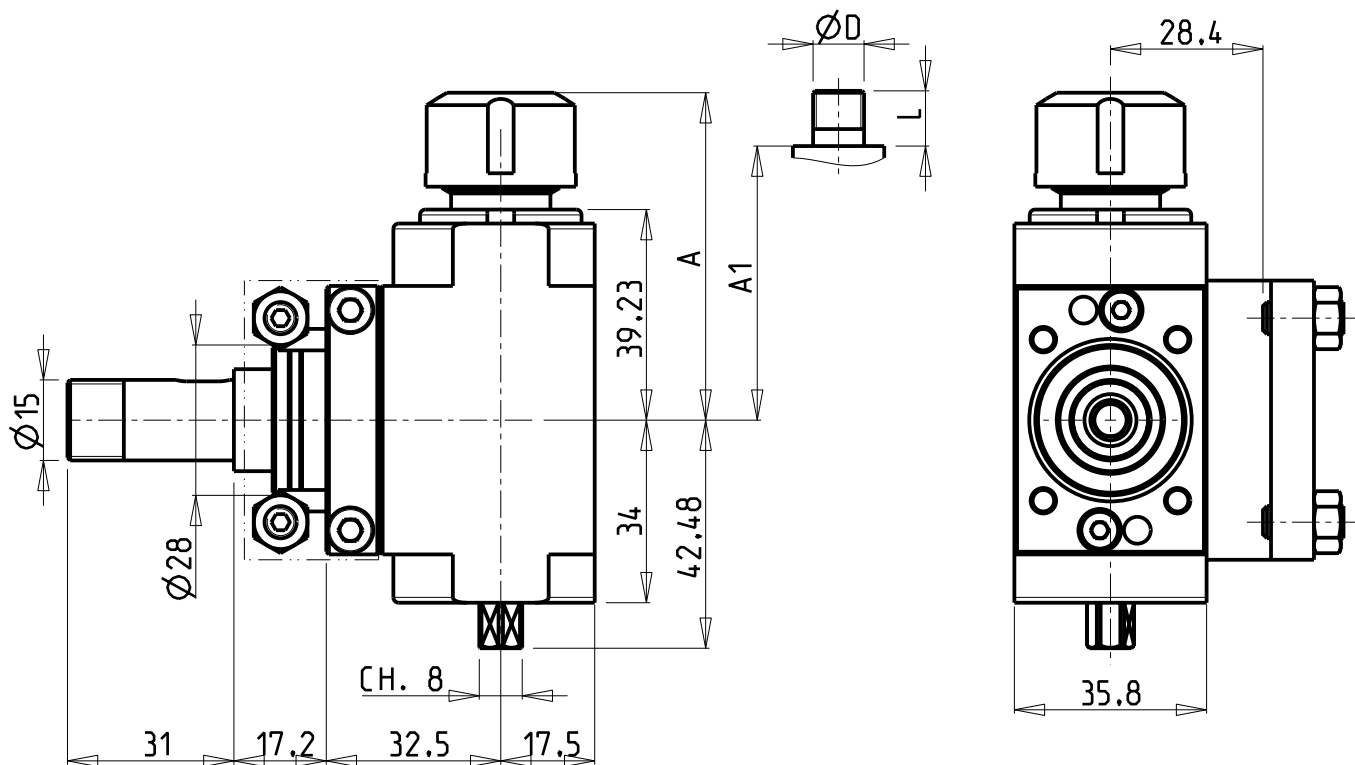

ATTENZIONE - ATTENTION - ACHTUNG

- Per lo smontaggio degli utensili utilizzare sempre la chiave di contrasto come indicato nel manuale d'uso.
- For disassembly of the tools use always the contrast key as mentioned in the user instructions.
- Fuer das Abmontieren der Werkzeuge immer den Gegenschlüssel benutzen wie in der Bedienungsanleitung erwaeht.

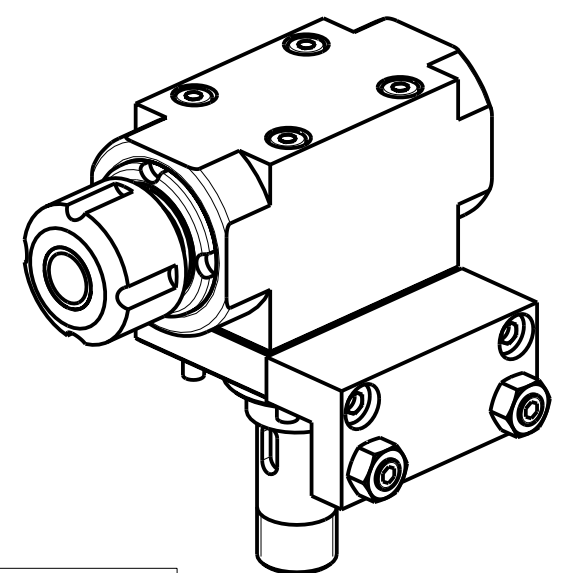

Cod. MT	Mandrino Spindel Spindel	I	RPM	Coppia Max Max Torque Max Drehmoment	Lubrificazione est. Ext. coolant Ausseinkuehlung	A	A1	D	L	Nota Note Note	CHIAVI NON INCLUSE Keys not included Schluessel nicht einbegriffen	
M0090416	ER16	1:1	6000	8Nm	X	60.9	-	-	-	-	CHUB08	CHSTER16
M0090112	$\varnothing 12$	1:1	6000	8Nm	X	-	42	12	13	PORTAFRESA A DISCO MILLING CUTTER HOLDER DISK FLASHALTER	CHUB08	CHUB19
M0090210	$\varnothing 10$	1:1	6000	8Nm	X	-	42	10	13		CHUB08	CHUB17
M0090308	$\varnothing 8$	1:1	6000	8Nm	X	-	42	8	13		CHUB08	CHUB13

TSUGAMI
MOD: BS20/26/32 CIII
MODULO MOTORIZZATO RADIALE
Radial driven tool
Radial angetriebenes Werkzeug

Subject to change without notice.

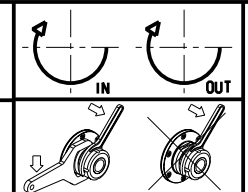

M.T. srl
 Via Casino Albini 480
 Tel. 0541/956034-957884
 Fax 0541/956341
 47842 S. GIOVANNI IN M. (RN)
 e-mail: mtma@mtmarchetti.com
 http://www.mtmarchetti.com



PAGINA TSM010-1-00

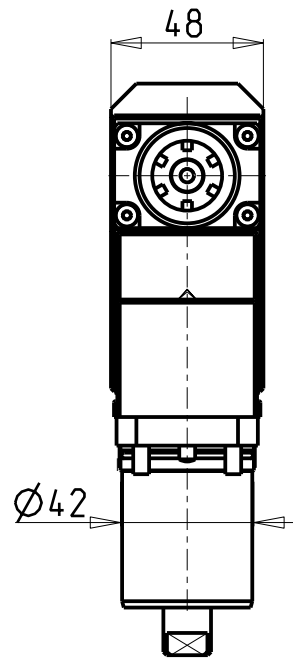
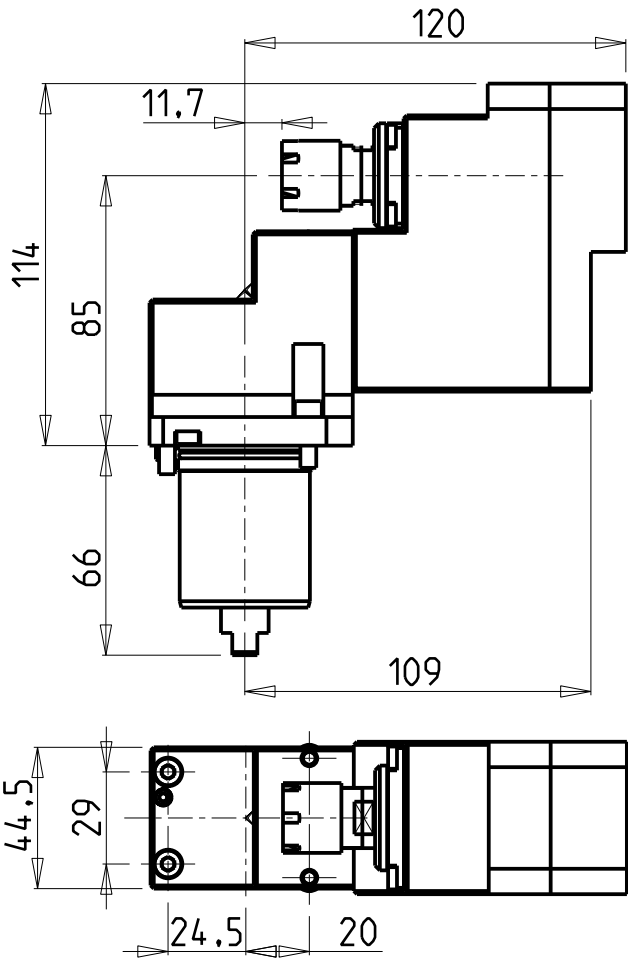

ATTENZIONE - ATTENTION - ACHTUNG

- Per lo smontaggio degli utensili utilizzare sempre la chiave di contrasto come indicato nel manuale d'uso.
- For disassembly of the tools use always the contrast key as mentioned in the user instructions.
- Fuer das Abmontieren der Werkzeuge immer den Gegenschlüssel benutzen wie in der Bedienungsanleitung erwaeht.

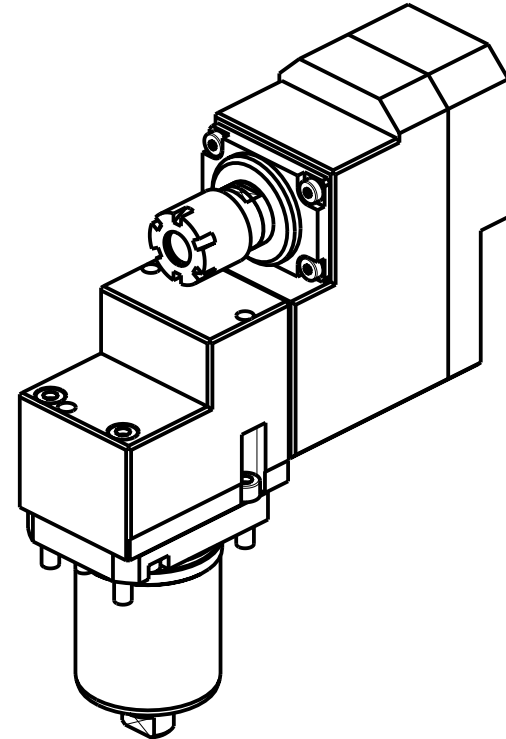

Cod. MT	Mandrino Spindle Spindel	I	RPM	Lubr.esterna Ext. coolant Aussenkuehlung	CHIAVI NON INCLUSE Keys not included Schluessel nicht einbegriffen	
TSM0010116	ER16	1:1	8000	X	CHUB16	CHMNER16

TSUGAMI
 MOD: B0326
 MODULO MOTORIZZATO RADIALE
 Radial driven tool
 Radial angetriebenes Werkzeug
 Subject to change without notice.

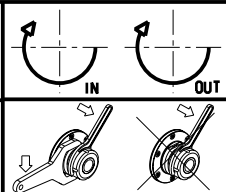

M.T. srl
 Via Casino Albini 480
 Tel. 0541/956034-957884
 Fax 0541/956341
 47842 S. GIOVANNI IN M. (RN)
 e-mail: mtma@mtmarchetti.com
 http://www.mtmarchetti.com



PAGINA TSM150-2-10

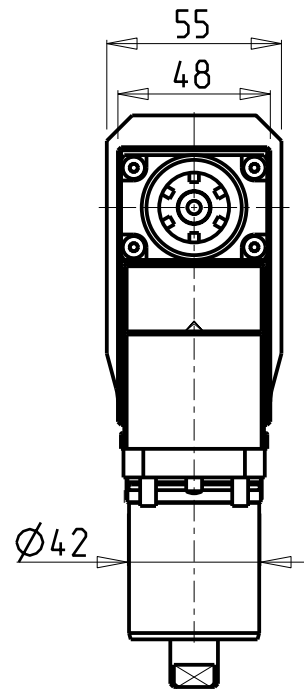
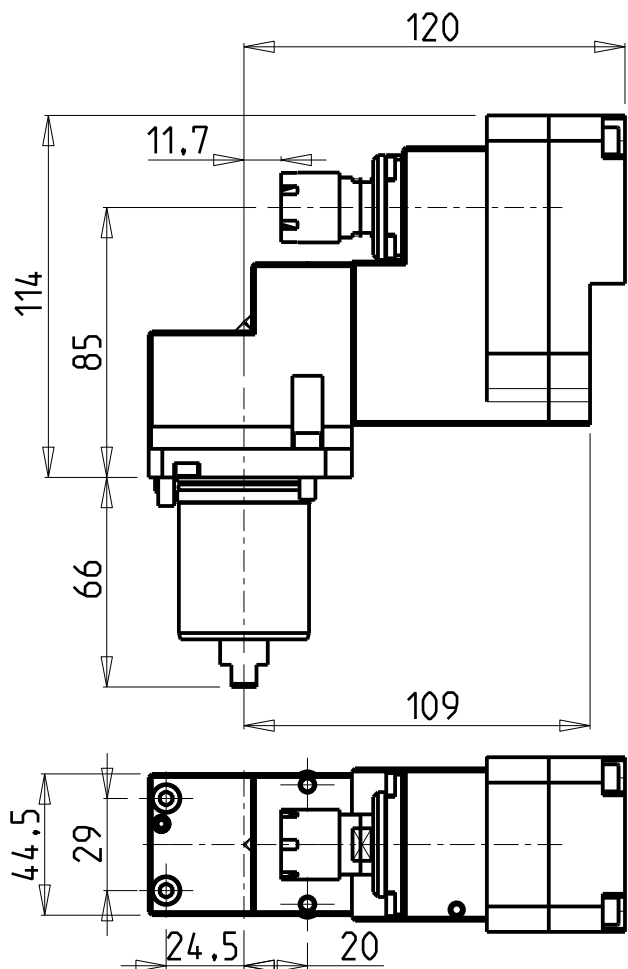

ATTENZIONE - ATTENTION - ACHTUNG

- Per lo smontaggio degli utensili utilizzare sempre la chiave di contrasto come indicato nel manuale d'uso.
- For disassembly of the tools use always the contrast key as mentioned in the user instructions.
- Fuer das Abmontieren der Werkzeuge immer den Gegenschlüssel benutzen wie in der Bedienungsanleitung erwaehtnt.

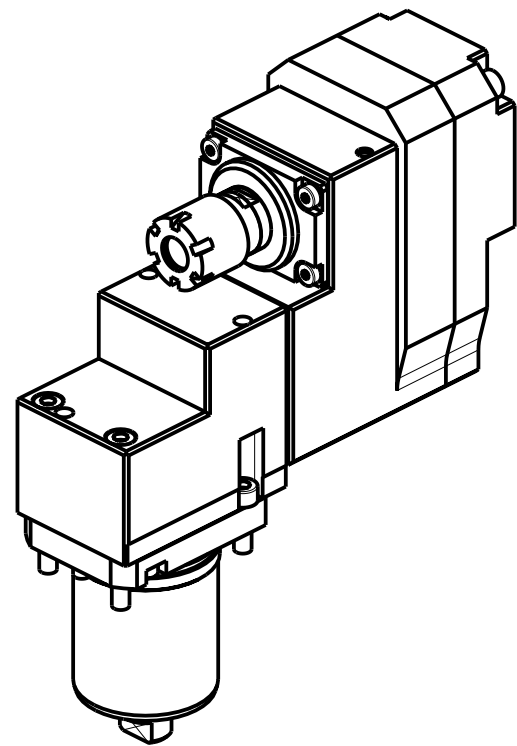

Cod. MT	Mandrino Spindle Spindel	I	RPM	Lubr.esterna Ext. coolant Aussenkuehlung	CHIAVI NON INCLUDE Keys not included Schluessel nicht einbegriffen	
TSM0020116	ER16	2:1	4000	X	CHUB16	CHMNER16

TSUGAMI
MOD: B0326

MODULO MOTORIZZATO RADIALE RIDOTTO I=2:1
Radial geared-down I=2:1 driven tool
Radial angetriebenes Werkzeug untersetzt I=2:1

Subject to change without notice.

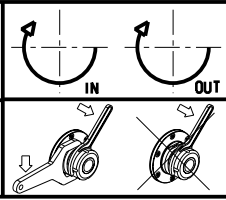

M.T. srl
Via Casino Albini 480
Tel. 0541/956034-957884
Fax 0541/956341
47842 S. GIOVANNI IN M. (RN)
e-mail: mtma@mtmarchetti.com
http://www.mtmarchetti.com



PAGINA TSM190-2-10

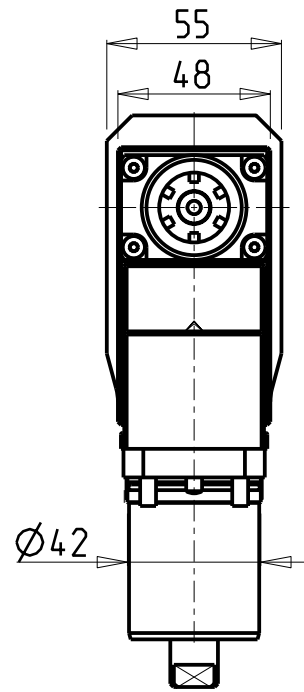
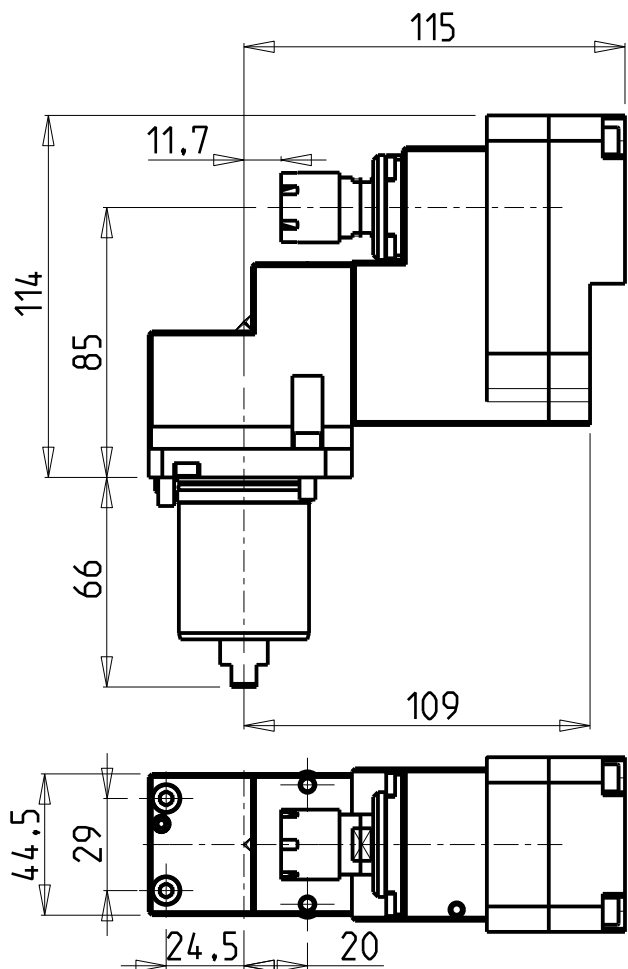

ATTENZIONE - ATTENTION - ACHTUNG

- Per lo smontaggio degli utensili utilizzare sempre la chiave di contrasto come indicato nel manuale d'uso.
- For disassembly of the tools use always the contrast key as mentioned in the user instructions.
- Fuer das Abmontieren der Werkzeuge immer den Gegenschlüssel benutzen wie in der Bedienungsanleitung erwaehtnt.

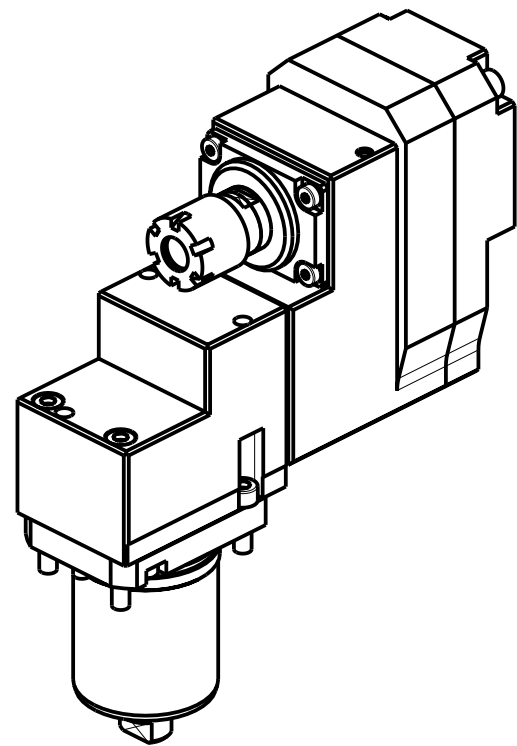

Cod. MT	Mandrino Spindle Spindel	I	RPM	Lubr.esterna Ext. coolant Aussenkuehlung	CHIAVI NON INCLUDE Keys not included Schluessel nicht einbegriffen	
TSM0030116	ER16	1:2	16000	X	CHUB16	CHMNER16

TSUGAMI
MOD: B0326

MODULO MOTORIZZATO RADIALE MOLTIPLICATO I=1:2
Radial geared-up I=1:2 driven tool
Radial angetriebenes Werkzeug uebersetzt I=1:2

Subject to change without notice.

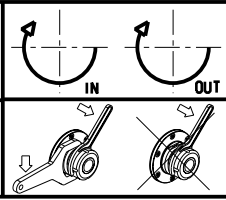

M.T. srl
Via Casino Albini 480
Tel. 0541/956034-957884
Fax 0541/956341
47842 S. GIOVANNI IN M. (RN)
e-mail: mtma@mtmarchetti.com
http://www.mtmarchetti.com



PAGINA TSM200-2-10

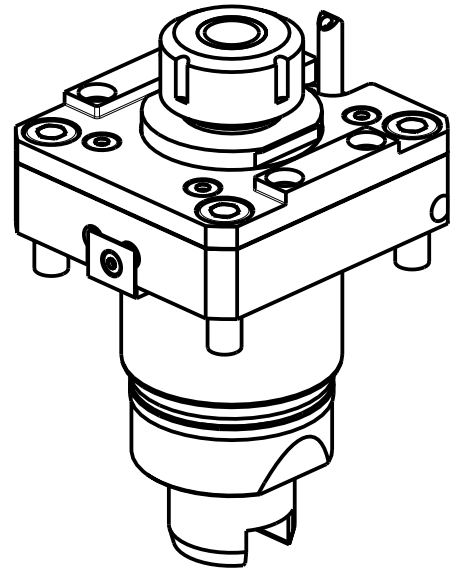
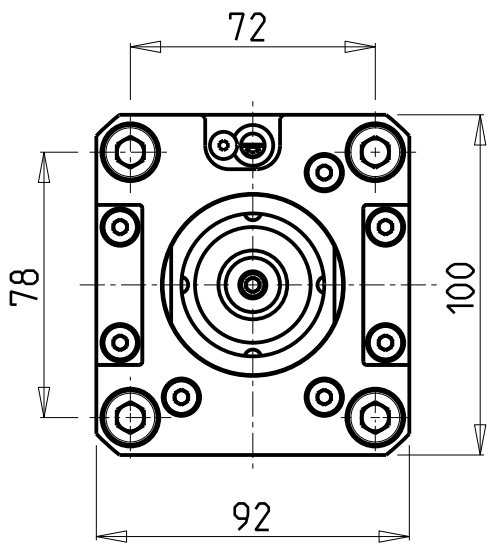
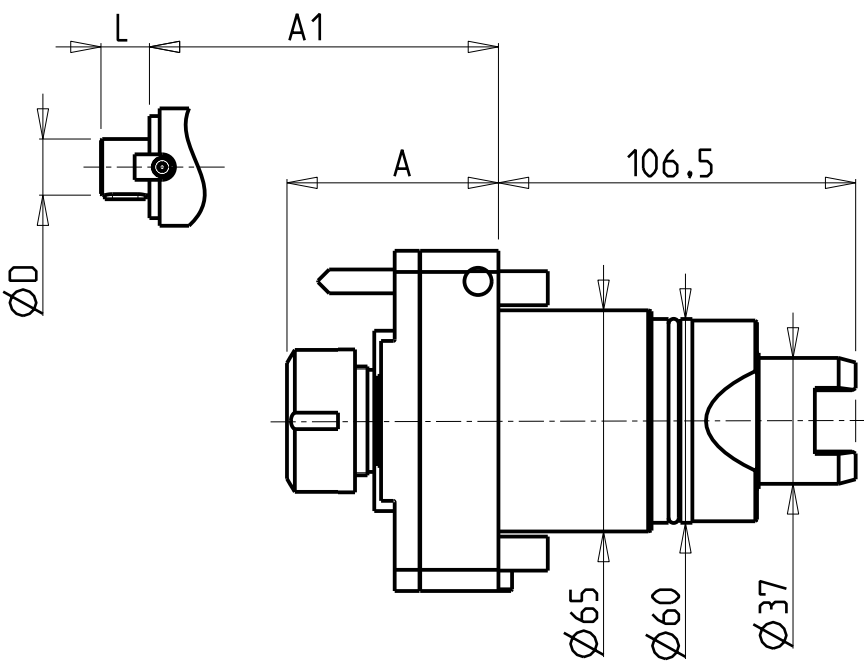

- Chiave inclusa
- Key included
- Schlüssel inbegriffen

Cod. MT	Mandrino Spindle Spindel	I	RPM	Coppia Max Max Torque Max Drehmoment	Lubr.interna Coolant through Innenkuehlung	Lubrificazione est. Ext. coolant Aussenkuehlung	A	A1	D	L	CHIAVI NON INCLUSE Keys not included Schlüssel nicht einbegriffen	
TSM0060125	ER25	1:1	5000	50Nm	-	X	62.2	-	-	-	CHSTER25	OKU0650004
TSM0065225	ER25	1:1	5000	50Nm	P=70bar	X	84.2	-	-	-	CHSTER25	OKU0650004
TSM0060516	Ø16x17	1:1	5000	50Nm	-	X	-	39.5	16	17	CH_VTCROCE_M08	OKU0650004
TSM0060522	Ø22x19	1:1	5000	50Nm	-	X	-	41	22	19	CH_VTCROCE_M10	OKU0650004

NEW

TSUGAMI
MOD: M06 - M08
MODULO MOTORIZZATO RADIALE
Radial driven tool
Radial angetriebenes Werkzeug

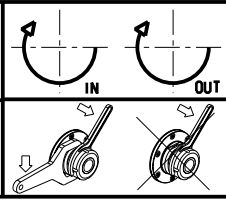

M.T. srl
 Via Casino Albini 480
 Tel. 0541/956034-957884
 Fax 0541/956341
 47842 S. GIOVANNI IN M. (RN)
 e-mail: mtma@mtmarchetti.com
 http://www.mtmarchetti.com



PAGINA TSM010-3-00

Subject to change without notice.

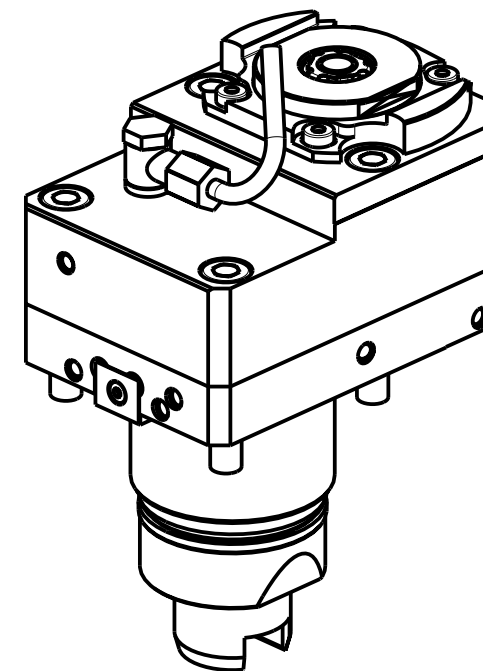
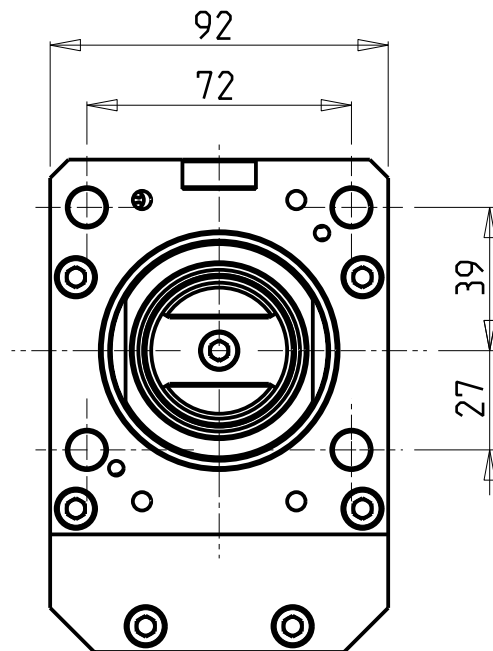
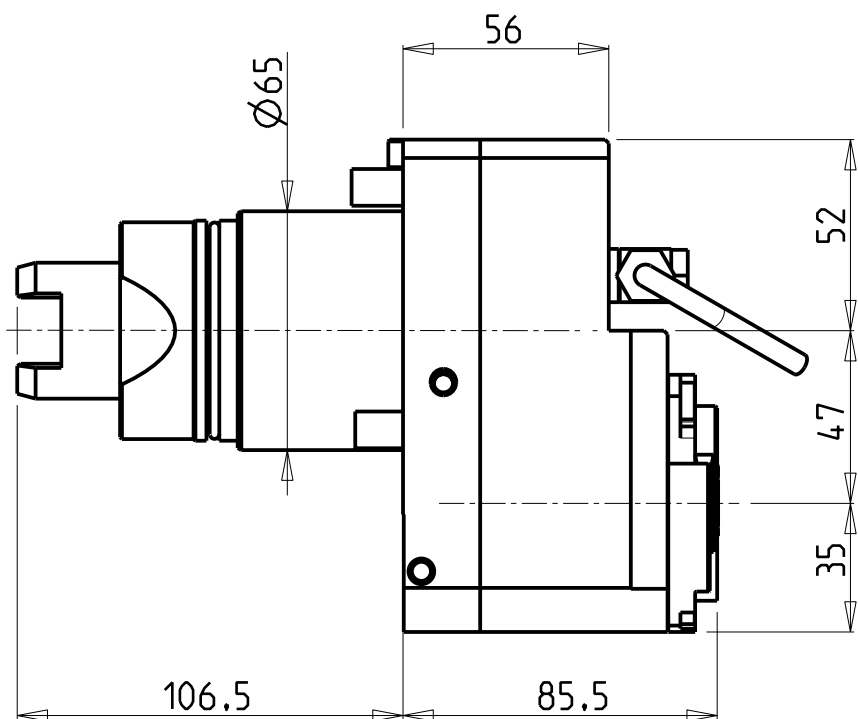

- Chiave inclusa
- Key included
- Schlüssel inbegriffen

Cod. MT	Mandrino Spindle Spindel	I	RPM	Coppia Max Max Torque Max Drehmoment	Reversibile lato mandrino/contromandrino Reversible sub/main spindle side Umkehrbare Spindel-seite/ Gegenspindel-seite	Lubrificazione int. Coolant through Innenkuehlung	Lubrificazione est. Ext. coolant Aussenkuehlung	CHIAVI NON INCLUSE Keys not included Schlüssel nicht einbegriffen		
								CHUB19_SP3	OKU0650004	CHTAER16ZC
TSM0170316	ERA16	1:3	15000	15Nm	X	-	X	CHUB19_SP3	OKU0650004	CHTAER16ZC
TSM0170416	ERA16	1:3	15000	15Nm	X	P=70bar	X	CHUB19_SP3	OKU0650004	CHTAER16ZC

TSUGAMI
MOD: M06 - M08

MODULO MOTORIZZATO RADIALE MOLTIPLICATO I=1:3 DISASSATO IN Z 47mm
Radial geared-up I=1:3 driven tool re-directed in Z by 47mm
Radial angetriebenes Werkzeug uebersetzt I=1:3 achsversetzt in Z um 47mm

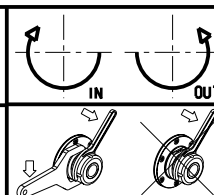

M.T. srl
Via Casino Albini 480
Tel. 0541/956034-957884
Fax 0541/956341
47842 S. GIOVANNI IN M. (RN)
e-mail: mtma@mtmarchetti.com
http://www.mtmarchetti.com



PAGINA TSM030-3-50

Subject to change without notice.

10/2021

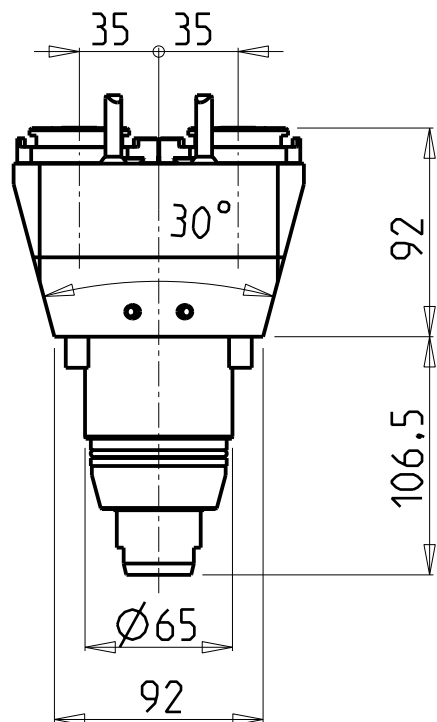
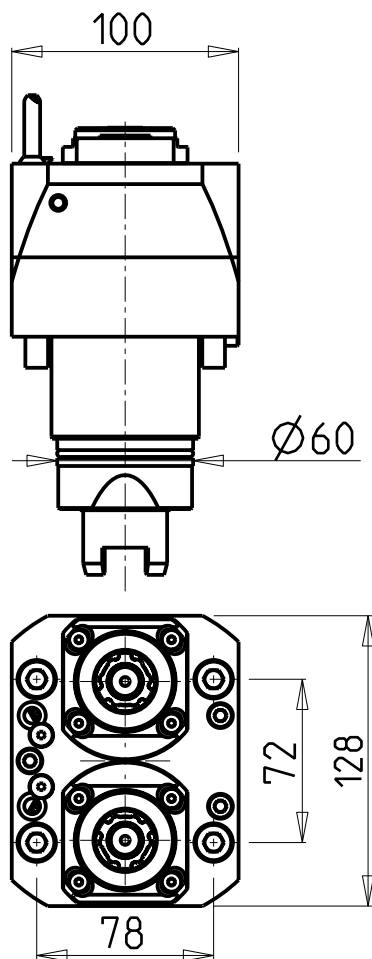

ATTENZIONE - ATTENTION - ACHTUNG

- Per lo smontaggio degli utensili utilizzare sempre la chiave di contrasto come indicato nel manuale d'uso.
- For disassembly of the tools use always the contrast key as mentioned in the user instructions.
- Fuer das Abmontieren der Werkzeuge immer den Gegenschlüssel benutzen wie in der Bedienungsanleitung erwaehnt.

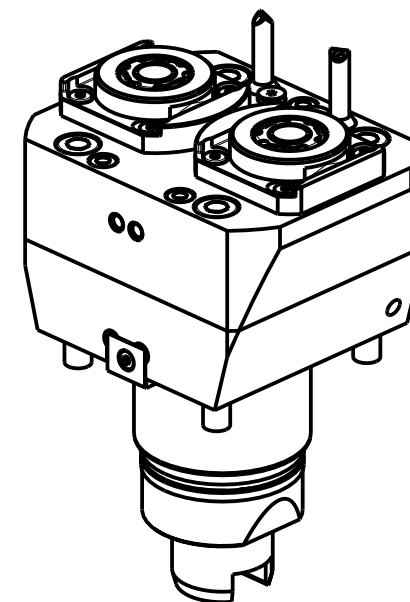

- Chiave inclusa
- Key included
- Schlüssel inbegriffen

Cod. MT	Mandrino Spindle Spindel	I	RPM	Coppia Max Max Torque Max Drehmoment	Lubrificazione int. Coolant through Innenkuehlung	Lubrificazione est. Ext. coolant Aussenkuehlung	CHIAVI NON INCLUSE Keys not included Schlüssel nicht einbegriffen		
TSM0110120	ERA20	1:1	5000	50Nm	-	X	CHUB22	CHTAER20ZC	OKU0290009
TSM0110220	ERA20	1:1	5000	50Nm	P=70bar	X	CHUB22	CHTAER20ZC	OKU0290009

TSUGAMI
MOD: M06 - M08

MODULO MOTORIZZATO RADIALE 2 USCITE IN Y
Radial single side twin head driven tool in Y
Radial angetriebenes Werkzeug 2 Ausgaenge in Y

Subject to change without notice.

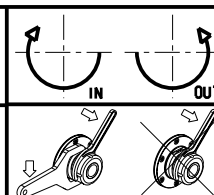

M.T. srl

Via Casino Albini 480
Tel. 0541/956034-957884
Fax 0541/956341
47842 S. GIOVANNI IN M. (RN)
e-mail: mtma@mtmarchetti.com
http://www.mtmarchetti.com



PAGINA TSM080-3-00

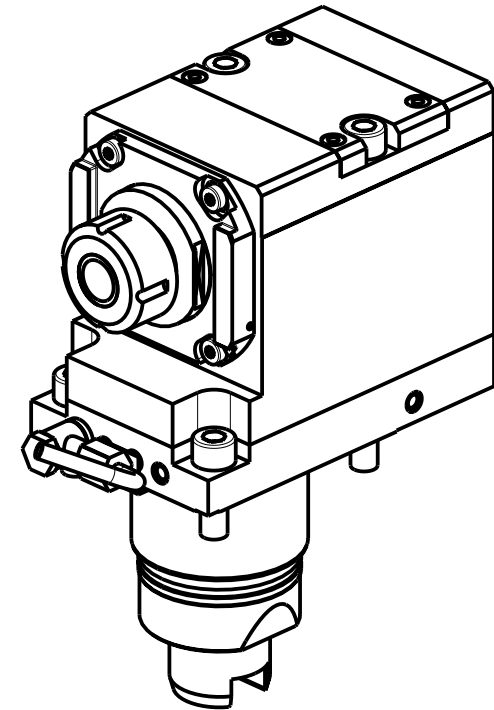
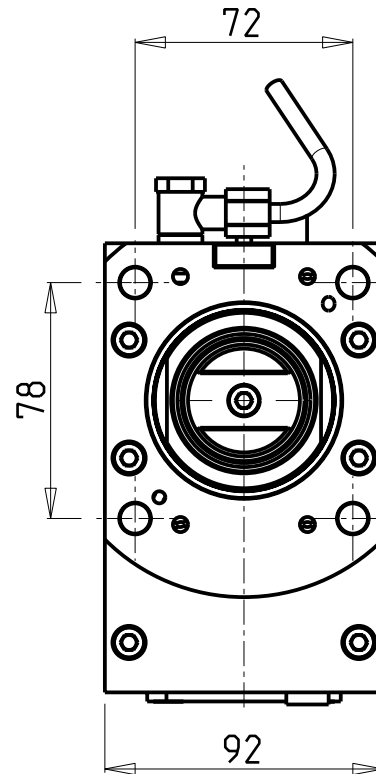
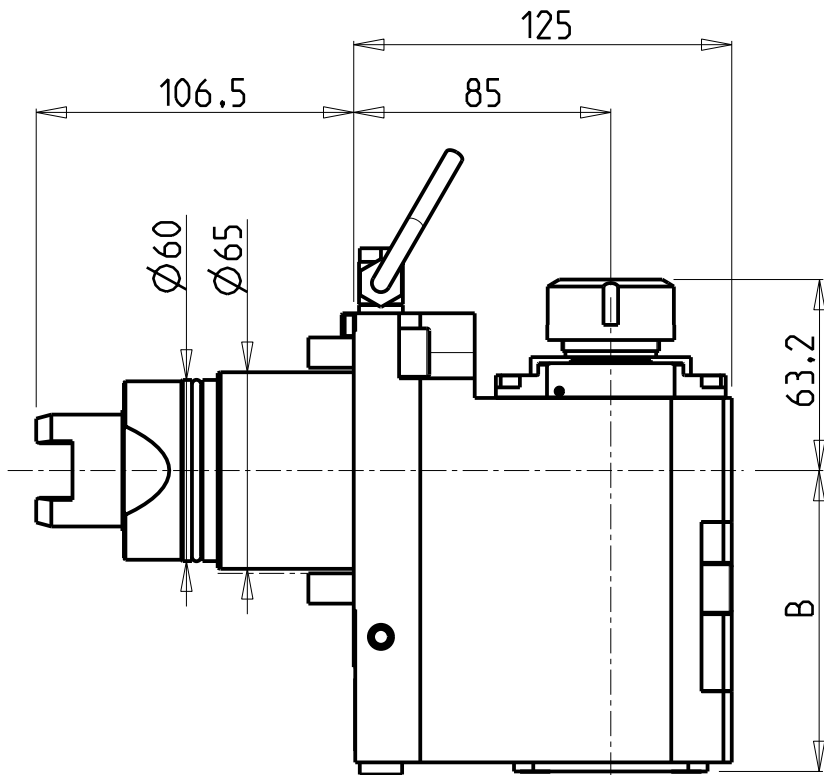

Cod. MT	Mandrino Spindle Spindel	I	RPM	Coppia Max Max Torque Max Drehmoment	Reversibile lato mandrino/contromandrino Reversible sub/main spindle side Umkehrbare Spindel-seite/ Gegenspindel-seite	Lubr.interna Coolant through Innenkuehlung	Lubr.esterna Ext. coolant Aussenkuehlung	B	CHIAVI NON INCLUSE Keys not included Schlüssel nicht einbegriffen	
TSM0070125	ER25	1:1	5000	50Nm	X	-	X	99.5	CHSTER25	OKU0650004 *
TSM0070225	ER25	1:1	5000	50Nm	X	P=70bar	X	112	CHSTER25	OKU0650004 *

- Chiave inclusa
- Key included
- Schlüssel einbegriffen

TSUGAMI
MOD: M06 - M08

MODULO MOTORIZZATO ASSIALE ARRETRATO
Axial rear-set driven tool
Axial angetriebenes Werkzeug zurueckversetzt

Subject to change without notice.

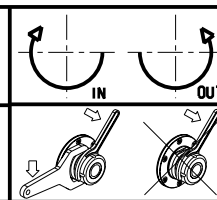

M.T. srl
Via Casino Albini 480
Tel. 0541/956034-957884
Fax 0541/956341
47842 S. GIOVANNI IN M. (RN)
e-mail: mtma@mtmarchetti.com
http://www.mtmarchetti.com



PAGINA TSM180-3-10

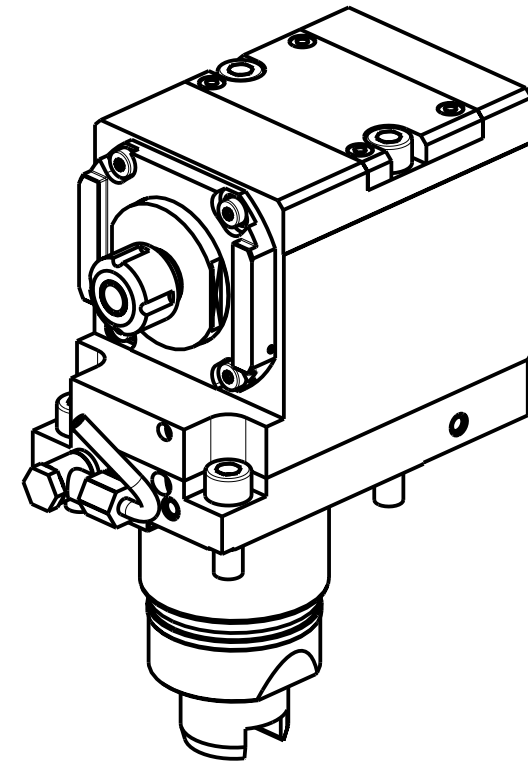
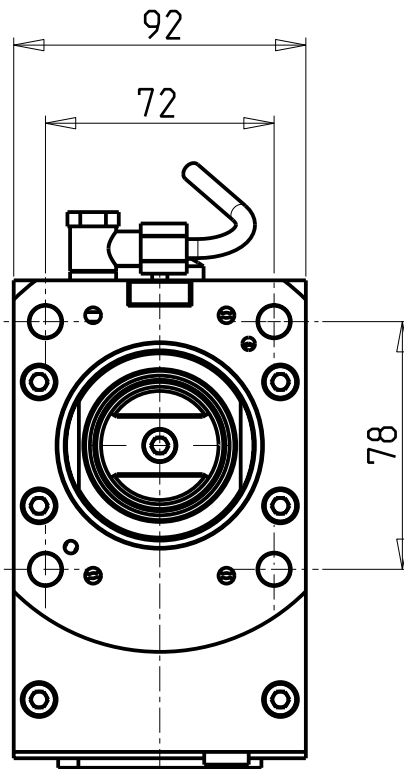
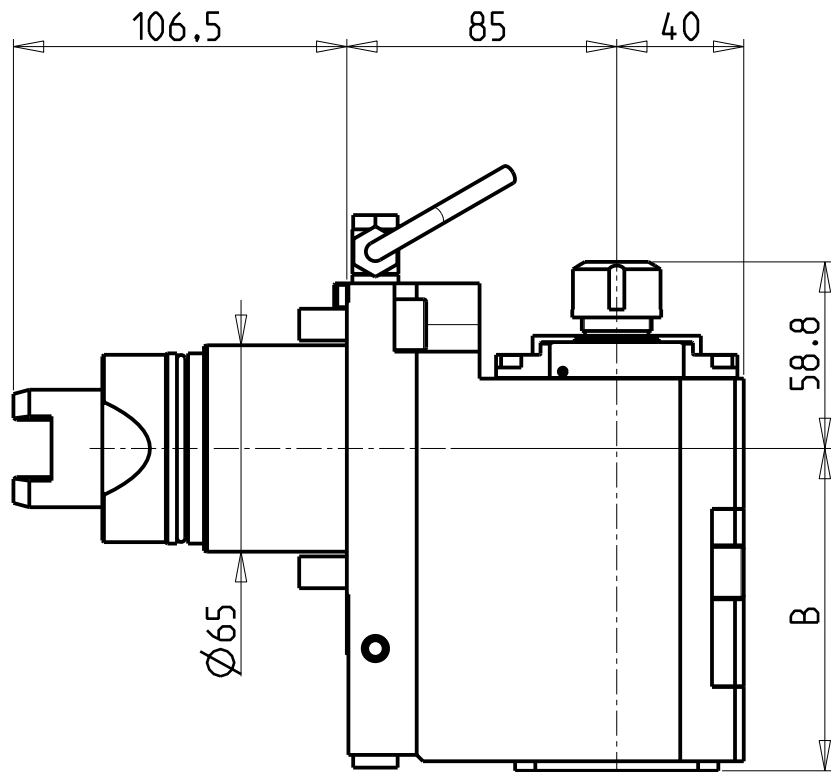

- Chiave inclusa
- Key included
- Schluessel inbegriffen

Cod. MT	Mandrino Spindle Spindel	I	RPM	Coppia Max Max Torque Max Drehmoment	Reversibile lato mandrino/contromandrino Reversible sub/main spindle side Umkehrbare Spindel-seite/ Gegenspindel-seite	Lubrificazione int. Coolant through Innenkuehlung	Lubrificazione est. Ext. coolant Aussenkuehlung	B	CHIAVI NON INCLUSE Keys not included Schluessel nicht inbegriffen	
									CHSTER16	OKU0650004
TSM0180116	ER16	1:3	15000	15Nm	X	-	X	101.5	CHSTER16	OKU0650004
TSM0180216	ER16	1:3	15000	15Nm	X	P=70bar	X	114	CHSTER16	OKU0650004

TSUGAMI
MOD: M06 - M08

MODULO MOTORIZZATO ASSIALE ARRETRATO MOLTIPLICATO I=1:3
Axial geared-up I=1:3 rear-set driven tool
Axial angetriebenes Werkzeug uebersetzt I=1:3 zurueckversetzt

Subject to change without notice.

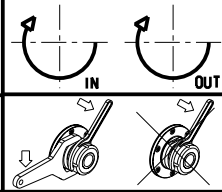

M.T. srl
Via Casino Albini 480
Tel. 0541/956034-957884
Fax 0541/956341
47842 S. GIOVANNI IN M. (RN)
e-mail: mtma@mtmarchetti.com
http://www.mtmarchetti.com



PAGINA TSM226-3-10

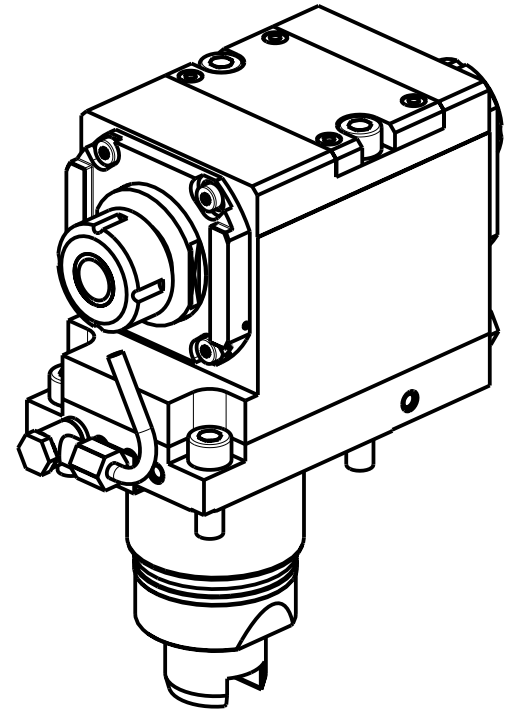
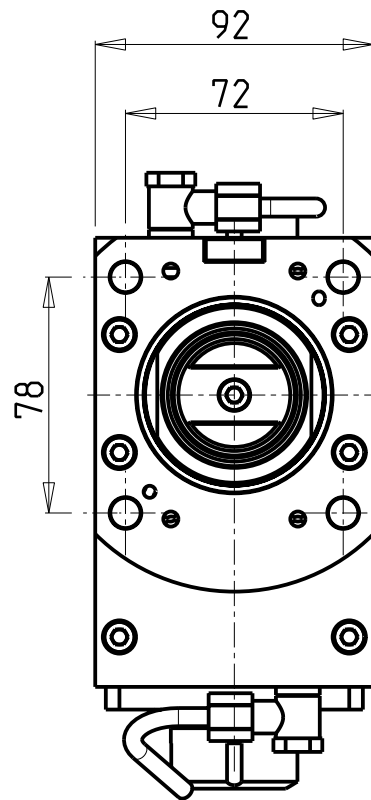
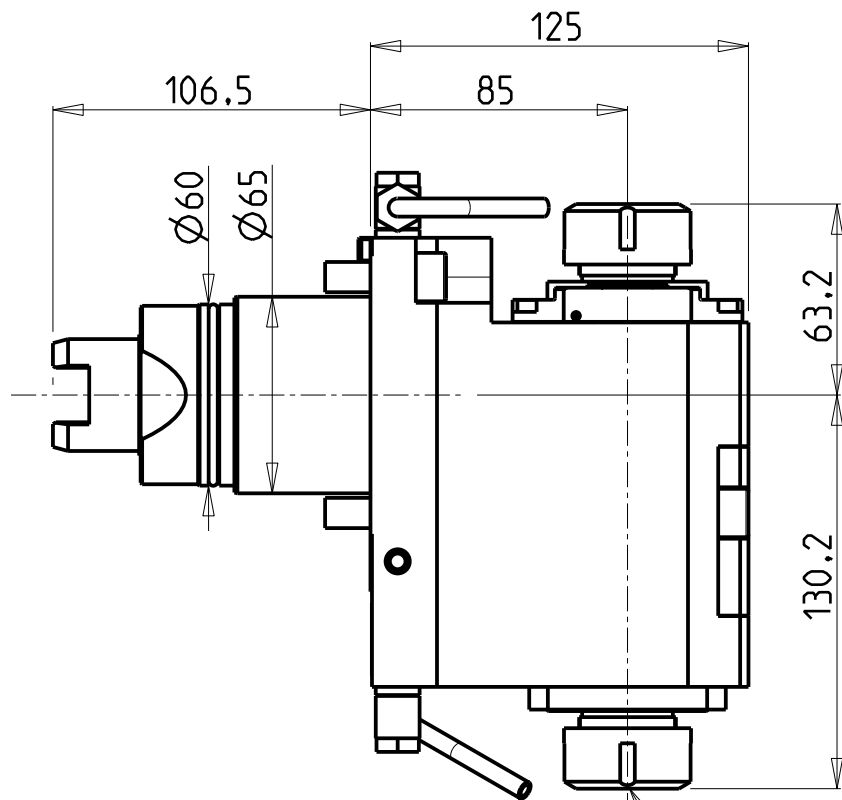

-Attenzione: Montare obbligatoriamente questo lato verso il mandrino principale.
 -Attention: This side must be mounted towards main spindle.
 -Achtung: Diese Seite muss in Richtung Hauptspindel montiert.

Cod. MT	Mandrino Spindle Spindel	I	RPM	Coppia Max Max Torque Max Drehmoment	Lubr.esterna Ext. coolant Aussenkuehlung	CHIAVI NON INCLUSE Keys not included Schluessel nicht einbegriffen	
TSM0080225	ER25-ER25	1:1	5000	50Nm	X	CHSTER25	OKU0650004 ■

- Chiave inclusa
- Key included
- Schluessel inbegriffen

TSUGAMI
 MOD: M06 - M08

MODULO MOTORIZZATO ASSIALE BISPORGENTE ARRETRATO
 Axial rear-set opposite face twin driven tool
 Axial angetriebenes Werkzeug halb vorspringend zurueckversetzt

Subject to change without notice.

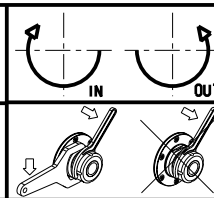

M.T. srl
 Via Casino Albini 480
 Tel. 0541/956034-957884
 Fax 0541/956341
 47842 S. GIOVANNI IN M. (RN)
 e-mail: mtma@mtmarchetti.com
 http://www.mtmarchetti.com



PAGINA TSM243-3-10

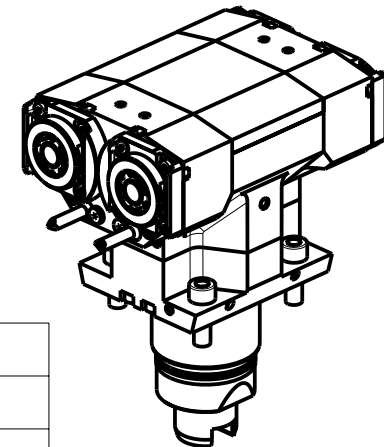
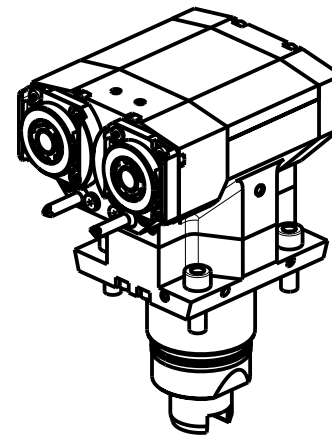
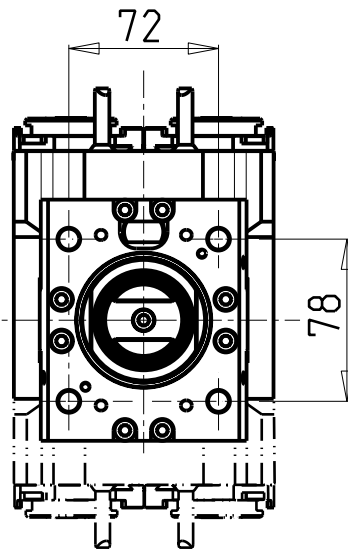
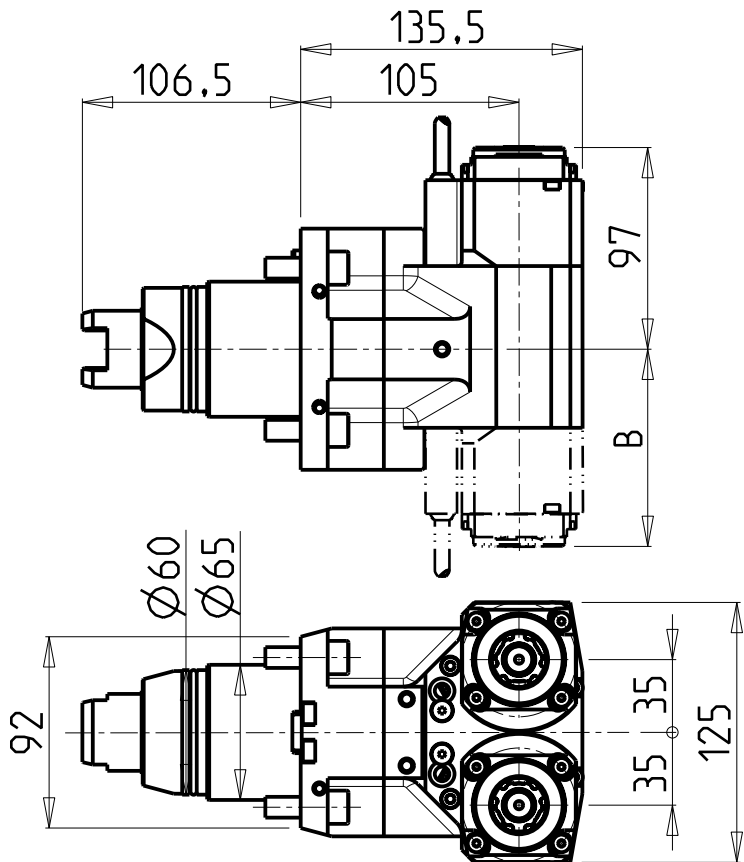

ATTENZIONE - ATTENTION - ACHTUNG

- Per lo smontaggio degli utensili utilizzare sempre la chiave di contrasto come indicato nel manuale d'uso.
- For disassembly of the tools use always the contrast key as mentioned in the user instructions.
- Fuer das Abmontieren der Werkzeuge immer den Gegenschlüssel benutzen wie in der Bedienungsanleitung erwaeht.

- Chiave inclusa
- Key included
- Schluessel inbegriffen

Cod. MT	Mandrino Spindle Spindel	I	RPM	Coppia Max Max Torque Max Drehmoment	N°Utensili N°Tools N°Werkzeuge	Reversibile lato mandrino/contromandrino Reversible sub/main spindle side Umkehrbare Spindel-seite/ Gegenspindel-seite	Lubrificazione int. Coolant through Innenkuehlung	Lubr.esterna Ext. coolant Aussenkuehlung	B	CHIAVI NON INCLUSE Keys not included Schluessel nicht einbegriffen		
TSM0150120	ERA20	1:1	5000	50Nm	2	X	-	X	56.8	CHUB22	CHTAER20ZC	OKU0290009
TSM0151120	ERA20+ERA20	1:1	5000	50Nm	2+2	X	-	X	94.8	CHUB22	CHTAER20ZC	OKU0290009
TSM0150220	ERA20	1:1	5000	50Nm	2	X	P=70bar	X	56.8	CHUB22	CHTAER20ZC	OKU0290009
TSM0151220	ERA20+ERA20	1:1	5000	50Nm	2+2	X	P=70bar	X	94.8	CHUB22	CHTAER20ZC	OKU0290009

TSUGAMI
MOD: M06 - M08

MODULO MOTORIZZATO ASSIALE 2/4 USCITE IN Y
Axial multiple 2/4 outlet driven tool in Y
Axial angetriebenes Mehrspindel-Werkzeug 2/4 Ausgaenge in Y

Subject to change without notice.

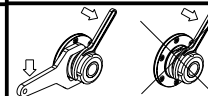

M.T. srl
Via Casino Albini 480
Tel. 0541/956034-957884
Fax 0541/956341
47842 S. GIOVANNI IN M. (RN)
e-mail: mtma@mtmarchetti.com
http://www.mtmarchetti.com



PAGINA TSM268-3-00

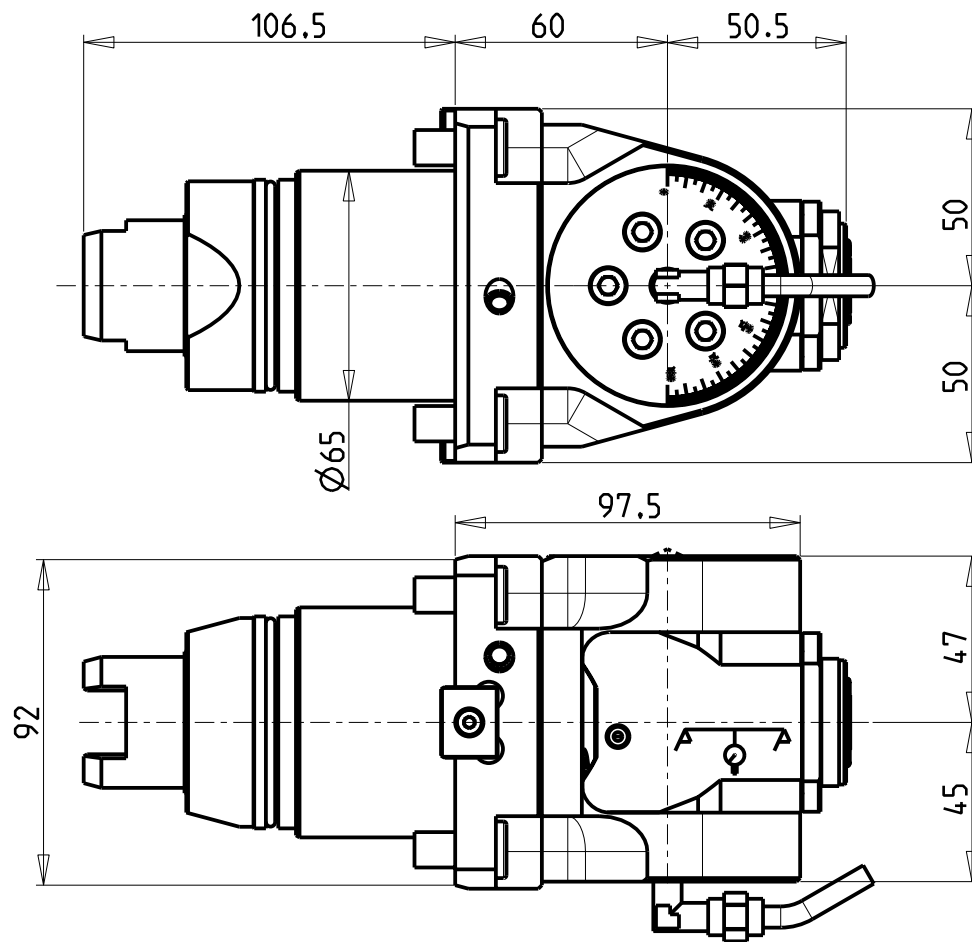
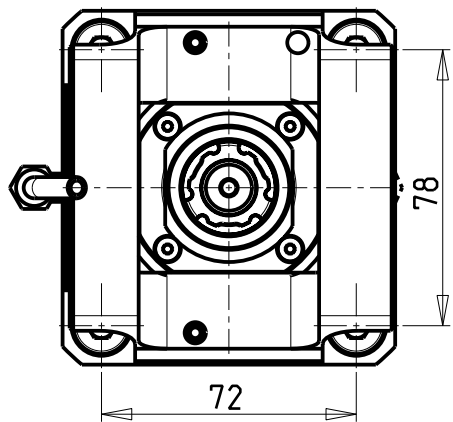

ATTENZIONE - ATTENTION - ACHTUNG

- Per lo smontaggio degli utensili utilizzare sempre la chiave di contrasto come indicato nel manuale d'uso.
- For disassembly of the tools use always the contrast key as mentioned in the user instructions.
- Fuer das Abmontieren der Werkzeuge immer den Gegenschlüssel benutzen wie in der Bedienungsanleitung erwäohnt.

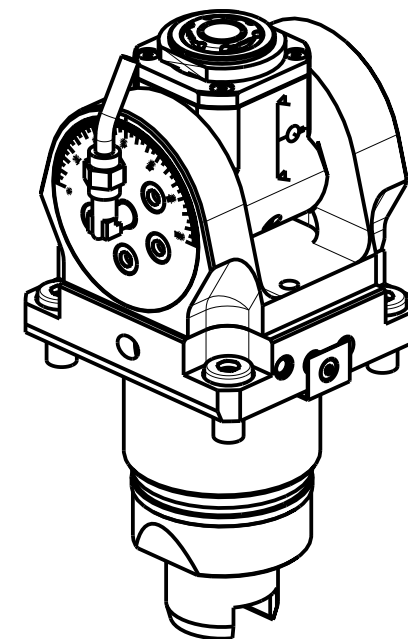

Cod. MT	Mandrino Spindle Spindel	I	RPM	Coppia Max Max Torque Max Drehmoment	Lubrificazione int. Coolant through Innenkuehlung	Lubrificazione est. Ext. coolant Aussenkuehlung	CHIAVI INCLUSE Keys included Schluesssel inbegriffen			
							CHUB22	CHUB36	CHTAER20ZC	CHESL07
TSM0100120	ERA20	1:1	5000	30Nm	-	X	CHUB22	CHUB36	CHTAER20ZC	CHESL07
TSM0100220	ERA20	1:1	5000	30Nm	P=70bar	X	CHUB22	CHUB36	CHTAER20ZC	CHESL07

TSUGAMI

MOD: M06 - M08

MODULO MOTORIZZATO ORIENTABILE +/-90°
 +/-90° adjustable angle driven tool
 Angetriebenes Werkzeug schwenkbar +/-90°

Subject to change without notice.

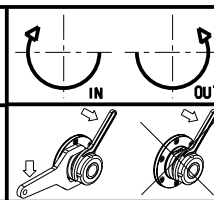

M.T. srl

Via Casino Albini 480
 Tel. 0541/956034-957884
 Fax 0541/956341
 47842 S. GIOVANNI IN M. (RN)
 e-mail: mtma@mtmarchetti.com
 http://www.mtmarchetti.com



PAGINA TSM335-3-00

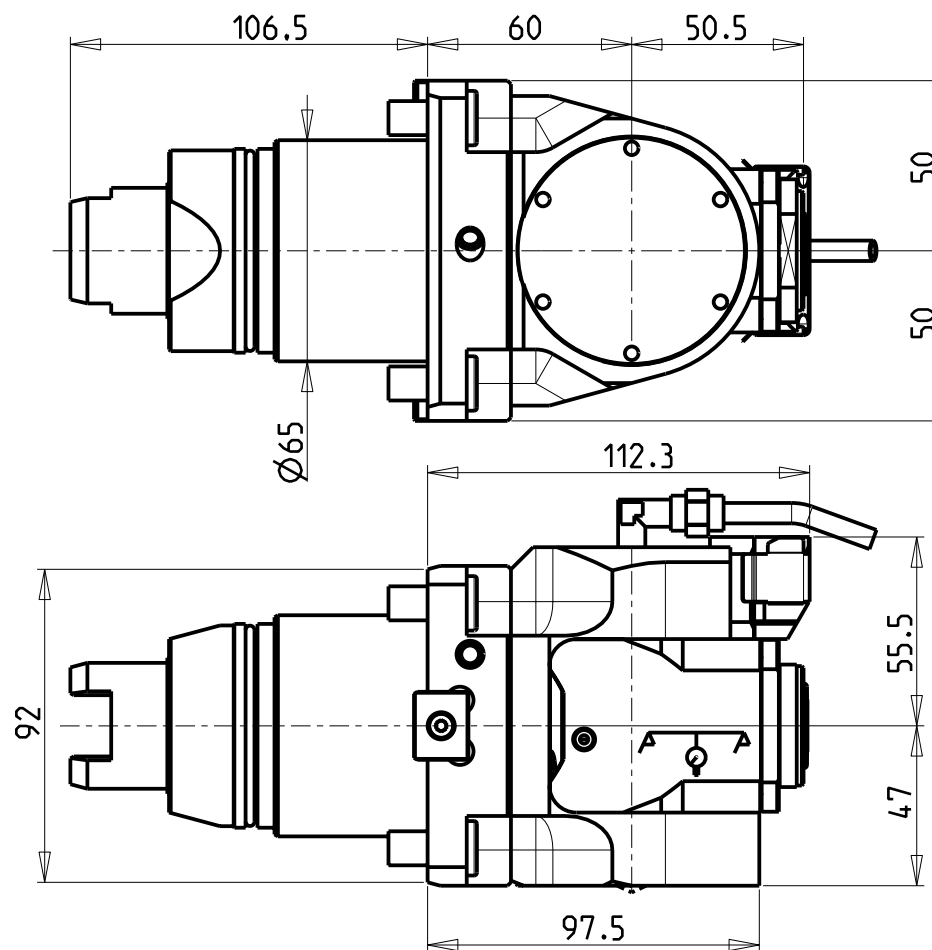
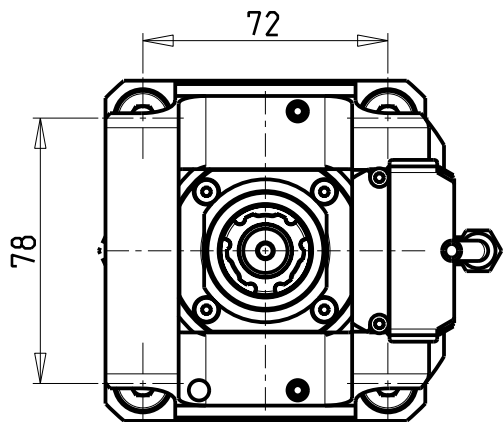

ATTENZIONE - ATTENTION - ACHTUNG

- Per lo smontaggio degli utensili utilizzare sempre la chiave di contrasto come indicato nel manuale d'uso.
- For disassembly of the tools use always the contrast key as mentioned in the user instructions.
- Fuer das Abmontieren der Werkzeuge immer den Gegenschlüssel benutzen wie in der Bedienungsanleitung erwäohnt.

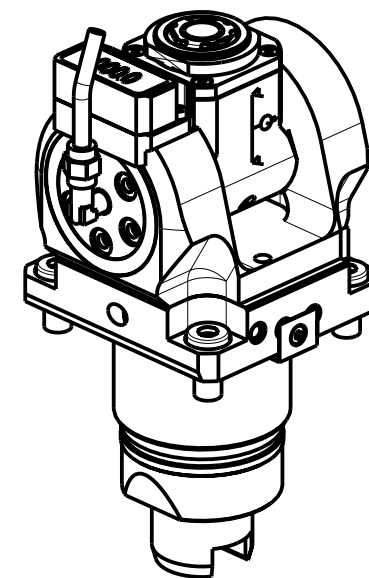

Cod. MT	Mandrino Spindle Spindel	I	RPM	Coppia Max Max Torque Max Drehmoment	Lubrificazione int. Coolant through Innenkuehlung	Lubrificazione est. Ext. coolant Aussenkuehlung	CHIAVI INCLUSE Keys included Schluesssel inbegriffen			
							CHUB22	CHUB36	CHTAER20ZC	CHESLO7
TSM0105120	ERA20	1:1	5000	30Nm	-	X	CHUB22	CHUB36	CHTAER20ZC	CHESLO7
TSM0105220	ERA20	1:1	5000	30Nm	P=70bar	X	CHUB22	CHUB36	CHTAER20ZC	CHESLO7

TSUGAMI
MOD: M06 - M08

MODULO MOTORIZZATO ORIENTABILE +/-90° CON NONIO DIGITALE
+/-90° adjustable angle driven tool with digital display
Angetriebenes Werkzeug schwenkbar +/-90° mit digital display

Subject to change without notice.

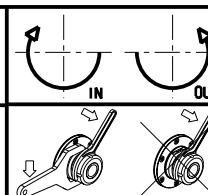

M.T. srl
Via Casino Albini 480
Tel. 0541/956034-957884
Fax 0541/956341
47842 S. GIOVANNI IN M. (RN)
e-mail: mtma@mtmarchetti.com
http://www.mtmarchetti.com



PAGINA TSM335-3-01

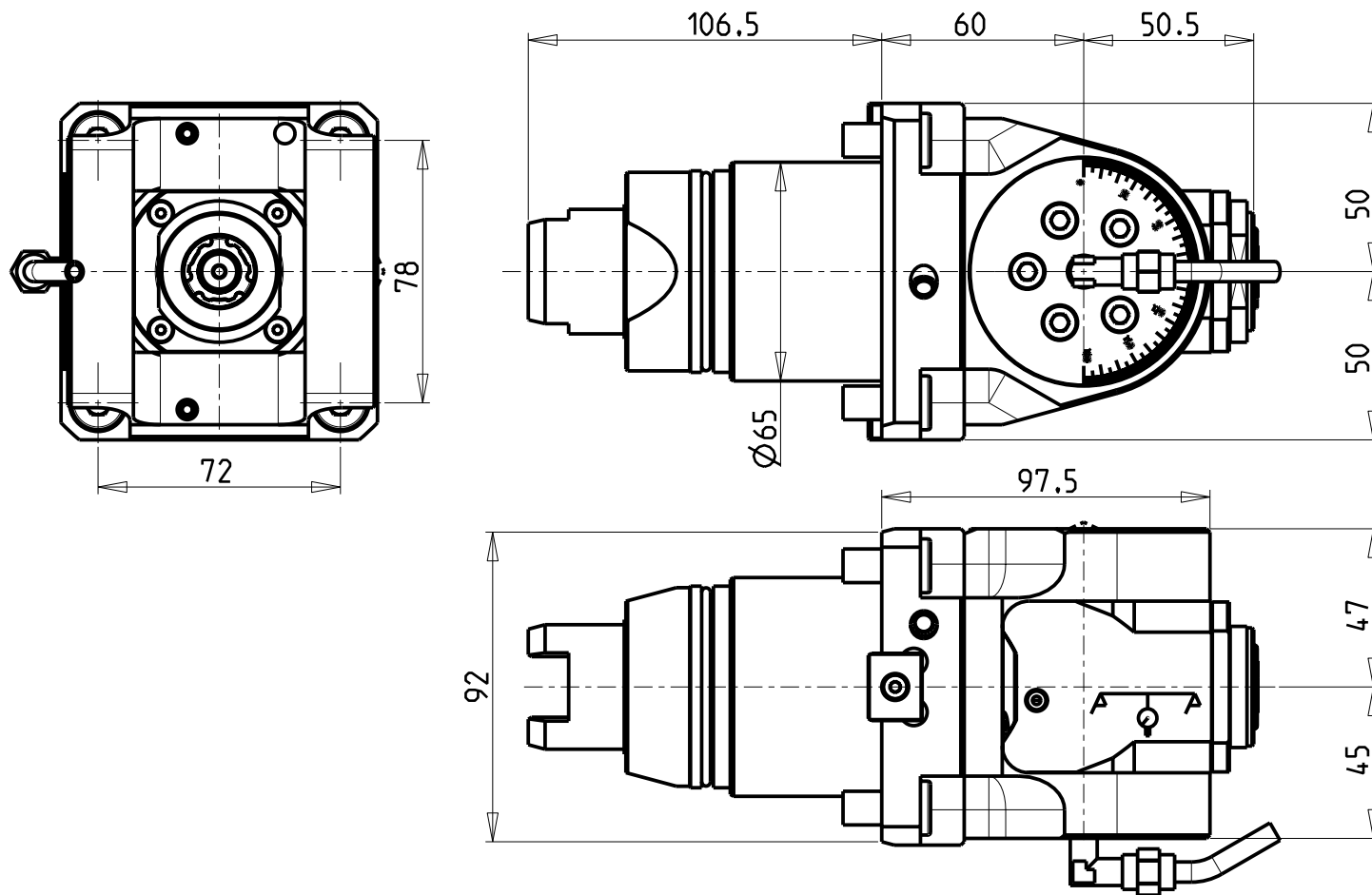

ATTENZIONE - ATTENTION - ACHTUNG

- Per lo smontaggio degli utensili utilizzare sempre la chiave di contrasto come indicato nel manuale d'uso.
- For disassembly of the tools use always the contrast key as mentioned in the user instructions.
- Fuer das Abmontieren der Werkzeuge immer den Gegenschlüssel benutzen wie in der Bedienungsanleitung erwäehnt.

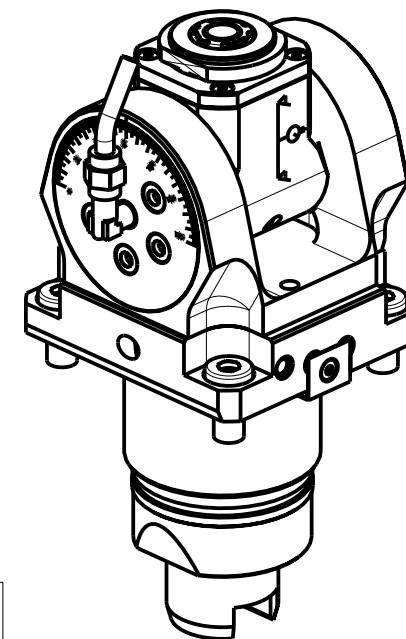

Cod. MT	Mandrino Spindle Spindel	I	RPM	Coppia Max Max Torque Max Drehmoment	Lubrificazione int. Coolant through Innenkuehlung	Lubrificazione est. Ext. coolant Aussenkuehlung	CHIAVI INCLUSE Keys included Schlüssel inbegriffen			
TSM0100316	ERA16	1:2	10000	8Nm	-	X	CHUB19_SP3	CHUB32	CHTAER16ZC	CHESL07
TSM0100416	ERA16	1:2	10000	8Nm	P=70bar	X	CHUB19_SP3	CHUB32	CHTAER16ZC	CHESL07

TSUGAMI

MOD: M06 - M08

MODULO MOTORIZZATO ORIENTABILE +/-90° MOLTIPLICATO I=1:2

+/-90° adjustable angle driven tool geared-up I=1:2

Angetriebenes Werkzeug schwenkbar +/-90° uebersetzt I=1:2

Subject to change without notice.

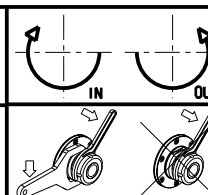

M.T. srl

Via Casino Albini 480
Tel. 0541/956034-957884
Fax 0541/956341
47842 S. GIOVANNI IN M. (RN)
e-mail: mtma@mtmarchetti.com
http://www.mtmarchetti.com



PAGINA TSM336-3-00

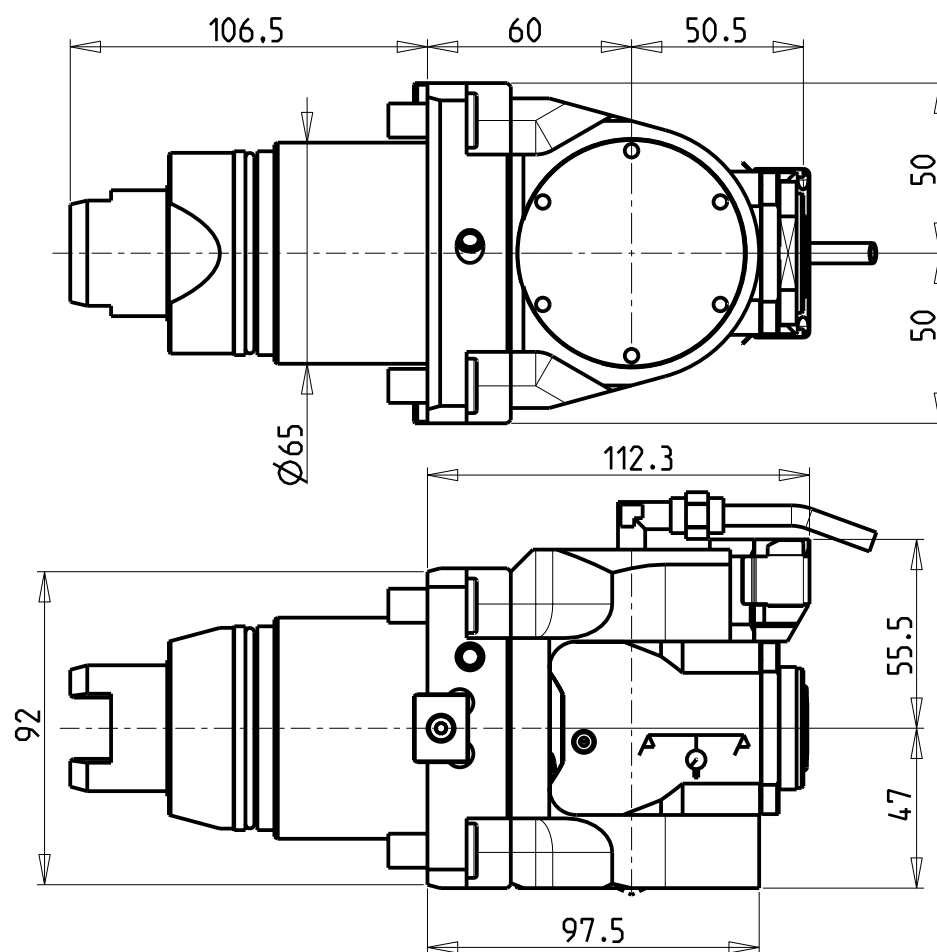
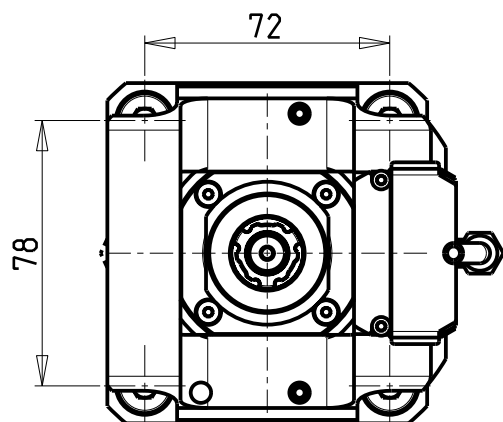

ATTENZIONE - ATTENTION - ACHTUNG

- Per lo smontaggio degli utensili utilizzare sempre la chiave di contrasto come indicato nel manuale d'uso.
- For disassembly of the tools use always the contrast key as mentioned in the user instructions.
- Fuer das Abmontieren der Werkzeuge immer den Gegenschlüssel benutzen wie in der Bedienungsanleitung erwäehnt.

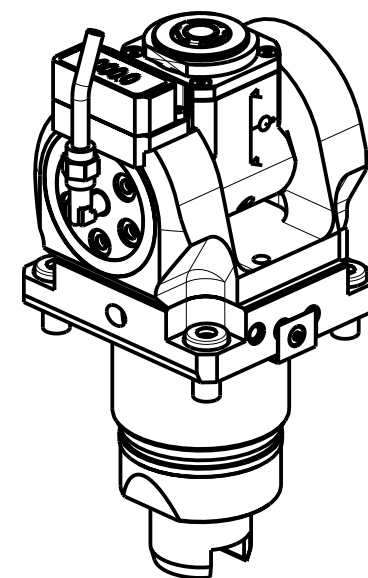

Cod. MT	Mandrino Spindle Spindel	I	RPM	Coppia Max Max Torque Max Drehmoment	Lubrificazione int. Coolant through Innenkuehlung	Lubrificazione est. Ext. coolant Aussenkuehlung	CHIAVI INCLUSE Keys included Schlüssel inbegriffen			
TSM0105316	ERA16	1:2	10000	8Nm	-	X	CHUB19_SP3	CHUB32	CHTAER16ZC	CHESL07
TSM0105416	ERA16	1:2	10000	8Nm	P=70bar	X	CHUB19_SP3	CHUB32	CHTAER16ZC	CHESL07

TSUGAMI
MOD: M06 - M08

MODULO MOTORIZZATO ORIENTABILE +/-90° MOLTIPLICATO I=1:2 CON NONIO DIGITALE
+/-90° adjustable angle driven tool geared-up I=1:2 with digital display
Angetriebenes Werkzeug schwenkbar +/-90° uebersetzt I=1:2 mit digital display

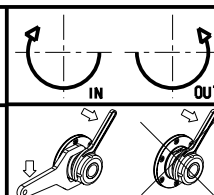

M.T. srl
Via Casino Albini 480
Tel. 0541/956034-957884
Fax 0541/956341
47842 S. GIOVANNI IN M. (RN)
e-mail: mtma@mtmarchetti.com
http://www.mtmarchetti.com



PAGINA TSM336-3-01

Subject to change without notice.

10/2021

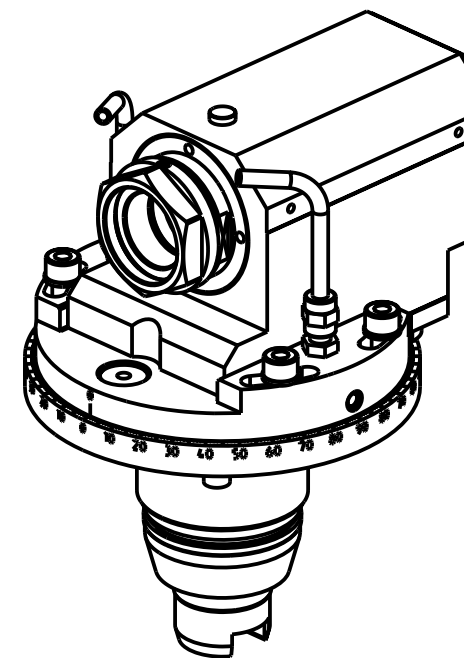
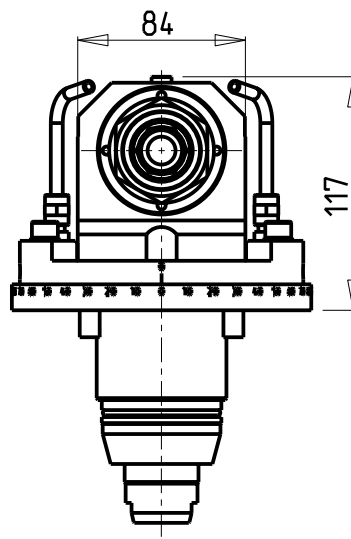
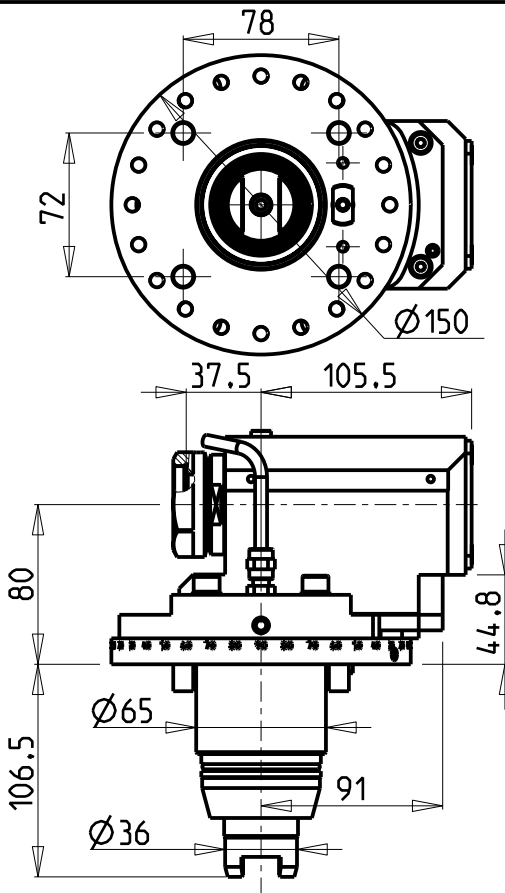

ATTENZIONE - ATTENTION - ACHTUNG

- VERIFICARE LE MISURE DI INGOMBRO PER POSSIBILE INTERFERENZA SU ALCUNI MODELLI DI MACCHINE
- Please check the overall sizes for possible interferences on some machine models
- Bitte überprüfen sie das ausmass um mögliche interferenzen auf einigen maschinen modellen zu vermeiden

PER PORTAUTENSILI MODULARI MTSK-40 VEDI PAG. TBL300-1-40
 FOR MTSK-40 QUIK CHANGE TOOLHOLDERS CLAMPINGS SEE PAGE TBL300-1-40
 FUER MTSK-40 MODULARE WERKZEUGAUFNAHMEN SIEHE SEITE TBL300-1-40

Cod. MT	Mandrino Spindle Spindel	I	RPM	Coppia Max Max Torque Max Drehmoment	Lubr.esterna Ext. coolant Aussenkuehlung	CHIAVI INCLUDE Keys included Schluessel einbegriffen
TSM0200100	MTSK-40	1:1	5000	50Nm	X	n°2 CHUB46

TSUGAMI
 MOD: M06 - M08

MODULO MOTORIZZATO ASSIALE MTSK PER POWER SKIVING H=80mm
 Axial MTSK driven tool for Power Skiving H=80mm
 Axial MTSK angetriebenes Werkzeug fuer Power Skiving H=80mm

Subject to change without notice.

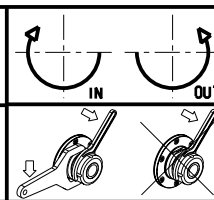

M.T. srl
 Via Casino Albini 480
 Tel. 0541/956034-957884
 Fax 0541/956341
 47842 S. GIOVANNI IN M. (RN)
 e-mail: mtma@tmarchetti.com
 http://www.tmmarchetti.com



PAGINA TSM350-3-00-K

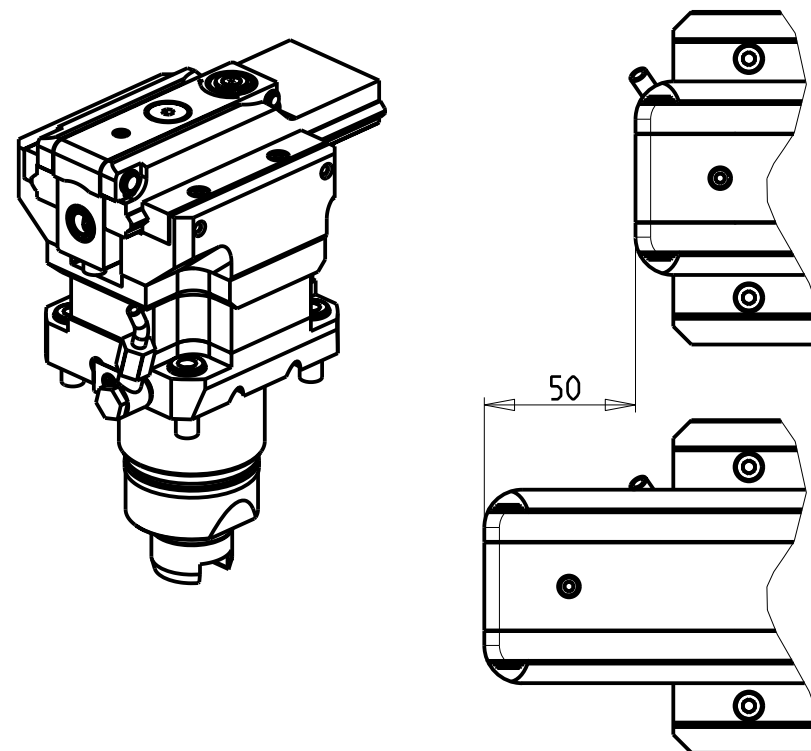
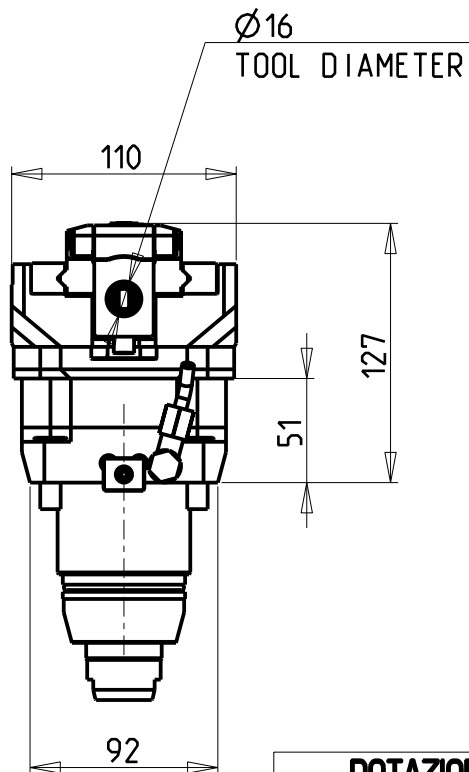
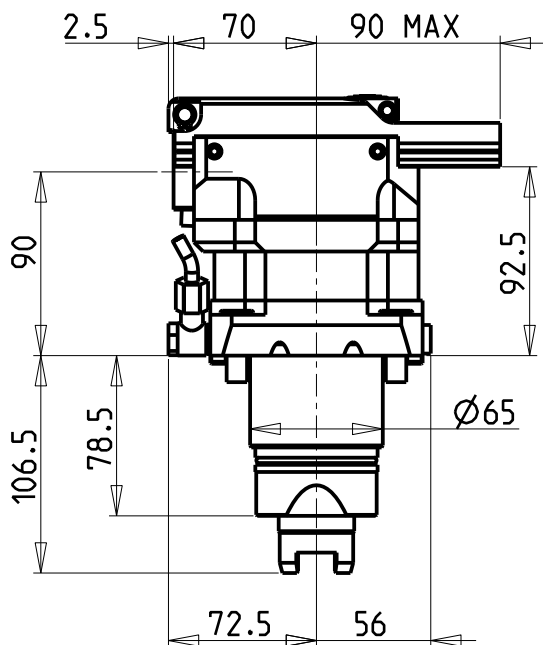
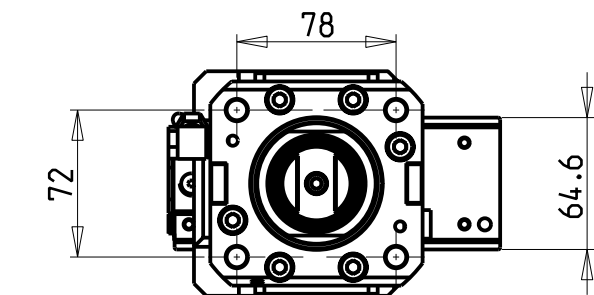

DOTAZIONI - SUPPLIED WITH - AUSSTATTUNG

N°1 Boccia di riduz. Ø16-Ø12 e N°1 Boccia di riduz. Ø16-Ø10
 N°1 Reduction bush Ø16-Ø12 and N°1 Reduction bush Ø16-Ø10
 N°1 Reduzierbuchsen Ø16-Ø12 und N°1 Reduzierbuchsen Ø16-Ø10

PER UTENSILI STOZZATORI VEDI PAG. TBL400-1-00
 FOR DRIVEN SLOTTING TOOL CUTTING-TOOLS SEE PAGE TBL400-1-00
 FÜR NUTENSTOSS-WERKZEUG SCHNEIDWERKZEUGE SIEHE SEITE TBL400-1-00

Cod. MT	I	RPM MAX	Reversibile lato mandrino/contromandrino Reversible sub/main spindle side Umkehrbare Spindel-seite/ Gegenspindel-seite	Lubr. esterna Ext. coolant Aussenkuehlung
TSM0210100	4:1	2000	X	X

TSUGAMI
 MOD: M06 - M08

MODULO MOTORIZZATO STOZZATORE CORSA 50mm H=90mm
 Slotting driven tool 50mm stroke H=90mm
 Keilnutenstossmaschine 50mm Hub H=90mm

Subject to change without notice.

M.T. srl
 Via Casino Albini 480
 Tel. 0541/956034-957884
 Fax 0541/956341
 47842 S. GIOVANNI IN M. (RN)
 e-mail: mtma@mtmarchetti.com
 http://www.mtmarchetti.com



PAGINA TSM360-3-00

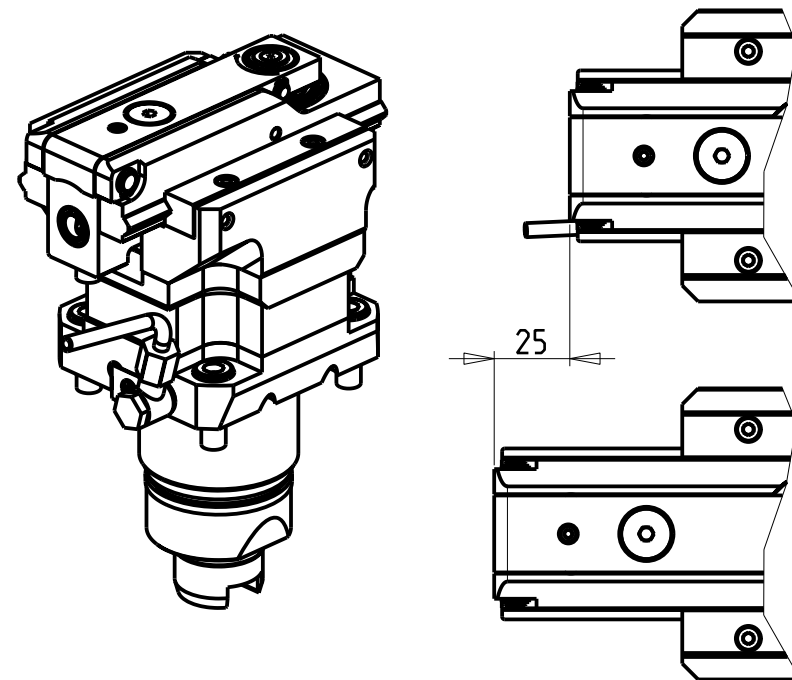
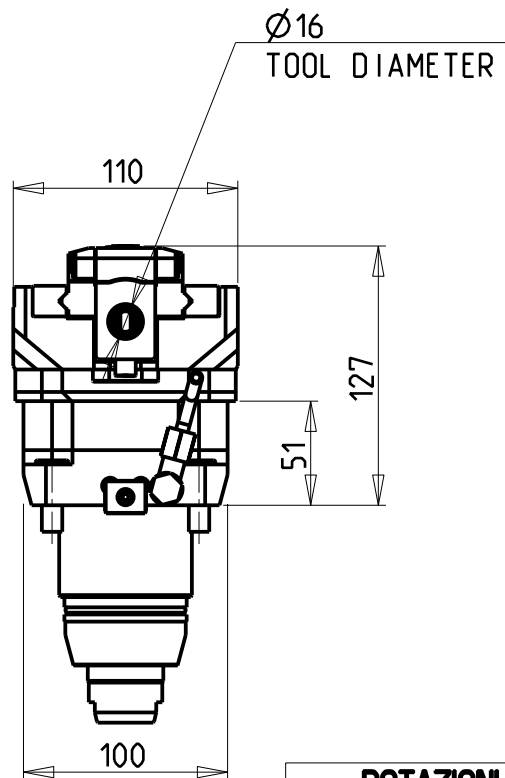
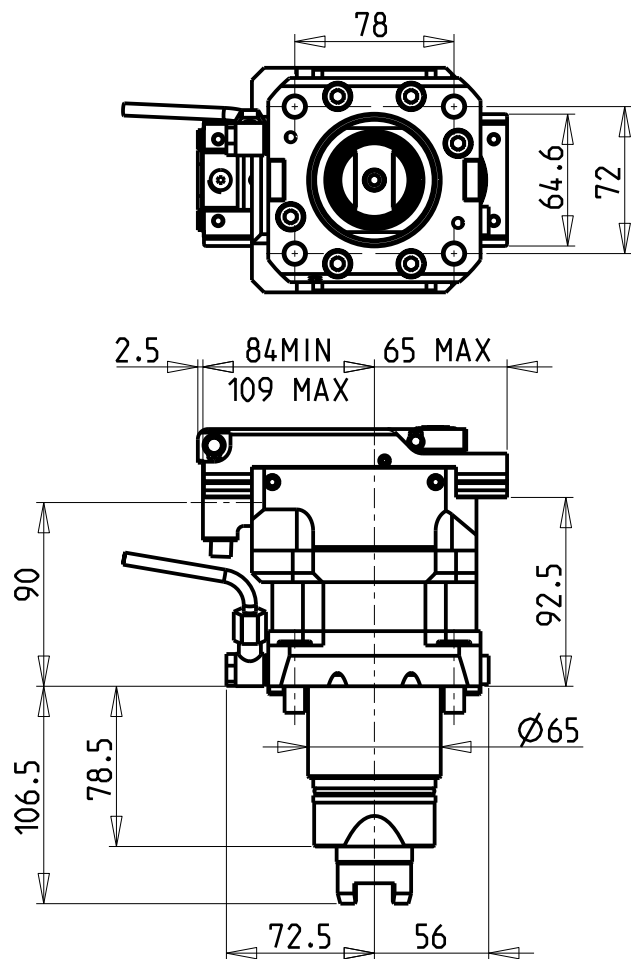

DOTAZIONI - SUPPLIED WITH - AUSSTATTUNG

N°1 Boccola di riduz. $\varnothing 16$ - $\varnothing 12$ e N°1 Boccola di riduz. $\varnothing 16$ - $\varnothing 10$
 N°1 Reduction bush $\varnothing 16$ - $\varnothing 12$ and N°1 Reduction bush $\varnothing 16$ - $\varnothing 10$
 N°1 Reduzierbuchsen $\varnothing 16$ - $\varnothing 12$ und N°1 Reduzierbuchsen $\varnothing 16$ - $\varnothing 10$

PER UTENSILI STOZZATORI VEDI PAG. TBL400-1-00
 FOR DRIVEN SLOTTING TOOL CUTTING-TOOLS SEE PAGE TBL400-1-00
 FÜR NUTENSTOSS-WERKZEUG SCHNEIDWERKZEUGE SIEHE SEITE TBL400-1-00

Cod. MT	I	RPM MAX	Reversibile lato mandrino/contromandrino Reversible sub/main spindle side Umkehrbare Spindel-seite/ Gegenspindel-seite	Lubr. esterna Ext. coolant Aussenkuehlung
TSM0210200	4:1	2400	X	X

TSUGAMI

MOD: M06 - M08

MODULO MOTORIZZATO STOZZATORE CORSA 25mm H=90mm

Slotting driven tool 25mm stroke H=90mm

Keilnutenstossmaschine 25mm Hub H=90mm

Subject to change without notice.

M.T. srl

Via Casino Albini 480
 Tel. 0541/956034-957884
 Fax 0541/956341

47842 S. GIOVANNI IN M. (RN)
 e-mail: mtma@mtmarchetti.com
 http://www.mtmarchetti.com



PAGINA TSM360-3-01

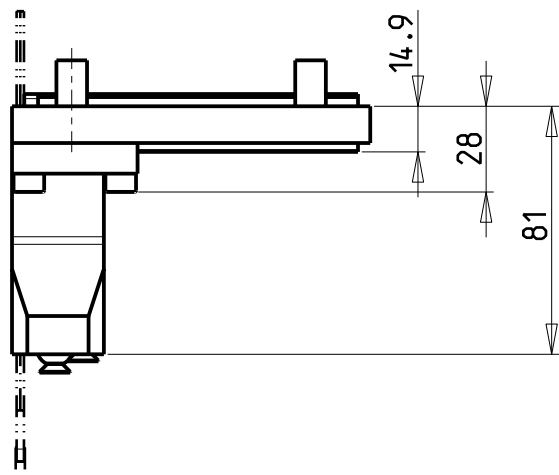
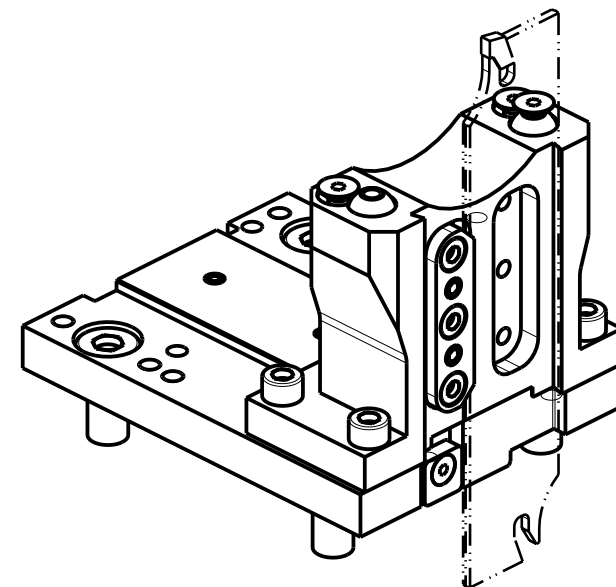
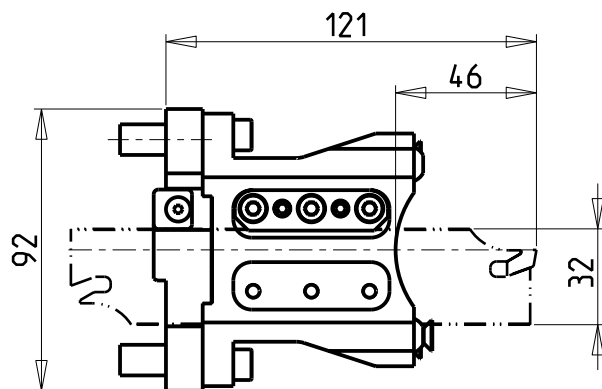
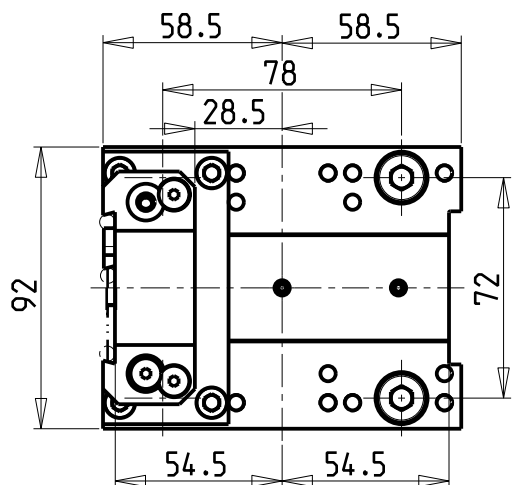

POSSIBILITA' DI LAVORO M3/M4
 OPTION OF M3/M4 WORKING
 ARBEITSMÖGLICHKEIT M3/M4

DOTAZIONI - SUPPLIED WITH - AUSSTATTUNG

- N°1 - LAMA - BLADE - KLINGE ISCAR H=32 Sp. 3/4mm (KENNAMETAL OPTIONAL)
- N°10 - INSERTI - INSERTS - EINLAGEN
- N°1 - CHIAVE A T PER MONTAGGIO INSERTI
 - T-WRENCH FOR INSERT SET UP
 - T-SCHLUESSEL FUER EINSATZSTUECK-MONTAGE

Cod. MT	N°Utensili N°Tools N°Werkzeuge	Reversibile lato mandrino/contromandrino Reversible sub/main spindle side Umkehrbare Spindel-seite/ Gegenspindel-seite	Lubr.esterna Ext. coolant Aussehenkuehlung
TSM0090132	1	X	X

TSUGAMI

MOD: M06 - M08

PORTAUTENSILE RADIALE PER LAMA

Radial blade holder

Radial Abstechhalter

Subject to change without notice.

M.T. srl

Via Casino Albini 480
 Tel. 0541/956034-957884
 Fax 0541/956341
 47842 S. GIOVANNI IN M. (RN)
 e-mail: mtma@mtmarchetti.com
 http://www.mtmarchetti.com



PAGINA TSM520-3-01

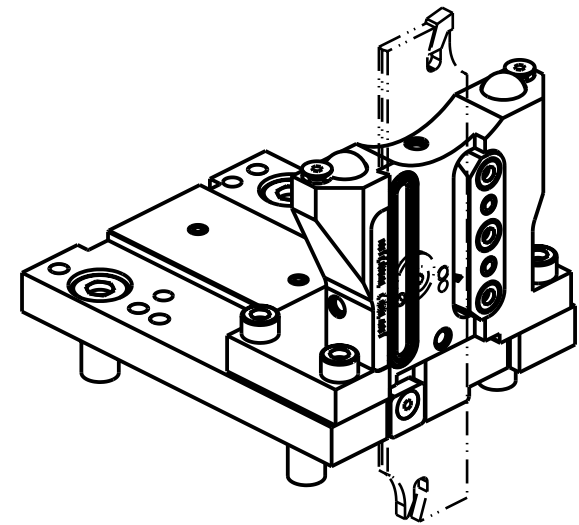
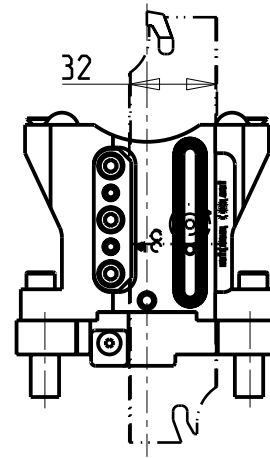
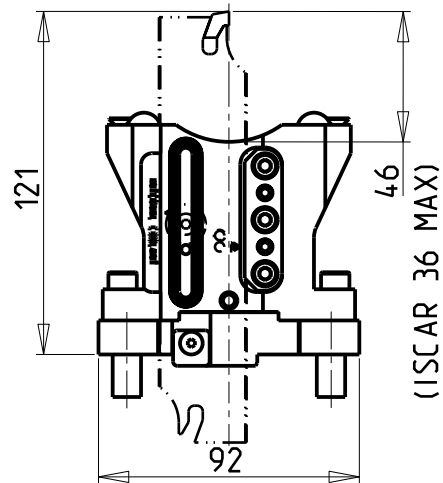
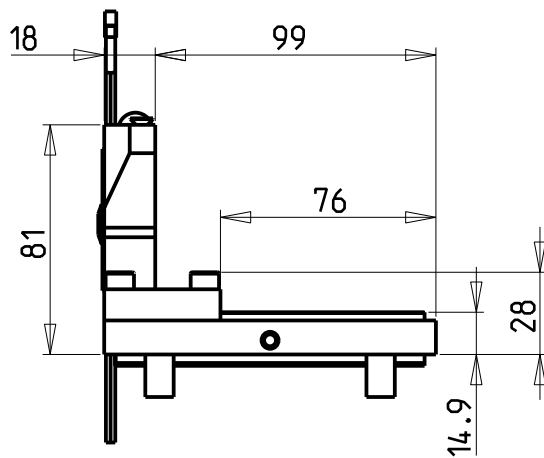

versione dx
right version
version rechts

versione sx
left version
version links

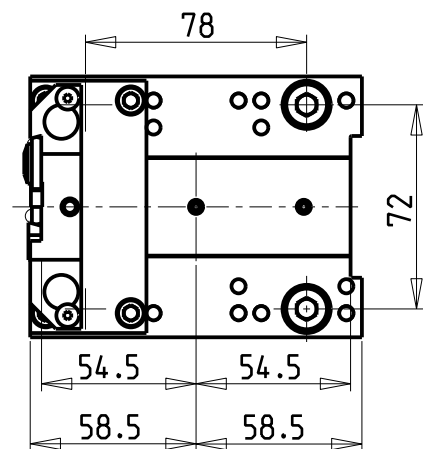

**KIT LAME NON INCLUSI (OPZIONALI)
BLADES NOT SUPPLIED WITH (OPTIONAL)
KLINGEN NICHT INBEGRIFFEN (OPTIONAL)**

- LAMA-BLADE-KLINGE SANDVIK H=32 sp.3 cod. QD_NN2G60C25A
+INSERTI-INSERTS-EINLAGEN cod. QD_NG_0300_0002_CM_1145 (10 pz.)
- LAMA-BLADE-KLINGE SANDVIK H=32 sp.4 cod. QD_NN2H60C25A
+INSERTI-INSERTS-EINLAGEN cod. QD_NH_0400_0002_CM_1145 (10 pz.)
- LAMA-BLADE-KLINGE ISCAR H=32 sp.3 cod. SGFH_32K_3
+INSERTI-INSERTS-EINLAGEN cod. 6011365 (10pz.)
- LAMA-BLADE-KLINGE ISCAR H=32 sp.4 cod. SGFH_32K_4
+INSERTI-INSERTS-EINLAGEN cod. 6011366 (10pz.)
- LAMA-BLADE-KLINGE WALTER H=32 sp.3 cod. G2042.32N-3T45SX-P
+INSERTI-INSERTS-EINLAGEN cod. SX-3E300N02-CE4 WSM33S (10pz.) + CHIAVE-KEY cod. FS1494
- LAMA-BLADE-KLINGE WALTER H=32 sp.4 cod. G2042.32N-4T50SX-P
+INSERTI-INSERTS-EINLAGEN cod. SX-4E400N02-CE4 WSM33S (10pz.) + CHIAVE-KEY cod. FS1494

Cod. MT		N°Utensili N°Tools N°Werkzeuge	Reversibile lato mandrino/contromandrino Reversible sub/main spindle side Umkehrbare Spindelseite/ Gegenspindel-seite	Lubr.esterna Ext. coolant Aussenkuehlung	Lubr.interna Coolant through Innenkuehlung
versione dx right version version rechts	versione sx left version version links				
TSM0130132R	TSM0130132L	1	X	X	P=70bar

TSUGAMI
MOD: M06 - M08

PORTAUTENSILE RADIALE PER LAMA CON LUBRIFICAZIONE INTERNA
Radial blade holder with internal coolant
Radial Abstechhalter mit Innenkuehlung

Subject to change without notice.

M.T. srl
Via Casino Albini 480
Tel. 0541/956034-957884
Fax 0541/956341
47842 S. GIOVANNI IN M. (RN)
e-mail: mtma@mtmarchetti.com
http://www.mtmarchetti.com



PAGINA TSM520-3-05

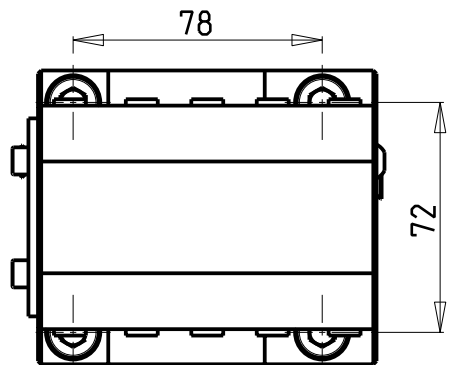
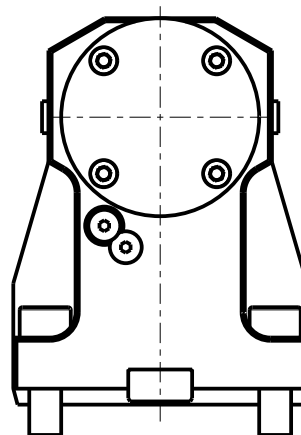
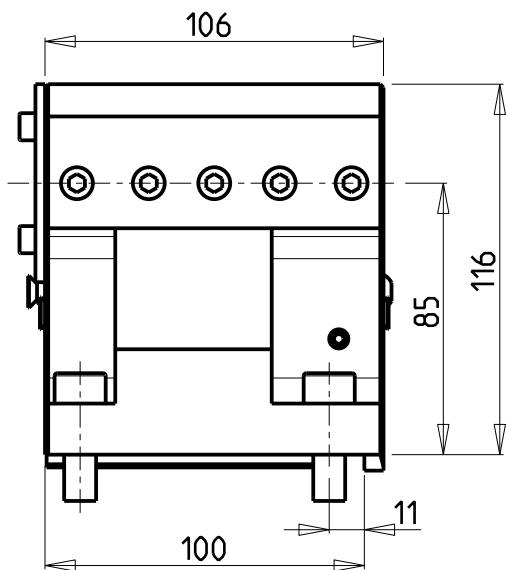
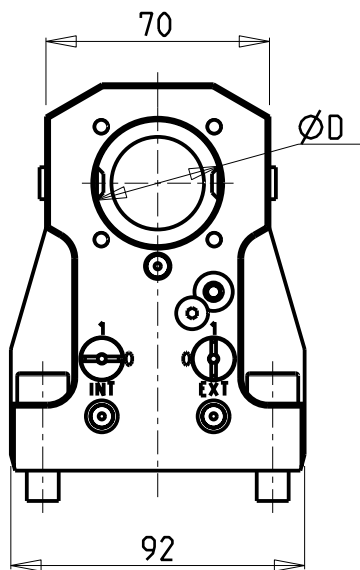

KIT ADDUZIONE INTERNA (OPZIONALE)
 KIT FOR INTERNAL COOLANT (OPTIONAL)
 KIT FUER INTERNE KUEHLMITTELZUFUHR (OPTIONAL)
 Ø40 cod. KIT1000003

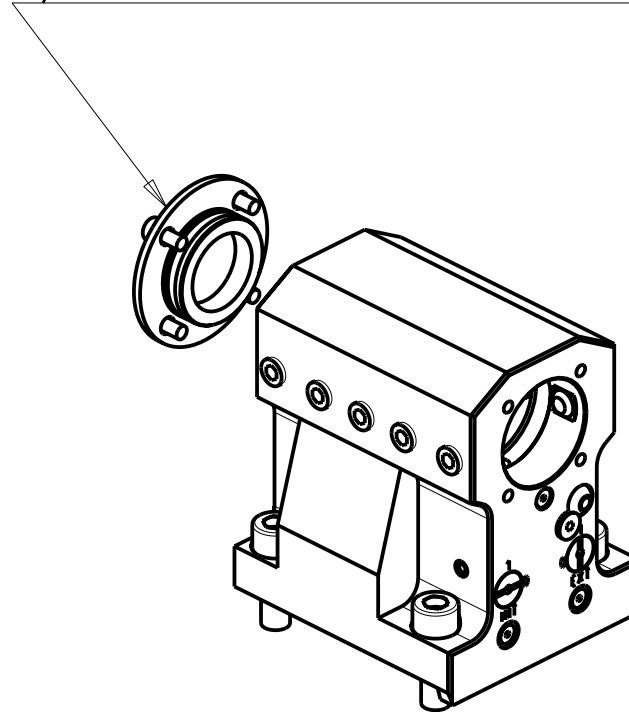

PER BOCCOLE DI RIDUZIONE VEDI PAG. TBL150-1-00
 FOR REDUCING BUSHINGS SEE PAGE TBL150-1-00
 FÜR REDUZIERBUCHSE SIEHE SEITE TBL150-1-00

Cod. MT	N°Utensili N°Tools N°Werkzeuge	Reversibile lato mandrino/contromandrino Reversible sub/main spindle side Umkehrbare Spindel-seite/ Gegenspindel-seite	Lubrificazione int. opzionale Coolant through optional Innenkuehlung Optional	Lubrificazione est. Ext. coolant Aussenkuehlung	Misure Dimensions Masse	Ø
TSM0164000	1	X	X	X	mm	40

TSUGAMI
 MOD: M06 - M08

PORTAUTENSILE ASSIALE PER BARENO Ø40mm H=85mm
 Axial single boring bar holder Ø40mm H=85mm
 Axial Bohrhälter Ø40mm H=85mm

Subject to change without notice.

M.T. srl
 Via Casino Albini 480
 Tel. 0541/956034-957884
 Fax 0541/956341
 47842 S. GIOVANNI IN M. (RN)
 e-mail: mtma@mtmarchetti.com
 http://www.mtmarchetti.com



PAGINA TSM630-3-10

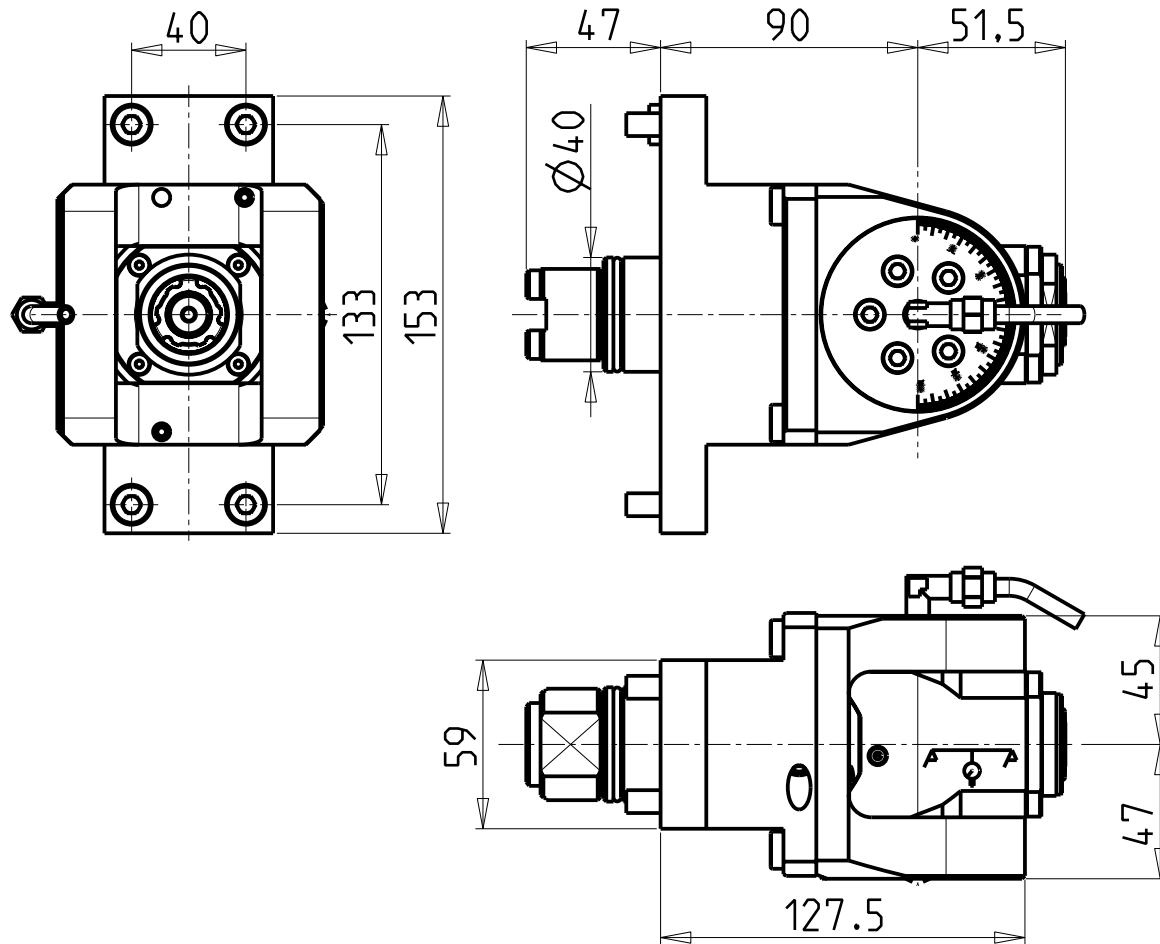

ATTENZIONE - ATTENTION - ACHTUNG

- Per lo smontaggio degli utensili utilizzare sempre la chiave di contrasto come indicato nel manuale d'uso.
- For disassembly of the tools use always the contrast key as mentioned in the user instructions.
- Fuer das Abmontieren der Werkzeuge immer den Gegenschlüssel benutzen wie in der Bedienungsanleitung erwäehnt.

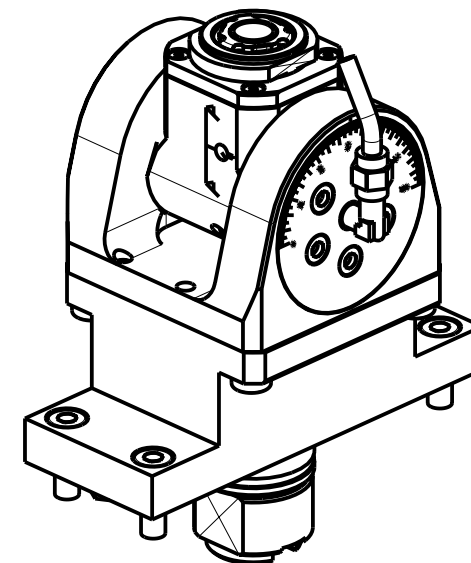

Cod. MT	Mandrino Spindle Spindel	I	RPM	Coppia Max Max Torque Max Drehmoment	Lubrificazione int. Coolant through Innenkuehlung	Lubrificazione est. Ext. coolant Aussenkuehlung	CHIAVI INCLUSE Keys included Schlüssel inbegriffen		
TSM0140120	ERA20	1:1	8000	30Nm	-	X	CHUB22	CHUB36	CHTAER20ZC
TSM0140220	ERA20	1:1	8000	30Nm	P=70bar	X	CHUB22	CHUB36	CHTAER20ZC

TSUGAMI
MOD: B038 - BH20/38

MODULO MOTORIZZATO ORIENTABILE +/-90°
+/-90° adjustable angle driven tool
Angetriebenes Werkzeug schwenkbar +/-90°

Subject to change without notice.

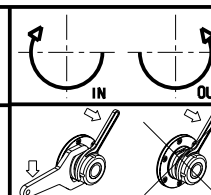

M.T. srl

Via Casino Albini 480
Tel. 0541/956034-957884
Fax 0541/956341
47842 S. GIOVANNI IN M. (RN)
e-mail: mtma@mtmarchetti.com
<http://www.mtmarchetti.com>



PAGINA TSM335-4-00

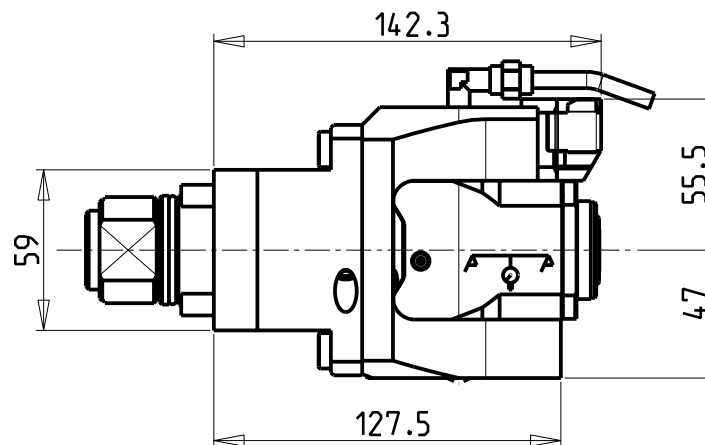
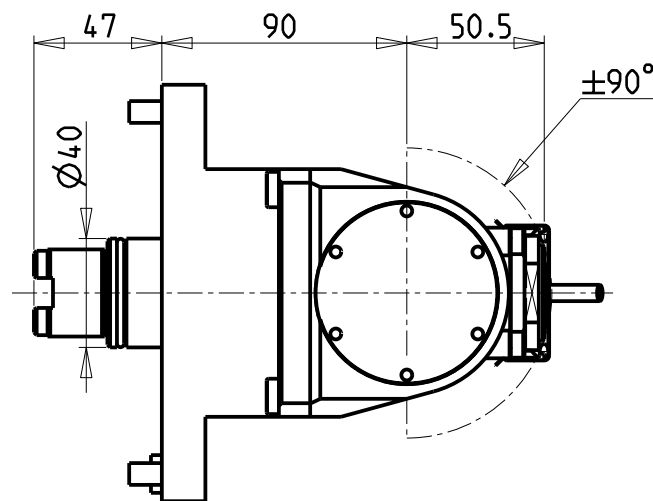
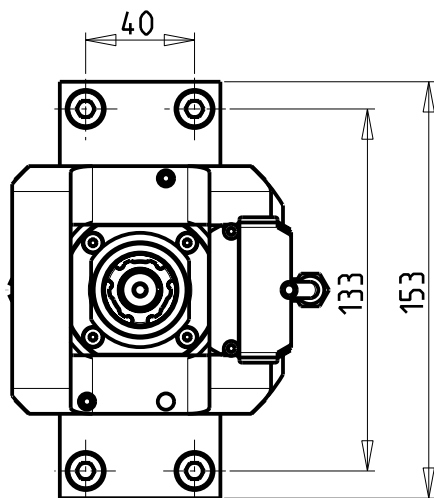

ATTENZIONE - ATTENTION - ACHTUNG

- Per lo smontaggio degli utensili utilizzare sempre la chiave di contrasto come indicato nel manuale d'uso.
- For disassembly of the tools use always the contrast key as mentioned in the user instructions.
- Fuer das Abmontieren der Werkzeuge immer den Gegenschlüssel benutzen wie in der Bedienungsanleitung erwäehnt.

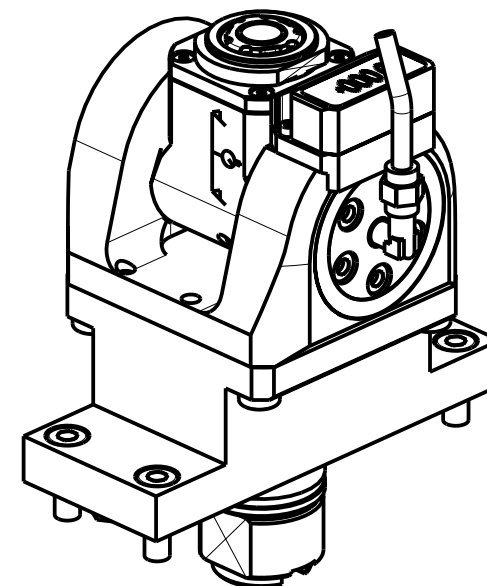

Cod. MT	Mandrino Spindle Spindel	I	RPM	Coppia Max Max Torque Max Drehmoment	Lubrificazione int. Coolant through Innenkuehlung	Lubrificazione est. Ext. coolant Aussenkuehlung	CHIAVI INCLUSE Keys included Schluessel inbegriffen		
							CHUB22	CHUB36	CHTAER20ZC
TSM0145120	ERA20	1:1	8000	30Nm	-	X	CHUB22	CHUB36	CHTAER20ZC
TSM0145220	ERA20	1:1	8000	30Nm	P=70bar	X	CHUB22	CHUB36	CHTAER20ZC

TSUGAMI
MOD: B038 - BH20/38

MODULO MOTORIZZATO ORIENTABILE $\pm 90^\circ$ CON NONIO DIGITALE
 $\pm 90^\circ$ adjustable angle driven tool with digital display
 Angetriebenes Werkzeug schwenkbar $\pm 90^\circ$ mit digital display

Subject to change without notice.

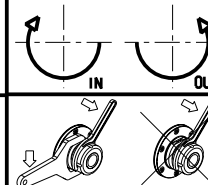

M.T. srl
 Via Casino Albini 480
 Tel. 0541/956034-957884
 Fax 0541/956341
 47842 S. GIOVANNI IN M. (RN)
 e-mail: mtma@mtmarchetti.com
 http://www.mtmarchetti.com



PAGINA TSM335-4-01

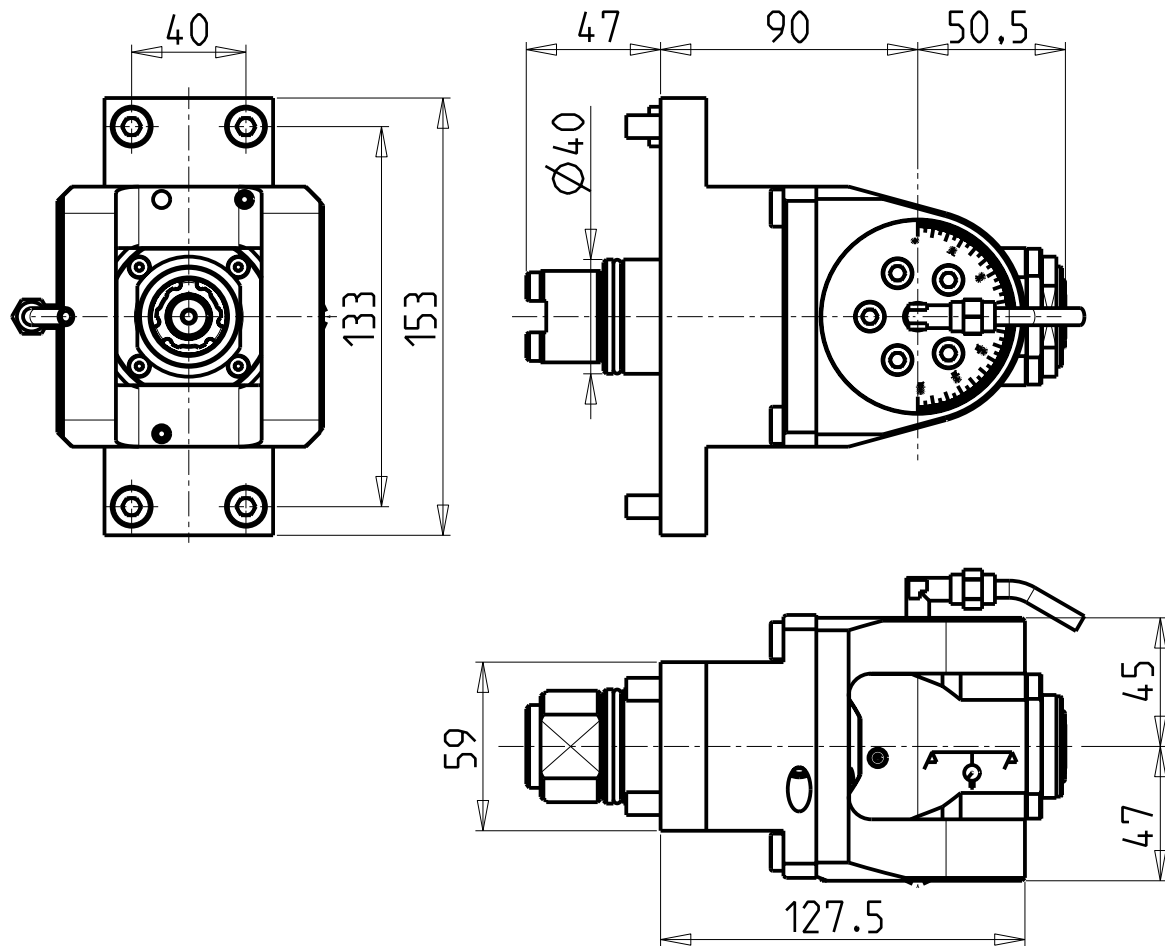

ATTENZIONE - ATTENTION - ACHTUNG

- Per lo smontaggio degli utensili utilizzare sempre la chiave di contrasto come indicato nel manuale d'uso.
- For disassembly of the tools use always the contrast key as mentioned in the user instructions.
- Fuer das Abmontieren der Werkzeuge immer den Gegenschlüssel benutzen wie in der Bedienungsanleitung erwähnt.

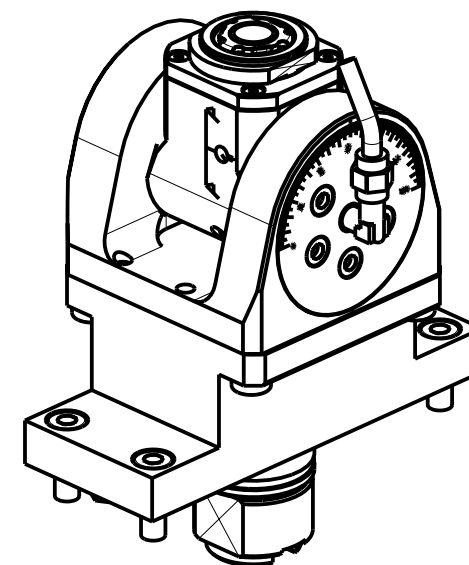

Cod. MT	Mandrino Spindle Spindel	i	RPM MAX	Coppia Max Max Torque Max Drehmoment	Lubrificazione int. Coolant through Innenkuehlung	Lubrificazione est. Ext. coolant Aussenkuehlung	CHIAVI INCLUSE Keys included Schluesssel inbegriffen		
TSM0140316	ERA16	1:2	12000	8Nm	-	X	CHUB19_SP3	CHUB32	CHTAER16ZC
TSM0140416	ERA16	1:2	12000	8Nm	P=70bar	X	CHUB19_SP3	CHUB32	CHTAER16ZC

TSUGAMI
MOD: B038 - BH20/38

MODULO MOTORIZZATO ORIENTABILE +/-90° MOLTIPLICATO I=1:2
+/-90° adjustable angle driven tool geared-up I=1:2
Angetriebenes Werkzeug schwenkbar +/-90° uebersetzt I=1:2

Subject to change without notice.

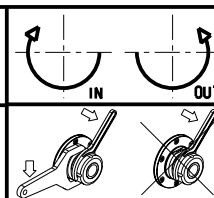

M.T. srl
Via Casino Albini 480
Tel. 0541/956034-957884
Fax 0541/956341
47842 S. GIOVANNI IN M. (RN)
e-mail: mtma@mtmarchetti.com
<http://www.mtmarchetti.com>



PAGINA TSM336-4-00

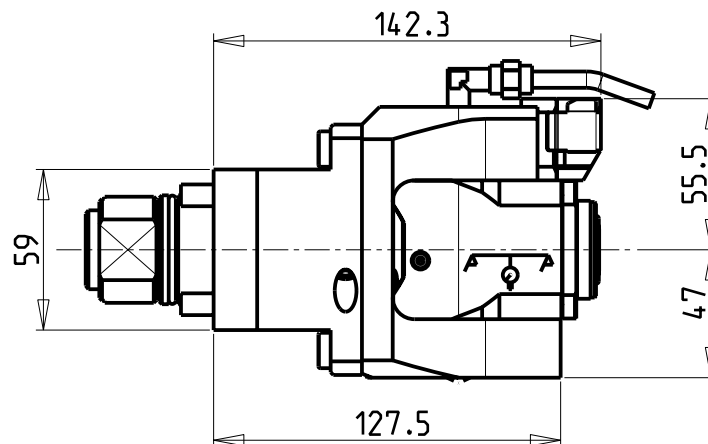
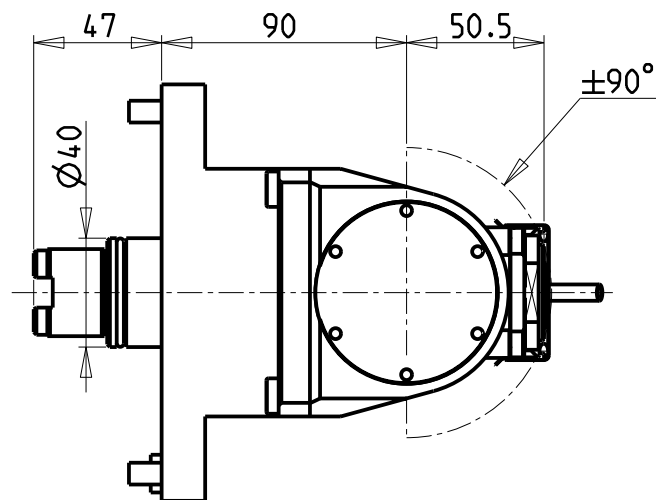
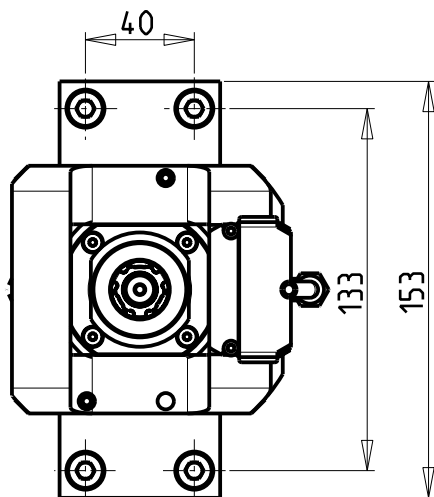

ATTENZIONE - ATTENTION - ACHTUNG

- Per lo smontaggio degli utensili utilizzare sempre la chiave di contrasto come indicato nel manuale d'uso.
- For disassembly of the tools use always the contrast key as mentioned in the user instructions.
- Fuer das Abmontieren der Werkzeuge immer den Gegenschlüssel benutzen wie in der Bedienungsanleitung erwäehnt.

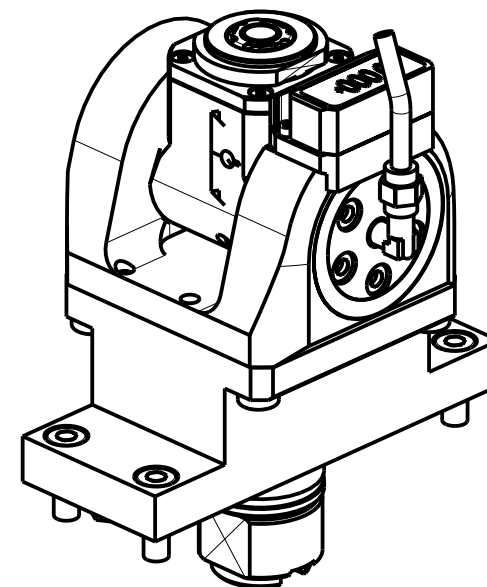

Cod. MT	Mandrino Spindle Spindel	i	RPM MAX	Coppia Max Max Torque Max Drehmoment	Lubrificazione int. Coolant through Innenkuehlung	Lubrificazione est. Ext. coolant Aussenkuehlung	CHIAVI INCLUDE Keys included Schluesssel inbegriffen		
TSM0145316	ERA16	1:2	12000	8Nm	-	X	CHUB19_SP3	CHUB32	CHTAER16ZC
TSM0145416	ERA16	1:2	12000	8Nm	P=70bar	X	CHUB19_SP3	CHUB32	CHTAER16ZC

TSUGAMI
MOD: B038 - BH20/38

MODULO MOTORIZZATO ORIENTABILE $\pm 90^\circ$ MOLTIPLICATO 1:1:2 CON NONIO DIGITALE
 $\pm 90^\circ$ adjustable angle driven tool geared-up 1:1:2 with digital display
 Angetriebenes Werkzeug schwenkbar $\pm 90^\circ$ uebersetzt 1:1:2 mit digital display

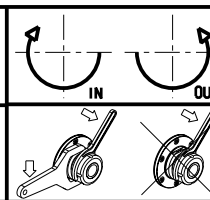

M.T. srl
 Via Casino Albini 480
 Tel. 0541/956034-957884
 Fax 0541/956341
 47842 S. GIOVANNI IN M. (RN)
 e-mail: mtma@mtmarchetti.com
 http://www.mtmarchetti.com



PAGINA TSM336-4-01

Subject to change without notice.

10/2021

